



HIGH-PERFORMANCE RECORDING VIDEO BORESCOPE SYSTEM

USER'S MANUAL



DCS1600

Please read this manual carefully and thoroughly before using this product.

TABLE OF CONTENTS

Introduction	3
Key Features	4
Safety Instructions.	4
What's in the Case.	4
Product Overview	5
Setup Instructions	6
Check Probe Connection.	6
Charge Battery	6
Insert SD Card	6
Operating Instructions.	7 – 11
Viewing Live Video on the Console.	7
Viewing Live Video on a TV Monitor	7 – 8
Taking Pictures and Recording Videos	8
Viewing Photos and Playing Back Videos	8
Accessing SD Card Content	8 – 9
Navigating the Main Menu	9 – 11
Attaching a Mirrored Viewing Tip (Optional).	11
Specifications	12
Operating, Maintenance & Troubleshooting Tips	13 – 14
Compatible Probes	14
Warranty Information.	15
Return for Repair Policy	15

INTRODUCTION

Thank you for purchasing General Tools & Instruments' (General's) DCS1600 High-Performance Recording Video Borescope System. Please read this user's manual carefully and thoroughly before using the instrument.

The DCS1600 is a complete system that combines an H16 Handheld Recording Video Borescope Console with a P16181SR-M flexible-obedient probe, which is 1m (39 in.) long and has a diameter of 5.5mm (0.22 in.). This user's manual refers to the H16, rather than to the DCS1600; both units are functionally identical. A list of all probes compatible with the H16 console can be found on p. 14.

The H16 has a 3.5-inch (diagonal) color LCD. A thumbwheel on the left side of the console allows you to adjust the brightness of the LEDs illuminating the camera at the end of the included probe or any compatible probe.

The console has three operating modes: Preview, Playback and Menu:

- **In Preview mode**, video framed by the camera's field of view is displayed in real time on the console's LCD. The H16 automatically enters this mode when powered on. A front-panel button allows you to enlarge (zoom in on) a target by 50% (a zoom level of 1.5X). The same button allows you to "mirror" video, making it possible to read serial numbers seen and "reversed" by an attached probe with a mirrored viewing tip. In Preview mode, real-time video also can be exported through an included video cable to any NTSC- or PAL-format TV with RCA input jacks. Operating in Preview mode, the H16 also allows you to record inspection videos (at 320 x 240 pixel resolution) and photos (at 640 x 480 pixel resolution) on an included SD memory card by pressing icon-labeled buttons on the console's front panel. The remaining front-panel buttons enable access to Playback and Menu modes.
- **In Playback mode**, you can browse the SD card for saved video and picture files and view the media on the console's LCD or a larger TV monitor. Video clips and photos also can be viewed on a PC in either of two ways: 1) by removing the SD card and plugging it into the computer directly or through a card reader; or 2) by using a supplied cable to connect the H16 to the PC through one of its USB ports. Because videos are saved as .asf files and photos as .jpg files, applications found on most PCs (Microsoft Windows Media Player and Microsoft Office Picture Manager) can open the files. The 2GB SD memory card included with the H16 can store at least 5 hours of video, recorded at an average of 6 Mbytes/minute, in addition to hundreds of photos.
- **In Menu mode**, you use familiar scrolling motions and responses to dialog boxes to navigate a main menu with six submenus. When selected, submenu items execute "housekeeping" functions such as deleting files, setting the date and time, enabling or disabling date and time stamps, choosing any of 14 languages for display indications, selecting a Video Out format and adjusting the console's Auto Power Off trigger. One of the submenus has a sub-submenu that allows you to adjust four attributes (brightness, contrast, hue and saturation) of video viewed on the console or an external monitor.

KEY FEATURES

- 3.5 in. diagonal color LCD for viewing probe video in real time and saved video and pictures later
- 1m (39 in.) long flexible-obedient probe with diameter of 5.5mm (0.22 in.)
- Compatible with dozens of high-performance camera-tipped probes from General (see p. 14)
- Thumbwheel for adjusting brightness of camera lighting
- Familiar menu-driven user interface for viewing and recording videos and photos on standard SD memory card (2GB card included) and playing back media on console, TV or PC
- Three mirrored probe tip accessories (for viewing at 70°, 90° and 110° off the probe axis)
- Rechargeable battery with 4-hour capacity
- 1-year limited warranty

SAFETY INSTRUCTIONS

CAUTION!

Never insert a probe attached to the H16 into a structure or space known or suspected to contain live electric wiring

- The H16 is intended for industrial applications only. Do not use it for human or any other biological inspections.
- Never insert an attached probe into any flammable gas or liquid (including fuels in an oil, gasoline or diesel tank)
- Do not disassemble the instrument. Doing so creates a potentially fatal electrical hazard (and voids the warranty as well).

WHAT'S IN THE CASE

The DCS1600 comes in a custom hard plastic protective carrying case. Inside the case are:

- The H16 console. The console integrates an LCD monitor, a connector for a high-performance camera-tipped probe from General, and front-panel controls for controlling the camera's lights, adjusting system parameters, and recording and playing back videos and photos captured by an attached probe.
- A 5.5mm diameter flexible-obedient probe of 1m length
- Attachable 70°, 90° and 110° mirrored probe tips
- A 2GB SD memory card
- An AC adapter/battery charger for a 110/220VAC supply. The adapter has a 5.5VDC, center-positive output plug.
- A video cable for connecting the H16 to a TV monitor. The cable has RCA plugs at one end and a mini-stereo plug at the other end.
- A USB cable with a mini-USB plug on one end and a full-size USB plug on the other end. It can be used to display the contents of the SD card on a computer directly, without removing the card from the console.
- A soft cloth, a bottle of liquid, and cotton swabs for cleaning the console
- A package of desiccant
- This user's manual

PRODUCT OVERVIEW

Fig. 1 shows the names and locations of all of the controls, ports and jacks of the H16. Table 1 details how the function of each front-panel button changes with the console's operating mode. Familiarize yourself with the labels, positions and functions of all controls and connectors before moving on to the Setup Instructions and Operating Instructions.

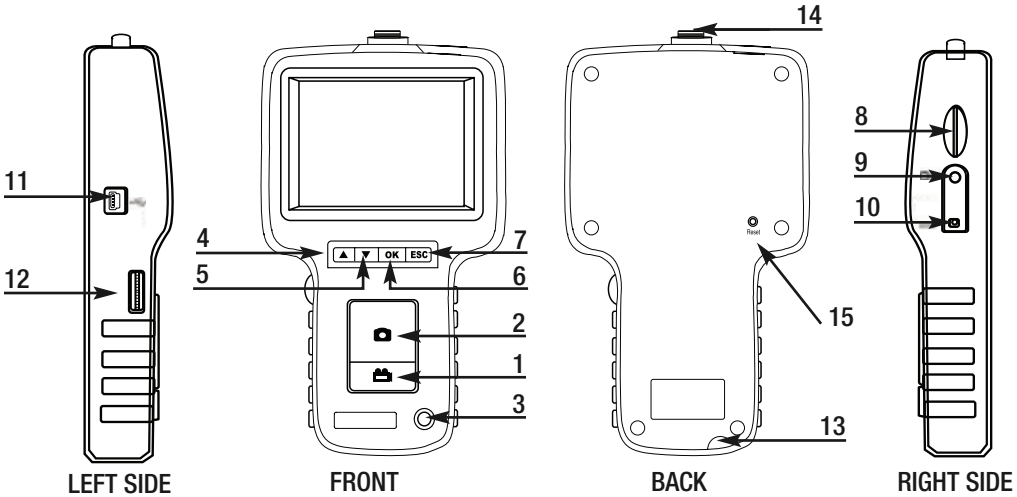

Fig. 1. The controls, ports and jacks of the H16

- | | |
|--|-------------------------------------|
| 1 Start/Stop Video Recording Button | 9 TV Out Jack |
| 2 Snapshot Button | 10 AC Adapter Jack |
| 3 Power On/Off Button | 11 Mini-USB Jack |
| 4 Previous Video/Photo Button | 12 Brightness Adjustment Thumbwheel |
| 5 Next Video/Photo Button | 13 Hanger Hole |
| 6 OK OK Button | 14 Probe Connector |
| 7 ESC Escape/Zoom/Mirror Button | 15 Reset Button |
| 8 SD Card Socket | |

Table 1. The H16's multi-function buttons

Button Label	In Preview Mode	In Playback Mode	In Menu Mode
	Switches to Playback mode	Selects next-oldest video or photo	Moves up one line
	Switches to Playback mode	Selects next-newest video or photo	Moves down one line
OK	Switches to Menu mode	Offers option to delete selected video or photo	Executes highlighted command
ESC	Pressed briefly , enlarges target by 50% (zooms 1.5X) Pressed and held , mirrors video	Switches to Preview mode	Switches to Preview mode
	Takes a picture (stores .jpg photo on SD card)	Recalls next photo or pauses/plays video clip	Displays repair data or opens submenu of video attribute options
	Starts/stops recording an .asf video on SD card	Switches to Preview mode	Switches to Preview mode

SETUP INSTRUCTIONS

CHECK PROBE CONNECTION

The H16 console and the P16181SR-M flexible-obedient probe ship already attached. To check the soundness of the connection, twist the console's probe connector (Fig. 1, Callout 14) clockwise with just enough force to confirm that it is still tightly coupled to the connector of the probe.

To detach the probe from the console, turn the collar on the probe connector counterclockwise and pull the probe straight out and away.

To reattach the probe (or attach any other compatible probe), plug its connector into the connector at the top of the console. The connectors mate in only one way, when the two red dots—one on the console's connector and the other under the collar at the end of the probe—are aligned. After you have lined up the dots, push the two connectors together so the alignment keys on opposite sides of the probe's connector slide over the flats of the console's connector. Slide the collar on the probe's connector forward and tighten the collar by turning it clockwise.

You can now peel away the plastic film that protects the console's LCD.

CHARGE BATTERY

To power on for the first time, plug one end of the supplied AC adapter/battery charger into a wall socket. Then swing the black rubber protective flap away from the right side of the H16 to expose the AC adapter jack (Fig. 1, Callout 10). Insert the cylindrical plug at the end of the adapter/charger cable into the AC adapter jack. This will begin charging the console's battery.

Push the **⏻** button and hold it for at least five seconds. The LCD will illuminate and briefly show the word **CAMERA** on the left and a battery icon on the right (both in green), superimposed on video being captured in real time by the camera at the end of the probe.

Use the thumbwheel on the left side of the console (Fig. 1, Callout 12) to adjust the intensity of the camera's lighting. In a brightly lit room, moving the thumbwheel has a big effect on the brightness of the LEDs at the tip of the probe, but a much smaller effect on the brightness of video on the screen. The on-screen impact of changing brightness is more pronounced in dark environments.

To turn off the H16, push the **⏻** button and hold it for at least five seconds.

It will take several hours to fully charge the H16's Lithium-ion battery the first time. **You cannot replace the battery**, which can only be replaced by General-authorized service personnel.

Do not open the case in an attempt to change the battery yourself. Doing so creates a potentially fatal electrical hazard (and voids the warranty as well) with the AC adapter plugged in.

With proper care (charging the battery often, and never allowing it to completely discharge), you can expect the H16's battery to last four or five years. A fully charged battery should power at least four hours of operation.

INSERT SD CARD

This step enables the H16 to store video clips and photos. Remove the supplied 2GB SD memory card from its packaging. Discard the packaging, but save the plastic storage case.

Push the SD card into the socket on the right side of the console (Fig. 1, Callout 8). Be sure the card's gold contacts are facing front and enter the socket first. Push in the card until you feel it spring back and you hear a click.

To remove the card later, push it in gently until you hear a click and the card pops out far enough for your fingers to grab.

OPERATING INSTRUCTIONS

VIEWING LIVE VIDEO ON THE CONSOLE

While the battery charges, General recommends becoming familiar with the H16's controls, indicators and menu options before taking the unit out into the field. The H16 operates the same way whether powered by its battery or the AC adapter.

To begin, power off the unit by pressing and holding the **⏻** button. Then press and hold the button again to power the console back on. Each time the console is powered on, the screen shown below will appear briefly. The text, bars and battery icon will appear in green, superimposed on live video captured by the camera probe. Together, the number of bars and the color of the icon represent the H16's two "vital signs"—battery charge and available memory capacity.

The number of filled-in bars at the bottom of the screen reflects the amount of data currently stored on the SD card. A full card would produce four green bars. The greener the  icon above the bars, the higher the current level of battery charge. A completely green icon would indicate a fully charged battery.

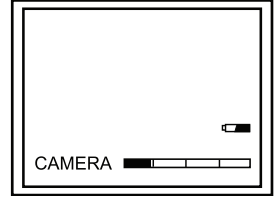

Next, get used to manipulating your probe. Typically, users insert a probe into an orifice (a hole in a wall or an engine's cylinder, for example) or into an inaccessible or hazardous area (the back or an equipment rack or an engine compartment, for example) to view components or environments that would otherwise be invisible. In practice, professionals usually insert flexible-obedient probes head-on into an orifice or area as a first step. They then pull the probe out and adjust its bend one or more times until the camera in the tip is pointing directly at the target or area of interest. With the probe inserted, you can twirl it until video appears right-side up, but in many cases you cannot change the probe's angle of approach very much.

You can, however, change the probe's viewing angle--by attaching one of the three included mirrored accessories to its tip. See p. 11 for attachment instructions.

Finally, note the dual function of the **ESC** button in Preview mode:

- **Press the ESC button briefly** and targets will be enlarged by 50% as the camera's field of view is reduced by that amount. A red plus sign (+) will appear on-screen and remain there after the available memory capacity bars and the battery charge icon make a brief appearance.
- **Press and hold the ESC button** and video will be mirrored horizontally, as shown in the two photos below. The effect makes it possible to read text or serial numbers "reversed" by an attached probe with a mirrored viewing tip—by undoing the reversal. A red "M" will appear on-screen to indicate that video is being mirrored.

You can mirror and zoom videos at the same time by pressing the **ESC** button briefly, and then pressing and holding the button.

VIEWING LIVE VIDEO ON A TV MONITOR

The DCS1600 system comes with a video cable for connecting the H16 console to a TV or TV monitor that uses either the NTSC or PAL analog broadcast standard. By making the connection, you can view live video (or saved videos and pictures) on a screen larger than the H16's.

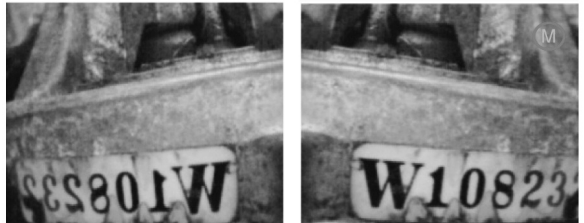

To implement the connection in hardware, insert the stereo mini-plug of the provided cable into the TV Out jack of the H16 (Fig. 1, Callout 9). Then insert the yellow RCA plug at the other end of the cable into the Video In jack of your TV or TV monitor, leaving the white RCA plug disconnected. Be sure to set the TV input to external video.







Real-time videos shown on an external monitor can be enlarged by pressing the **ESC** button. But videos cannot be mirrored, as they can when viewed on the H16's LCD.

To activate the connection in software and begin exporting H16 video to a TV, refer to the instructions for the **VIDEO FORMAT** and **AV OUTPUT** lines in the "Navigating the Main Menu" section of this manual, beginning on p. 9.

TAKING PICTURES AND RECORDING VIDEOS







To take a picture, make sure the H16 is in Preview mode (with live video appearing on the LCD) and press the  button. Doing so creates a .jpg file of the frame being displayed at that moment and stores it on the SD card. A red  icon briefly appears at the lower left of the LCD to confirm that a picture was taken. The H16 automatically returns to Preview mode after taking a picture.







To record a video, make sure the H16 is in Preview mode and press the  button. Doing so begins creating an.asf video file (with MPEG-4 compression) for storage on the SD card. A red  icon appears at the lower left of the screen to confirm that a recording is in progress, and it remains there for the duration of the video. To stop recording, press the  button again. This makes the red  icon disappear and returns the H16 to Preview mode.



While a video is being recorded, all console buttons other than the  and  buttons are disabled. Pressing the  button takes a picture, stops recording video and returns the H16 to Preview mode.

The H16 will be unable to store videos and pictures if its SD memory card is full, write-protected or damaged. When the instrument senses any of these conditions, it will superimpose the word **FULL** on the screen in Preview mode. To remedy the situation, either replace the full SD card by another card with spare capacity, or delete files individually or in bulk. Instructions for deleting files can be found later in this user's manual.

VIEWING PHOTOS AND PLAYING BACK VIDEOS

To view a picture or play back a video (or more than one picture or video) on the H16's LCD or a TV monitor, switch the unit out of Preview mode and into Playback mode by pressing the  or  button. In Playback mode, pressing the  button repeatedly recalls all photos and videos from memory in the reverse order in which they were created and stored (in other words, the newest first and the oldest last). Each press of the  button selects the next oldest picture or video. Videos begin playing automatically. A green  icon and a red  icon are superimposed on the video at the lower left of the screen. After a photo has been on-screen for 60 seconds, the H16 automatically switches to Preview mode.

Pressing the  button while a video is playing pauses playback and replaces the red  icon with a red  icon. Pressing the  button again resumes play and restores the red  icon. Pressing the  button while a video is playing switches to Preview mode. Pressing the  button while a picture is being displayed selects the next newest file.

While each photo and video is on-screen, pressing the **OK** button gives you the option to delete its file. Pressing the button calls up a dialog box with the word **DELETE** above the flashing word **NO**. Pressing the  or  button changes the flashing word to **YES**. When the correct answer (for you) appears, press the **OK** button to choose that action.

ACCESSING SD CARD CONTENT

Photos and videos stored on the SD card also can be viewed on a PC. If your computer has an SD card slot, you can remove the card from the H16 and plug it directly into a PC. If your PC does not have an SD card slot, you can purchase a USB SD card reader (Part No. SDRD1) from General.

If you choose to remove the SD card from the console and plug it into a PC, either directly or through a card reader, remember to eject the card from the PC once you are done viewing (and/or copying)

the files it contains. Depending on your PC's startup settings, your computer may fail to restart following its next shutdown if the SD card remains inserted. The PC's operating system may try to reboot from the SD card and be unable to do so.

Another option for viewing inspection video and photos on a PC is to use the supplied USB cable to link to the computer. The first time you connect the H16 to a computer in this way, you will be prompted that "Driver Software is Being Installed." The final Driver Software Installation dialog box advises that "Your device is ready to use" and specifies the following:

USB Mass Storage Device	✓Ready to use
Sunplus Sunplus SPCA436 USB Device	✓Ready to use

As the notifications make clear, with the USB cable connected your computer will treat the SD card in the H16 as an external disk drive named Sunplus SPCA436. While the connection is made, however, you cannot view real-time videos on the H16's LCD, a TV monitor, or your computer. You cannot even record videos or take photos and store them on the SD card. Connecting the cable powers off the H16. The only benefit of using the USB cable is that you do not have to remove the SD card to view its content on a PC.

Details of the SD's file structure are worth mentioning because assigned file names contain useful information. The figure below illustrates the hierarchy. It shows that the SD card contains one folder named "DCIM" and one subfolder named "100MEDIA". The 100MEDIA folder contains all stored photo and video files, identified by their.JPG and .ASF extensions. **You should not rename the DCIM and 100MEDIA folders while the SD card is inside your PC or connected to it. If you rename either folder, the H16 will fail to recognize the SD card the next time you plug it into the console.**

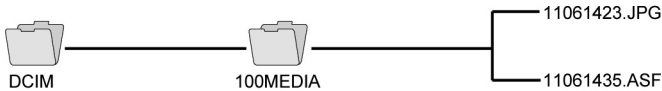

The 8-digit file names identify the date and time when the file was created. The first two digits represent the month and day, and the last six digits represent the hour, minute and second. For example, the upper file name shown above identifies a photo file that was created on January 1 at 06:14:23 a.m. The lower file name identifies a video file that was created on the same day at 06:14:35 a.m.

The H16's file-naming convention uses the letters A through C to represent the months October through December, and the letters A through V to represent days of the month from 10 through 31. For example, a file created on October 11 would begin with the letters AB (A for 10 and B for 11). As another example, a file created on November 30 would begin with the letters BU (B for 11 and U for 30).

Finally, the file-naming convention uses military (24-hour) time. For example, a name with the last six digits 142531 would indicate a file created at 02:25:31 p.m.

NAVIGATING THE MAIN MENU

The main menu of the H16 provides access to the following housekeeping and operational functions:

- Bulk file erasure
- Video exporting
- Setting the date and time
- Choosing a display language
- Selecting a TV format and adjusting video attributes
- Enabling/disabling and adjusting the Auto Power Off function

Menu mode has a hierarchical structure and uses prompts and dialog boxes familiar to anyone who has used an Automated Teller Machine (ATM). The only constraint on using the menu is your own response speed. **If no selection is made within 10 seconds following Menu mode startup, the console will automatically revert to Preview mode.** The same time constraint applies to selections within submenus. **If you do not respond to a prompt (indicated by a flashing word or line of text) within 10 seconds, the H16 will switch back to Preview mode**—its default operating state.

To access the main menu, press the **OK** button to enter Menu mode. Doing so brings up the screen shown at right.

To navigate the main menu, use the **▲** and **▼** buttons to move up and down until the parameter you wish to change is highlighted and flashing in green. Then push the **OK** button to select it and call up its submenu.

The **DELETE ALL FILES** line gives you two options (yes and no) that can be selected using the **▲** and **▼** buttons. The sequence is similar to the previously described procedure for deleting an individual photo or video.

The **AV OUTPUT** line allows you to send the real-time video stream shown on the display unit out through the unit's TV out jack to an NTSC or PAL TV monitor. The H16's display will turn black until you select this option again. Before activating this function, make the physical connection described in the "Viewing Live Video on a TV Monitor" section.

The **DATE/TIME SETUP** line allows you to set the H16's calendar and clock. Doing so is necessary only if you wish to keep track of your photo and video files by date and time.

When **DATE/TIME SETUP** is selected, the screen that appears has the year flashing in green. To increase the value, press the **📅** button. To decrease the value, press the **🕒** button. Once you have set the year, advance to the next field—the month—by pressing the **▼** button. Set the month as you did the year, by using the **▲** and **▼** buttons to increase or decrease the value by one unit per button press. Repeat this process until all six date and time components have been set. To back up from any field to the previous field, press the **▲** button.

The bottom line of the **DATE/TIME SETUP** screen also allows you to choose whether or not to superimpose the date and time on the display in Preview mode. The default condition is "display off", meaning the date and time are not displayed. To always superimpose the date and time, navigate down to the bottom line until the word **OFF** below the word **DISPLAY** is flashing green. Then push either the **📅** or **🕒** button to change the flashing word to **ON**. Finally, press the **OK** button to save the setting.

The **LANGUAGE** line of the main menu allows you to view the main menu, as well as the **DELETE** screens for individual photos and videos, in any of 14 languages (English, Spanish, Italian, French, German, Portuguese, Traditional Chinese, Simplified Chinese, Japanese, Danish, Dutch, Polish, Russian and Bulgarian). Use the **▲** and **▼** buttons to navigate to the language you wish to use and then push the **OK** button.

The **VIDEO FORMAT** line enables you to choose either **NTSC** or **PAL** formatting of the videos you export to a TV monitor. Press either the **▲** and **▼** button to make your choice and then push the **OK** button to save the setting.

Pressing the **🕒** button with either **NTSC** or **PAL** flashing in green on the **VIDEO FORMAT** submenu opens a sub-submenu with the following lines: Brightness, Contrast, Hue and Saturation. You can use this submenu to change any of those four video attributes from the default factory settings.

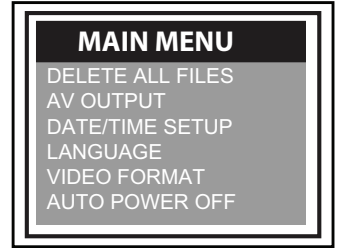

The default factory settings are: 00 for Brightness, 40 for Contrast, 00 for Hue, and 50 for Saturation. To change the value of any attribute, navigate to its line and press the **OK** button once its name begins flashing in green. The screen will then go dark except for the name of the attribute at the top. To increment the value from the factory default value, press the ▼ button (the opposite of what you'd expect). To decrement the value, press the ▲ button (again, the opposite of what you'd expect).

There are 256 options for the value of each video attribute, and the attributes are identified and ordered by hexadecimal (base 16) numbers. For example, pressing the ▼ button to increment the value 09 produces 0A (the number 10 in base 16 notation); further increments yield 0B through 0F (the numbers 11 through 15). Incrementing 0F produces the value 10 (the number 16 in hexadecimal notation). Similarly, incrementing 19 produces the value 1A; further increments yield 1B through 1F. Incrementing 9F produces A0, further increments produce A1 through A9, and further increments produce AA through AF. Incrementing AF produces BA, and so on, through FF (the number 255 in hexadecimal notation). Incrementing FF completes the cycle, producing a value of 00.

The **AUTO POWER OFF** line of the main menu is not visible on the screen that first appears after you press the **OK** button to put the H16 into Menu mode. To show the line, scroll down past the **VIDEO FORMAT** line. When the **AUTO POWER OFF** line appears, flashing in green, press the **OK** button.

By default, the **AUTO POWER OFF** function of the H16 is disabled. To enable it, and to choose how quickly to power off the instrument following a period of inactivity, navigate to one of the four options (5, 10, 15 or 30 minutes) and press the **OK** button. To re-disable the function later, enter Menu mode, scroll down to the **AUTO POWER OFF** line, press the **OK** button, select **DISABLE** and press the **OK** button again to save the setting.

ATTACHING A MIRRORED VIEWING TIP (OPTIONAL)

The DCS1600 system includes three mirrored viewing tips that screw onto the end of the supplied probe or any other compatible probe. To attach any of these tips:

1. Pull off the probe's rubber protective cap.
2. Unscrew and remove the black metal thread protector ring, as shown below at left.
3. Remove the blue circular protective film from the mirrored viewing tip by pulling on its tab.
4. Screw the viewing tip onto the camera head by turning it clockwise, as shown below at right. Keep turning until the tip can travel no further.
5. After using and removing the mirrored viewing tip, remember to reinstall the black metal thread protector ring by screwing it onto the camera head.

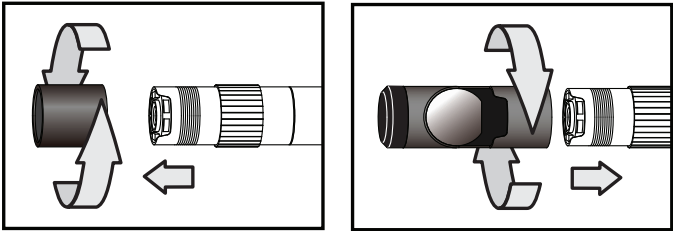

SPECIFICATIONS

H16 CONSOLE

Display Type	Color TFT LCD
Display Size	3.5 in (89mm) diagonal
Display Resolution	320 by 240 pixels (QVGA)
Video Recording Resolution	320 x 240 pixels (QVGA)
Video File Format	.asf
Photo Recording Resolution	640 x 480 pixels (VGA)
Photo File Format	.jpg
Video Out Formats	NTSC, PAL
Video Frame Rate	30 fps
Compression Format	Compatible with MPEG4
Signal-to-Noise Ratio	42dB or greater
Recording Medium	Standard-size SD card
Interfaces	AV out, USB 2.0
Languages	English, Spanish, Italian, French, German, Portuguese, Traditional Chinese, Simplified Chinese, Japanese, Danish, Dutch, Polish, Russian, Bulgarian
Power Source	Rechargeable 3.7V Li-ion battery
Power Consumption	1.8A @ 5.5VDC
Operating Temperature	-4° to 140°F (-20° to 60°C)
Storage Temperature	-4° to 140°F (-20° to 60°C)
Recharge Temperature	32° to 104°F (0° to 40°C)
Console Dimensions	8.5 x 4.7x 1.4 in. (215 x 120 x 36mm)
Console Weight	13.4 oz (380g)

P16181SR-M FLEXIBLE-OBEDIENT PROBE

Length	1m (3.28 ft)
Diameter	5.5mm (0.22 in.)
Depth of Field	0.4 to 12 in. (10 to 300mm)
Field of View	46° (horizontal), 34° (vertical), 56° (diagonal)
Resistances	To water, oil & dust per IP67 standard

OPERATING, MAINTENANCE & TROUBLESHOOTING TIPS

- Never remove the SD card while taking a picture or recording a video. Doing so may damage the card and erase or corrupt the photo or video.
- If the LCD suddenly goes dark, the first two things to check are the integrity of the console's connection to the probe and the charge of the console's battery. The reason for the failure also could be that you have forgotten to remove the red rubber cap protecting the probe tip.
- If live video begins to look spotty, streaky or intermittent, the likely reason is an under-charged battery. Plug in the AC adapter/battery charger immediately.
- Video recording requires an SD card with a fast writing speed. For maximum video quality, General recommends SD cards with a writing speed of 80X or higher.
- If the console "freezes" (pushing buttons has no effect) like a computer, straighten out a paper clip and use one end to press the Reset button on the back of the console (Fig. 1, Callout 15).
- Avoid using corrosive liquids such as alcohol to clean either the LCD or the probe. To clean the camera lens and LEDs, use a cotton swab and a small amount of cleaning solution. To clean the LCD, use the provided cloth, cotton swabs and liquid. To clean the housing of the console, use a soft, dry cloth.
- Operate and store the H16 only in a cool (under 140°F or 60°C), dry, well-ventilated place. Avoid exposing the unit to sunlight for long periods of time.
- To avoid damaging the console, use only compatible probes and accessories.
- The P16181SR-M probe is flexible to make it easy for you to inspect hard-to-reach areas. Never insert or bend it by force, and never over-bend any part of the probe. Specifically:
 - Do not bend the last 1 to 2 inches (25 to 50mm) of the probe by more than 70°
 - Do not bend the probe at any other point by more than 90°

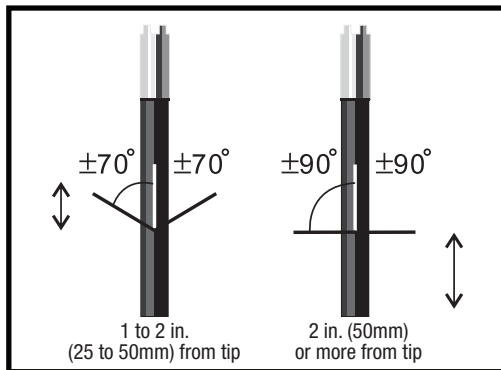

- To avoid permanently damaging the delicate wires and fiber optic cables inside the probe, never curl it into a circle with a diameter of less than 6 in. (150mm).
- Never use the probe or camera head to modify surroundings or to clear pathways or clogged areas.
- The camera head, LEDs and thread protector ring are waterproof, but not acid-proof or fire-proof. Do not touch acidic, corrosive or hot materials or they will ruin the head.
- Cover the camera-tipped end of the probe with the protective rubber cap when not using it.
- Unless you wish to install a mirrored viewing tip, do not unscrew the thread protector ring from the camera head.

- When inspecting a vehicle, shut off the engine. Metal and liquid under the hood may be hot. Do not get oil or gas on the camera head.
- If condensation forms inside the camera lens, let it evaporate before using the probe again.
- Do not try to disassemble any part of the probe. Doing so creates an electrical hazard, could damage the probe, and voids the limited warranty.
- Do not use any corrosive liquid—such as alcohol—to clean the probe body or camera head. Use a cotton swab and a mild fluid detergent to clean the body and head.

COMPATIBLE PROBES

The table below lists and describes the probes compatible with the H16.

Model No. (SKU)	Probe Description	UPC	Camera Head Diameter	Probe Length	Depth of Field	
P16ART-1SM	Soft Metal Articulating Probe	01418 9	6mm (0.23 in.)	1m (3.28 ft.)	0.4 to 12 in. (10 to 300mm)	
P16ART-2SM		01476 9		2m (6.6 ft.)		
P16ART-3SM		01500 1		3m (9.8 ft.)		
P16HPART	VGA Resolution Articulating Probe	01579 9		1m (3.28 ft.)		
P16181SR-M	Flexible-Obedient Probe	01408 0	5.5mm (0.22 in.)	1m (3.28 ft.)		
P16182SR-M		01409 7		2m (6.6 ft.)		
P16183SR-M		01410 3		3m (9.8 ft.)		
P16181SM-M	Soft Metal Probe	01411 0		1m (3.28 ft.)		
P16183SM-M		01412 7		3m (9.8 ft.)		
P16185SM-M		01414 4		5m (16 ft.)		
P161810SM-M		01414 1		10m (32 ft.)		
P161830SM-M		01415 8		30m (98 ft.)		
P1839-M	Ultra-Slim Flexible- Obedient Probe	01424 0		3.9mm (0.15 in)	1m (3.28 ft.)	0.25 to 6 in. (6.4 to 150mm)
P16182-39		01556 8			2m (6.6 ft.)	
P16183-39		01557 5	3m (9.8 ft.)			
P1618FS-49	Switchable Front/Side View Flexible- Obedient Probe	01481 3	4.9mm (0.19 in)	1m (3.28 ft.)		
P16182-49		01554 4		2m (6.6 ft.)		
P16183-49		01553 7		3m (9.8 ft.)		
P16181HP	VGA Resolution Probe	01576 6	5.5mm (0.22 in.)	1m (3.28 ft.)	0.4 to 12 in. (10 to 300mm)	
P1618SV-1SM	Side View Soft Metal Probe	01407 3		1m (3.28 ft.)	0.25 to 6 in. (6.4 to 150mm)	
P1618SV-1SR	Side View Flexible- Obedient Probe	01406 6		1m (3.28 ft.)		
P16PIP	Pipe & Duct Inspection Probe & Reel Set	01578 0	28mm (1.1 in.)	22m (72 ft.)	0.4 in. (10mm) to infinity	

WARRANTY INFORMATION

General Tools & Instruments' (General's) DCS1600 High-Performance Recording Video Borescope System is warranted to the original purchaser to be free from defects in material and workmanship for a period of one year. Subject to certain restrictions, General will repair or replace this instrument if, after examination, the company determines it to be defective in material or workmanship.

This warranty does not apply to damages that General determines to be from an attempted repair by non-authorized personnel or misuse, alterations, normal wear and tear, or accidental damage. The defective unit must be returned to General Tools & Instruments or to a General-authorized service center, freight prepaid and insured.

Acceptance of the exclusive repair and replacement remedies described herein is a condition of the contract for purchase of this product. In no event shall General be liable for any incidental, special, consequential or punitive damages, or for any cost, attorneys' fees, expenses, or losses alleged to be a consequence of damage due to failure of, or defect in any product including, but not limited to, any claims for loss of profits.

RETURN FOR REPAIR POLICY

Every effort has been made to provide you with a reliable product of superior quality. However, in the event your instrument requires repair, please contact our Customer Service to obtain an RGA (Return Goods Authorization) number before forwarding the unit via prepaid freight to the attention of our Service Center at this address:

General Tools & Instruments
80 White Street
New York, NY 10013
212-431-6100

Remember to include a copy of your proof of purchase, your return address, and your phone number and/or e-mail address.



Specialty Tools & Instruments

GENERAL TOOLS & INSTRUMENTS

80 White Street

New York, NY 10013-3567

PHONE (212) 431-6100 FAX (212) 431-6499

TOLL FREE (800) 697-8665

e-mail: sales@generaltools.com

www.generaltools.com

DCS1600 User's Manual

Specifications subject to change without notice

©2012 GENERAL TOOLS & INSTRUMENTS

NOTICE - WE ARE NOT RESPONSIBLE FOR TYPOGRAPHICAL ERRORS.

MAN#DCS1600 7/5/12