

**OPERATING AND MAINTENANCE
INSTRUCTION MANUAL**

“DAVID-III”

MODEL 718

FM-STEREO PROCESSOR / GENERATOR

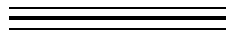

—— USER'S RECORD ——

Model 718 – Serial No. _____

Date Purchased _____

Warranty Card Mailed? —

OPERATING AND MAINTENANCE INSTRUCTION MANUAL

“DAVID-III”
—— MODEL 718 ——

FM-STEREO PROCESSOR / GENERATOR

June, 2004



1305 Fair Avenue • Santa Cruz, CA 95060
TEL: (831) 458-0552 • FAX: (831) 458-0554

Visit our Website: www.inovon.com

TABLE OF CONTENTS

Section I - INTRODUCTION

MODEL 718 PRODUCT DESCRIPTION	3
History • Features	
MODEL 718 TECHNICAL SPECIFICATIONS	4
BLOCK DIAGRAM	5

Section II - INSTALLATION

UNPACKING AND INSPECTION	6
MOUNTING	6
Rack Requirement • Heat Dissipation	
AC (MAINS) POWER	7
Fuseholder • Mains Voltage Selector • Power Cord	
RADIO FREQUENCY INTERFERENCE (R F I)	7
Location • Ground Loops	
LINE INPUT AND RANGE SELECTION	8
Input Connections • Unbalanced Inputs	
Input Gain Range • Gain Jumpers	
PRE-EMPHASIS SELECTION	9
COMPOSITE/MPX OUTPUT	9

Section III - SETUP AND OPERATION

PANEL CONTROLS AND INDICATORS	10
NORMAL SETUP PROCEDURE	12
INPUT GAIN Calibration • MPX LEVEL Adjustment	
TRIBAND PROCESSING SETUP GUIDELINES	14
AGC Section Notes • MASTER DRIVE • BASS and BRILLIANCE	
FINAL PEAK CONTROL	16
PIPP* LIMITER • COMP. CLIPPING	
HOW DOES IT SOUND?	17

Section IV - CIRCUIT DESCRIPTIONS

INTRODUCTION	18
Component Annotation	
A PWM PRIMER	18
PWM Gain Control • Feedforward Processing	
“Soft Knee” • The PWM ‘Ramp’ Waveform	

PWM RAMP CIRCUITS	20
Master Clock • Compressor/Limiter Ramp • AGC Ramp	
SIGNAL PATH CIRCUITRY	21
INPUT STAGES	21
Line Input Balancing • INPUT LEVEL Control • AGC Stages	
AGC Gating • AGC Metering • Pre-Emphasis • Program Pre-Clipping	
TRIBAND PROCESSING	23
Band Division • Band Rectifiers • Midband Time Constants	
Bass Processing • Brilliance Processing • PWM Comparators	
Gain Reduction Indicators • Combining Amplifier	
THE PIPP* LIMITER	27
LOW-PASS FILTER	28
Filter Overshoots • Overshoot Compensation	
The Low-Pass Filter	
PILOT AND SUBCARRIER SYNTHESIS	29
Clock • Pilot Generation • 'Center Sampling' • Subcarrier Generation	
Composite Clipper • Combining Amplifier • Output Filter	
Output Phase and Equalization Trimmers	
POWER SUPPLY.....	31
YOUR NOTES AND DOODLES.....	31
 Section V - APPENDIX	
EXPLANATION OF PARTS LISTINGS	34
PARTS LISTINGS	34
PARTS SUPPLIERS.....	36
SCHEMATIC DIAGRAMS	38
INOVONICS WARRANTY	(INSIDE BACK COVER)

Section I

INTRODUCTION

MODEL 718 PRODUCT DESCRIPTION

History Inovonics introduced the first *DAVID* (as in David vs. Goliath) FM-Stereo Processor / Stereo Generator in 1992. The original Model 715 was the hallmark of simplicity, having been developed to address the more basic of FM radio broadcasting needs.

The next generation *DAVID-II* came out in 1995. It included a redesigned pulse-width-modulation audio processing section, which helped to expand the applicability of this updated product to broadcast situations where perceived loudness and modulation density were considered germane to the broadcaster's success.

This third-generation *DAVID-III* brings even more features and functionality to the modestly priced *DAVID* series, along with a bigger, bolder and brighter sound. Wider AGC capture, multiband processing, equalization adjustments and a proprietary final limiting system make the *DAVID-III* the rival of far more expensive alternatives.

Features Leading features of the *DAVID-III* include:

- Comprehensive PWM audio processing with gain-riding AGC, three bands of compression and limiting, and adjustable bass and brilliance EQ.
- Inovonics' unique PIPP* final limiter, which assures full carrier modulation with all types of program material.
- A stereo-generator section that utilizes digital-synthesis techniques for best stereo separation and rock-stable operation.
- A built-in, user-adjustable composite clipper.
- A product that is simple to install and very easy to use, the *DAVID-III* is built with easy-to-find 'generic' components for easy servicing anywhere in the world.

MODEL 718 TECHNICAL SPECIFICATIONS

Frequency Response (through an appropriate de-emphasis network): $\pm 0.5\text{dB}$, 20Hz-15kHz; -60dB or better at 19kHz.

Noise:

Better than 70dB below 100% modulation in demodulated L/R audio, 20Hz-16kHz. Individual digital noise components above 54kHz are -70dB or better.

Distortion:

$<0.5\%$ THD in baseband and subcarrier at 95% modulation with PIPP* limiter defeated; $<1.5\%$ at any level of modulation with PIPP* limiter engaged.

Stereo Separation (L \rightarrow R or R \rightarrow L): $>55\text{dB}$, 20Hz-16kHz.

Crosstalk (M \rightarrow S or S \rightarrow M):

Nonlinear crosstalk is better than -50dB , 50Hz-15kHz. Linear crosstalk (through processing and filters) is better than -40dB .

L/R Program Line Inputs:

Active-balanced/bridging XLR inputs accept nominal program line levels between -15dBu and $+10\text{dBu}$.

AGC Amplifier:

Unobtrusive, average-weighted correction for long-term input level variations; $\pm 15\text{dB}$ capture range.

Pre-emphasis:

$75\mu\text{s}$ or $50\mu\text{s}$ selected by circuit board jumpers.

3-Band Processing:

Tight peak control in three asymmetrical frequency bands with secondary platform time constants to compress program dynamics with average-value weighting. Crossover frequencies at 100Hz and 4kHz. (See Figure 7, Page 24.)

Processing Control:

Master processing drive is adjustable between 0dB and more than 12dB, equating to a corresponding reduction in program dynamics and apparent loudness increase.

Equalization:

Adjustment range relative to original program balance:
BASS: -3dB to $+9\text{dB}$
BRILLIANCE: -3dB to $+6\text{dB}$
(See Figure 4, Page 15.)

PIPP* Final L/R Limiter:

Patented "Polarity-Independent Peak Processing" circuitry assures full modulation of the FM carrier despite abnormalities in the program waveform geometry.

Digital Synthesis Sampling Rate:

608kHz (16X subcarrier oversampling).

Composite Processor:

Adjustable from 0dB to 3dB clipping of the 100%-modulated multiplex waveform prior to pilot injection.

Stereo Pilot:

19kHz, $\pm 1\text{Hz}$; injection level adjustable between 6% and 12%, relative to 100% modulation.

Composite (Multiplex) Output:

Adjustable between 1V p-p and 8V p-p; 75-ohm source impedance.

Power Requirements:

105-130VAC or 210-255VAC, 50/60Hz; 15 watts.

Size and Weight:

$1\frac{3}{4}$ "H x 19"W x 8"D (1U);
8 lbs (shipping).

BLOCK DIAGRAM

Figure 1, below, is a simplified Block Diagram of the *DAVID-III*. A full set of schematic diagrams appears in the Appendix, Section V.

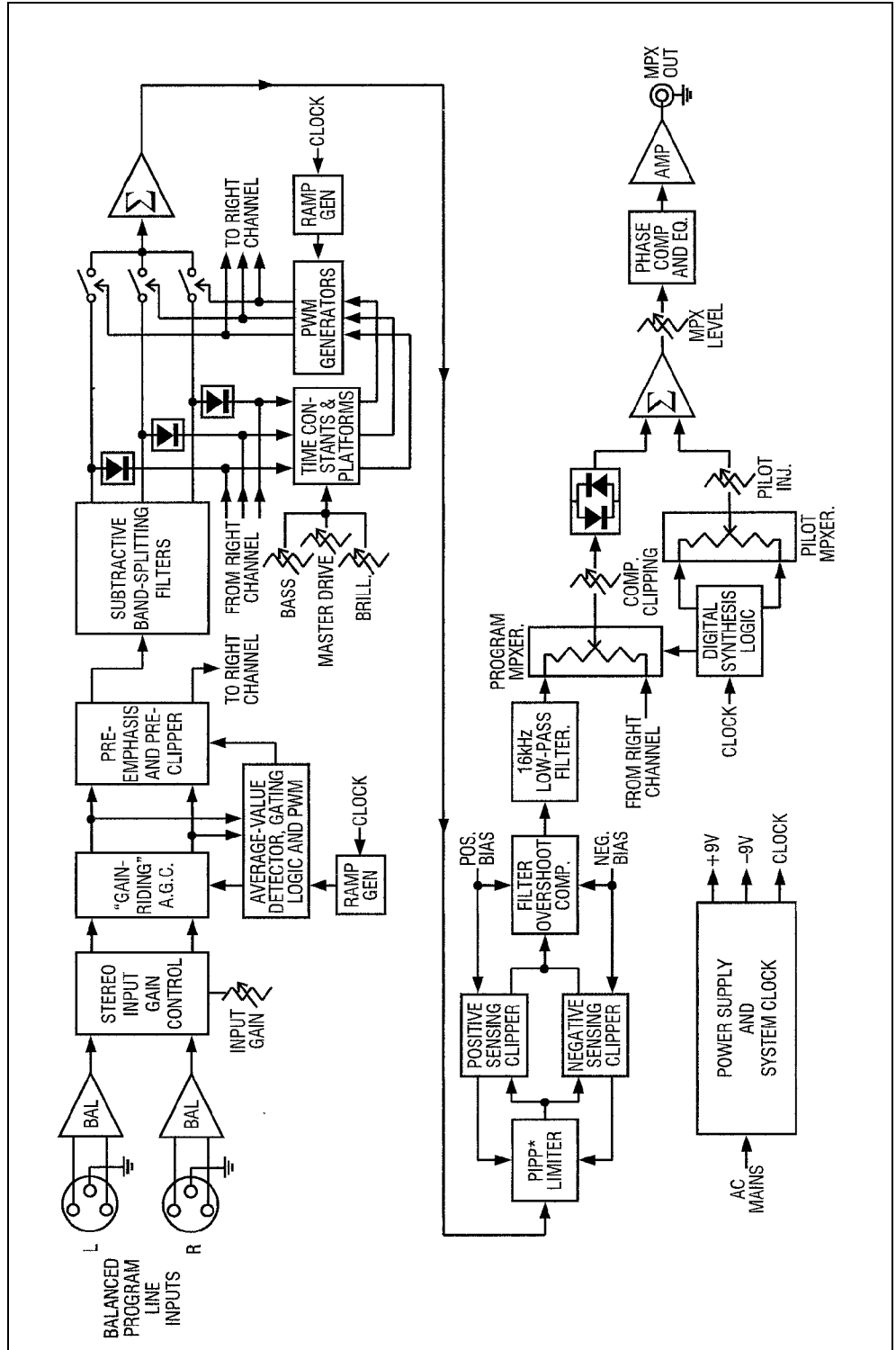

Figure 1 - Block Diagram, *DAVID-III* — Model 718

Section II

INSTALLATION

UNPACKING AND INSPECTION

As soon as the equipment is received, inspect carefully for any shipping damage. If damage is suspected, notify the carrier at once, and then contact Inovonics.

We recommend that you retain the original shipping carton and packing materials, just in case return or reshipment becomes necessary. In the event of return for Warranty repair, shipping damage sustained as a result of improper packing for return *may invalidate the Warranty!*

IT IS VERY IMPORTANT that the Warranty Registration Card found at the front of this Manual be completed and returned. Not only does this assure coverage of the equipment under terms of the Warranty and provide a means of tracing lost or stolen gear, but also the user will automatically receive specific **SERVICE OR MODIFICATION INSTRUCTIONS** should the factory issue them.

MOUNTING

Rack Requirement

The *DAVID-III* mounts in a standard 19-inch equipment rack and requires only 1¾ inches (1U) of vertical rack space. The use of plastic washers is recommended to protect the painted finish around the mounting holes.

Heat Dissipation

Consuming about the same power as a couple of night-lights, the 718 itself generates negligible heat. The unit is specified for operation within an ambient temperature range extending from freezing to 120°F/50°C. But because adjacent, less efficient equipment may radiate substantial second-hand heat, be sure that the equipment rack is adequately ventilated to keep its internal temperature below the specified maximum ambient.

AC (MAINS) POWER

- Fuseholder** The fuseholder is at the far left of the front panel. Apply downward pressure and pull the cap outward to access the 5mm mains fuse. Note that the cap has space for a spare fuse as well, though a spare has not been included due to our ongoing diligence in keeping costs low. The cap is reseated by reversing the removal process. This fuse also serves as a front-panel emergency power disconnect for the *DAVID-III*.
- Mains Voltage Selector** Unless specifically ordered for export shipment, the *DAVID-III* is set at the factory for operation from 115V, 50/60Hz AC mains. This can be confirmed by checking the designation beneath the mains connector on the rear panel. The *inappropriate* voltage and fuse value will have been crossed out at the factory with an indelible felt marker.
- To change the mains voltage, first remove the top cover of the unit. A clearly marked slide switch is next to the AC mains connector on the circuit board. *With power disconnected*, use a small screwdriver to set the switch for 115VAC or 230VAC operation.
- Be sure to install the appropriate fuse listed on the rear panel. You can remove the factory strikethrough with a carcinogenic solvent and then cross out the inappropriate marking with an indelible felt pen.
- Power Cord** The detachable IEC-type power cord supplied with the encoder is fitted with a North-American-standard male plug. The individual cord conductors may be color-coded in either of two ways:
- 1) In accordance with US standards:
BLACK = AC "HOT" WHITE = AC NEUTRAL
GREEN = EARTH GROUND
 - 2) To European CEE standards:
BROWN = AC "HOT" BLUE = AC NEUTRAL
GRN/YEL = EARTH GROUND

RADIO FREQUENCY INTERFERENCE (R F I)

- Location** Although it is natural for the *DAVID-III* to be installed alongside high-power transmitters, please practice reasonable care and common sense in locating the unit away from *abnormally* high RF fields.
- Ground Loops** Because the unbalanced COMPOSITE/MPX OUT connector of the *DAVID-III* is referenced to chassis ground, a mains frequency or RF ground loop could be formed between output cable shield ground and the AC power cord ground. A 'ground-lifting' AC adapter may well remedy such a situation, though the chassis somehow must be returned to earth ground for safety. Generally, being screwed-down in the equipment rack will satisfy the safety requirement.

LINE INPUT AND RANGE SELECTION

Input Connections The *DAVID-III* has electronically-balanced (transformerless) left- and right-channel PROGRAM LINE INPUTS. These appear as XLR female connectors on the rear panel. As these are bridging, high impedance inputs, they provide no termination for the console or other equipment that feeds the *DAVID-III*. Most professional equipment nowadays has low output impedances and high input impedances. The concept of 600-ohm “line matching” dates from the age of transformer coupling and is rooted in ancient telephone practices. With few exceptions, audio line impedance matching is ridiculed by today’s hip broadcasters (you) and equipment manufacturers (us).

Unbalanced Inputs The *DAVID-III* may be fed from gear with unbalanced outputs. Disco mixers have proven perfectly serviceable for an installation on a tight budget. For unbalanced lines, the single center conductor of the shielded input lead should be connected to Pin 2 of the XLR connector, and the shield connected both to Pin 1 and to Pin 3.

Input Gain Range The *DAVID-III* can accommodate line-level program inputs with a nominal “Zero-VU” level between -15dBu and $+10\text{dBu}$. This 25dB range is divided into two more manageable, overlapping gain ranges that are selected by a series of four internal jumpers.

As shipped, the *DAVID-III* is set up for professional level inputs that lie in the 0dBu to $+10\text{dBu}$ range. Most console and STL receiver outputs will fall into this range; $+4\text{dBu}$ and $+8\text{dBu}$ are typical program line levels.

Lower levels, between -15dBu and 0dBu , may be encountered when interfacing with ‘semi-pro’ gear or with feeds from lossy studio-transmitter telephone line circuits. Extra gain for the low level range is enabled by changing jumpers beneath the top cover.

Gain Jumpers Under the top cover and just behind the left channel input connector you will find four, 3-pin jumper strips. These are identified as JP2 through JP5 in the circuit board legend, and each has a push-on jumper ‘shunt.’ LO and HI designations identify the jumper position for low-level and high-level inputs, respectively, and all four jumpers must be set identically. This is shown in Figure 2, below.

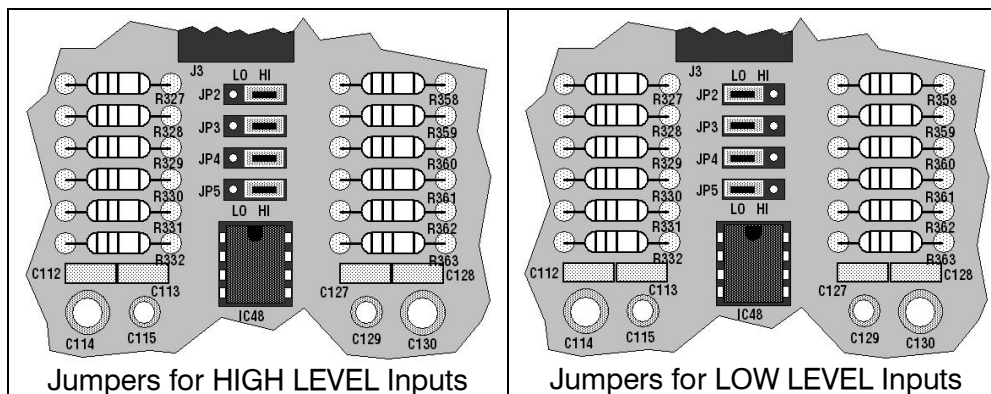

Figure 2 - Input Gain Range Jumpering

PRE-EMPHASIS SELECTION

The *DAVID-III* supports both the 75-microsecond FM broadcasting pre-emphasis standard common to the Western Hemisphere and parts of the Orient, and the 50-microsecond standard used in Europe and Asia. Pre-emphasis appropriate to the delivery destination is set at the factory, but this can be changed if necessary.

Beneath the top cover, locate the two, three-pin jumper strips labeled JP1 and JP6. These are located in the rows of components behind the left channel XLR connector and just either side of IC49.

The push-on jumper ‘shunts’ may be moved between the 50 and 75 positions, and both jumpers must be set identically as shown in Figure 3, below.

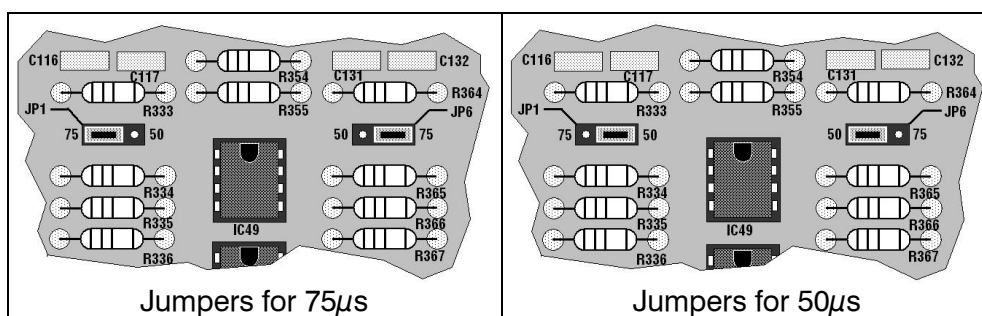

Figure 3 - Pre-Emphasis Jumpering

COMPOSITE/MPX OUTPUT

The unbalanced COMPOSITE/MPX OUT BNC connector on the rear panel of the *DAVID-III* has a resistive source impedance of 75 ohms. This allows cable runs of moderate length (to about 50 feet) to the exciter or microwave link input. If the cable is more than just a few feet, the cable itself should have a 75-ohm characteristic impedance and be terminated in 75 ohms at the far end.

A Stereo Generator must always be connected to an exciter or link (STL) input specifically intended for multiplex stereo. This is a wideband, “flat” input, not a monaural program line input with its own pre-emphasis network. Program signal pre-emphasis is imparted by the *DAVID-III*.

Section III

SETUP AND OPERATION

PANEL CONTROLS AND INDICATORS

A brief description of the front-panel controls and indicators follows. Explanations are arranged right-to-left, which is the order of the signal path through the *DAVID-III*. Please at least skim over this section to verify that our terminology agrees with your understanding. More detailed notes on *DAVID-III* operation follow this initial descriptive information.

The screwdriver-adjusted, front-panel multiturn trim controls require *fifteen to twenty complete rotations* of the adjusting screw to cover their total operating range. Depending on the manufacturer, the end of the range may, *or may not*, be identified by a “click-click” sound or other audible/tactile sensation.

INPUT GAIN

A single control adjusts input sensitivity for both the left and the right program channel inputs. The single control makes *DAVID-III* setup easier, but provides no means of correcting for channel imbalance. Stereo imbalance should be addressed at the source of this problem.

The INPUT GAIN control has a 12dB range, which is extended by the input gain range jumpering options described on Page 8. INPUT GAIN is adjusted using normal program material to maintain the indicated AGC gain in the center of its operating region.

GATE OPEN

DAVID-III AGC is “gated,” meaning that during brief pauses in the program the gain is locked to prevent background sounds from slowly increasing to unnatural proportions. The green GATE OPEN indicator will remain continuously lighted during most music programming, but will blink off during pauses in speech.

A.G.C. GAIN

This series of seven LEDs displays the amount of correction in effect for long-term variations in the program level. The AGC circuit is average-responding and is left/right correlated; that is, the overall circuit gain is controlled by the *greater* of the left or the right channel signals. This measure is incorporated to preserve the program’s stereo image.

AGC correction rate is intentionally quite slow. With a conscientious operator at the console, the indicated A.G.C. GAIN should always hover near the 0dB indicator.

The safe operating zone of the AGC circuit is within the central three green LEDs. Consistent operation at +10dB or -10dB suggests that the INPUT GAIN control should be readjusted. If either the +15dB or the -15dB indicator becomes lighted to full brightness, the input program signal is definitely *out of limits* and the reason should be found and corrected at once.

MASTER DRIVE

This is the first adjustment for ‘audio signature’ in the processing chain. It represents the input level control to the Triband Processing section of the *DAVID-III*. As well as adjusting the program level, this control also affects dynamic compression release characteristics, which become more aggressive as the control is rotated clockwise. Additional details are presented under TRIBAND PROCESSING SETUP GUIDELINES on Page 14.

G/R

The three sets of G/R (Gain Reduction) LEDs provide a visual display of the approximate amount of peak-plus-average gain reduction in effect in each of the three processing bands, as well as giving an indication of the compression release characteristic.

The green 0dB indicator remains lighted at full brilliance with full gain (no processing) in the attendant band. When the -12dB LED is lighted fully, 12dB or more limiting and compression is in effect. Equal brightness in both LEDs would suggest about 6dB of gain reduction. With a little practice it should not be difficult to visually interpolate for intermediate G/R values, as well as to differentiate the fast limiter release from the slower compression platform timing characteristic.

BASS and BRILLIANCE

Because the effect of these two controls is largely dependent on dynamics of the program source, they cannot be thought of as simple EQ (equalization) adjustments. What these afford is leverage over the relative amount of *total energy* at the frequency extremes of the program audio spectrum. Refer to the more detailed discussion under the TRIBAND PROCESSING SETUP GUIDELINES on Page 14.

PIPP* LIMITER

PIPP* is an acronym for *Polarity-Independent Peak Processing*. In a nutshell, positive and negative program peaks are limited independently of one another. This ensures full modulation of the FM carrier and an audible increase in program ‘perceived loudness.’ Refer to the more detailed discussion under the FINAL PEAK CONTROL subhead on Page 16.

- COMP. CLIPPING** In the fully counterclockwise OUT position of this control, an output safety clipper catches only those occasional, very fast peaks or overshoots that sneak by the earlier protection circuitry in the signal path. As COMP. CLIPPING is rotated clockwise, the level applied to this safety clipper is increased by the dB value shown by the panel markings.
- MODE** MODE simply switches the operation of the *DAVID-III* between normal multiplex stereo transmission and forced-monaural operation. In the MONO mode, both the 19kHz stereo pilot and the 38kHz subcarrier are turned off, and left and right program channels are summed.
- FUSE / DISCONNECT** The front-panel fuseholder also provides a means of disconnecting AC mains power in an emergency. Push the fuseholder cap down and pull it away from the panel to interrupt power.

NORMAL SETUP PROCEDURE

This setup procedure presupposes a normal installation with the *DAVID-III* PROGRAM LINE INPUT fed *directly* from the output of the audio console, and with a *direct* connection from the COMPOSITE/MPX OUTPUT to the wideband input of a transmitter exciter. Variations from these conditions, such as an intermediate STL (or other link) in either the input or the output path of the *DAVID-III* may call for considerations not addressed here.

At this point the *DAVID-III* should be installed in the program chain with power applied. The MODE switch should be in STEREO and the PIPP* LIMITER switched ON.

INPUT GAIN Calibration The single INPUT GAIN adjustment controls both stereo channels simultaneously. It is set simply to center the AGC operating range with a nominal “Zero-VU” program line input of typical program material. If this procedure shows control range to be outside adjustment limits, recheck circuit board jumpering for Line Input Range Selection as described on Page 8.

With program from the console or link receiver feeding the *DAVID-III*, adjust the front-panel INPUT GAIN control so that the A.G.C. RANGE indicator hovers around the 0dB mark most of the time.

If this procedure is performed properly, and if the operator pays reasonable attention to console metering, the AGC GAIN indicators should normally hover around 0dB, and always remain in the “safe operating” zone between -10dB and +10dB.

MPX LEVEL Adjustments This part of the procedure is performed on-air under normal operating conditions and using typical program material. You must have access to the station’s Modulation Monitor. An RDS or SCA subcarrier should *not be connected* until Step 6.

PLEASE be certain that you understand operation of the Mod-Monitor, and that it is properly calibrated and connected to the correct transmitter RF sample point or has a solid off-air signal.

1. Put the Mod-Monitor in its Total Peak Modulation measurement mode with peak flasher(s) set to 100%.
2. *Just for this calibration procedure*, turn the MASTER DRIVE and COMP. CLIPPING controls fully clockwise (maximum).
3. With normal program fed to the *DAVID-III* (at a level that maintains A.G.C. GAIN in the center of its range), adjust the MPX LEVEL control for a Mod-Monitor indication of *frequent* 100%-modulation peaks.
4. Back-down the MPX LEVEL control slightly, so that the 100% peak flasher(s) light only occasionally.
5. Switch the Modulation Monitor to display the injection level of the 19kHz stereo pilot.
6. Adjust the PILOT INJ. control for a 9% Mod-Monitor reading of pilot injection.
7. OPTIONAL: If an RDS or an SCA subcarrier is to be transmitted, connect it to the proper combining point at this time. Using the Mod-Monitor or other means of reading the auxiliary subcarrier injection level, adjust the subcarrier level control for the proper injection. This is normally about 4% for an RDS subcarrier and 10% for an audio SCA.
8. Put the Mod-Monitor back into its Total Peak Modulation measurement mode and, if necessary, trim the MPX LEVEL control so that the peak flasher(s) indicate only *occasional* 100% peaks.
9. NOTE: Depending on current operating rules and practices, total peak carrier deviation *may be permitted* to exceed the customary 100%-modulation figure when SCA and RDS subcarriers are broadcast,. The station (or consulting) engineer should be aware of legal guidelines in effect and assume responsibility for any adjustment that results in a total modulation reading in excess of 100%.
10. *Decrease the* COMP. CLIPPING *and* MASTER DRIVE *controls to their normal operating values.* As a starting point, set COMP. CLIPPING to 1dB and MASTER DRIVE to +6dB.

TRIBAND PROCESSING SETUP GUIDELINES

Processor setup is obviously very subjective and will depend entirely on the station's format, the desired 'sonic signature,' and the needs, wants and whims of various station personnel. A few hints are provided here, some of which are redundant to information that has already been given with the identification of the various front-panel appointments.

AGC Section Notes

The slow, gain-riding AGC action of the *DAVID-III* departs from earlier versions in this series of processors. The response to program material is average-responding rather than peak-responding. The rationale behind our about-face on this issue has to do with the tendency toward greater and greater processing of music source material. Although the popular CD is only a consumer music format, it is nonetheless capable of a full 90dB dynamic range. Sadly, a statistical analysis of most CDs on the market will show total dynamics of 20dB or less, except for fade-ins and -outs.

An averaging response to program dynamics encourages the downstream Triband Processing section of the *DAVID-III* to work harder on source material with a greater dynamic range... as indeed it should. Under our previous position, 'pre-squashed' music would get just as much compression and peak processing as wide-dynamics live announce... certainly more than it needs. This would constitute a case of 'overprocessing' of the musical content of the program.

The correction rate of the AGC stage has been speeded-up from previous *DAVID* versions by a factor of four. The present value is about 2dB/second, just a bit slower than would result in audible dynamic alteration of the program, given the *averaging* response to music and speech.

MASTER DRIVE

This sets the amount of overall processing. When set at 0dB, there is little-if-any dynamic gain reduction ever in effect, except with program material having a high average-to-peak ratio; an unprocessed announce-microphone channel, for instance.

'Normal' MASTER DRIVE range extends from 0dB to +12dB. These figures reflect the approximate amount of program dynamics compression called into play, and to a subjective extent the amount of increase in loudness. Loudness increase will depend largely on the dynamic range of the unprocessed program material. Obviously if the source CD is already highly compressed there's not much that can be done to further decrease the average-to-peak ratio.

The designation MAX will be noted at full clockwise rotation of the MASTER DRIVE control. Between +12dB and MAX, Triband Processing release timing is jumped-up to its fastest rate. This ⁿth degree adjustment can yield a loudness increase, but at the expense of audible artifacts with some program material, notably solo voice. Please use discretion with this maximum setting.

A good starting point for MASTER DRIVE is +6dB. Listening tests with a variety of program material may suggest an alternative

BASS and BRILLIANCE

setting. Also, adjustment of BASS and BRILLIANCE may dictate a change in the MASTER DRIVE setting.

Circuit action of BASS and BRILLIANCE is threefold. First, the setting dictates to what extent midband gain reduction simultaneously controls the amount of reduction at the frequency extremes; that is, the amount of *coupling* between the bands. Secondly, as BASS and BRILLIANCE are rotated clockwise, not only do these bands decouple from the midband section, but they also are allowed to release *beyond* the final midband release point. Thirdly, clockwise rotation of these controls speeds up the release timing in the subject band. These three functions work together to create what we call *Spectral Loading*, best defined as an artificial buildup of *energy* at either or both of the frequency extremes. This is quite different from static (fixed) *equalization*.

When BASS and BRILLIANCE are set to 0dB, the Triband Processing section works almost like a single-band compressor. Tonal balance will be much the same as the unprocessed program input, though the program dynamic range will be restricted based on how MASTER DRIVE has been set. Rotating BASS and BRILLIANCE toward -3dB will cause a *reduction* of energy at the ends of the spectrum.

The BASS control gives up to 9dB of low-end Spectral Loading. BRILLIANCE, however, affords only a maximum 6dB. BRILLIANCE is purposely restricted because of FM broadcast system pre-emphasis. With high frequencies already accentuated by 10dB or more, attempts to create additional top-end sparkle or crispness in the program runs the risk of causing a sound that is either ‘brittle’ (clipped) or ‘mushy’ (excessively HF-limited). Exercise discretion with extremes in Spectral Loading, particularly at the top end.

Figure 4, below, illustrates the frequency range and leverage of the BASS and BRILLIANCE controls. Keep in mind that Spectral Loading is a *dynamic* function, and that maximum effect will depend largely on the tonal balance of the program material.

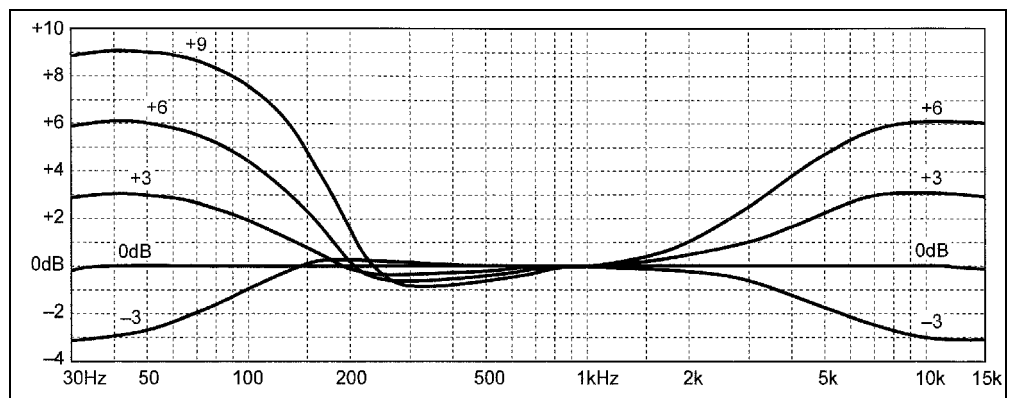

Figure 4 - “Spectral Loading” Range and Leverage

Note in Figure 4 that the BASS control shows a second-order Chebychev filter characteristic with the expected dip prior to boost and a peak prior to cut. This is a product of the band-splitting

architecture that actually gives an advantage in the *DAVID-III*. Note that the dip falls in the lower voice range. Thus when bass is boosted voices won't tend to become 'tubby.'

FINAL PEAK CONTROL

PIPP* LIMITER As previously defined, PIPP* is an acronym for *Polarity-Independent Peak Processing*. This function separates the gain control action between the positive and negative excursions of the program waveform, with the zero-volt DC baseline of the incoming signal as the point of reference.

This elementary explanation will undoubtedly elicit a horrified response of, "But that adds distortion!" Well, yes and no. The only truly undistorted waveform that we can measure, or perceive as a pure tone by ear, is a textbook sinewave. Because a sinewave is perfectly symmetrical, the PIPP* limiter acts equally on both the positive and the negative excursions and thus does not distort the wave shape in the slightest.

An asymmetrical waveform, on the other hand, most notably a solo musical instrument or speech, will have asymmetry and 'peakiness' removed by the PIPP* limiter. Does this imply that the waveform, by definition already full of harmonics (ie: *distortion!*) will further be 'distorted'? Technically, yes. A saxophone may sound more "saxophone-like" and speech will definitely have a different quality. But, after all, we are talking audio processing here, and sonic modification is par for the course.

Another possible concern might be that mucking-about with waveform symmetry could introduce a sufficient DC component to the program that the exciter frequency-reference PLL would unlock. Take comfort in the fact that audio program material is constantly changing, and DC offsets are short-lived. Not to worry.

The primary advantage of the PIPP* concept is full negative and positive deviation of the carrier with all types of program material. This adds up to a louder sound with a special added bonus of "beefier" bass. Now, if the PIPP* concept worries or offends you, or if you think it doesn't sound quite right, we have provided a little switch to disable the feature quickly and easily.

The two LEDs associated with the PIPP* limiter show circuit action in the separate and independent left and right channel limiters. The resting state of the LEDs is yellow. When positive excursions are being limited the LED goes red; when negative excursions are limited the LED turns green.

It is interesting to watch the constant color change of the two PIPP* LEDs as the program is worked-on, and especially to observe the symmetry difference between stereo channels. By operating on each channel independently, the PIPP* limiter actually introduces a

small additional amount of stereo difference information. This gives a little bit of ‘stereo enhancement’ at no extra charge.

Further discussion of the PIPP* limiting concept can be found in a ‘white paper’ on the Inovonics Website: www.inovon.com. PIPP* limiting is protected by US Patent No. 6,658,120.

**COMP.
CLIPPING**

Composite clipping has traditionally been the tool used to squeeze the very last bit of loudness from the processed FM program signal. Too much clipping of the multiplex signal can generate spurious harmonic products that clutter the baseband spectrum, interfering with the 19kHz pilot and compromising performance of RDS and SCA subcarriers.

In the *DAVID-III* the multiplex waveform is clipped *prior* to the point at which the 19kHz stereo pilot is inserted. This ensures that the pilot is not directly modulated, though the pilot is not protected from harmonic products that are generated as the program waveform is clipped at fractional intervals (mostly one-third and one-fifth) of the pilot frequency. The following tabulation is an approximation of the SGTM (Spectral Garbage) generated by composite clipping:

<u>COMPOSITE PROCESSING</u>	<u>PEAK VALUE OF CLIPPING PRODUCTS</u>
OUT	>60dB below 100% Mod.
1dB	50dB below 100% Mod.
2dB	45dB below 100% Mod.
3dB	40dB below 100% Mod.

Keep clearly in mind that crosstalk of program audio harmonic components into the RDS or SCA subcarrier region is exacerbated by composite clipping, so *use this feature sparingly!* Generally, 1dB of COMP. CLIPPING can be tolerated without harmful effect.

HOW DOES IT SOUND?

The foregoing overview of processor setup is intended only as a guide. Final decisions must be made based on extensive listening and not on the basis of numbers. The dB markings around the front-panel controls correlate well with what’s going on inside the *DAVID-III*, but not necessarily with what you may expect to hear.

Please make every effort to arrive at a setup that sounds good to you and to other station personnel for the *majority* of program content and over the *long term*. Resist the temptation to change settings because of how one or two specific music tracks sound; some songs simply sound awful with any processing... or without it, for that matter.

Section IV

CIRCUIT DESCRIPTIONS

INTRODUCTION

This Section details the circuitry of the Inovonics *DAVID-III*. Circuit descriptions refer to the six sheets of Schematic Diagrams contained in the Appendix, Section V, Pages 38 to 43.

Component Annotation

DAVID-III schematics may appear to have component reference designations assigned in a haphazard manner. Rather than to annotate the *schematic* in a logical sequence, we have instead chosen to designate the *components* on the circuit board in a logical top-to-bottom and left-to-right manner, following the physical placement of the parts in their neat little rows. It is our expectation that this practice will make any necessary troubleshooting easier, as a component can physically be located quickly following analysis of the schematic.

A PWM PRIMER

PWM Gain Control

The *DAVID-III* utilizes Pulse-Width Modulation techniques rather than VCAs (voltage-controlled amplifiers). This technology, as applied to broadcast audio processing, was pioneered by Inovonics in the early 1980s and has been refined over the years. PWM is a simple, colorless, quasi-digital method of linear gain control that avoids several hassles associated with more expensive and possibly single-sourced VCA integrated circuits. Our implementation of PWM utilizes the popular 4000-series CMOS parts that are dirt cheap and available in any civilized area.

PWM sets the gain of an analog circuit simply by sampling, or 'chopping,' the analog signal; that is, turning it on and off at a rapid rate. Consider an audio program signal which can be turned on and off with a toggle switch. When the switch is on, attenuation is zero. When off, attenuation is infinite. If we satisfy Dr. Nyquist's axiom and toggle this switch at a rate at least twice that of the highest audio frequency, linear signal attenuation becomes directly proportional to the OFF time as depicted in the chart at the top of the next page.

The *DAVID-III* sampling rate is 152kHz, about ten times the highest program audio frequency. Since this is well above the Nyquist rate, anti-aliasing and reconstruction filters can be simple and gentle.

PWM GAIN CONTROL ACTION		
Switch ON	Switch OFF	Attenuation
100%	0%	0dB
50%	50%	6dB
25%	75%	12dB
10%	90%	20dB
1%	99%	40dB

Feedforward Processing

The Triband Processing section of the *DAVID-III* operates in a *feedforward* mode, rather than using the more traditional *feedback* method. The amplitude of the *input* signal establishes circuit gain to hold the output constant at a 100%-modulation “ceiling” value.

Feedforward limiting necessitates a conversion factor to give one dB of output *attenuation* for each dB that the input signal *increases*. Put into linear (voltage), rather than log (dB) terms, this function is expressed as $x=1/y$. Figure 5 graphs this function. x represents the circuit gain needed to hold the output at a constant 1-volt value, with an input, y , that increases from 1 volt to 10 volts. This technique becomes a bit precarious at small duty cycles (attenuations of 40dB or more), but in the 0 to 30dB range typically required for audio processing, PWM is easily implemented, perfectly predictable, and without sonic coloration.

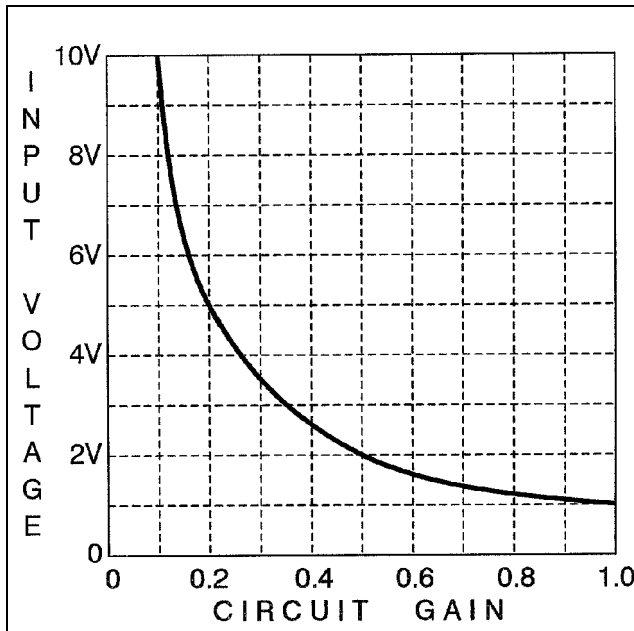

Figure 5
Voltage Transfer Function

Assuming a linear relationship between PWM on/off time and signal gain reduction, the $1/y$ expression translates directly to the duty cycle; that is, 0.1 is a 10% ON time, and 1.0 a 100% ON time.

“Soft Knee”

In the example above, 1 volt represents a *threshold* level, below which gain will remain at full value. In practice, the threshold is adjusted to conform to what has become known as a *soft knee* characteristic. This means that the program signal eases *gently* into

compression and limiting to avoid the abrupt change from a linear to a limited state that characterizes traditional feedback topology. The soft knee is normal behavior for feedforward gain control, and is credited for the smoother, less fatiguing sound attributed to this method.

**The PWM
'Ramp'
Waveform**

Figure 6 shows the waveform that is generated by the *DAVID-III* to affect the desired feedforward transfer characteristic. Note the similarity between this waveform and Figure 5, but with the addition of an extended 'droop' to the right. This droop gives the soft knee compression/limiting threshold. A negative-going 'pedestal' has also been added to keep the CMOS analog switches active, even when no gain reduction is in effect.

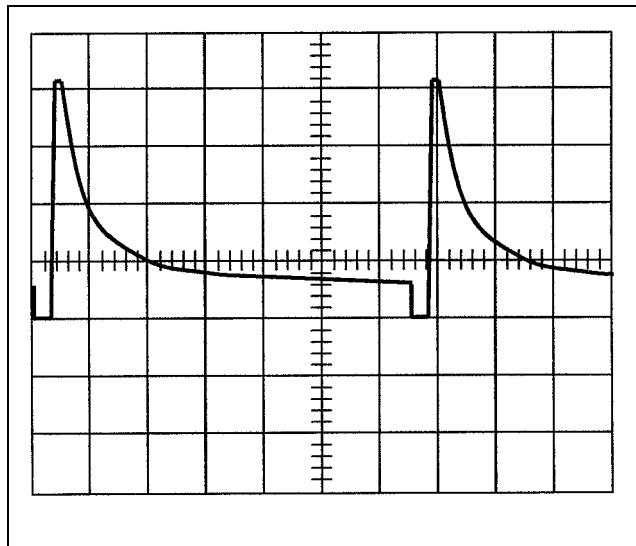

Figure 6
DAVID-III PWM
Ramp Waveform

V=2V/div.
H=1 μ s/div.

This ramp runs continuously at a 152kHz rate. It is applied to one input of a comparator, and a DC voltage derived from the input signal is fed to the other comparator input. The comparator output is the duty-cycle-modulated squarewave that 'chops' the program audio signal.

PWM RAMP CIRCUITS

Master Clock Referring to the Sheet 6 of the Schematic on Page 43, IC3D is the *DAVID-III* master clock running at 1.216MHz, which is 64 times the stereo pilot frequency. IC3C is a buffer, and binary dividers IC21A, IC43A and IC43B derive the 152kHz PWM switching frequency. This is the PROC CLOCK that is picked up on Sheet 3 of the Schematic, Page 40.

**Compressor/
Limiter Ramp** The 152kHz PROC CLOCK is buffered by IC44D. The squarewave differentiated by C107 and R302 creates a 200 nanosecond pulse at the output of IC44C. The positive-going edge of the pulse turns on Q25, which brute-forces the 'pedestal' portion of the PWM ramp waveform.

The negative-going edge of the 200ns pulse is inverted by IC44A and differentiated by C93 and R267. The output of IC44B is a 100ns negative pulse that turns on Q24 to charge C95 instantaneously to about +6 volts.

C95 has a complex discharge path calculated to create the precise PWM reference ramp waveform. The initial fast discharge is through R272 and diodes CR44, CR45 and CR46. After an initial discharge period, CR46 is biased out of the equation and discharge continues through R273. When the voltage level falls below the turn-on point of CR44 and CR45, the remaining discharge path is through R271. The action just described produces the ramp waveform of Figure 6, which is repetitive at the 152kHz rate. The ramp is presented to one input of the three comparators that create the PWM switching squarewave.

AGC Ramp The 200ns negative-going pulse from IC44A, labeled AGC CLOCK, may also be picked up on Sheet 1 of the Schematic, Page 38. This pulse turns on Q26 to charge C109. This capacitor discharges through R304 and R305 to create a separate, second ramp waveform for the AGC stage. This discharge shape is a simple R/C function. As the AGC stage works in a *feedback* mode, the R/C ramp gives a constant dB-per-second control rate over the 30dB AGC range.

SIGNAL PATH CIRCUITRY

NOTE: Left and right program channel circuits are identical, so only the left channel will be described in detail. A skilled technical professional should be able to extrapolate the circuit descriptions for the right channel.

INPUT STAGES

Line Input Balancing Leafing to Page 38, IC48B is the program line input balancing amplifier. JP2 and JP3 short-circuit resistors R358 and R359, respectively, to give IC48B additional gain for low-level program inputs.

INPUT LEVEL Control A single multiturn potentiometer, R326, sets the *DAVID-III* input sensitivity for both stereo channels. IC54B and IC55A include both positive and negative feedback to create constant-current sources for the left- and right-channel program signals feeding the two ends of R326.

Despite appearances, INPUT GAIN control R326 does not operate as an arm of a voltage divider. Constant-current feeds to the two ends of this pot makes its attenuation of the program signal directly proportional to the resistance to the grounded wiper. This means that as the left channel signal decreases, the right channel level increases, and vice-versa. But the backward-level-controlled right channel program is combined out-of-phase with the 'raw' right

channel input by IC54A, causing the right channel to track the left channel output of IC54B. Many thanks to W. Stephen Woodward and *Electronic Design* magazine's *Ideas* section for this clever one!

AGC Stages

The AGC amplifier is made up of two identical cascaded stages. IC53B and IC51B are configured as second-order, low-pass filters with gain. There is a CMOS analog switch at the input of each stage, part of the 4-section IC52. The duty cycle, or on-versus-off time, of this switch determines the gain of the circuit as tabulated at the top of Page 19.

The AGC output is inverted by IC50B to afford full-wave rectification by CR56 and CR57. The cathodes of these diodes are common to those in the right channel to make AGC action dependent on the greater of the two channels, thus preserving the stereo image.

The rectified AGC output is integrated by R277 and C96, the output of IC45B representing the *average value* of the program signal. This derived DC voltage is identified as PGM AVG and is also employed in the pre-emphasis stages.

IC45C compares the average program level with a DC reference from the R310/R311 divider. When the program level exceeds the reference, the output of IC45 goes high, charging C97 through R298 and R299. When the program level is below the reference, CR51 is reverse-biased and C97 discharges through R299 and R297.

Integration by R299 and C97 determine the AGC correction rate. DC buffered by IC45D is presented to one input of a comparator comprised of Q27, Q28 and Q29. The AGC ramp is fed to the other comparator input, and the output from Q29 is the PWM control for the four IC52 analog switch sections.

AGC Gating

AGC in the *DAVID-III* is 'gated,' meaning that gain does not slowly increase out of proportion when no valid input signal is present.

R356 and R357 sum the left and right channels into IC46A. This stage is also a first-order band-pass filter that favors voice frequencies and desensitizes the gating circuit to air-conditioner rumble and squeaky chairs. The L/R sum is full-wave rectified by CR49, CR50 and IC46D. A short time constant of this rectifier is set by R313, R314, C110 and C111.

When the input is low, below the gating threshold, the output of IC46D goes positive. CR53 biases the DC reference for the AGC out of the picture, and CR52 sets a fixed DC bias through R309, R298 and R297 that corresponds to the AGC 0dB 'resting point.' Thus when there's a pause in the program, AGC gain slowly returns to 'zero.' When the program is active, the output of IC46D goes negative. This lights the GATE OPEN indicator, reverse-biases CR52 and CR53, and enables normal AGC action.

- AGC Metering** Six op-amp sections monitor the output of IC45D and drive the seven front-panel A.G.C. GAIN indicators. Each op-amp section has gain and fixed-bias values to ensure that the seven A.G.C. GAIN LEDs fade evenly over the 5dB indicated steps of gain.
- Pre-Emphasis** Jumping down to Page 39, IC49B has integration in its feedback path to effect proper program pre-emphasis. Jumper strip JP6 selects either the 75 μ s or the 50 μ s characteristic. Pre-emphasis selection is described on Page 9.
- Program Pre-Clipping** The feedback path of IC49B also includes transistors Q32 and Q33. These serve as hard clippers for program signal peaks, the clipping point determined by DC bias applied to the transistor bases.
- Program pre-clipping is keyed to the *average* value of the program signal. This L+R program average value is derived from the output of the AGC amplifier by IC45B. Time constants of R277 and C96 are relatively quick, so the PGM AVG voltage closely follows the envelope of the L+R program signal.
- The gain of IC45B maintains the PGM AVG *DC voltage* level at a point 10dB to 12dB above the actual *program audio* level at the output of IC49B. This means that when program dynamics exceed an average-to-peak ratio typical of music and speech, program peaks are hard-clipped.
- The effect of clipping at this point is seldom ever audible. In the first place, sadly few CD music tracks contain peaks more than 10dB above the true-average level of the music. Secondly, clipping is in the pre-emphasized domain. This means that clipping artifacts are attenuated by receiver de-emphasis. Finally, the program-derived DC value is a *simple* average and not based on an *r.m.s.* average of the program signal. Repetitive peaks add to the average value further to help bias the clippers out of the program.
- For the most part, only transient, non-repetitive program peaks are ‘pre-clipped.’ Nonetheless, this action is quite effective in reducing unnecessary Triband Processing action.

TRIBAND PROCESSING

- Band Division** The *DAVID-III* works on the program audio signal in three frequency bands. These are nominally BASS, MASTER (midband) and BRILLIANCE. A graphic representation of band-splitting is shown in Figure 7 on the next page.

Band division is obviously asymmetric. The three bands certainly don’t look as though they would recombine properly to give flat overall response, but they do. Here’s why.

IC35A is a second-order low-pass filter with rolloff beginning at about 100Hz. The output of this stage is the bass band. This output is *subtracted* from the program input by IC36A, which also has a second-order low-pass function starting at about 4kHz. The output of IC36A has the midband band-pass response shown in

Figure 7, including the 1dB 'hump' at 175Hz. Note that the high-pass characteristic of the midband is only first-order, even though it was derived from a second-order subtraction. But wait, that's not all!

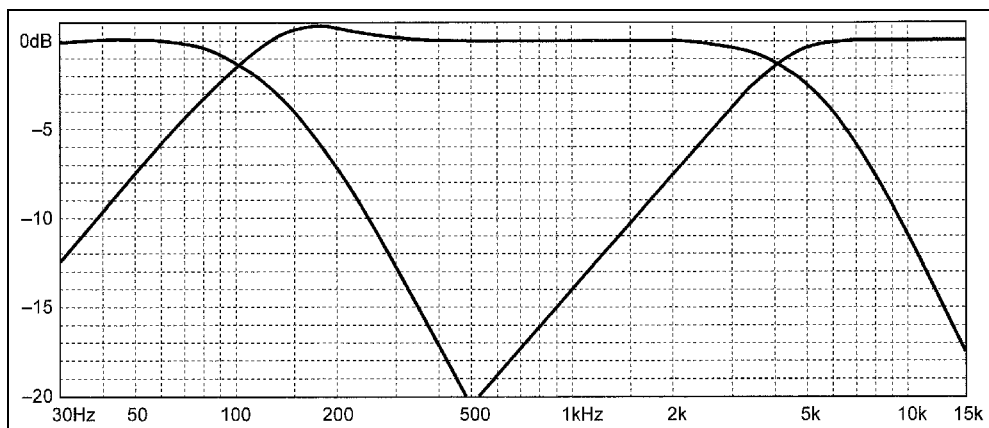

Figure 7 - DAVID-III Triband Frequency Division

IC37A is yet a third subtraction stage. It subtracts both the midband and the BASS band from the program input, and its output is the brilliance band.

Now, as all three of the frequency bands were derived by *subtraction* from the full-range program signal, there is no way that they *can't* add back up to flat response... and they certainly do. Moreover, not only is the recombined *amplitude* response as flat as the proverbial pancake, but the *phase* response is linear as well. Even as the gain of a particular band is changed through Triband Processing action, this circuit architecture is distinctly free of 'phase funnies' and amplitude peaks at the crossover frequencies.

Band Rectifiers

Each of the three band-splitting stages has a companion phase inverter to provide full-wave rectification of each band output. DC control voltages from each band are common to both the left and the right channels to preserve stereo imaging. The DC control voltages are identified in the schematic as BASS RECT, MSTR RECT and BRILL RECT.

Midband Time Constants

Flipping over to Page 40, C55 charges to the instantaneous peak value of the midband program signal through R202. This peak-derived DC is fed directly to the PWM comparator, Q17, Q16 and Q15. The ramp waveform of Figure 6 is presented to the other input of the comparator. The output of the comparator is a squarewave, labeled MSTR PWM on the schematic. The duty cycle of this squarewave is inversely proportional to the gain reduction needed to maintain midband program level at a constant value. This describes the feedforward gain control action.

C55 discharges through R162 into C54, and both capacitors discharge through R164 to ground. The purpose of C54 is to provide a release 'platform,' which is defined as: 1) a secondary level to which fast peak reduction can release quickly, and: 2) a level representing the *average value* of gain reduction that can release

more slowly. This dual time constant separates the *peak-limiting* and *average-compression* functions of *DAVID-III* processing.

C55 is never allowed to discharge completely to ground, however. R174 and R175 provide a fixed bias, which is delivered to C55 through CR30. This bias maintains about 9dB of gain reduction in the midband section at all times, an essential requirement of the Spectral Loading feature.

The MASTER DRIVE control also factors into the equation. At full counterclockwise (0dB) an additional amount of fixed DC bias is fed to C55 through CR26 and R161; about another 12dB worth of gain reduction, in fact. This serves to further reduce midband and, as we shall see, overall gain through the system. This 'gain spoiling' is about equal to the average-to-peak ratio established by the pre-clipper ahead of the Triband Processing section. This means that at the 0dB setting the average-responding AGC is largely responsible for overall program signal leveling. Expected program peaks 10dB to 12dB above the average program level will *just* drive transmitter modulation to 100%. With the MASTER DRIVE pot at 0dB, there will be very little if any processing of the incoming program aside from gain-riding AGC.

As MASTER DRIVE is rotated clockwise, less and less of the gain-spoiling voltage is applied to C55. As a result, program peaks become more and more subject to processing in this section. When MASTER DRIVE is at +12, only the 'quiescent' 10dB worth of gain spoiling from R174 is in effect, and processing is at maximum, so far as *levels* are concerned.

As MASTER DRIVE is turned further clockwise, from +12 to MAX, something else happens. The wiper of R183 begins to go negative because of bias through R181. This has two effects. First, the quiescent gain-spoiling voltage through R174 is reduced somewhat, which has the effect of further increasing midband processing. Secondly, the midband gain-reduction release platform developed by the charge on C54 is eliminated because of negative bias through CR27 and R163. This causes a fast release over the *entire* midband gain-reduction range, which gives an apparent loudness increase with some types of programming, but at the risk of some material sounding 'choppy.'

Midband gain-reduction voltage is integrated by R165 and C57. The voltage across C57 represents the long-term average of gain reduction in effect. This voltage is buffered by IC34A, which has about a 3dB DC gain. This voltage, 'G/R+3dB,' is connected to the top of the BASS and BRILLIANCE adjustments.

Bass Processing

C65 integrates the DC peak value of the rectified bass channel input (BASS RECT), though integration is not instantaneous because of series resistor R213. This resistor does not have the expected effect of slowing down the bass limiter attack time, as the rectified input is fed directly to the bass band PWM comparator, Q23, Q22 and Q21. The charging of C65 is delayed, to be sure, which causes 'self-modulation' for the first few cycles of the bass waveform. This

imparts a delightfully ‘gutsy’ quality to the attack of bass instruments, making the bass sound ‘phatter.’

BASS control, R142, delivers variable amounts of ‘gain-spoiling’ DC bias to the gain-reduction circuitry. When set at -3 , an amount of DC equal to average midband gain reduction, plus an additional 3dB due to gain in IC34A, becomes the reference for bass band gain-reduction release. Bass peaks exceeding midband program energy will be limited independently, but gain in the bass band will be spoiled by the additional 3dB even at full release.

Set at 0dB, the wiper of R142 is at the same DC level as average midband gain reduction. Bass peaks are independently limited as required, but this section releases back only to the midband average release level. At this setting the bass band is coupled, or ‘slaved,’ to midband gain reduction.

As BASS is turned progressively clockwise, the bass band is allowed to release to a DC resting point that is actually *lower* than the release point of the midband section. This brings Spectral Loading into play, which increases the overall *energy* in the bass band. As the midband has a full-release level that is ‘spoiled’ by 9dB, program bass can actually be enhanced by this same figure at full clockwise rotation of the BASS control.

Primary bass band release is through R203, and is realized when the BASS control is at $+9$. As gain-spoiling bias is introduced through CR25, release slows down.

Brilliance Processing

Because the brilliance band involves frequencies of 4kHz and up, gain control action can afford to be very fast. Attack is near instantaneous as C75 charges through R208. The integrated DC is applied directly to PWM comparator Q20, Q19 and Q18.

Spectral Loading for the brilliance band is identical to that described above for the bass band. The only difference is R214 inserted in the clockwise leg of BRILLIANCE control R243. This limits the amount of Spectral Loading to +6dB for the top end of the audio spectrum, a figure in keeping with restraints imposed by FM transmission system pre-emphasis.

PWM Comparators

Why in the world would anyone build a comparator from discrete transistors instead of using an integrated circuit? For a couple of reasons, actually. Most fast comparator ICs do not have sufficient input dynamic range for *DAVID-III* applications; many have a pathetic 5-volt restriction on the differential input range. Comparators that have sufficient differential and common-mode specifications aren’t fast enough, and those that are speedy tend to oscillate if you look at them wrong. Finally, three transistors cost a fraction of what the one or two, single-sourced ICs cost that we could have used in these spots.

Gain Reduction Indicators

G/R (gain-reduction) indicators utilize a simple differential amplifier driving a pair of LEDs. In each of the three bands, the DC control voltage is fed to one input of the differential amp and the compressor/limiter release level is fed to the other. Gain and offset of the

stages is such that the green LED glows at full brightness with no reduction in effect, fading to full-brightness of the red LED with 12dB of reduction. Midway through the display range, both LEDs should be lit about halfway.

Combining Amplifier

Back on Page 39, IC33B is a current-summing combining amplifier and low-pass filter. The three frequency bands are summed through resistors R235, R234 and R233, with a CMOS analog switch sections in series with each.

Gain-control PWM drives the analog switches, the duty cycle effectively multiplying the 3k series resistor. When the duty cycle is 50% in the bass band, R235 looks like 6k. At 10%, the effective resistance is 30k. The current-summing configuration of IC33B eliminates interaction between the bands, and the low-pass response removes the 152kHz switching frequency.

THE PIPP* LIMITER

The operating theory of the PIPP* Limiter is detailed on Page 16. Though the subject US Patent covers various analog and digital implementations of the fundamental concept, the configuration used in the *DAVID-III* is absurdly simple.

On Page 41, the program audio signal from the Triband Processor section is routed to IC32B through R199 and R198. C68 and C69 turn this stage into a unity-gain low-pass filter.

The bases of Q11 and Q12 are connected to the junction of R199 and R198. The emitters of these transistors are clamped at DC levels representing the absolute output ceiling of the *DAVID-III*. Thus Q11 and Q12 will always serve as hard clippers for program peaks that exceed the assigned ceiling value. But each of these two transistors is part of a voltage amplifier as well.

Using the Q12 side of the circuit for an illustration, as the program signal approaches the final clipping point Q12 begins to conduct, which turns on Q14 to begin charging C40. Voltage developed at the top of C40 turns on Q5, which is connected to the program signal path through R102 and CR18. As Q5 conducts, positive waveform excursions are maintained at the clipping threshold, which becomes the final-limiting point. This action describes a closed-loop, feedback peak limiter for positive program peaks. CR18 ensures that this part of the circuit has no effect over the negative-going program components.

The emitter of Q5 is biased to a DC level that cancels the forward drop of CR18 and the saturation voltage of Q5. A small amount of program signal current is applied to the base of Q5 to linearize the transistor's dynamic conduction resistance over the range of the collector voltage swing.

Q11, Q13 and Q6 serve the same function for negative program peaks. Control voltage for the positive and negative limiters is summed by IC27D, which, with the help of its companion inverter, drives a bi-color LED to indicate PIPP* Limiter action.

When the PIPP* Limiter is turned off by S3, R103 is switched into the circuit. This attenuates the program signal by an amount equal to the typical value of PIPP* Limiter gain reduction so that the incoming program signal will not be clipped excessively by Q12 and Q11 when the PIPP* circuit is *not* enabled.

LOW-PASS FILTER

Filter Overshoots All low-pass filters exhibit a certain amount of overshoot and ringing when presented with complex input waveforms. Generally, the sharper the cutoff, the more pronounced the effect. Overshoots result from the elimination of higher-order input signal components. Prior to filtering, these components helped to define the signal peak amplitude. Even a fully phase-corrected filter will exhibit overshoots, and the 7-pole “elliptic” filter used in the *DAVID-III* can overshoot 3dB or more!

Other systems of overshoot control permit the primary low-pass filter to overshoot, then isolate and re-introduce the overshoots to cancel themselves in the signal path. The patented overshoot compensator in the *DAVID-III*, on the other hand, pre-conditions the limited program signal *ahead* of the filter so that there is little tendency for the filter to *generate* overshoots.

Overshoot Compensation

Thumbing to Page 42, IC31B includes a phase-lag network that displaces the fast leading and trailing edges of steep waveforms in time. This means that the primary *time-domain* characteristic of a program waveform that would normally excite filter overshoots is instead added to the waveform *amplitude*. CR29 and CR28 are biased to the limited/clipped level of the input program signal and “strip” these displaced-and-added components from the phase-lagged program waveform. IC29B is a differential stage that compares the input and output of the ‘stripper’ to recover the stripped-off components. As these components contain much of the program harmonic (high frequency) information, we cannot afford simply to throw them away. By recombining these stripped-off program components *out of phase* with the stripped program signal, the spectral integrity of the program is maintained. This 180-degree displacement of certain program overtones is not discernible to the listener, but is most effective in inhibiting filter overshoots.

The Low-Pass Filter

The 7-pole, elliptic-function (Cauer) low-pass filter is an active version of the classic L-C designs worked-out in Germany during the late 1940s (probably with a slide rule!). The particular active configuration used in the *DAVID-III* is sometimes called the “FDNR” because each of the legs to ground simulates a Frequency-Dependent Negative Resistance. Referring back to the classic L-C

design, resistors in series with the signal replace series inductors, and each of the active circuits to ground replaces an inductor/capacitor series-resonant element.

Components in the left channel filter have fixed values. The resonant frequency of each of the right channel legs is variable over a small range so that the two channels may be precisely matched in amplitude and phase response.

A great cookbook with this and other filter circuits that might prove valuable to the broadcaster is the *Electronic Filter Design Handbook* by Arthur B. Williams, published by McGraw-Hill. The reader is kindly directed to this source for a more informed discussion of how the FDNR circuit works than we could possibly muddle-through here.

IC14B buffers the output of the low-pass filter and includes gain, both to compensate for the 6dB filter loss and to present the proper amplitude to the digital synthesis circuitry.

PILOT AND SUBCARRIER SYNTHESIS

Clock Turn, if you will please, to the last sheet of the Schematic on Page 43. As previously described in the PWM discussion, IC3D is a crystal-controlled oscillator at 1.216Mhz. IC3C buffers the clock, and IC21A, the first binary divider, furnishes the 608kHz digital synthesis sampling frequency.

Pilot Generation IC10 is an up/down BCD counter clocked at the 608kHz sampling frequency. 1-of-10 decoder IC9, OR gate IC8B, and binary divider IC7A work together to keep IC10 continually counting from zero to 8, back down to zero, etc. Counting logic is decoded by a 1-of-9 demultiplexer (IC18 and IC20A) that samples a resistor string with sine-weighted values. This generates *one-half* a sinewave for each counting cycle. IC21B reverses the DC polarity applied to the top of the resistor string for *every-other* up/down count, forming the complete 19kHz pilot sinewave from 32 discrete steps. R68 introduces an offset to compensate for any difference between the power supply rails. This is adjusted to null the 38kHz second harmonic component. The segmented Stereo Pilot is buffered by IC17B.

'Center Sampling' Analog switch IC20C is controlled directly by the 1.216MHz clock. It turns on for one-half of one clock cycle precisely at the *center* of each stepped pilot waveform sample. This charges C27 to the sample voltage value, which is held by buffer stage IC17A until the next center sample is taken. Center sampling eliminates integration of switching noise that is concurrent with leading and trailing edges of the waveform steps.

Subcarrier Generation The FM-multiplex waveform consists of a 'main' channel, conveying the L+R stereo sum in its normal audible frequency range, and a 'sub' channel with L-R stereo difference information in the form of

a 38kHz double-sideband, suppressed-carrier subcarrier. The 19kHz pilot is added to enable stereo receivers to reconstruct and reintroduce the 38kHz carrier for difference signal demodulation.

Digital synthesis of the composite waveform is similar to the generation of the stereo pilot previously discussed, but with sinusoidal *commutation* between the left and the right stereo program channels at a 38kHz rate.

Up/down counter IC6 is clocked at the 608kHz sampling rate. The output is decoded by IC5 and, with gating provided by IC8D, CR11, and IC7B, IC6 counts continuously from zero to 8, back to zero, etc. A Pulse from IC8A presets the counter to its center position (count of 4) each time the pilot reaches the proper phase relationship. This ensures proper and constant synchronization between pilot and subcarrier.

IC15 and IC20D also decode the count, sequentially sampling each tap of the resistor divider string which bridges the left and right program audio signals. Sampled program audio is buffered by IC16B, center-sampled by IC20B, and held between samples by C26 and buffer IC18A. The stereo multiplex signal consists of 16 discrete, sine-value-weighted steps.

When the front-panel MODE switch, S2, is set to MONO, the counting sequence is halted with the counter preset at the center position (count of 4). This stops the subcarrier generation, and L+R audio appears at the *DAVID-III* output. S2 also stops the stereo pilot in the MONO mode.

Composite Clipper

Diodes CR12 and CR13 are biased to the same 100%-modulation level established by the PIPP* Limiter and overshoot compensation circuits. The buffered composite signal, less the stereo pilot, is presented to this clipper through front-panel COMP. CLIPPING control R36. When R36 is set to its fully counterclockwise position (OUT), the two diodes catch only the occasional program peak, which somehow has eluded the earlier processing and clipping stages. As R36 is cautiously turned clockwise, program peaks at the 100%-modulation value may be subjected to as much as 3dB clipping.

Even though the composite waveform is clipped prior to pilot injection, good broadcasting practice demands judicious use of this feature. (See Page 17.)

Combining Amplifier

IC11B is a combining stage for the main/sub portion of the composite signal and for the 19kHz stereo pilot. The front-panel MPX LEVEL control, R41, is in the feedback path of IC11B, affording adjustment over the composite level delivered to the exciter.

Output Filter

Since all components of the composite output are digitally synthesized at a 608kHz rate, only a simple filter is required to eliminate the sampling frequency from the *DAVID-III* output. L2, L1, C21 and C20 form a 4-pole filter with quasi-Butterworth response. This filter is exceptionally flat to about 100kHz, but effectively attenuates higher-order digital noise components in the *DAVID-III* output.

**Output
Phase and
Equalization
Trimmers**

The output amplifier consists of IC11A, IC4B, and transistors Q1 and Q2. R19 affords variable high frequency tip-up, and R13 varies the phase response. These two controls are factory-adjusted to optimize stereo separation.

POWER SUPPLY

DAVID-III circuitry operates from the bipolar 9-volt supply diagrammed on Page 42. The two supplies are regulated by linear “three-terminal” IC voltage regulators: IC1 for the +9-volt supply, IC2 for the -9-volt supply. The power transformer has dual primary windings that may be switched in parallel or in series for 115V or 230V mains, respectively.

YOUR NOTES AND DOODLES...

...are welcome here and on the following page.

Section V

APPENDIX

This section of the *DAVID-III* Manual contains Parts Listings, Schematic Diagrams and an explanation of Inovonics' Generous and Liberal Warranty Policy.

PARTS LIST

EXPLANATION OF PARTS LISTINGS

This section contains listings of component parts used in the Inovonics *DAVID-III*. Not all components are listed by schematic reference designation; those that are considered 'generic' may have qualification notations, however.

Descriptions may or may not specify a particular manufacturer. When no manufacturer is called out, the term (open) advises that any manufacturer's product carrying the given part number (or the same description in the case of a generic part) is acceptable.

If a part is not listed at all, this means that we do not consider it a typical replacement item. Should you need to order an unlisted part, call, write, fax or e-mail the factory with a brief description of what it is that you need. We'll then do our very best to figure out what to send you.

Components with reference designations below 500 are contained on the main printed circuit board, and those in the 600s are chassis-mounted components.

PARTS LISTINGS

Unless specifically noted by component reference designation, **capacitors** are specified as follows:

- a: Under 100pF** are general-purpose disc ceramic capacitors with no specific technical specification. The letter 'p' following the value indicates picofarads.
- b: 100pF to 0.47μF** are of the metallized Mylar or polyester variety. Whole number (XXp) values are picofarads, decimal values are microfarads. All capacitors in this category have 5% tolerance and are rated at 50VDC or better. The style used in the *DAVID-III* is the "minibox" package with lead spacing of 0.2 inch. The preferred manufacturer is WIMA, their FKS-2 or MKS-2 series. Possible alternates are the CSF-Thompson IRD series or the Vishay-Roederstein KE-1808 or KT-1817 series.
- c: 1.0μF and above** are general-purpose aluminum electrolytics with radial leads. A safe voltage rating for any electrolytic in the *DAVID-III* would be 25V, but because of size and other considerations a replacement capacitor should always carry the same rating as the one being replaced.

C1,2	Capacitor, Y-class Ceramic Disc, .0047 μ F, 440VAC; Murata/Erie DE7150 F 472M VA1-KC
C5	Capacitor, Variable, 5-50pF; Mouser 24AA024
C8,9	Capacitor, Electrolytic, axial leads, 1000uF, 35V; (open)
C14-16,28,29,31-35, 41-44,50,51,60,61, 70,71,81,91	Capacitor, “High-Q” Polypropylene, 0.0033 μ F, 2.5%, 100VDC; WIMA MKP-2 series
C114,130	Capacitor, Non-Polar Electrolytic, 22 μ F, 25V; (open)
CR1-6	Diode, Silicon Rectifier; (open) 1N4005
CR7-57	Diode, Silicon Signal; (open) 1N4151
F1	Fuseholder; Littlefuse 0286067 (The fuse itself is a 5mm normal “fast blow” type; the value should match the specification stated on the rear panel.)
FB1	Ferrite Bead; Amidon 73-801
I1	T1 Red LED; Kingbright L934ID
I2,19	T1 Green LED; Kingbright L934GD
I3	T1 Yellow LED; Kingbright L934YD
I4,5	T1 $\frac{3}{4}$ Bi-Color LED; Mouser 512-MV5437
I6,8,10,12,18	T1 $\frac{3}{4}$ Red LED; Kingbright L53ID
I7,9,11,14,15,16	T1 $\frac{3}{4}$ Green LED; Kingbright L53GD
I13,17	T1 $\frac{3}{4}$ Yellow LED; Kingbright L53YD
IC1	Integrated Cct.; (open) LM317-T
IC2	Integrated Cct.; (open) LM337-T
IC3,44	Integrated Cct.; (open) CD4011
IC4,12,13,14,16, 17,22-25,28-33, 35-40,48-55	Integrated Cct.; (open) LF353N
IC5,9	Integrated Cct.; (open) CD4028B
IC8	Integrated Cct.; (open) CD4071B
IC15,18	Integrated Cct.; (open) CD4051B
IC19	Integrated Cct.; (open) CD4081B
IC26,41,52	Integrated Cct., (open) CD4066B
IC27,34,45,46	Integrated Cct.; (open) LM324N
J1	Connector, AC Mains; Switchcraft EAC303
J2,3	Connector, XLR Female; Mouser 568-NC3FAH-0
J501	Connector, BNC chassis-mounting male; Mouser 523-31-221-75RFX
JMP1-6	Shorting “Shunt” for 0.1-inch header strips; (open)
L1	Inductor, 560 μ H Molded; Inductors, Inc. CTS3-561J
L2	Inductor, 220 μ H Molded; Inductors, Inc. CTS2-221K
Q1	Transistor, NPN; (open) MJE340
Q2	Transistor, PNP; (open) MJE350

Q3,5,8,9,12, 13,25,30,33	Transistor, NPN; (open) 2N3904
Q4,6,7,10,11,14,15,18, 21,24,26,29,31,32	Transistor, PNP; (open) 2N3906
Q16,17,19,20,22, 23,27,28	Transistor, NPN; (open) 2N5088

Except as noted by reference designation, **all resistors** used in the *DAVID-III* are the value specified on the schematic, qualified per the following:

- a: Fixed Resistors** with values carried to decimal places implying a 1% tolerance (*example: 232, 3.01K, 10.0K, 301K*) are ¼-watt, 1% metal film type.
- b: Fixed Resistors** with values typical of a 5% tolerance (*example: 220, 3.3K, 10K, 270K*) are ¼-watt, 5% carbon film type.
- c: Single-Turn Trimming Potentiometers** (circuit board) are Tocos GF063U1 series.
- d: Multi-Turn Trimming Potentiometers** (front-panel adjustable) are Tocos RJC097P series, or equivalent ‘cermet’ types.

R36,142,183,243	Potentiometer, 10K; Piher PT10MH01-103A2020 with Figure 15 spindle. <i>Inovonics P/N 0580</i>
S1	Switch, Voltage-Selector; ITW 18-000-0022
S2,3	Switch, SPDT Toggle; C&K 7101-M-D9-A-B-E
T1	Transformer, Power; Signal LP 20-600 (or direct cross-ref.)
Y1	Crystal, 1.216MHz; <i>Inovonics P/N 1242</i> .

PARTS SUPPLIERS

Inovonics strives to maintain factory stock of all parts used in the products we manufacture. A large proportion of the components in the *DAVID-III* is ‘generic’ and may be obtained from a wide variety of sources.

A few parts can be more-or-less proprietary. These either may be manufactured specifically for Inovonics or purchased directly from a manufacturer that sells only in production quantities.

Inovonics does not depend on parts sales to fatten our coffers. Nor do we impose a minimum charge for parts. In some cases we will elect to supply ‘nuisance’ parts at no charge, rather than generate the necessary paperwork. Always check with the factory, we may well prove the best source for your replacement component needs.

The electronic component distributors listed below have proven themselves reputable suppliers for small quantities of component parts for broadcasters and for other commercial or professional users.

With all due-diligence, please avoid the temptation to use cross-referenced hobbyist or TV/VCR Repair Shop “direct replacement (*ha!*) parts.”

Nearly any semiconductor, IC, capacitor, resistor or connector used in the *DAVID-III* will be available from one or more of these firms. Each supplier maintains a Website and publishes a full-line printed catalog, which is free for the asking. Minimum-order restrictions may apply, and export orders may prove somewhat problematical.

Mouser Electronics

www.mouser.com — 1(800) 346-6873

Digi-Key Corporation

www.digikey.com — 1-(800) 344-4539

Future-Active Industrial Electronics

www.future-active.com — 1-(800) 655-0006

Allied Electronics

www.alliedelec.com — 1-(800) 433-5700

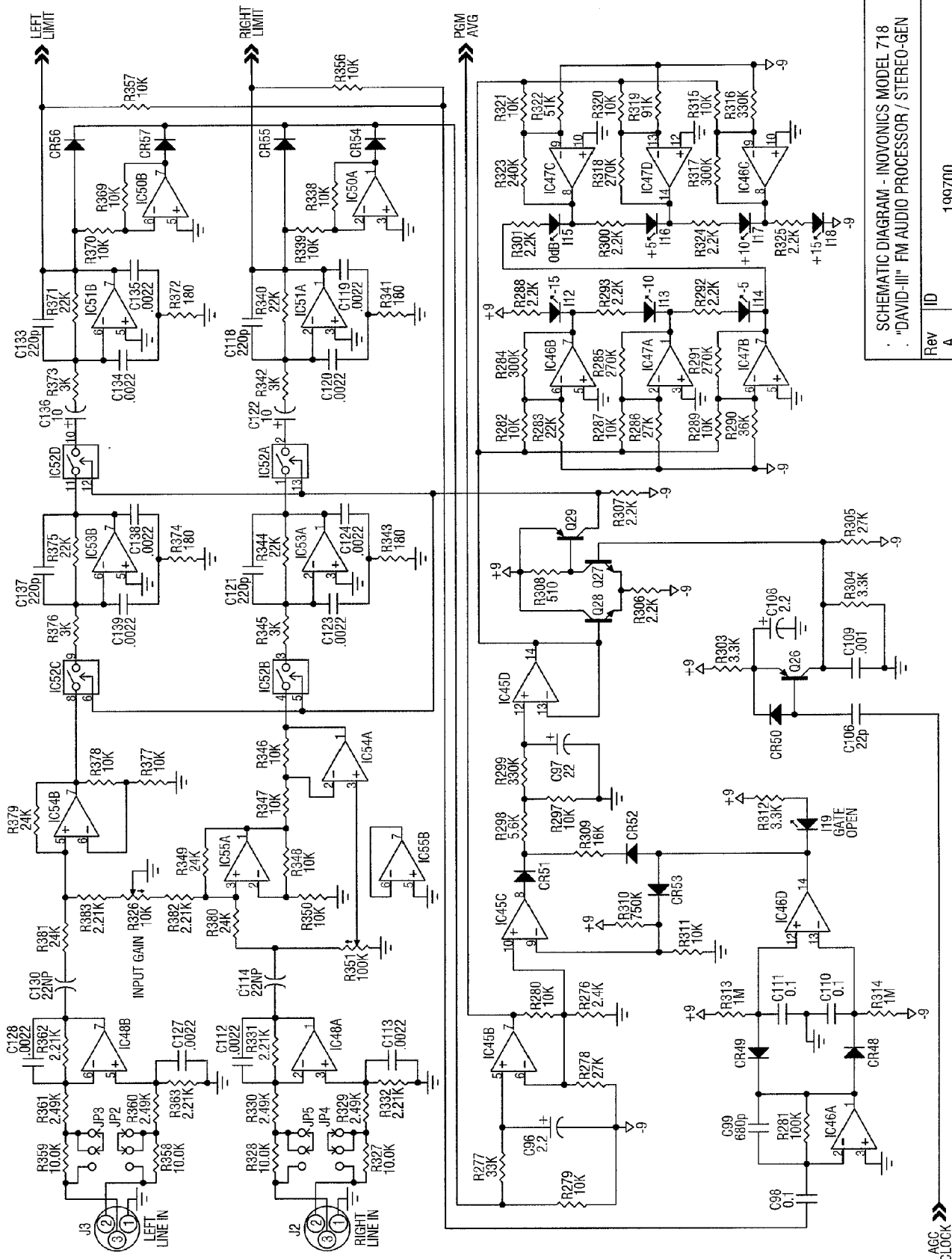

SCHEMATIC DIAGRAM - INOVONICS MODEL 718
 "DAVID-III" FM AUDIO PROCESSOR / STEREO-GEN

Rev	ID	199700
Date:	1 JUNE 2004	Page: 1 of 6

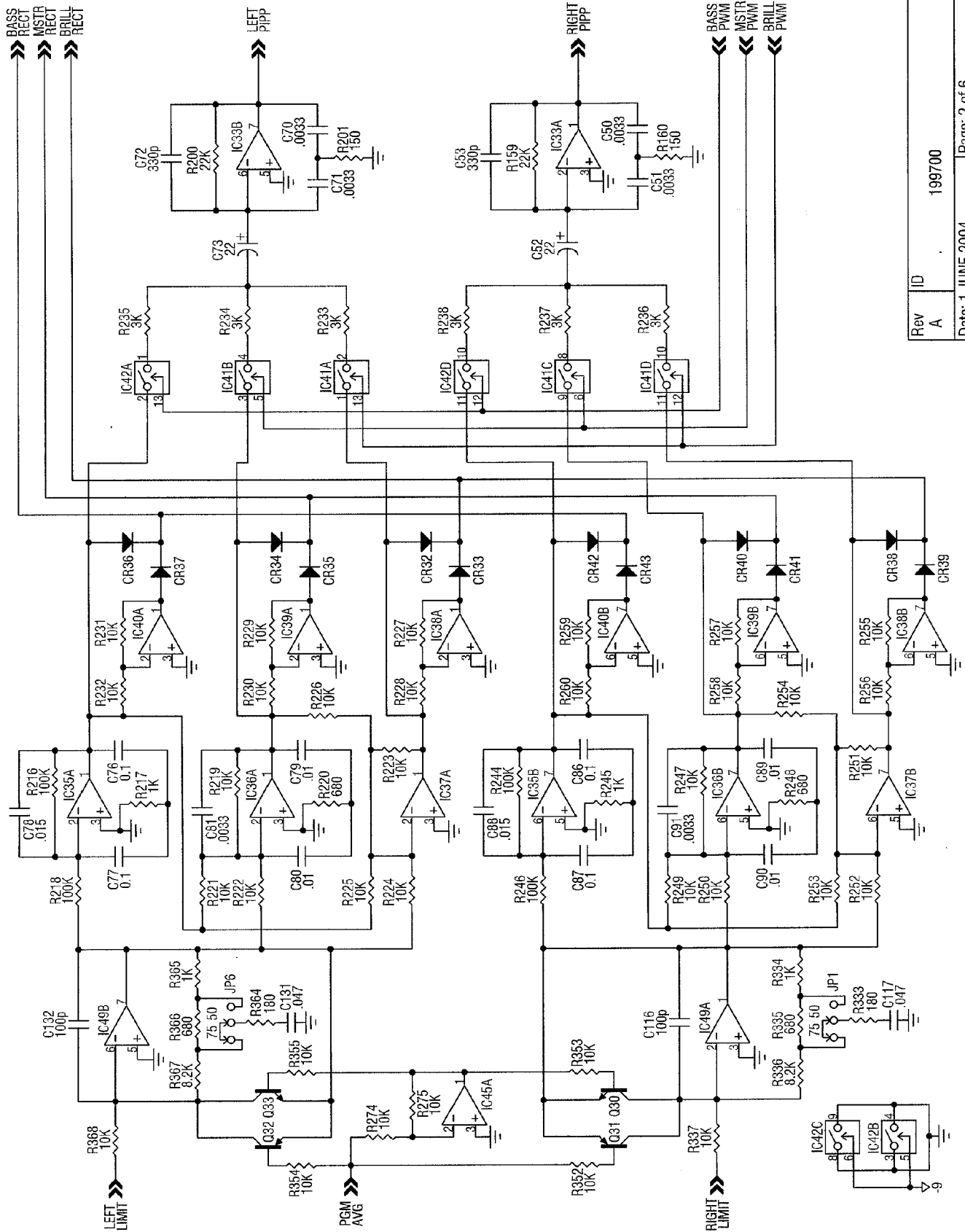

Rev	ID	199700
A		
Date: 1 JUNE 2004		Page: 2 of 6

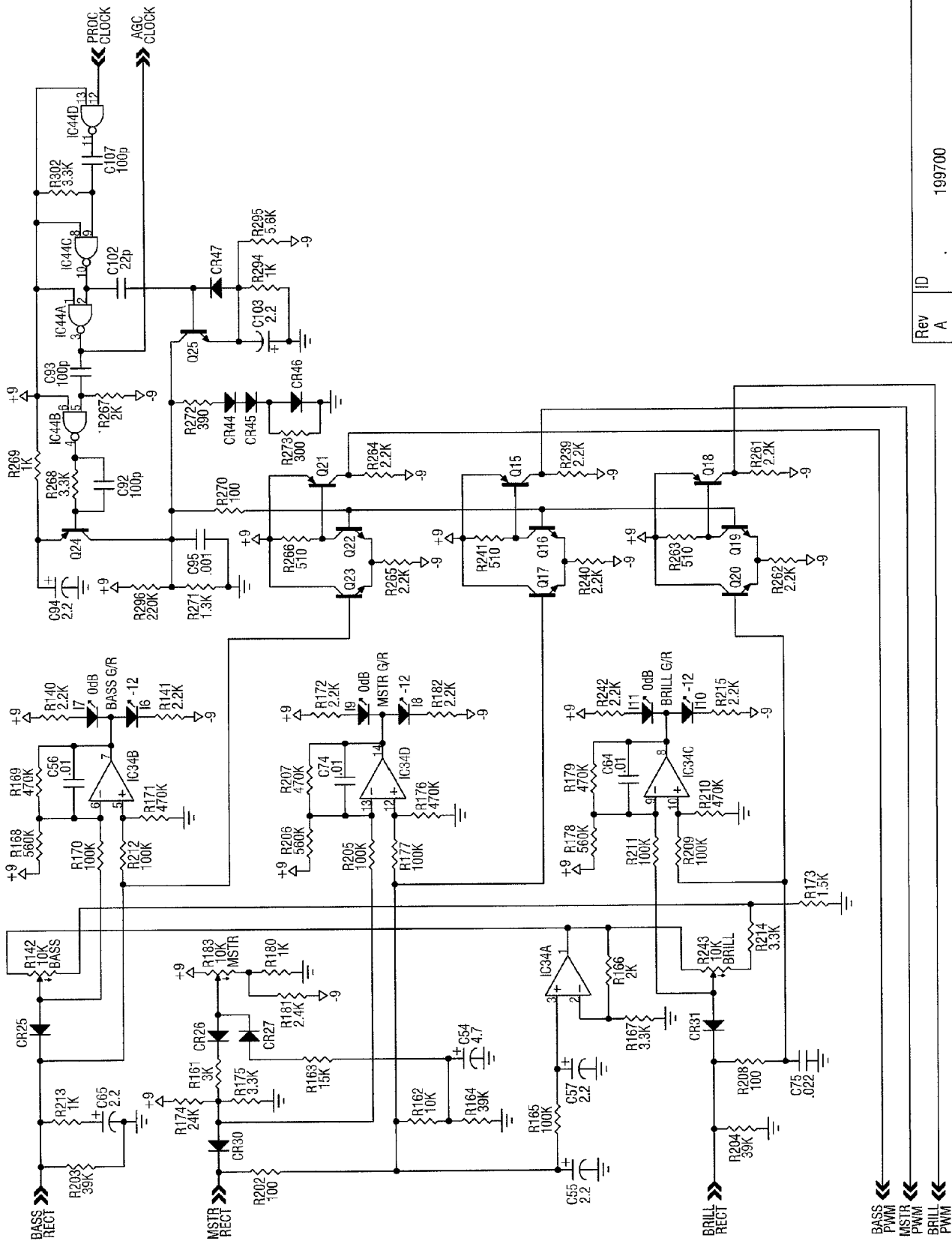

Rev	ID	Date:	1 JUNE 2004
A			
		199700	Page: 3 of 6

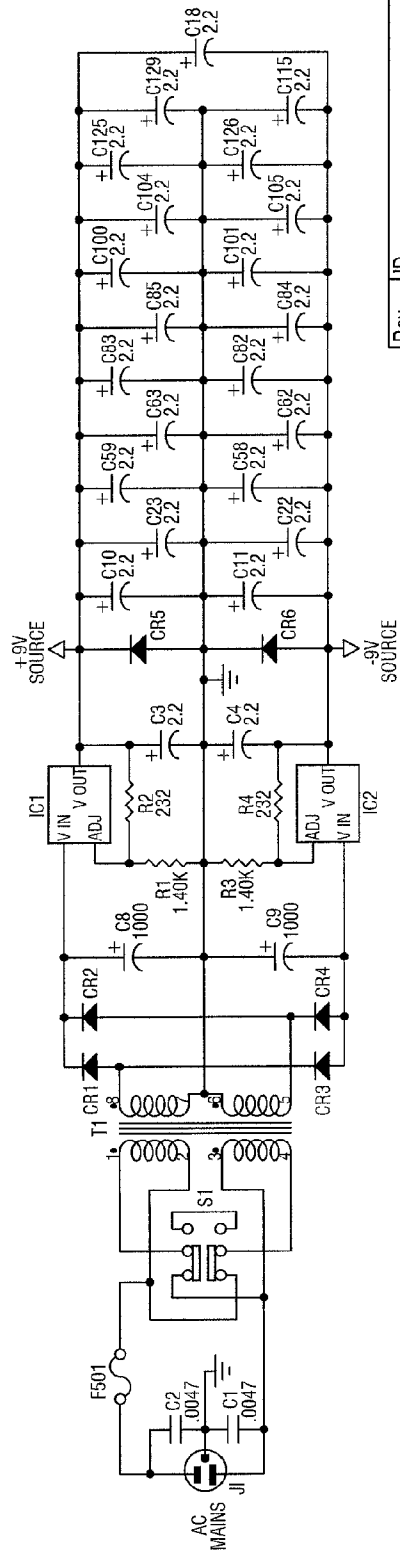
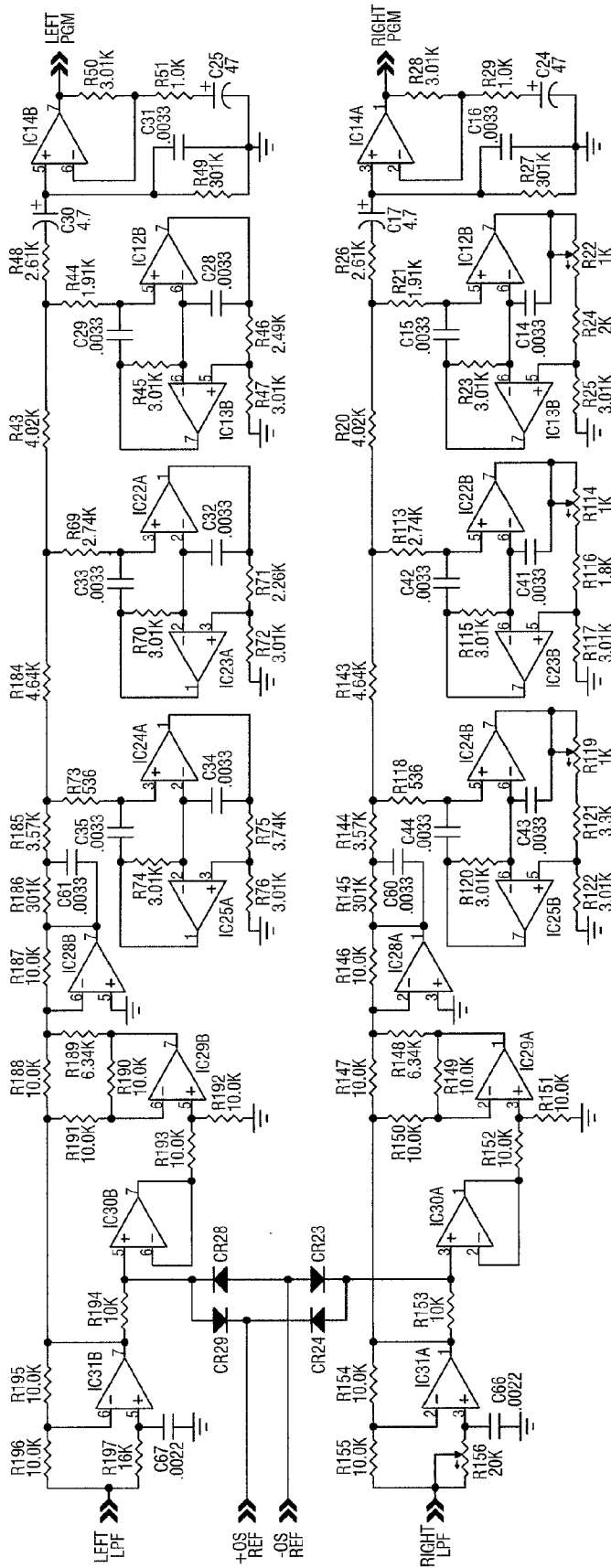

Rev	ID	199700
A		
Date: 1 JUNE 2004		Page: 5 of 6

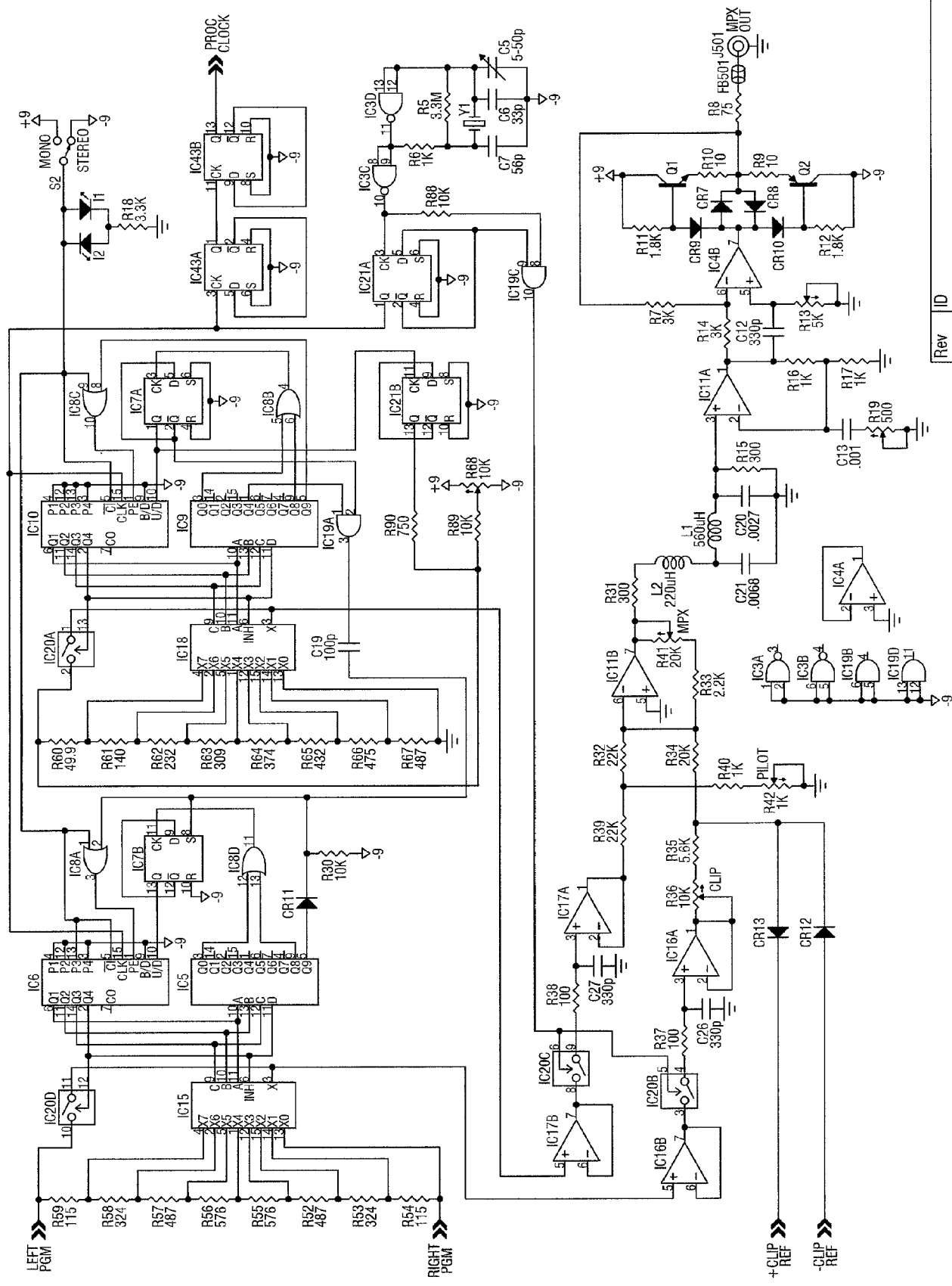



INOVONICS WARRANTY

- I TERMS OF SALE:** Inovonics products are sold with an understanding of “full satisfaction”; that is, full credit or refund will be issued for products sold as new if returned to the point of purchase within 30 days following their receipt, provided that they are returned complete and in an “as received” condition.
- II CONDITIONS OF WARRANTY:** The following terms apply unless amended *in writing* by Inovonics, Inc.
- A. The Warranty Registration Card supplied with this product *must* be completed and returned to Inovonics within 10 days of delivery.
 - B. This Warranty applies only to products sold “as new.” It is extended only to the original end-user and may not be transferred or assigned without prior written approval by Inovonics.
 - C. This Warranty does not apply to damage caused by misuse, abuse, accident or neglect. This Warranty is voided by unauthorized attempts at repair or modification, or if the serial identification label has been removed or altered.
- III TERMS OF WARRANTY:** Inovonics, Inc. products are warranted to be free from defects in materials and workmanship.
- A. Any discrepancies noted within ONE YEAR of the date of delivery will be repaired free of charge, or the equipment will be replaced with a new or remanufactured product at Inovonics’ option.
 - B. Parts and labor for factory repair required after the one-year Warranty period will be billed at prevailing prices and rates.
- IV RETURNING GOODS FOR FACTORY REPAIR:**
- A. Equipment will not be accepted for Warranty or other repair without a Return Authorization (RA) number issued by Inovonics prior to its return. An RA number may be obtained by calling the factory. The number should be prominently marked on the outside of the shipping carton.
 - B. Equipment must be shipped prepaid to Inovonics. Shipping charges will be reimbursed for valid Warranty claims. Damage sustained as a result of improper packing for return to the factory is not covered under terms of the Warranty and may occasion additional charges.