

PB3

Mobile Printer



User's Guide

Intermec Technologies Corporation

Worldwide Headquarters

6001 36th Ave.W.

Everett, WA 98203

U.S.A.

www.intermec.com

The information contained herein is provided solely for the purpose of allowing customers to operate and service Intermec-manufactured equipment and is not to be released, reproduced, or used for any other purpose without written permission of Intermec Technologies Corporation.

Information and specifications contained in this document are subject to change without prior notice and do not represent a commitment on the part of Intermec Technologies Corporation.

© 2008-2009 by Intermec Technologies Corporation. All rights reserved.

The word Intermec, the Intermec logo, Norand, ArciTech, Beverage Routebook, CrossBar, dcBrowser, Duratherm, EasyADC, EasyCoder, EasySet, Fingerprint, i-gistics, INCA (under license), Intellitag, Intellitag Gen2, JANUS, LabelShop, MobileLAN, Picolink, Ready-to-Work, RoutePower, Sabre, ScanPlus, ShopScan, Smart Mobile Computing, SmartSystems, TE 2000, Trakker Antares, and Vista Powered are either trademarks or registered trademarks of Intermec Technologies Corporation.

There are U.S. and foreign patents as well as U.S. and foreign patents pending.

Bluetooth is a trademark of Bluetooth SIG, Inc., U.S.A.

Document Change Record

This page records changes to this document. The document was originally released as Revision 001.

Version Number	Date	Description of Change
002	06/2009	Clarified DIP switch settings, updated software and programming information, and added part numbers for the 2-bay battery charger and VBA accessories.

Contents

Before You Begin.....	vii
Safety Information.....	vii
Global Services and Support.....	vii
Warranty Information.....	vii
Web Support.....	viii
Telephone Support.....	viii
Service Location Support.....	viii
Who Should Read This Manual.....	ix
Related Documents.....	ix
Learning About the PB3 Mobile Printer.....	1
Understanding the Printer Features.....	1
Understanding the LEDs.....	3
Using the Battery and AC Adapter/Charger.....	4
Using the 2-Bay Battery Charger.....	6
Loading Paper.....	7
Tearing Paper.....	9
Using the Belt Loop.....	9
Printing a Configuration Test Page.....	10
Communicating With a Host.....	11
Setting Up Bluetooth or 802.11 Communications.....	12
Setting Up Serial Communications.....	13
Changing Printer Connection Settings.....	13
Using the Magnetic Stripe Reader.....	16
Maintaining the Printer.....	16
Troubleshooting.....	18
Problems and Solutions.....	18
Calling Product Support.....	19
Software and Programming Information.....	20
Downloading Printer Software.....	20
Installing Printer Firmware.....	21
Specifications.....	24
Accessories.....	25
Pinout Diagram.....	25

Contents

Before You Begin

This section provides you with safety information, technical support information, and sources for additional product information.

Safety Information

Your safety is extremely important. Read and follow all warnings and cautions in this document before handling and operating Intermec equipment. You can be seriously injured, and equipment and data can be damaged if you do not follow the safety warnings and cautions.

This section explains how to identify and understand warnings, cautions, and notes that are in this document.



A caution alerts you to an operating procedure, practice, condition, or statement that must be strictly observed to prevent equipment damage or destruction, or corruption or loss of data.



A warning alerts you of an operating procedure, practice, condition, or statement that must be strictly observed to avoid death or serious injury to the persons working on the equipment.



Note: Notes either provide extra information about a topic or contain special instructions for handling a particular condition or set of circumstances.

Global Services and Support

Warranty Information

To understand the warranty for your Intermec product, visit the Intermec web site at www.intermec.com and click **Support > Returns and Repairs > Warranty**.

Disclaimer of warranties: The sample code included in this document is presented for reference only. The code does not necessarily represent complete, tested programs. The code is provided “as is with all faults.” All warranties are expressly disclaimed, including the implied warranties of merchantability and fitness for a particular purpose.

Web Support

Visit the Intermec web site at www.intermec.com to download our current manuals (in PDF). To order printed versions of the Intermec manuals, contact your local Intermec representative or distributor.

Visit the Intermec technical knowledge base (Knowledge Central) at www.intermec.com and click **Support > Knowledge Central** to review technical information or to request technical support for your Intermec product.

Telephone Support

In the U.S.A. and Canada, call **1-800-755-5505**.

Outside the U.S.A. and Canada, contact your local Intermec representative. To search for your local representative, from the Intermec web site, click **About Us > Contact Us**.

Service Location Support

For the most current listing of service locations, go to www.intermec.com and click **Support > Returns and Repairs > Repair Locations**.

For technical support in South Korea, use the after service locations listed below:

AWOO Systems

102-1304 SK Ventium

522 Dangjung-dong

Gunpo-si, Gyeonggi-do Korea, South 435-776

Contact: Mr. Sinbum Kang

Telephone: +82-31-436-1191

E-mail: mjyun@awoo.co.kr

IN Information System PTD LTD
6th Floor
Daegu Venture Center Bldg 95
Shinchun 3 Dong
Donggu, Daegu City, Korea
E-mail: jmyou@idif.co.kr or korlim@gw.idif.co.kr

Who Should Read This Manual

This document is for the person who is responsible for installing, configuring, and maintaining the PB3 Mobile Printer.

This document provides you with information about the features of the PB3, and how to install, configure, operate, maintain, and troubleshoot it.

Before you work with the PB3, you should be familiar with your network and general networking terms, such as IP address.

Related Documents

This table contains a list of related Intermec documents and their part numbers.

Document Title	Part Number
<i>PB3 Mobile Printer Quick Start Guide</i>	930-217-xxx
<i>PB2 and PB3 Battery Instructions</i>	943-217-xxx
<i>XSim Programmer's Reference Manual</i>	937-014-xxx
<i>ESC/P Programmer's Reference Manual</i>	937-010-xxx

The Intermec web site at www.intermec.com contains our documents (as PDF files) that you can download for free.

To download documents

- 1 Visit the Intermec web site at www.intermec.com.
- 2 Click **Support** > **Manuals**.
- 3 Use the **Product Category** field, the **Product Family** field, and the **Product** field to help you locate the product whose documentation you want to download.

Before You Begin

Learning About the PB3 Mobile Printer

The PB3 Mobile Printer is a full-featured portable receipt printer designed for a variety of job environments where point of service receipts are required. The package contains:

- PB3 Mobile Printer
- AC adapter/charger
- Battery
- Belt loop
- Roll of 3-inch receipt paper (already loaded in the printer)
- Printhead cleaning pen
- Product documentation: Quick Start Guide, Compliance Inserts, Battery Instructions, and Warranty Card

For a list of PB3 accessories, see [“Accessories” on page 25](#).

Understanding the Printer Features

The next illustrations show the PB3 controls and ports.

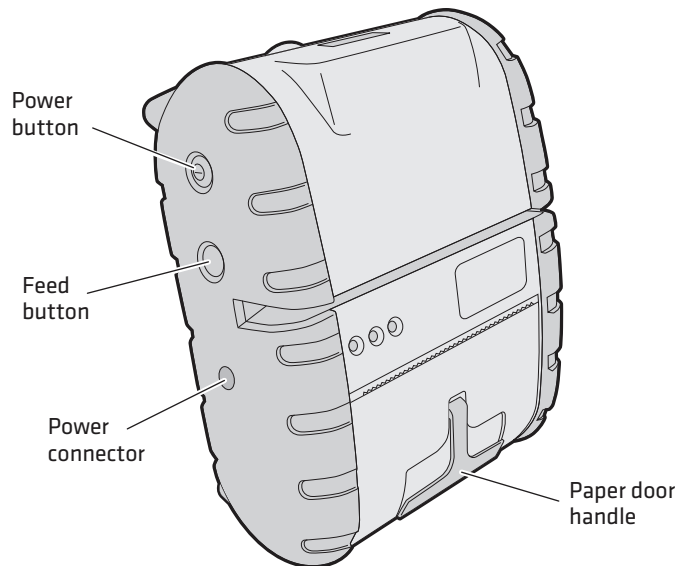

PB3 Controls and Power Connector

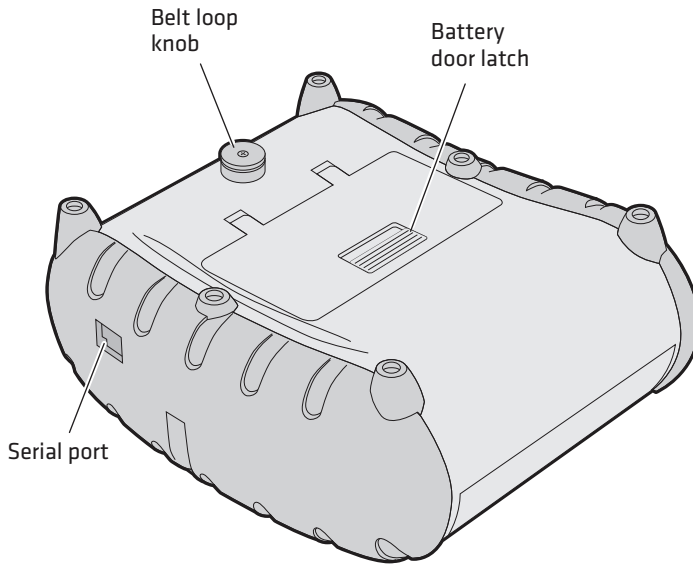

PB3 Serial Port, Belt Loop Knob, and Battery Door Latch

The printer features are described in the next table.

PB3 Feature Descriptions

Feature	Description
Power button	Press once to turn the printer on or off.
Feed button	Press to feed paper out of the printer. You can also press Feed to print a configuration test page. For help, see “Printing a Configuration Test Page” on page 10.
Paper door handle	Pull to open the paper compartment door. For help, see “Loading Paper” on page 7.
Power connector	Connects the printer to the AC adapter/battery charger. For more information, see the next section.
Serial port	Connects the printer to a host computer. Use cable P/N 5892RJD9-1.
Battery door latch	Slide to lock or unlock the battery door. For help, see the next section.
Belt loop knob	Attaches the printer to the included belt loop. For help, see “Using the Belt Loop” on page 9.

Understanding the LEDs

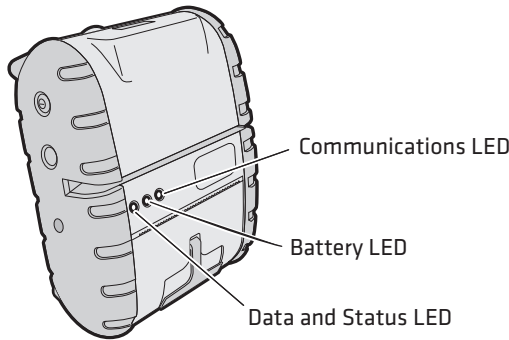

PB3 LED State Descriptions

LED	State	Description
Communications	Flashing Green	Power is on. PB3 is in RS-232 mode.
	Steady Green	PB3 is communicating with host in RS-232 mode.
	Flashing Blue	Power is on. PB3 is in Bluetooth or 802.11 mode.
	Steady Blue	PB3 is communicating via Bluetooth or 802.11 radio.
Battery	Steady Red	Low battery charge.
	Off	Battery fully charged (when printer is connected to AC power).
	Steady Amber	Battery is charging.
Data and Status	Off	Card was read successfully, or card cannot be read (for optional magnetic stripe reader).
	Steady Green	Card reader is ready to accept data (for optional magnetic stripe reader).
	Flashing Red	Printhead is too hot. Printing is paused until printhead reaches normal operating temperature.
	Steady Red	One of three conditions: <ul style="list-style-type: none"> • Printer is out of paper. • The paper door is open. • Card reader error (for optional magnetic stripe reader).

Using the Battery and AC Adapter/Charger



Use Intermec battery model 318-040-001 only. Use of another battery may present a risk of fire or explosion.

The battery used in this device may present a fire or chemical burn hazard if mistreated. Do not disassemble, heat above 80°C (176°F), or incinerate.



Note: The battery must be cycled several times to achieve maximum capacity. To cycle a battery, fully charge it and then allow a full discharge through normal use. To ensure a full charge, do not operate the printer while charging the battery.

To install the battery

- 1 Slide the battery door latch toward the belt loop knob to unlock the battery door, and open the battery door to an angle of about 90 degrees. Do not force the door all the way open.
- 2 Orient the battery so the arrow points toward the battery contacts in the battery compartment.
- 3 Insert the end of the battery without contacts into the battery compartment first. The contact end drops into place.

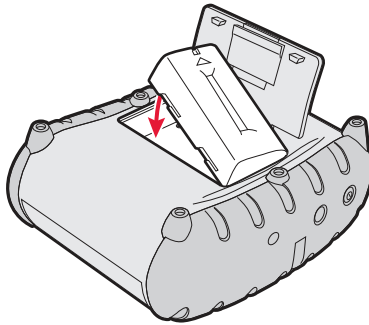

Be sure you insert the battery correctly, or you may damage the battery contacts in the printer.

- 4 Close the battery door and slide the latch away from the belt loop knob to lock the latch.

To remove the battery

- Unlock and open the battery door and tip the printer to one side to remove the battery.

To charge the battery with the AC adapter/charger

- 1 Plug the AC adapter into the power connector.
- 2 Install the appropriate AC plug on the adapter. The adapter comes with four different plugs suitable for most regions worldwide.
- 3 Make sure the printer is off and connect the adapter to AC power. The Battery LED turns on, indicating that the battery is charging.



Note: If the other LEDs turn on, press the **Power** button to turn the printer off.

After about three hours the Battery LED turns off. The battery is fully charged.

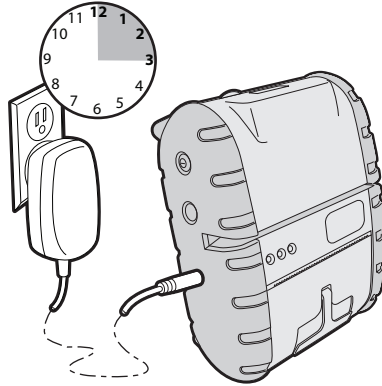

Note: The wall mounted charger is Class II equipment. Multiple plug configurations comply with most international standards. The wall mounted charger is not supplied with plugs for use in Korea.

Using the 2-Bay Battery Charger

Use the 2-bay battery charger to charge the batteries.

To use the 2-bay charger

- 1 Plug the AC adapter into the 2-bay charger.
- 2 Connect the adapter to AC power. The Status LEDs turn green, indicating that the charger is ready to use.

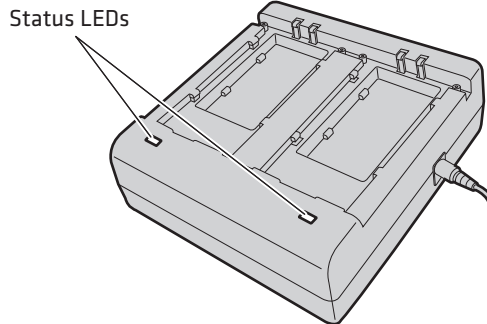

- 3 With the contacts on the bottom and the arrow pointing toward the LEDs, place a battery into one of the bays.
- 4 Slide the battery towards the LEDs. The battery snaps into place.

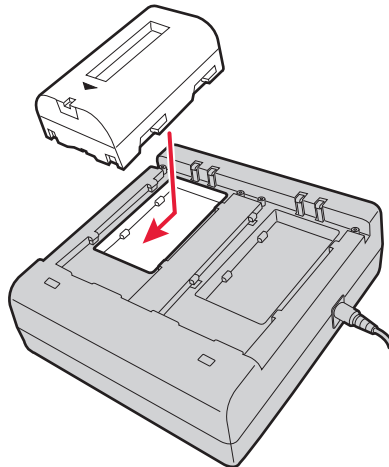

If the battery is not charged, the Status LED for that bay turns red. The Status LED turns green when the battery is charged.

Battery Safety Information

Follow these tips for maintaining the PB3 battery:

- Be sure to fully charge the battery before long printing sessions, such as printing receipts with many bar codes and graphics.
- For maximum battery life, Intermec recommends charging the battery at 25°C (77°F).
- Remove the battery from the printer before storing the printer for long periods of time.
- The battery storage temperature is -20°C to 40°C (-4°F to 104°F). Do not store a fully charged battery at temperatures greater than 40°C (104°F) for long periods of time – the battery may permanently lose charge capacity.
- Dispose of battery according to local regulations. Do not throw in trash.
- Do not disassemble, short circuit, heat above 80°C (176°F), or incinerate. The battery may explode.

For more information, see the *[PB2 and PB3 Battery Instructions](#)*.

Loading Paper



To prevent possible damage to the print mechanism, use only receipt paper rolls that are not fastened to the inside core in any way. Otherwise the core will be pulled into the mechanism causing jamming and possible gear damage.

To load paper

- 1 Lift the paper door handle and pull it gently to open the door.

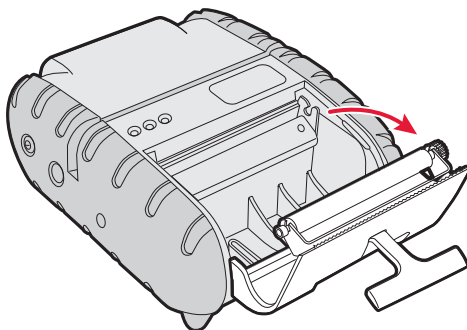
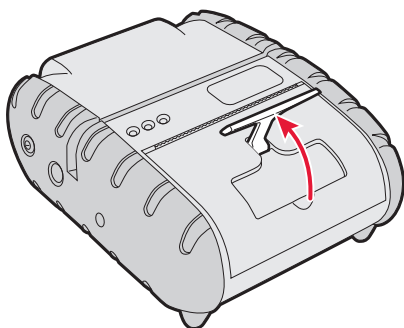

- 2** Place the 3-inch paper roll into the printer as shown in the next illustration. The paper supply should unwind from the bottom.
- 3** Unroll about 3 inches of paper from the roll and position it between the printhead guides.

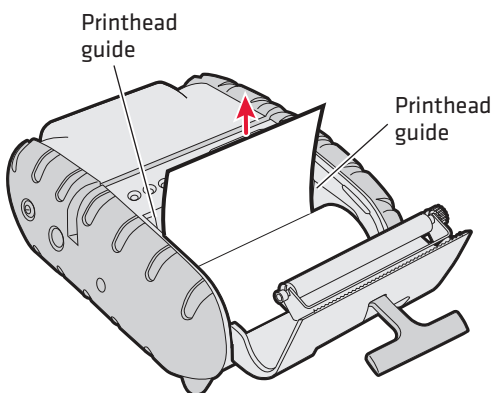

- 4** Close the paper door. The door clicks when completely closed.
- 5** Fold the door handle flush with the printer.

- 6 Press the **Power** button to turn the printer on.
- 7 Press and hold the **Feed** button to verify that the paper advances correctly.

Tearing Paper



Note: Using the tear bar is the only way to tear the paper. Pulling up and pulling sideways without using the tear bar can cause a paper jam.

The paper door acts as a tear bar. Pull one edge of the paper against the tear bar, and then tear down and across against the tear bar to tear the paper.



The tear bar has sharp edges. Be careful when tearing paper or when handling the paper door.

Using the Belt Loop

- 1 Place the belt loop over your belt and snap it to secure it.

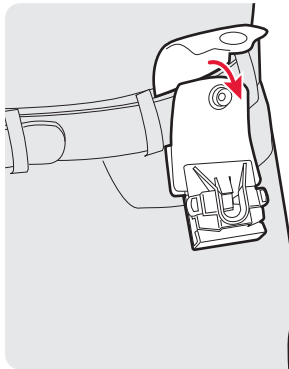

- 2 Insert the belt loop knob into the connector slot on the belt loop and slide the printer down until the knob clicks into place.

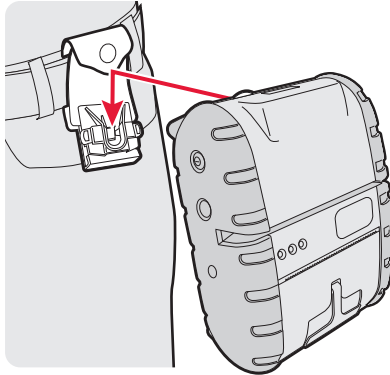

- 3 To disconnect the printer from the belt loop, press both of the connector latches and slide the belt loop knob out of the slot.

Note: Do not try to remove the printer from the belt loop without pressing both latches.



Printing a Configuration Test Page

Once the battery is charged and paper is loaded, you can print a configuration test page. Use this information for reference when installing the PB3 and to verify correct printer operation. If you cannot print the test page, see [“Troubleshooting” on page 18](#).

Note: If you are using the AC adapter/charger as a power source, the printer will not print unless a battery is installed.



To print a test page

- 1 Make sure the printer is off before you begin.
- 2 Press and hold the **Feed** button.
- 3 Press the **Power** button once to turn on the printer. When the printer starts printing the test page, release the **Feed** button.
- 4 To stop or cancel printing the test page, press either the **Power** or **Feed** button.

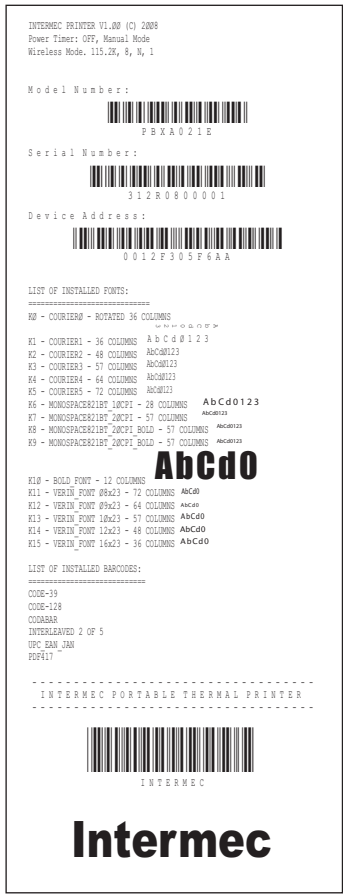

Sample Configuration Test Page

Communicating With a Host

Depending on the configuration you ordered, the PB3 supports either a Bluetooth or 802.11g wireless network connection to a host computer that will send data for the printer to print.

You can also configure the PB3 to use a serial connection instead. For more information on configuring serial connections, see **“Changing Printer Connection Settings” on page 13.**

Setting Up Bluetooth or 802.11 Communications

If your PB3 includes the optional Bluetooth module, the printer is configured by default for Bluetooth connections at a baud rate of 115200. The PB3 cannot initiate a Bluetooth connection. You must connect to the PB3 from a host, such as a handheld computer. See the documentation for your computer for more information on connecting to Bluetooth devices.



Note: When the printer is set for Bluetooth or 802.11 communications, the printer stays on all the time, unless you have enabled the automatic power save feature. When power save is enabled, the printer turns off if no communications are received from the host for 99 seconds. To enable automatic power save, see **“Changing Printer Connection Settings” on page 13.**

The unique Bluetooth Device Address (BDA) for the printer is printed on the battery door certification label.

If your PB3 includes the optional 802.11g radio module, the printer is configured by default for an 802.11g wireless network connection.

The unique MAC address for the printer is printed on the battery door certification label.

Use the PB2 & PB3 Easy Configuration Utility to configure Bluetooth and 802.11 settings. For more information, see the utility online help.

To download the Easy Configuration Utility

- 1 Go to the Intermec web site at www.intermec.com.
- 2 Select **Support > Downloads**.
- 3 In the **Product Category** field, select **Printers and Media**.
- 4 In the **Product Family** field, select **Mobile Printers**.
- 5 In the **Product** field, select **PB2/PB3 Commercial Mobile Receipt**.
- 6 Click **Submit**.
- 7 From the list of available downloads, select the Easy Configuration Utility and follow the prompts to download the application.

Setting Up Serial Communications

For a serial connection to the host computer, you need to:

- configure the PB3 for a serial connection. For help, see the next section.
- connect the PB3 to the host using the optional serial cable (P/N 5892RJD9-1).

For pinouts, see **“Accessories” on page 25.**

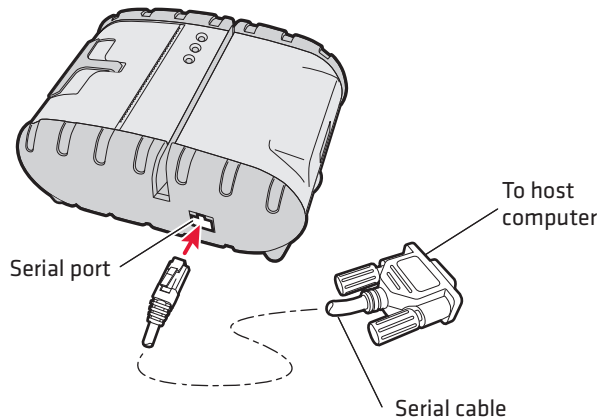

PB3 With Serial Cable

Changing Printer Connection Settings

Connection settings are changed by the DIP switches located inside the battery compartment.

Follow the next procedure to change DIP switch settings.



Use caution when changing DIP switch settings. Carefully use a pointer on the dip switch to toggle its position. Do not use a screwdriver and do not apply excessive force.

To change printer settings with the DIP switches

- 1 Open the battery door and remove the battery. The DIP switches are located inside the battery compartment.

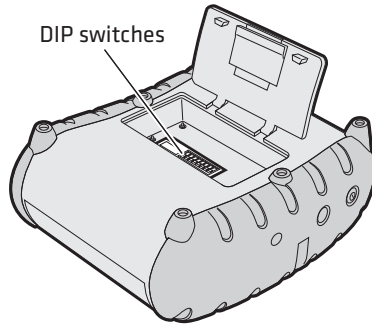

The DIP switches are numbered 1 to 8 from left to right. By default, all DIP switches are off (toggled away from the configuration label inside the battery compartment) except for switch 2.

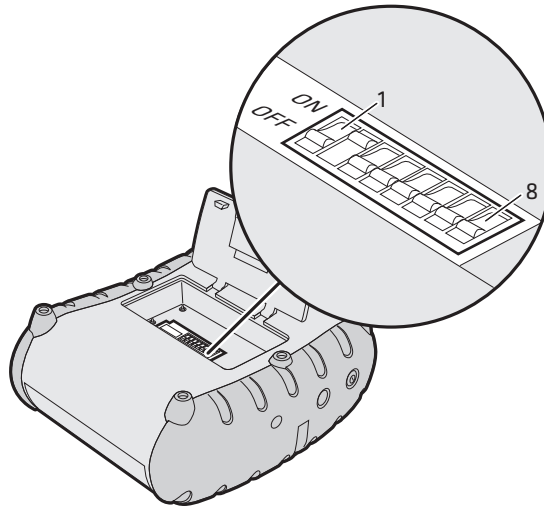

- Change DIP switch settings by carefully pressing a pointer into the switch and sliding it to the other side. For more information, see the next table.

DIP Switch Settings

To Set This Parameter		Turn These DIP Switches On							
		1	2	3	4	5	6	7	8
Enable serial connection									
Enable 802.11 connection		X	X						
Enable Bluetooth connection			X						
Set baud rate:	115200								
	57600			X					
	38400				X				
	19200			X	X				
	14400					X			
	9600			X		X			
	2400				X	X			
	1200			X	X	X			
Parity Bit	Enabled							X	
	Disabled (no parity)								
Odd/Even (Parity Bit must be Enabled)	Even								X
	Odd								
Auto Power Save	Enabled								X
	Disabled								



Note: If you are configuring the PB3 for a Bluetooth or 802.11 connection, make sure DIP switches 3, 4, and 5 are off.

- Install the battery in the printer and close the battery door. The printer is now configured for your connection.

Using the Magnetic Stripe Reader

If your PB3 includes the optional magnetic stripe reader, follow the next procedure to read cards.



Note: You need an application running on the host computer to read data from the card. For more information, see the *XSim Programmer's Reference Manual*.

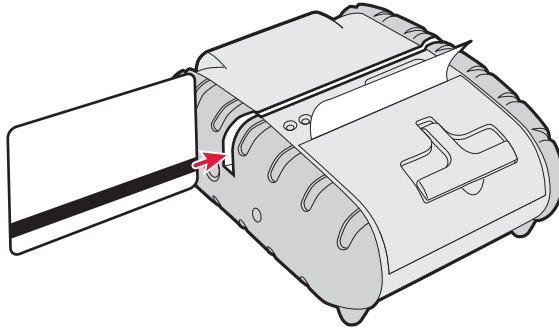

PB3 Magnetic Stripe Reader Slot

To use the magnetic stripe reader

- 1** Position the card so the magnetic stripe faces the paper door.
- 2** Quickly swipe the card through the reader in either direction. The Data and Status LED indicates card reading status as described in **“Understanding the LEDs” on page 3.**

Cleaning cards for the magnetic stripe reader are available from Intermec. For information, contact your local Intermec distributor.

Maintaining the Printer

To clean the exterior of the printer, use a soft cloth and mild cleaner. Do not use abrasive cleaner, chemicals, or scouring pads, as these will damage the finish.

When you load a new roll of paper or when voids in the printout are apparent, clean the printhead and platen roller as described next.



Do not use sharp objects to clean the printhead. This may damage the printer and require service or repair.

To clean the printhead and platen roller

- 1 Remove the paper from the printer. For help, see **“Loading Paper” on page 7.**

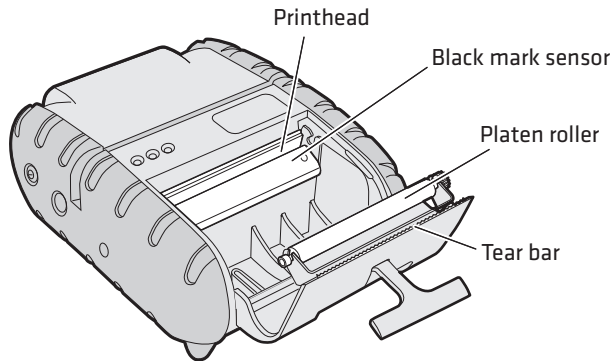

- 2 Clean the printhead with the included cleaning pen or with a cotton swab moistened with isopropyl alcohol.
- 3 Remove buildup from the black mark sensor and tear bar with a cotton swab moistened with isopropyl alcohol.
- 4 Turn the platen roller with your finger and run a dry cloth, small brush, or cotton swab moistened with isopropyl alcohol across the roller. Ensure that the roller is clean all the way around.



Note: Dust build-up may occur depending on the environment and the quality of the paper supply used. Use a can of compressed air to blow dust and paper debris out of the printer.

Troubleshooting

This section contains information about troubleshooting common problems and contacting Product Support.

Problems and Solutions

Most printer operation, print quality, or printer communication problems can be fixed easily. The next table includes some common printer problems and possible solutions.

PB3 Problems and Solutions

Problem	Solution
Printer does not feed paper correctly.	Remove jammed paper and reload paper supply.
Printer does not print.	Make sure the paper supply is loaded correctly. Install a battery. The printer will not print unless a battery is installed, even if you are using the AC adapter/charger as a power source. If you are unable to print from a host computer, try printing a test page. Verify that the communication settings from the test page are correct for your connection. For help, see “Printing a Configuration Test Page” on page 10.
Print quality is too light.	Check the battery and recharge it if necessary. Adjust print contrast through the print application.
Voids appear in print.	Clean the printhead.
Data and Status LED is steady red.	Check the paper supply and make sure the paper door is closed properly.
Data and Status LED is flashing red.	Read error. Try reading the card again. Printhead may be too hot and printer has automatically paused the current print job.
Battery LED does not turn on when printer is connected to AC adapter, but printer will not turn on.	Check the AC adapter output with a multimeter. Output should be 10 VDC. <ul style="list-style-type: none">• If AC output is OK, there is a problem with the battery or battery charge circuit.• If AC output is not OK, replace the adapter.

PB3 Problems and Solutions (continued)

Problem	Solution
Battery life is short after a full charge.	Replace the battery.
In Bluetooth mode, printer does not print data from host.	Move the printer closer to the host. Make sure the host has established a connection with the printer.

Calling Product Support

If you cannot find the answer to your problem at Knowledge Central or in the “PB3 Problems and Solutions” table, you may need to call Intermec Product Support. To talk to a Product Support representative in North America or Canada, call:

1-800-755-5505

Outside the U.S.A. and Canada, go to www.intermec.com and click **Contact** to find your local Intermec representative.

Before you call Intermec Product Support, make sure you have the following information ready:

- Serial number
- Firmware version
- Bluetooth or serial communication settings, such as baud rate

Some printer settings are included on the configuration test page. For help, see **“Printing a Configuration Test Page” on page 10.**

Visit the Intermec technical knowledge base (Knowledge Central) at www.intermec.com and click **Support > Knowledge Central** to review technical information or to request technical support for your Intermec product.

Software and Programming Information

Intermec offers a variety of printer software, such as applications, utilities, and periodic firmware updates.

Downloading Printer Software

You can download printer software from the Intermec web site.

To download printer software

- 1 Go to the Intermec web site at www.intermec.com.
- 2 Select **Support** > **Downloads**.
- 3 In the **Product Category** field, select **Printers and Media**.
- 4 In the **Product Family** field, select **Mobile Printers**.
- 5 In the **Product** field, select **PB2/PB3 Commercial Mobile Receipt**.
- 6 Click **Submit**.
- 7 From the list of available downloads, select a file name and follow the prompts to download the file.

The PB3 is compatible with the XSim printer language, as well as with a subset of ESC/P commands. For more information, see one of these manuals:

- *XSim Programmer's Reference Manual*
- *ESC/P Programmer's Reference Manual*

Intermec's Printing Resource Kit provides tools for developing mobile printing solutions for the PB3. For more information, visit www.intermec.com and choose **Products** > **Applications & Software** > **Developer Library** > **Developer Resource Kits**.



Note: You can also download SDKs from www.fieldsoftware.com to help develop mobile printing solutions for certain language sets:

- PrinterCE SDK
- PrinterCE.NetCF SDK
- PocketHTMLprint SDK

Installing Printer Firmware

When you install printer firmware, you also need to configure your printer hardware. Before getting started, make sure that:

- your printer is set to serial mode (all DIP switches are off).
- the paper roll is properly seated on your printer.
- your printer is connected to your host PC with a serial cable.
- LED #1 is on (green).
- you have the Tera Term application installed on your host PC. Tera Term is a free, open-source terminal emulator program available from the Internet.
- you have the Tera Term macro ConfigurationHardwareInformationTTMacro.ttl installed on your PC. You can download the macro from the PB3 downloads page from the Intermec web site at www.intermec.com.

To install firmware and configure printer hardware

Use only firmware files provided by Intermec.



- 1 Print a configuration test page. For help, see “[Printing a Configuration Test Page](#)” on page 10.
- 2 Configure the printer for a serial connection and connect it to the host computer with a serial cable. For help, see “[Setting Up Serial Communications](#)” on page 13.
- 3 Open a communications program such as HyperTerminal or Tera Term. The printer turns on when the program connects to the printer.



Note: If the printer does not turn on, you need to cycle power to the printer. Remove and install the battery, or unplug and connect the AC power connector.

- 4 As soon as you see the text `boot loader v1.xx`, press **Backspace**. This message appears:
`Erase user code?`

5 Press **Y**. This message appears:

```
Erasing...  
Erased Internal Bank 0.  
Erased External Flash Chip.  
Send a Hex File.
```

6 Send the firmware file to the printer. The printer loads the new firmware, which takes 4 to 5 minutes. When the firmware is loaded, the printer responds with Done.

7 Start the Tera Term application.

8 From the **Setup** menu, select **Serial port**.

9 Configure the serial port settings as shown:

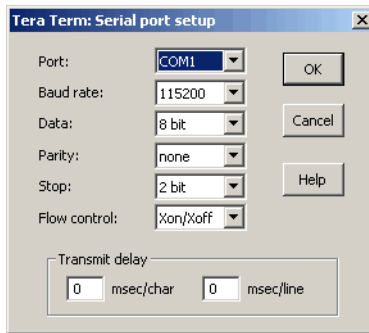

10 Click **OK**.

11 Select **Control > Macro**.

12 Browse to the location of the ConfigurationHardwareInformationTTMacro.ttl file.

13 Select and open the file.

14 In the **Enter Printer MODEL Number** field, enter the printer model number from the configuration test page, and click **OK**.

15 In the **Enter Printer SERIAL Number** field, enter the printer serial number from the configuration test page, and click **OK**.

- 16** In the **Enter Wireless DEVICE Address** field, enter the wireless device address from the configuration test page, and click **OK**.

When the hardware configuration process is done, the Flash load message and bootloader message appear.

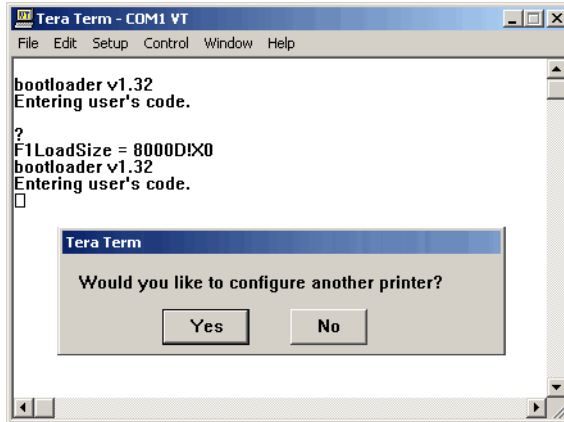

- 17** Print a configuration test page. For help, see **“Printing a Configuration Test Page” on page 10**.
- 18** Make sure that the Model Number, Serial Number, and Device Address on the test page you printed in Step 17 matches the information on the test page you printed in Step 1.

Specifications

PB3 Mobile Printer Specifications

Specification	Description
Height	57 mm (2.25 in)
Width	120 mm (4.75 in)
Length	152 mm (6 in)
Weight (with battery and paper)	0.58 kg (1.3 lb)
Power	7.4 V Li-ion battery, 2200 mAH
Operating temperature	-10°C to 50°C (14°F to 122°F)
Storage temperature	-20°C to 60°C (-4°F to 140°F)
Operating humidity	20% to 85% non-condensing
Storage humidity	5% to 95% non-condensing
Printhead	80 mm (3 in) wide, 203 dpi (8 dots/mm)
Print method	Direct thermal
Print speed	Up to 5.6 cm/sec (2 in/sec)
Character sets	Standard: English/Latin Optional: Arabic, Simplified Chinese, Traditional Chinese, Cyrillic, Greek, Hebrew, Polish
Supported bar codes	Codabar, Code 39, UCC/EAN-128, EAN/UPC, Interleaved 2 of 5, Code 128, PDF417
Memory	1 MB RAM, 4 MB program flash
Charge time	Approximately 180 min
Communications	Serial (RS-232), Bluetooth, 802.11g, IrDA
Print ratio	25% black max/sq in

Accessories

These accessories (sold and ordered separately) are available from Intermec:

- Battery (P/N 318-040-001)
- AC Adapter/Charger (P/N 157261). Charges the battery and runs the printer on AC power (battery must be installed or printer will not print).
- Shoulder Strap (P/N 757351)
- Printhead Cleaning Pen (P/N 757150)
- Magnetic Stripe Reader (MSR) Cleaning Cards (P/N 757160)
- Serial Cable (P/N 5892RJD9-1)
- 3-inch Receipt Paper (P/N E24789)
- Belt loop (P/N 756998-2)
- 2-Bay Battery Charger (P/N 767400)
- Vehicle Battery Adapter (VBA)/cigarette lighter charger (P/N 852-043-004)

Pinout Diagram



Serial Port Pin Assignments

Pin	Signal	Description
1, 5	COM	Logic common
2	TXD	RS-232 from printer (output)
3	RXD	RS-232 from host (input)
4	CTS	Clear to send from printer (output)
6	RTS	Request to send from host (input)



Worldwide Headquarters
6001 36th Avenue West
Everett, Washington 98203
U.S.A.

tel 425.348.2600

fax 425.355.9551

www.intermec.com

© 2009 Intermec Technologies
Corporation. All rights reserved.

PB3 Mobile Printer User's Guide



P/N 934-043-002