

mini **PRO**

USER'S MANUAL

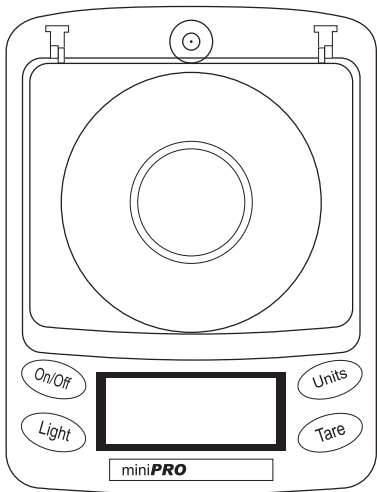

mini **PRO**-100 (100 x 0.002g)



AMERICAN WEIGH
SCALES INC.

American Weigh
miniPRO-100 User's Manual
100g x 0.002g

Thank you for purchasing the mini**PRO** Portable Precision Balance. With normal care and proper treatment, it will provide you with years of reliable service. Please read all operating instructions carefully before using the scale.

- Avoid any exposure to extreme heat or cold. Your scale will work better when operating in normal room temperature. Always allow the scale to acclimate to normal room temperature for at least an hour before use.
- Give the scale sufficient warm up time before use. Usually 30 to 60 seconds to give the internal components time to stabilize.
- Keep your scale in a clean environment. Dust, dirt, moisture, vibration, air currents, or a close proximity to other electronic equipment can cause an adverse effect on the reliability and accuracy of your scale.
- Handle with care. Gently apply all items to be weighed onto the weighing surface. Although this scale is designed to be quite durable, avoid rough treatment as this may permanently damage the internal sensor.
- Do not shake, drop, or otherwise shock the scale. This is a precision instrument and must be handled with extreme care.
- Only operate the scale on a stable, vibration free surface.
- Always store in a dry place to avoid moisture accumulation on internal components.

I. Parts Description

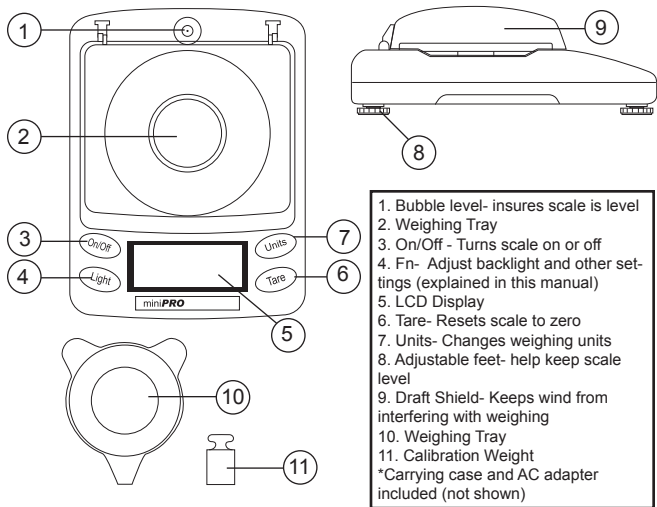

II. Operation

This scale operates using either 4 AAA batteries or an included AC Adapter. Insure the scale is plugged into a wall outlet, or has battery power before use. To operate, set the balance on a flat / stable surface away from interference from wind, vibration, and radio waves. If needed, you may adjust the scales feet to insure that the scale is level. Press the "On/Off" key to begin weighing. Once the scale reads "0.000", you may place the item to be weighed onto the center of the platform.

III. Weighing Units

This scale can weigh in either grams, ounces, troy ounces, pennyweights, grains, or carats. To change the active weighing unit, press the “Units” key. The scale also remembers the last unit used. Therefore, the next time the scale is turned on, it will revert to the previously used weighing unit. You may change weighing units in the middle of weighing as well.

IV. Tare Feature

Tare allows you to subtract the weight of a container (ie. the included weighing tray) in order to obtain the weight of objects in the container (net weight). To use the scales “Tare” button, turn the scale on in normal weighing mode and wait for the screen to show “0.000”. Place the container you wish to use on the scale then press the “Tare” button. The weight of the container is now subtracted and the scale should read 0.000 again. If you now remove the container, a negative value will be shown. If you wish to clear the negative value, press “Tare” again.

V. Backlight

This scale has a backlight with adjustable settings. To change the backlight’s parameters, press the “Fn” key two times. The scale will display **F1**, meaning the backlight will come on when weight is on the scale. To cycle through the different modes, press the “Unit” key. Press the “Tare” key to confirm your selection.

F1: Backlight will come on when weight is on the scale.

F2: Backlight is always on.

F3: Backlight is always off.

VI. Auto-Off Feature

This scale can has an Auto-Off feature that can help battery life by turning the scale off when not in use for a certain amount of time (1-9 minutes). To change the Auto-Off timer, press the “Fn” button three times. The scale will show the current Auto-Off setting (OFF, 60, 120, 180, 240, 300, 360, 420, 480, or 540) Press the “Unit” button to cycle through until you find the desired timer duration (in seconds). Press “Tare” to confirm your selection.

VII. Calibration

If the scale is not performing properly or is displaying incorrect weight, you may need to recalibrate the scale. Typically, the Standard Calibration method is sufficient for the average user to recalibrate their scale. Advanced calibration is already performed at the factory and should not be attempted unless you are still having problems. Before starting calibration, insure that the area you are working in is free of drafts, vibration, and all radio-wave emitting devices (cordless phones etc).

• Standard Calibration:

You will need either a 50 gram or a 100 gram weight to perform calibration. Press the “Fn” button one time, “SCALE” will be displayed on the LCD; Press the “Tare” button to continue. The scale will display 50.000, you can change this to 100.000 by pressing the “Unit” button. Select the value that corresponds to your calibration weight and press “Tare” to confirm your selection. The value you selected will flash on the screen. At this time, place your calibration weight onto the weighing surface. In a few seconds, the display will stop flashing, and the weight value will be shown. Calibration is complete!

• Advanced Calibration:

You will need both a 50 gram and a 100 gram weight to perform calibration (or two 50 gram weights). Press the “Fn” button one time, “SCALE” will be displayed on the LCD; Press the “Units” button once to change to “LINE” mode, then press “Tare” to confirm. The scale will display 50.000, press “Tare” again to confirm. The display will flash “50.000”. At this time, place a 50 gram weight on the center of the weighing platform. In a few seconds, the display will change to “100.000”. At this time, either add a second 50g , or remove the 50g and replace it with a 100g weight (there should be 100g on the scale at this point). The display will now show “100.000”. Calibration is complete!

Auto Off Duration (seconds)	60, 120, 180, 240, 300, 360, 420, 480, 540, off
Weight (lb)	0.58 lb
Tare Range	To full capacity by subtraction
Pan Size (mm)	Ø 2.75" (70 mm)
Capacity mini PRO 100	100g x 0.002g 3.5273oz x 0.0001oz 3.2150ozt x 0.0001ozt 64.300dwt x 0.002dwt 1543.25gn x 0.05gn 500.00ct x 0.01ct
Power	4 x AAA Batteries (not included) AC Power Adapter (included)
Dimensions	5.25" x 3.75" x 2.0"