



IW12

HYDRAULIC IMPACT WRENCH



SAFETY, OPERATION AND MAINTENANCE USER MANUAL



© 2012 Stanley Black & Decker, Inc.
New Britain, CT 06053
U.S.A.
66023 9/2013 Ver. 8

DECLARATION OF CONFORMITY

DECLARATION OF CONFORMITY
ÜBEREINSTIMMUNGS-ERKLÄRUNG
DECLARATION DE CONFORMITE CEE
DECLARACION DE CONFORMIDAD
DICHIARAZIONE DI CONFORMITA



I, the undersigned:
Ich, der Unterzeichnende:
Je soussigné:
El abajo firmante:
Io sottoscritto:

Weisbeck, Andy

Surname and First names/Familiennamen und Vornamen/Nom et prénom/Nombre y apellido/Cognome e nome

hereby declare that the equipment specified hereunder:
bestätige hiermit, daß erklaren Produkt genannten Werk oder Gerät:
déclare que l'équipement visé ci-dessous:
Por la presente declaro que el equipo se especifica a continuación:
Dichiaro che le apparecchiature specificate di seguito:

- Category: **Hydraulic Hand Held Impact Wrench**
Kategorie:
Catégorie:
Categoria:
Categoria:
- Make/Marke/Marque/Marca/Marca **Stanley**
- Type/Typ/Type/Tipo/Tipo: **IW1214001, IW1234001, IW12140AX**
- Serial number of equipment:
Seriennummer des Geräts:
Numéro de série de l'équipement:
Numero de serie del equipo:
Matricola dell'attrezzatura:
All

Has been manufactured in conformity with
Wurde hergestellt in Übereinstimmung mit
Est fabriqué conformément
Ha sido fabricado de acuerdo con
E' stata costruita in conformità con

Directive/Standards Richtlinie/Standards Directives/Normes Directriz/Los Normas Direttiva/Norme	No. Nr Numéro No n.	Approved body Prüfung durch Organisme agréé Aprobado Collaudato
EN	792-6:1994	Self
EN ISO	3744:2009	Self
EN	28662-7:2009	Self
ISO	28927-2:2009	Self
Machinery Directive	2006/42/EC:2006	Self

- Special Provisions: **None**
Spezielle Bestimmungen:
Dispositions particulières:
Provisiones especiales:
Disposizioni speciali:
- Representative in the Union: **Patrick Vervier, Stanley Dubuis 17-19, rue Jules Berthonneau-BP 3406 41034 Blois Cedex, France.**
Vertreter in der Union/Représentant dans l'union/Representante en la Union/Rappresentante presso l'Unione

Done at/Ort/Fait à/Dado en/Fatto a Stanley Hydraulic Tools, Milwaukie, Oregon USA Date/Datum/le/Fecha/Data 1-5-11

Signature/Unterschrift/Signature/Firma/Firma

Andy Weisbeck

Position/Position/Fonction/Cargo/Posizione Engineering Manager

Rev.7 1/5/2011

TABLE OF CONTENTS

DECLARATION OF CONFORMITY	2
SAFETY SYMBOLS	4
SAFETY PRECAUTIONS.....	5
TOOL STICKERS & TAGS	6
HOSE TYPES.....	7
HOSE RECOMMENDATIONS	8
FIGURE 1. TYPICAL HOSE CONNECTIONS	8
HTMA REQUIREMENTS.....	9
OPERATION.....	10
TOOL PROTECTION & CARE	12
TROUBLESHOOTING	13
SPECIFICATIONS.....	14
ACCESSORIES.....	14
IW12 STD IMPACT MECHANISM ILLUSTRATION	15
STANDARD IMPACT MECHANISM PARTS LIST.....	16
HEAVY DUTY IMPACT MECHANISM ILLUSTRATION	17
HEAVY DUTY IMPACT MECHANISM PARTS LIST	18
STANDARD IMPACT & HEAVY DUTY IMPACT MECHANISMS IN DETAIL	19

IMPORTANT

To fill out a Product Warranty Recording form, and for information on your warranty, visit Stanleyhydraulic.com and select the Warranty tab.
(NOTE: The warranty recording form must be submitted to validate the warranty).

SERVICING THE STANLEY HYDRAULIC IMPACT WRENCH. This manual contains safety, operation, and routine maintenance instructions. Stanley Hydraulic Tools recommends that servicing of hydraulic tools, other than routine maintenance, must be performed by an authorized and certified dealer. Please read the following warning.

⚠ WARNING

SERIOUS INJURY OR DEATH COULD RESULT FROM THE IMPROPER REPAIR OR SERVICE OF THIS TOOL.

REPAIRS AND / OR SERVICE TO THIS TOOL MUST ONLY BE DONE BY AN AUTHORIZED AND CERTIFIED DEALER.

For the nearest authorized and certified dealer, call Stanley Hydraulic Tools at the number listed on the back of this manual and ask for a Customer Service Representative.

SAFETY SYMBOLS

Safety symbols and signal words, as shown below, are used to emphasize all operator, maintenance and repair actions which, if not strictly followed, could result in a life-threatening situation, bodily injury or damage to equipment.



▲ DANGER

This is the safety alert symbol. It is used to alert you to potential personal injury hazards. Obey all safety messages that follow this symbol to avoid possible injury or death.

▲ WARNING

This safety alert and signal word indicate an imminently hazardous situation which, if not avoided, will result in death or serious injury.

▲ CAUTION

This safety alert and signal word indicate a potentially hazardous situation which, if not avoided, could result in death or serious injury.

CAUTION

This safety alert and signal word indicate a potentially hazardous situation which, if not avoided, could result in death or serious injury.

NOTICE

This signal word indicates a potentially hazardous situation which, if not avoided, may result in property damage.

IMPORTANT

This signal word indicates a situation which, if not avoided, will result in damage to the equipment.

This signal word indicates a situation which, if not avoided, may result in damage to the equipment.

Always observe safety symbols. They are included for your safety and for the protection of the tool.

LOCAL SAFETY REGULATIONS

Enter any local safety regulations here. Keep these instructions in an area accessible to the operator and maintenance personnel.

SAFETY PRECAUTIONS

Tool operators and maintenance personnel must always comply with the safety precautions given in this manual and on the stickers and tags attached to the tool and hose. These safety precautions are given for your safety. Review them carefully before operating the tool and before performing general maintenance or repairs.

Supervising personnel should develop additional precautions relating to the specific work area and local safety regulations. If so, place the added precautions in the space provided on in this manual.

The model IW12 Hydraulic Impact Wrench will provide safe and dependable service if operated in accordance with the instructions given in this manual. Read and understand this manual and any stickers and tags attached to the tool and hose before operation.

Failure to do so could result in personal injury or equipment damage.



- The operator must start in a work area without bystanders. Flying debris can cause serious injury.
- Do not operate the tool unless thoroughly trained or under the supervision of an instructor. Establish a training program for all operators to ensure safe operation.
- Always wear safety equipment such as goggles, gloves, ear, head and breathing protection, and safety shoes at all times when operating the tool. Use gloves and aprons when necessary.
- Inspect tool daily for loose fasteners, missing parts and leakage. Have tool repaired if necessary.
- The operator must be familiar with all prohibited work areas such as excessive slopes and dangerous terrain conditions.
- Maintain proper footing and balance at all times and do not overreach.
- Do not inspect or clean the tool while the hydraulic power source is connected. Accidental engagement of the tool can cause serious injury. Be observant of hydraulic and water hose lying about the work area, as they can be a tripping hazard.
- Always connect hoses to the tool hose couplers before energizing the hydraulic power source. Be sure all hose connections are tight and are in good condition.
- Do not operate the tool at oil temperatures above 140 °F/60 °C. Operation at higher temperatures can cause higher than normal temperatures at the tool which can result in operator discomfort.
- Do not operate a damaged, improperly adjusted, or incompletely assembled impact wrench.
- Never wear loose clothing that can get entangled in the working parts of the tool.
- Keep all parts of your body away from the rotating parts. Long hair or loose clothing can become drawn into rotating components.
- Always use accessories that conform to the specifications given in the OPERATION section of this manual.
- Do not reverse impact wrench rotation direction by changing fluid flow direction.
- Release the trigger if the power supply has been interrupted.
- When working near electrical conductors, always assume that all conductors are energized and that insulation, clothing and hoses can conduct electricity. Use hose labeled and certified as non-conductive.
- To avoid personal injury or equipment damage, all tool repair, maintenance and service must only be performed by authorized and properly trained personnel.
- Serious injury or death could result from a tool or accessories dropped from an elevated height.
- Warning: Hydraulic fluid under pressure could cause skin injection injury. If you are injured by hydraulic fluid, get medical attention immediately.
- During operation do not contact the impact mechanism, accessories or hardware as they can become very hot; use your (PPE) Personal Protection Equipment.
- **Warning:** Use of this tool on certain materials during demolition could generate dust potentially containing a variety of hazardous substances such as asbestos, silica or lead. Inhalation of dust containing these or other hazardous substances could result in serious injury, cancer or death. Protect yourself and those around you. Research and understand the materials you are cutting. Follow correct safety procedures and comply with all applicable national, state or provisional health and safety regulations relating to them, including, if appropriate arranging for the safe disposal of the materials by a qualified person.

TOOL STICKERS & TAGS

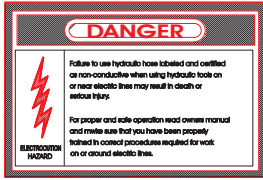

12412
DANGER DECAL

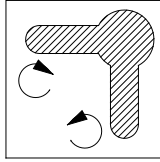

29083
ROTATION DIRECTION
DECAL



25610
RAILROAD HELP DESK
DECAL



28788
Manual
Sticker



28322
CE DECAL (CE)



11207
CIRCUIT TYPE D
DECAL (CE)

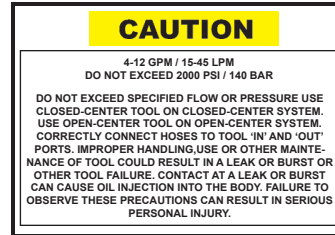

03788
GPM DECAL

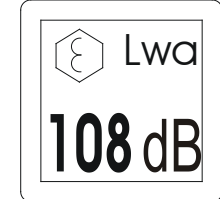

29530
SOUND POWER
LEVEL DECAL (CE)

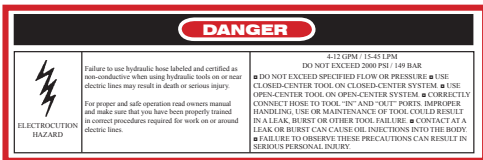

17275
GPM/PRESSURE DANGER DECAL

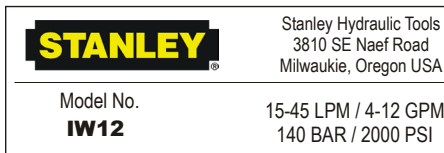

08012
IW12 NAME TAG (US & CE)

NOTE:
THE INFORMATION LISTED ON THE STICKERS SHOWN, MUST BE LEGIBLE AT ALL TIMES.
REPLACE DECALS IF THEY BECOME WORN OR DAMAGED. REPLACEMENTS ARE AVAILABLE FROM YOUR LOCAL STANLEY DISTRIBUTOR.

The safety tag (P/N 15875) at right is attached to the tool when shipped from the factory. Read and understand the safety instructions listed on this tag before removal. We suggest you retain this tag and attach it to the tool when not in use.

DANGER

- FAILURE TO USE HYDRAULIC HOSE LABELED AND CERTIFIED AS NON-CONDUCTIVE WHEN USING HYDRAULIC TOOLS ON OR NEAR ELECTRICAL LINES MAY RESULT IN DEATH OR SERIOUS INJURY.
BEFORE USING HOSE LABELED AND CERTIFIED AS NON-CONDUCTIVE ON OR NEAR ELECTRICAL LINES BE SURE THE HOSE IS MAINTAINED AS NON-CONDUCTIVE. THE HOSE SHOULD BE REGULARLY TESTED FOR ELECTRIC CURRENT LEAKAGE IN ACCORDANCE WITH YOUR SAFETY DEPARTMENT INSTRUCTIONS.
- A HYDRAULIC LEAK OR BURST MAY CAUSE OIL INJECTION INTO THE BODY OR CAUSE OTHER SEVERE PERSONAL INJURY.
 - DO NOT EXCEED SPECIFIED FLOW AND PRESSURE FOR THIS TOOL. EXCESS FLOW OR PRESSURE MAY CAUSE A LEAK OR BURST.
 - DO NOT EXCEED RATED WORKING PRESSURE OF HYDRAULIC HOSE USED WITH THIS TOOL. EXCESS PRESSURE MAY CAUSE A LEAK OR BURST.
 - CHECK TOOL HOSE COUPLERS AND CONNECTORS DAILY FOR LEAKS. DO NOT FEEL FOR LEAKS WITH YOUR HANDS. CONTACT WITH LEAK MAY RESULT IN SEVERE PERSONAL INJURY.

IMPORTANT

READ OPERATION MANUAL AND SAFETY INSTRUCTIONS FOR THIS TOOL BEFORE USING IT.

USE ONLY PARTS AND REPAIR PROCEDURES APPROVED BY STANLEY AND DESCRIBED IN THE OPERATION MANUAL.

TAG TO BE REMOVED ONLY BY TOOL OPERATOR.

SEE OTHER SIDE

DANGER

- DO NOT LIFT OR CARRY TOOL BY THE HOSES. DO NOT ABUSE HOSE. DO NOT USE KINKED, TORN OR DAMAGED HOSE.
- MAKE SURE HYDRAULIC HOSES ARE PROPERLY CONNECTED TO THE TOOL BEFORE PRESSURING SYSTEM. SYSTEM PRESSURE HOSE MUST ALWAYS BE CONNECTED TO TOOL "IN" PORT. SYSTEM RETURN HOSE MUST ALWAYS BE CONNECTED TO TOOL "OUT" PORT. REVERSING CONNECTIONS MAY CAUSE REVERSE TOOL OPERATION WHICH CAN RESULT IN SEVERE PERSONAL INJURY.
- DO NOT CONNECT OPEN-CENTER TOOLS TO CLOSED-CENTER HYDRAULIC SYSTEMS. THIS MAY RESULT IN LOSS OF OTHER HYDRAULIC FUNCTIONS POWERED BY THE SAME SYSTEM AND/OR SEVERE PERSONAL INJURY.
- BYSTANDERS MAY BE INJURED IN YOUR WORK AREA. KEEP BYSTANDERS CLEAR OF YOUR WORK AREA.
- WEAR HEARING, EYE, FOOT, HAND AND HEAD PROTECTION.
- TO AVOID PERSONAL INJURY OR EQUIPMENT DAMAGE, ALL TOOL REPAIR MAINTENANCE AND SERVICE MUST ONLY BE PERFORMED BY AUTHORIZED AND PROPERLY TRAINED PERSONNEL.

IMPORTANT

READ OPERATION MANUAL AND SAFETY INSTRUCTIONS FOR THIS TOOL BEFORE USING IT.

USE ONLY PARTS AND REPAIR PROCEDURES APPROVED BY STANLEY AND DESCRIBED IN THE OPERATION MANUAL.

TAG TO BE REMOVED ONLY BY TOOL OPERATOR.

SEE OTHER SIDE

SAFETY TAG P/N 15875 (Shown smaller than actual size)

The rated working pressure of the hydraulic hose must be equal to or higher than the relief valve setting on the hydraulic system. There are three types of hydraulic hose that meet this requirement and are authorized for use with Stanley Hydraulic Tools. They are:

Certified non-conductive — constructed of thermoplastic or synthetic rubber inner tube, synthetic fiber braid reinforcement, and weather resistant thermoplastic or synthetic rubber cover. *Hose labeled **certified non-conductive** is the only hose authorized for use near electrical conductors.*

Wire-braided (conductive) — constructed of synthetic rubber inner tube, single or double wire braid reinforcement, and weather resistant synthetic rubber cover. *This hose is **conductive** and must never be used near electrical conductors.*

Fabric-braided (not certified or labeled non-conductive) — constructed of thermoplastic or synthetic rubber inner tube, synthetic fiber braid reinforcement, and weather resistant thermoplastic or synthetic rubber cover. *This hose is **not certified non-conductive** and must never be used near electrical conductors.*

HOSE SAFETY TAGS

To help ensure your safety, the following DANGER tags are attached to all hose purchased from Stanley Hydraulic Tools. **DO NOT REMOVE THESE TAGS.**

If the information on a tag is illegible because of wear or damage, replace the tag immediately. A new tag may be obtained from your Stanley Distributor.

THE TAG SHOWN BELOW IS ATTACHED TO “CERTIFIED NON-CONDUCTIVE” HOSE

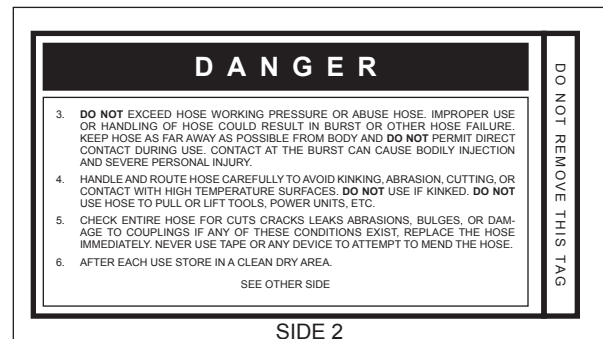
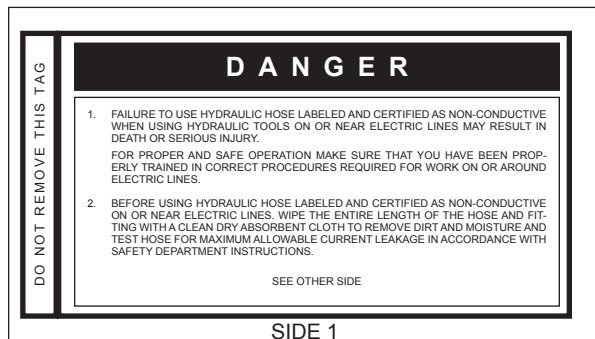

(Shown smaller than actual size)

THE TAG SHOWN BELOW IS ATTACHED TO “CONDUCTIVE” HOSE.

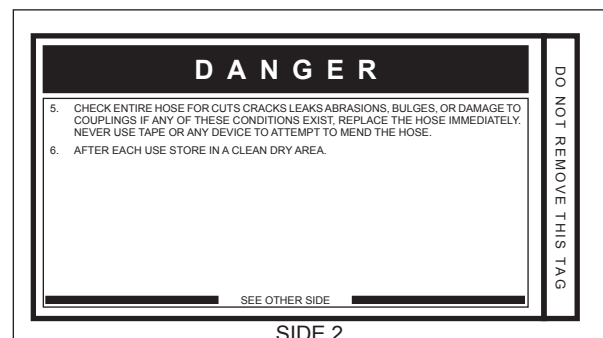
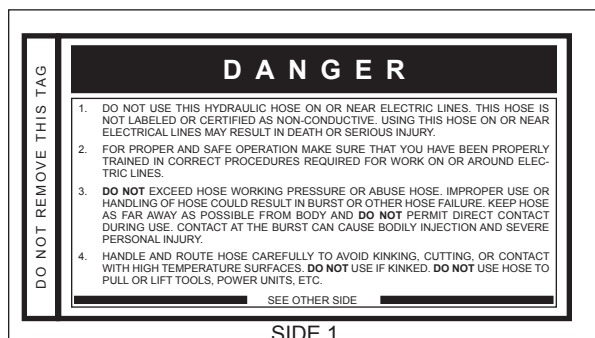

(Shown smaller than actual size)

HOSE RECOMMENDATIONS

Tool to Hydraulic Circuit Hose Recommendations

The chart to the right shows recommended minimum hose diameters for various hose lengths based on gallons per minute (gpm)/liters per minute (lpm). These recommendations are intended to keep return line pressure (back pressure) to a minimum acceptable level to ensure maximum tool performance.

This chart is intended to be used for hydraulic tool applications only based on Stanley Hydraulic Tools tool operating requirements and should not be used for any other applications.

All hydraulic hose must have at least a rated minimum working pressure equal to the maximum hydraulic system relief valve setting.

All hydraulic hose must meet or exceed specifications as set forth by SAE J517.

Oil Flow		Hose Lengths		Inside Diameter		USE (Press/Return)	Min. Working Pressure	
GPM	LPM	FEET	METERS	INCH	MM		PSI	BAR
Certified Non-Conductive Hose - Fiber Braid - for Utility Bucket Trucks								
4-9	15-34	up to 10	up to 3	3/8	10	Both	2250	155
Conductive Hose - Wire Braid or Fiber Braid -DO NOT USE NEAR ELECTRICAL CONDUCTORS								
4-6	15-23	up to 25	up to 7.5	3/8	10	Both	2500	175
4-6	15-23	26-100	7.5-30	1/2	13	Both	2500	175
5-10.5	19-40	up to 50	up to 15	1/2	13	Both	2500	175
5-10.5	19-40	51-100	15-30	5/8	16	Both	2500	175
5-10.5	19-40	100-300	30-90	5/8	16	Pressure	2500	175
10-13	38-49	up to 50	up to 15	3/4	19	Return	2500	175
10-13	38-49	51-100	15-30	5/8	16	Both	2500	175
10-13	38-49	100-200	30-60	3/4	19	Pressure	2500	175
13-16	49-60	up to 25	up to 8	5/8	16	Pressure	2500	175
13-16	49-60	26-100	8-30	3/4	19	Return	2500	175
				1	25.4	Return	2500	175
				5/8	16	Pressure	2500	175
				3/4	19	Return	2500	175
				3/4	19	Pressure	2500	175
				1	25.4	Return	2500	175

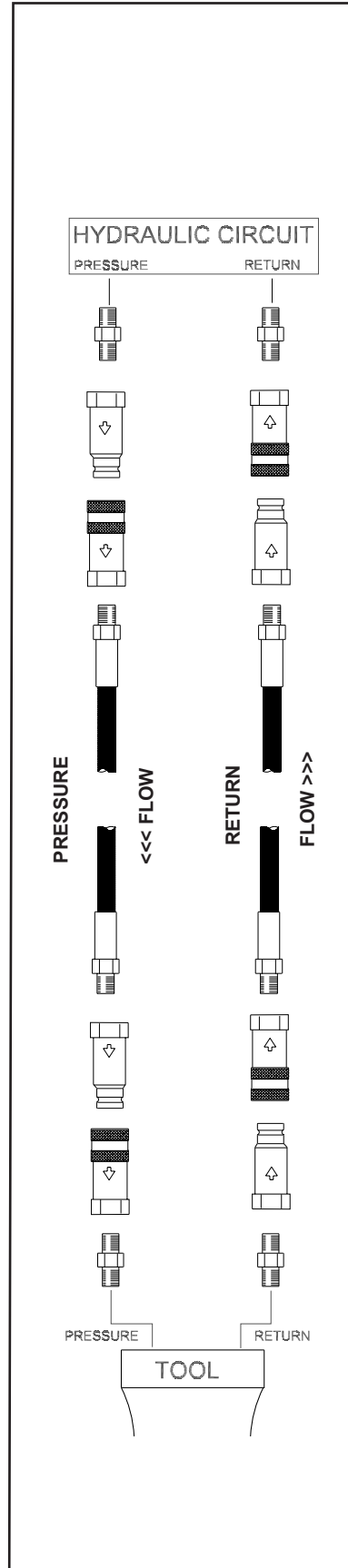

Figure 1. Typical Hose Connections

HTMA REQUIREMENTS

HTMA / EHTMA REQUIREMENTS

HTMA





HYDRAULIC SYSTEM REQUIREMENTS

TOOL TYPE

	TYPE I	TYPE II	TYPE RR	TYPE III
Flow Range	4-6 gpm (15-23 lpm)	7-9 gpm (26-34 lpm)	9-10.5 gpm (34-40 lpm)	11-13 gpm (42-49 lpm)
Nominal Operating Pressure (at the power supply outlet)	1500 psi (103 bar)	1500 psi (103 bar)	1500 psi (103 bar)	1500 psi (103 bar)
System relief valve setting (at the power supply outlet)	2100-2250 psi (145-155 bar)	2100-2250 psi (145-155 bar)	2200-2300 psi (152-159 bar)	2100-2250 psi (145-155 bar)
Maximum back pressure (at tool end of the return hose)	250 psi (17 bar)	250 psi (17 bar)	250 psi (17 bar)	250 psi (17 bar)
Measured at a max. fluid viscosity of: (at min. operating temperature)	400 ssu* (82 centistokes)	400 ssu* (82 centistokes)	400 ssu* (82 centistokes)	400 ssu* (82 centistokes)
Temperature: Sufficient heat rejection capacity to limit max. fluid temperature to: (at max. expected ambient temperature)	140° F (60° C)	140° F (60° C)	140° F (60° C)	140° F (60° C)
Min. cooling capacity at a temperature difference of between ambient and fluid temps NOTE: Do not operate the tool at oil temperatures above 140° F (60° C). Operation at higher temperatures can cause operator discomfort at the tool.	3 hp (2.24 kW) 40° F (22° C)	5 hp (3.73 kW) 40° F (22° C)	6 hp (5.22 kW) 40° F (22° C)	7 hp (4.47 kW) 40° F (22° C)
Filter Min. full-flow filtration Sized for flow of at least: (For cold temp. startup and max. dirt-holding capacity)	25 microns 30 gpm (114 lpm)	25 microns 30 gpm (114 lpm)	25 microns 30 gpm (114 lpm)	25 microns 30 gpm (114 lpm)
Hydraulic fluid Petroleum based (premium grade, anti-wear, non-conductive) Viscosity (at min. and max. operating temps)	100-400 ssu*	100-400 ssu* (20-82 centistokes)	100-400 ssu*	100-400 ssu*
NOTE: When choosing hydraulic fluid, the expected oil temperature extremes that will be experienced in service determine the most suitable temperature viscosity characteristics. Hydraulic fluids with a viscosity index over 140 will meet the requirements over a wide range of operating temperatures.				
*SSU = Saybolt Seconds Universal				

EHTMA HYDRAULIC SYSTEM REQUIREMENTS

CLASSIFICATION

					
Flow Range	3.5-4.3 gpm (13.5-16.5 lpm)	4.7-5.8 gpm (18-22 lpm)	7.1-8.7 gpm (27-33 lpm)	9.5-11.6 gpm (36-44 lpm)	11.8-14.5 gpm (45-55 lpm)
Nominal Operating Pressure (at the power supply outlet)	1870 psi (129 bar)	1500 psi (103 bar)	1500 psi (103 bar)	1500 psi (103 bar)	1500 psi (103 bar)
System relief valve setting (at the power supply outlet)	2495 psi (172 bar)	2000 psi (138 bar)	2000 psi (138 bar)	2000 psi (138 bar)	2000 psi (138 bar)

NOTE: These are general hydraulic system requirements. See tool specification page for tool specific requirements

OPERATION

WRENCH TORQUE INFORMATION

FACTORS THAT AFFECT TORQUE

An impact wrench is a rotary hammer that impacts the head of a bolt or nut. It does not apply a slow steady torque as a standard torque wrench. Therefore, several factors affect the result of torque when using impact wrenches:

1. **LONG BOLTS.** Long bolts having high-friction threads with lubrication under the bolt head or associated nut can twist when impacted, then untwist before the next impact. This will especially happen if there is low friction between the bolt head or nut and the mating surface.
2. **HEAVY, LOOSE OR MULTIPLE ADAPTERS.** Heavy, loose or multiple adapters between the wrench and socket can dissipate the intensity of the impact to the bolt head or nut.
3. **AMOUNT OF IMPACT.** Maximum torque results can be obtained by allowing continuous impacting of the socket against the bolt head or nut for at least 10 seconds.
4. **HYDRAULIC FLOW RATE.** If the flow rate to the tool is too low, the hammer (or impact) speed is reduced. If the flow is correct, a change in the relief pressure does not affect the impact force. Poorly designed hydraulic circuits can result in lower flow rates and reduced impact speeds when pressure is required during impacting.

BOLT GRADE AND THREAD RECOMMENDATIONS

Allowable bolt torque is limited by both bolt thread diameter and grade of steel in the bolt. The IW12 Impact Wrench is recommended for use on the following bolt grade and thread sizes:

SAE Grade 2	1 to 1-1/2 inch / 25/38 mm
SAE Grade 5	3/4 to 1-1/4 inch / 19-32 mm
SAE Grade 8	5/8 to 1 inch / 16-25 mm

PREOPERATION PROCEDURES

CHECK POWER SOURCE

1. Using a calibrated flow meter and pressure gauge, check that the hydraulic power source develops a flow of 4–12 gpm/15–45 lpm at 1000–2000 psi/70–140 bar.
2. Make certain that the hydraulic power source is equipped with a relief valve set to open at 2100 psi/145 bar minimum.

CONNECT HOSES

1. Wipe all hose couplers with a clean, lint-free cloth before making connections.
2. Connect hoses from the hydraulic power source to the tool fittings or quick disconnects. It is good practice to connect the return hose first and disconnect it last to minimize or eliminate trapped pressure within the wrench.

WARNING

Always use sockets and accessories designed for impact type applications. **DO NOT USE STANDARD SOCKETS OR ACCESSORIES. THESE CAN CRACK OR FRACTURE DURING OPERATION.**

3. Observe the flow indicators stamped on the main body assembly and the hose couplers to ensure that the flow is in the proper directions. The female couple on the tools “IN” port is the inlet (pressure) coupler.

NOTE:

If the uncoupled hoses are left in the sun, pressure increase within the hoses can make them difficult to connect. Whenever possible, connect the free ends of hoses together.

WRENCH OPERATION

The IW12 is designed for 3/4-inch square sockets and accessories. Adapter part number 06790 or equivalent will permit the use of 5/8-inch quick change drive attachments.

Normal applications include installation or removal of fasteners requiring torque in the range of 300–1200 lb/407–1627 Nm and auger bit wood boring. **DO NOT** use the wrench as a hammer drill for metal drilling.

During normal operation it is common to see some grease leakage from around the anvil during hard use. Refer to the *IW12 Service Manual* for the correct lubrication procedures.

1. Observe all Safety Precautions.
2. Move the hydraulic circuit control valve to the “ON” position to operate the wrench.

3. Select the direction of impact desired using the rotary reversing valve located on the left side of the wrench. To select clockwise direction, move the lever toward the front (drive end) of the wrench. To select counterclockwise direction, move the lever to the rear (handle end) of the wrench.

NOTE:

To more accurately tighten bolts, lubricate threads, check with a torque wrench and duplicate time of impacting for other bolts of the same length and thread size.

4. Squeeze the trigger to activate the wrench.
5. Release the trigger to stop the wrench.

COLD WEATHER OPERATION

If the wrench is to be used during cold weather, preheat the hydraulic fluid at low engine speed. When using the normally recommended fluids, fluid temperature should be at or above 50 °F/10 °C (400 ssu/82 centistokes) before use.

Damage to the hydraulic system or wrench can result from use with fluid that is too viscous or too thick.

POST OPERATION UNDERWATER MODELS ONLY

The wrench impact mechanism must be cleaned and greased with waterproof grease after every day of use. The main housing valve and motor are sealed and do not require maintenance unless they are malfunctioning.

Remove, clean, grease and assemble the impact mechanism as described in the *IW12 Service Manual*.

TOOL PROTECTION & CARE

NOTICE

In addition to the Safety Precautions found in this manual, observe the following for equipment protection and care.

- Make sure all couplers are wiped clean before connection.
- The hydraulic circuit control valve must be in the “OFF” position when coupling or uncoupling hydraulic tools. Failure to do so may result in damage to the quick couplers and cause overheating of the hydraulic system.
- Always store the tool in a clean dry space, safe from damage or pilferage.
- Make sure the circuit PRESSURE hose (with male quick disconnect) is connected to the “IN” port. The circuit RETURN hose (with female quick disconnect) is connected to the opposite port. Do not reverse circuit flow. This can cause damage to internal seals.
- Always replace hoses, couplings and other parts with replacement parts recommended by Stanley Hydraulic Tools. Supply hoses must have a minimum working pressure rating of 2500 psi/172 bar.
- Do not exceed the rated flow (see Specifications) in this manual for correct flow rate and model number. Rapid failure of the internal seals may result.
- Always keep critical tool markings, such as warning stickers and tags legible.
- Tool repair should be performed by experienced personnel only.
- Make certain that the recommended relief valves are installed in the pressure side of the system.
- Do not use the tool for applications for which it was not intended.

TROUBLESHOOTING

If symptoms of poor performance develop, the following chart can be used as a guide to correct the problem. When diagnosing faults in operation of the wrench, always check that the hydraulic power source is supplying the correct hydraulic flow and pressure to the tool as listed in the following table. Use a flow meter known to be accurate. Check the flow with the hydraulic fluid temperature at least 80 °F/27 °C.

PROBLEM	CAUSE	SOLUTION
Low performance or impact.	Incorrect hydraulic flow.	Check that the hydraulic power source is producing 4–12 gpm/15–45 lpm at 1000–2000 psi/70–140 bar.
	Defective quick disconnects.	Check each quick disconnect.
	Worn impact mechanism.	Repair or replace the impact mechanism. See Service Mechanism Removal Cleaning and Installation procedure to extend mechanism life.
	Hammer pins broken.	Replace with integral frame (with pins). Check relief adjustment screw setting. Job may require a larger wrench.
	Incorrect grease or periodic maintenance of the impact mechanism is not being performed.	See Service Manual.
	Spools incorrectly installed.	Valve(s) incorrectly reassembled. See Service Manual.
	Sockets or adapters too heavy or loose.	Use the correct impact type sockets or adapters.
	Long bolt with lubricated head.	Lubricate threads only.
Wrench runs too fast. Impact mechanism or screws broken.	Incorrect hydraulic flow (too high).	Check that hydraulic power source is producing 4-12 gpm/15-45 lpm at 1000-2000 psi/70-140 bar.
	Supply and return hoses reversed.	Install hoses correctly. Refer to Operation section in this manual.
	Relief sleeve or spring damaged.	Remove and replace spool assembly.
	Adjusting screw is in too far.	Adjust correctly.
Grease leaks at anvil busing, wrench warm.	Hard duty cycle and heat forces grease out.	Normal unless greasing instructions in Service Manual are not followed.
Grease leaks at anvil bushing, wrench cold.	Main shaft O-ring leaking.	Replace as required.
Oil leak at motor cap face.	Fasteners loose.	Tighten to recommended torque.
	Face O-ring worn or missing.	Replace as required.
	Motor cap/main housing damaged.	Replace as required.
Oil leaks at reversing spool.	Damaged O-rings.	Replace as required. Check Service Manual to avoid cutting O-rings on cross holes in the spool bore.
	Wrong hydraulic fluid. Circuit too hot.	Refer to Operation section for correct fluid/circuit specifications.

SPECIFICATIONS

Drive Size	3/4-inch Square Drive, 5/8-inch Hex Quick Change
Weight	14 lbs/6 kg
Overall Length	9-1/2-inch/24 cm
Width	4-inch/10 cm
Pressure Range.....	1000-2000 psi/70–140 bar
Flow Range	4–12 gpm/15–45 lpm
Optimum Flow	5–10 gpm/20–38 lpm
System Type.....	Open and Closed Center, HTMA Type II or III
Porting	8 SAE O-ring
Output Speed (free spin)	2000 rpm at 5 gpm/19 lpm
Input Speed	1200 Impacts per Minute
Connect Size and Type	3/8-inch Male Pipe Adapter
Torque.....	250–1200 ft. lb/340–1632 Nm

SOUND AND VIBRATION DECLARATION

Test conducted on 1212140, S/N 121610100 operated at standard 10 gpm input	
Measured A-weighted sound power level, Lwa (ref. 1pW) in decibels	108 dBA
Uncertainty, Kwa, in decibels	3 dBA
Measured A-weighted sound pressure level, Lpa (ref. 20 µPa) at operator's position, in decibels	95 dBA
Uncertainty, Kpa, in decibels	3 dBA
Values determined according to noise test code given in ISO 15744, using the basic standard ISO 3744	
NOTE: The sum of a measured noise emission value and its associated uncertainty represents an upper boundary of the range of values which is likely to occur in measurements.	
Declared vibration emission value in accordance with EN 12096	
Measured vibration emission value (Main Handle): a	10.9 m/sec ²
Uncertainty: K	1.2 m/sec ²
Measured vibration emission value (Assist Handle): a	11.2 m/sec ²
Uncertainty: K	1.2 m/sec ²
Values determined according to ISO 28927-2, ISO 5349-1,2	

ACCESSORIES

Description	Part Number
3/4-inch Square Anvil to 3/4-inch Jacobs Chuck	01857
7/16-inch Hex Shank × 1/2-inch Square Male Adapter.....	05117
5/8-inch Hex Shank × 1/2-inch Square Male Adapter.....	05080
3/4-inch Square Anvil to 5/8-inch Hex Quick Change Adapter	06790

AUGER DRILL BITS – LINEMAN'S STYLE

5/8-inch Hex Shank use with Hex Adapter 06790

5/8 Hex Pole Bit, 9/16 × 18 × 22 Overall Length	27845
5/8 Hex Pole Bit, 13/16 × 18 × 22 Overall Length	27847
Assist Handle Kit	71706

IW12 STD IMPACT MECHANISM ILLUSTRATION

CLEAN, APPLY 242 LOCTITE®, AND TORQUE (8) CAPSCREWS TO 28–30 FT LB / 37.9–40.6 NM USING THE TORQUE PATTERN SHOWN AT THE RIGHT

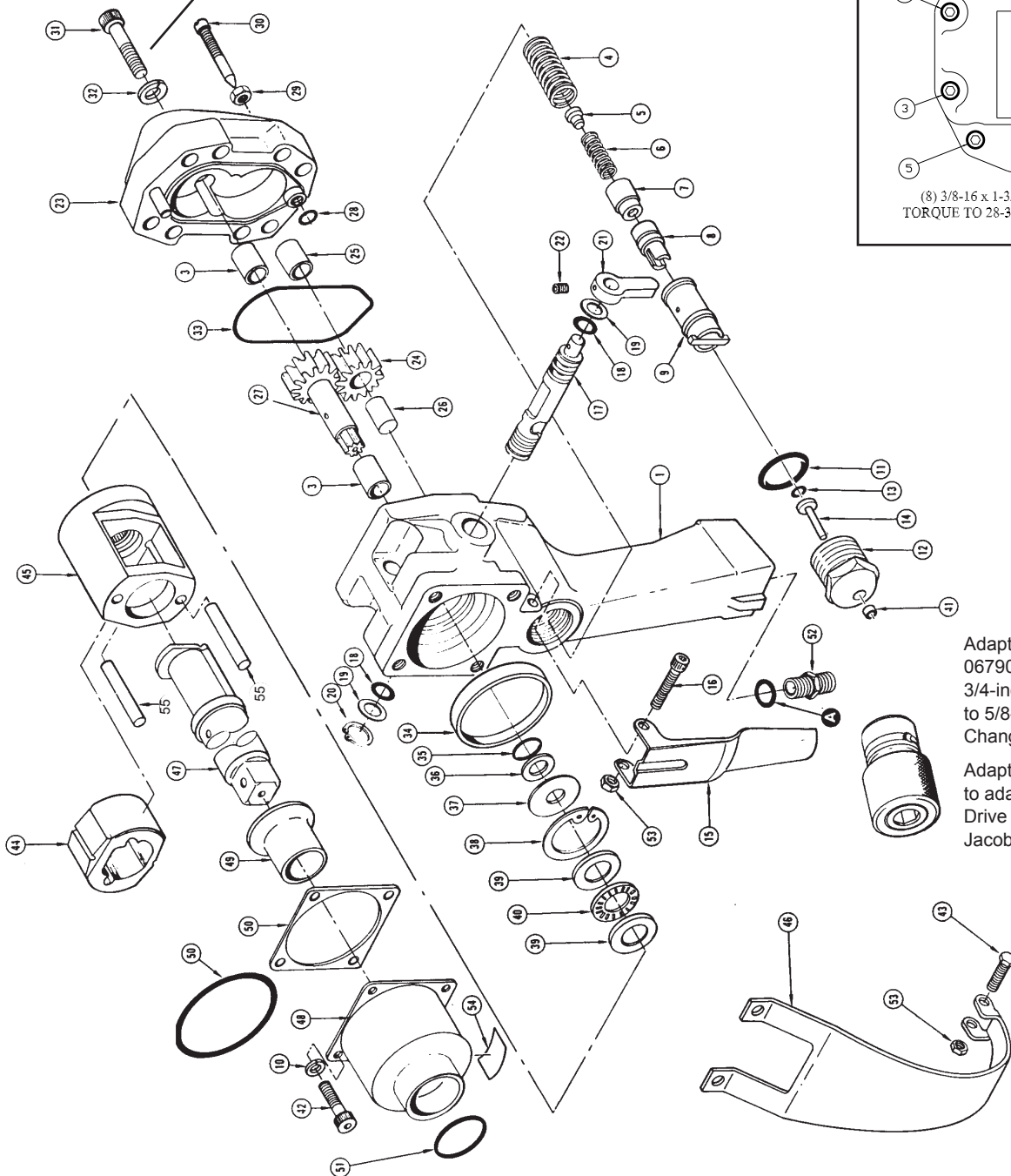
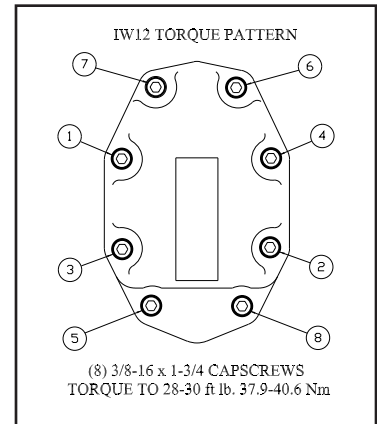

Adapter Part Number 06790, used to adapt 3/4-inch Square Drive to 5/8-inch Hex Quick Change.

Adapter P/N 01857, used to adapt 3/4-inch Square Drive to 3/4-inch 3-Jaw Jacobs Chuck.

PARTS LIST

STANDARD IMPACT MECHANISM PARTS LIST

ITEM NO.	PART NO.	QTY	DESCRIPTION
1	07999	1	MAIN HOUSING ASSY – INCL ITEM 3 ALSO INCL BALL STOP 19454 AND STEEL BALL 51185 NOT PICTURED
3	08014	2	DU BUSHING – GARLOCK 14DU12
4	07988	1	SPRING
5	07982	1	SPRING REST
6	07985	1	SPRING
7	07993	1	RELIEF POPPET
8	07986	1	RELIEF SEAT
9	73046	1	VALVE SPOOL
10	00145	4	LOCKWASHER, 5/16-IN.
	00231	4	LOCKWASHER, 5/16-IN. (STAINLESS STEEL)
11	06533	1	O-RING *
12	22063	1	SPOOL CAP (UNDERWATER)
13	00026	1	O-RING *
14	23678	1	HEADED PUSH PIN (UNDERWATER)
15	07996	1	TRIGGER
	12283	1	TRIGGER (UNDERWATER)
	28536	1	TRIGGER (CE)
16	00025	1	CAPSCREW, 10-24 × 1-3/4 HEX SOCKET HD
	00786	1	CAPSCREW, 10-24 × 1-3/4 HEX SOCKET HD (STAINLESS STEEL)
17	08002	1	REVERSING SPOOL
18	01211	2	O-RING *
19	08015	2	BACK-UP RING*
20	08016	1	RETAINING RING
21	04939	1	LEVER
22	00720	1	SETSCREW, 1/4-20 × 3/8
	00580	1	SETSCREW, 1/4-20 × 1/4 (STAINLESS STEEL, UNDERWATER)
23	07997	1	MOTOR CAP ASSY – INCL ITEM 3
24	07989	1	IDLER GEAR ASSY – INCL ITEM 25
25	07978	1	IDLER GEAR BUSHING
26	07991	1	IDLER SHAFT
27	08001	1	MAIN SHAFT
28	00717	1	O-RING *
29	00429	1	NUT, 5/16-18
	09277	1	NUT, 5/16-18 (STAINLESS STEEL, UNDERWATER)
30	19453	1	RELIEF ADJUSTMENT SCREW
31	00682	8	CAPSCREW, 3/8-16 × 1-3/4 HEX SOCKET HD (STAINLESS STEEL, UNDERWATER)
	01870	8	CAPSCREW, 3/8-16 × 1-3/4 HEX SOCKET HD

ITEM NO.	PART NO.	QTY	DESCRIPTION
32	01459	8	LOCKWASHER, 3/8
	00812	8	LOCKWASHER, 3/8, (STAINLESS STEEL, UNDERWATER)
33	08023	1	O-RING *
34	07980	1	PILOT RING
35	08017	1	O-RING *
36	09396	1	BACK-UP RING *
37	07987	1	BACK-UP WASHER
38	00166	1	RETAINING RING
39	08019	2	THRUST RACE
40	08020	1	THRUST BEARING
41	22064	1	ROD WIPER (UNDERWATER) *
42	02685	4	CAPSCREW, 5/16-18 × 7/8 HEX SOCKET HD
	01870	4	CAPSCREW, 3/8-16 × 1-3/4 HEX SOCKET HD (STAINLESS STEEL, UNDERWATER)
43	12287	1	CAPSCREW, 10-24 × 1 HEX SOCKET HD (STAINLESS STEEL, UNDERWATER)
44	08067	1	HAMMER
45	19456	1	HAMMER FRAME ASSY – INCL HAMMER PINS
46	12285	1	TRIGGER GUARD (UNDERWATER)
47	08070	1	ANVIL – 3/4 IN. SQUARE DRIVE
	08070	1	ANVIL (UNDERWATER) MODEL IW1234001
48	08071	1	HAMMER CASE ASSY – INCL ITEM 49
	12785	1	HAMMER CASE ASSY (UNDERWATER) MODEL IW1234001
49	08072	1	HAMMER CASE BUSHING (LAND) MODEL
	13694	1	HAMMER CASE BUSHING (UNDERWATER MODEL)
50	00149	1	O-RING * (LAND & UNDERWATER)
51	00294	1	O-RING * (UNDERWATER)
52	00936	2	ADAPTER, 1/2 SAE TO 3/8 NPT MALE
53	06971	2	LOCKNUT, 10-24
54	03693	1	DECAL, CLOSED-CENTER
55	08069	2	HAMMER PINS (INCLUDED WITH ITEM 45)
	08073	1	SEAL KIT – LAND MODEL
	13695	1	SEAL KIT – UNDERWATER MODEL

* Part of Seal Kit

HEAVY DUTY IMPACT MECHANISM ILLUSTRATION

CLEAN, APPLY
242 LOCTITE®,
AND TORQUE (8)
CAPSCREWS TO
28–30 FT LB / 37.9–
40.6 NM USING THE
TORQUE PATTERN
SHOWN AT THE
BOTTOM LEFT

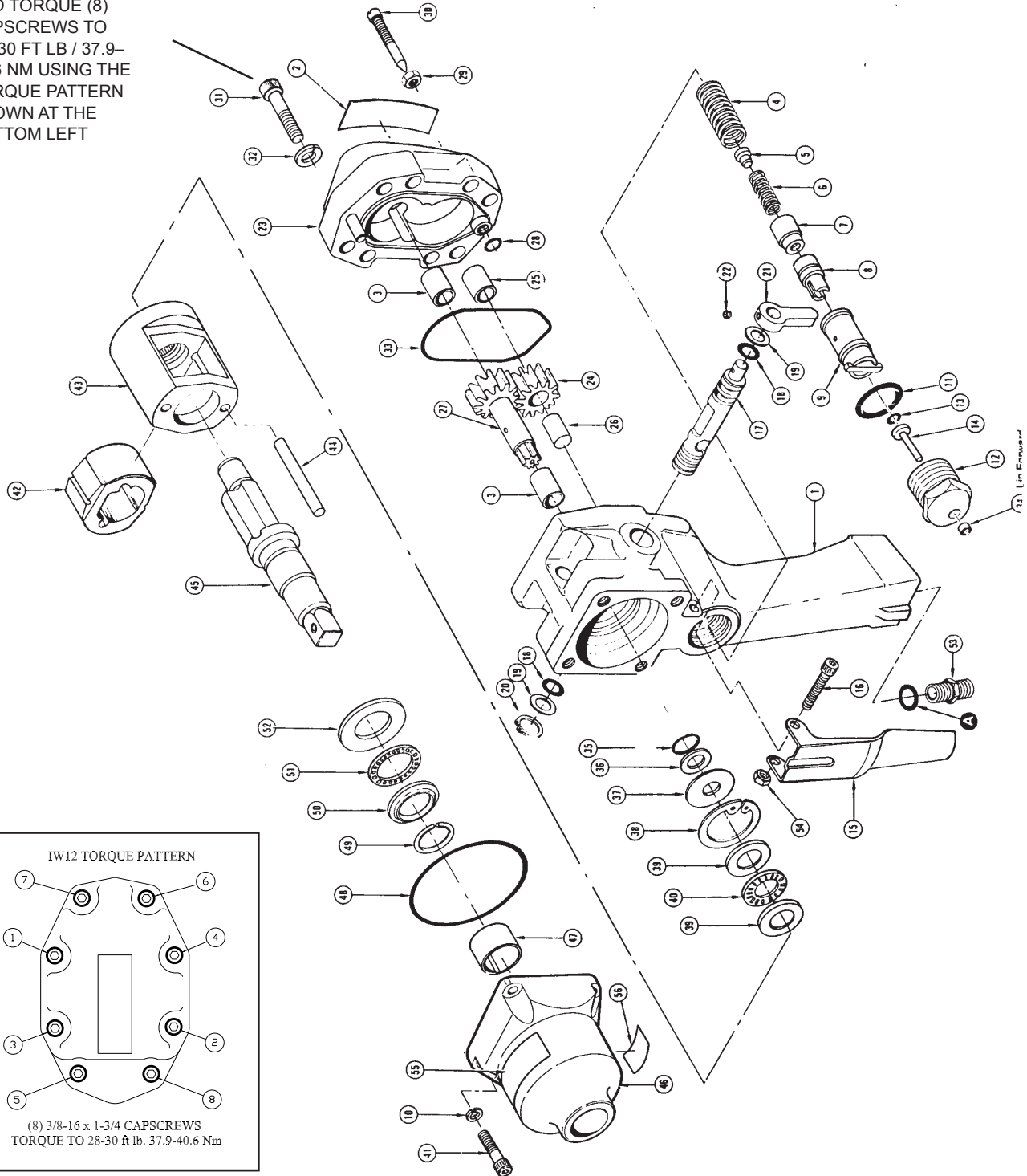

PARTS LIST

HEAVY DUTY IMPACT MECHANISM PARTS LIST

ITEM NO.	PART NO.	QTY	DESCRIPTION
1	07999	1	MAIN HOUSING ASSY(INCL ITEM 3) ALSO INCL BALL STOP 19454 AND STEEL BALL 51185 NOT PICTURED
2	08012	1	NAME TAG
3	08014	2	DU BUSHING – GARLOCK 14DU12
4	07988	1	SPRING
5	07982	1	SPRING REST
6	07985	1	SPRING
7	07993	1	RELIEF POPPET
8	07986	1	RELIEF SEAT
9	73046	1	VALVE SPOOL
10	00145	4	LOCKWASHER, 5/16-IN.
11	06533	1	O-RING *
12	22063	1	SPOOL CAP (UNDERWATER)
13	00026	1	O-RING *
14	23678	1	HEADED PUSH PIN
15	07996	1	TRIGGER
16	00025	1	CAPSCREW, 10-24 × 1-3/4 HEX SOCKET HD
17	08002	1	REVERSING SPOOL
18	01211	2	O-RING *
19	08015	2	BACK-UP RING *
20	08016	1	RETAINING RING
21	04939	1	LEVER
22	00720	1	SETSCREW, 1/4-20 × 3/8
23	07997	1	MOTOR CAP ASSY – INCL ITEM 3
24	07989	1	IDLER GEAR ASSY – INC. ITEM 25
25	07978	1	IDLER GEAR BUSHING
26	07991	1	IDLER SHAFT
27	08001	1	MAIN SHAFT
28	00717	1	O-RING *
29	00429	1	NUT, 5/16-18
30	19453	1	RELIEF ADJUSTMENT SCREW
31	00682	8	CAPSCREW, 3/8-16 × 1-3/4 HEX SOCKET HD (STAINLESS STEEL, UNDERWATER)
32	01459	8	LOCKWASHER, 3/8
33	08023	1	O-RING *
34	22064	1	WIPER *
35	08017	1	O-RING *
36	09396	1	BACK-UP RING *
37	07987	1	BACK-UP WASHER
38	00166	1	RETAINING RING
39	08019	2	THRUST RACE
40	08020	1	THRUST BEARING

ITEM NO.	PART NO.	QTY	DESCRIPTION
41	02685	4	CAPSCREW, 5/16-18 × 7/8 HEX SOCKET HD
42	08067	1	HAMMER
43	20257	1	HAMMER FRAME
44	08069	2	HAMMER PIN
45	22728	1	ANVIL – 3/4 IN. SQUARE DRIVE STANDARD
	20263	1	ANVIL – 3/4 IN. SQUARE DRIVE 12-IN. EXTND
46	29087	1	HAMMER CASE ASSY
	22729	1	IMPACT MECHANISM – HEAVY DUTY
47	20258	1	HAMMER CASE BUSHING (LAND)
	35445	1	HAMMER CASE BUSHING (UNDERWATER)
48	00149	1	O-RING (LAND & UNDERWATER) *
49	20262	1	RETAINING RING
50	21408	1	THRUST BEARING RACE
51	09878	1	THRUST BEARING
52	20259	1	RETAINER
53	00936	2	ADAPTER, 1/2 SAE TO 3/8 NPT MALE
54	06971	2	LOCKNUT, 10-24
55	17275	1	DECAL, GPM
56	03693	1	DECAL, CLOSED-CENTER
	06345	2	PLASTIC PLUG (NOT ILLUSTRATED)
	08073	1	SEAL KIT – LAND MODEL
	22729	1	IMPACT MECHANISM – HEAVY DUTY
	35451	1	IMPACT MECHANISM – HEAVY DUTY U/W

* Part of Seal Kit

STANDARD IMPACT & HEAVY DUTY IMPACT MECHANISMS IN DETAIL

When ordering Impact Mechanism parts, first determine which mechanism you have by visually inspecting the following two parts indicated by the arrows (A: Hammer Case, B: Anvil).

STANDARD MECHANISM

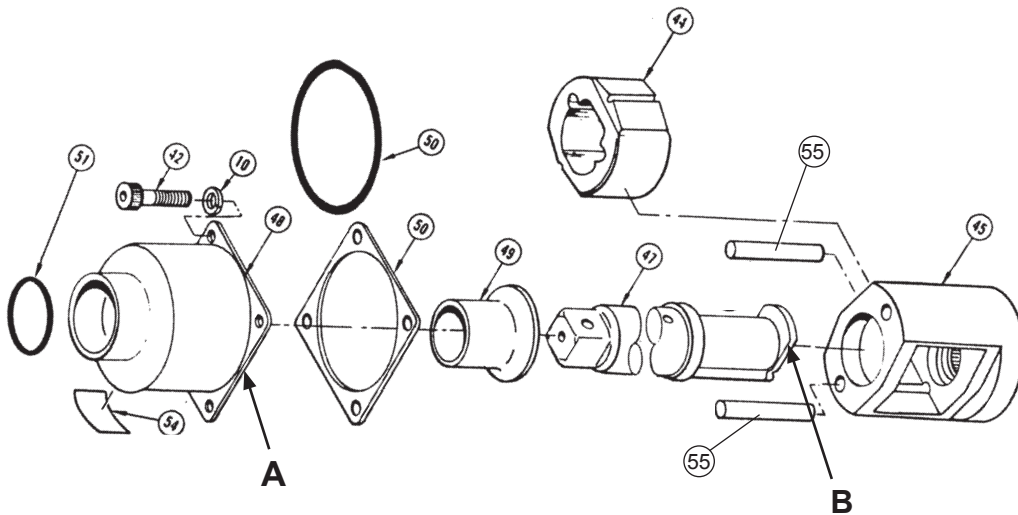

HEAVY DUTY MECHANISM

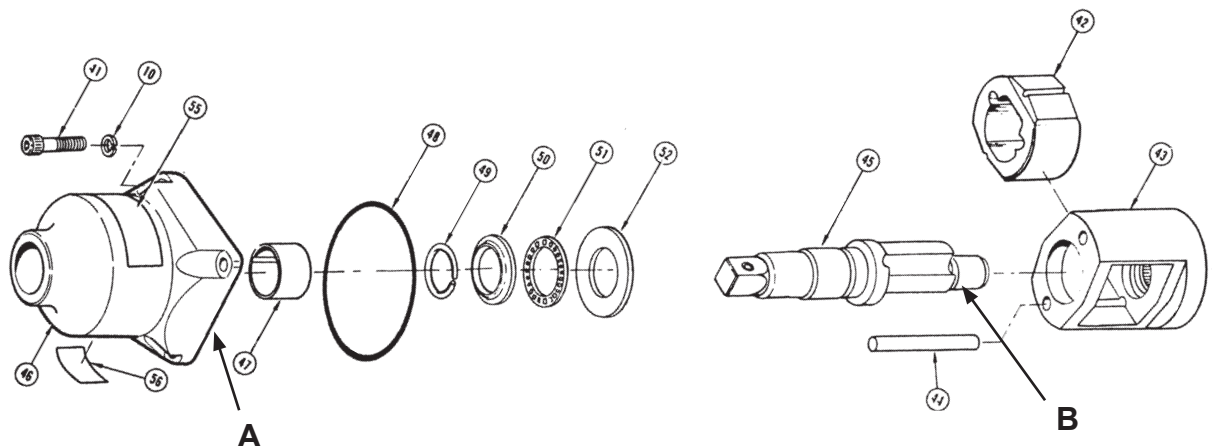

Note the difference in the Hammer Case (A) when ordering.

NOTE: The Anvil (B) for a Standard Mechanism has a tab on one end, while the Heavy Duty Anvil has a round diameter on one end.



Stanley Hydraulic Tools
3810 SE Naef Road
Milwaukie, Oregon 97267-5698 USA
(503) 659-5660 / Fax (503) 652-1780
www.stanleyhydraulic.com