



AURORA[®]

Photovoltaic Inverters

INSTALLATION AND OPERATOR'S MANUAL

REVISION TABLE

| Document Revision | Author | Date | Change Description |
|-------------------|--------|------|--------------------|
| 1.0 | | | First release |
| | | | |



SAVE THESE INSTRUCTIONS !



IMPORTANT SAFETY INSTRUCTIONS

POWER-ONE: Reproduction and disclosure, even partially, of the contents of this manual are strictly forbidden without prior authorization of Power-One.

IMPORTANT SAFETY INSTRUCTIONS

This manual contains important safety and operational instructions that must be accurately understood and followed during the installation and maintenance of the equipment.

To reduce the risk of electrical shock hazards, and to make sure the equipment is safely installed and commissioned, special safety symbols are used in this manual to highlight potential safety risks and important safety information. The symbols are:



WARNING: the paragraphs highlighted by this symbol contain processes and instructions that must be absolutely understood and followed to avoid potential danger to people.



NOTE: the paragraphs highlighted by this symbol contain processes and instructions that must be rigorously understood and followed to avoid potential damage to the equipment and negative results.

The equipment is provided with several labels, some of them with a yellow background, which are related to safety issues.

Make sure to read the labels and fully understand them before installing the equipment.

The labels utilize the following symbols:

| | |
|--|---|
| | Equipment grounding conductor (Main grounding protective earth, PE) |
| | Alternate Current (AC) value |
| | Direct Current (DC) value |
| | Phase |
| | Grounding (Earth) |

USEFUL INFORMATION AND SAFETY STANDARD

FOREWORD

- The installation of Aurora must be performed in full compliance with national and local standards and regulations
- AURORA has no spare parts to replace.
For any maintenance or repair please contact the nearest authorized repair center. Please contact your reseller if you need to know the nearest authorized repair center.
- Read and understand all the instructions contained in this manual and become familiar with the safety symbols in the relevant paragraphs before you install and commission the equipment
- The connection to the distribution grid must be done only after receiving approval from the distribution utility as required by national and state interconnection regulations, and can be done only by qualified personnel.
- Cover the photovoltaic panels with dark opaque sheets before they are connected to avoid any chance of high voltages to appear at the connecting cable terminations.

GENERAL

During inverter operation, some parts can be powered, some not properly insulated and, in some cases, some parts can move or rotate, or some surfaces be hot.

Unauthorized removal of the necessary protections, improper use, wrong installation or wrong operation may lead to serious damage to people and objects.

Transport, handling, installation, commissioning and maintenance must be performed by qualified and trained personnel (all accident prevention rules in force in the user's country must be observed ! !!).

According to these basic safety rules, qualified and trained people have skills for the assembling, start-up and operation of the product, as well as the necessary requirements and qualifications to perform such operations.

ASSEMBLY

Devices shall be assembled and cooled according to the specifications mentioned in the corresponding documents.

In particular, during transport and handling, parts shall not be bent and/or the insulation distances shall not be changed. There should be no contact between electronic parts and connection terminals.

Electrical parts must not be mechanically damaged or destroyed (potential health risk).

ELECTRICAL CONNECTION

With the inverter powered, comply with all prevailing national regulations on accidents prevention.

Electrical connections shall be carried out in accordance with the applicable regulations, such as conductor sections, fuses, PE connection.

OPERATION

Systems with inverters shall be provided with further control and protective devices in compliance with the corresponding prevailing safety rules, such as those relating to the compliance with technical equipment, accident-preventing regulations, etc. Any calibration change shall be made using the operational software. Once the inverter has been disconnected from the power grid, powered parts and electrical connections shall not be touched as some capacitors could be charged. Comply with all corresponding marks and symbols present on each device. During operation, make sure that all covers and doors are closed.

MAINTENANCE AND SERVICE

Comply with manufacturer's recommendations.

SAVE ALL DOCUMENTS IN A SAFE PLACE !

PVI-6000-OUTD-AU
PVI-6000-OUTD-S-AU
PVI-6000-OUTD-DS-AU

This document applies to the above-mentioned inverters, only.

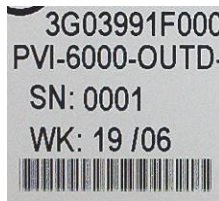

Fig.1 Name plate

The name plate affixed to the inverter provides the following information:

- 1) Manufacturing Part Number
- 2) Model Number
- 3) Serial Number
- 4) Week/Year of Manufacture

CONTENTS:

1. FOREWORD 11

 1.1. PHOTOVOLTAIC ENERGY 11

2. DESCRIPTION OF THE SYSTEM..... 12

 2.1. KEY ELEMENTS OF A PHOTOVOLTAIC SYSTEM: “STRINGS” AND “ARRAYS” . 12

 2.2. AVAILABLE VERSIONS 15

 2.3. DATA TRANSMISSION AND CHECK 17

 2.4. AURORA TECHNICAL DESCRIPTION 17

 2.5. PROTECTIVE DEVICES 19

 2.5.1 *Anti-Islanding* 19

 2.5.2 *Panel Ground Fault* 19

 2.5.3 *Further Protective Devices* 19

3. INSTALLATION 20

 3.1. PACKAGE INSPECTION 20

 3.2. INSPECTING PACKAGE CONTENTS 21

 3.3. SELECTING THE PLACE OF INSTALLATION 22

 3.4. WALL MOUNTING 23

 3.5. BEFORE PERFORMING THE ELECTRICAL CONNECTIONS 26

 3.6. ELECTRICAL CONNECTIONS 30

 3.7. HOW TO ACCESS THE INTERNAL TERMINAL BOARDS THROUGH THE FRONT
 PANEL 34

 3.8. REPLACING THE CR2032 LITHIUM BATTERY 34

 3.9. REPLACING THE MEMORY 35

4. START-UP 37

5. MONITORING AND DATA TRANSMISSION..... 38

 5.1. USER’S INTERFACE MODE 38

 5.2. AVAILABLE DATA 40

 5.2.1 *Real-time operational data* 40

 5.2.2 *Internally logged data* 41

 5.3. LED INDICATORS 42

 5.4. MESSAGES AND ERROR CODES 47

 5.5. LCD DISPLAY 50

 5.5.1 *Connection of system to the grid* 50

 5.5.2 *Error messages* 51

| | |
|---|-----------|
| 5.5.3 First phase - electric parameter check..... | 53 |
| 5.5.4 Main menu..... | 57 |
| 5.5.5 Statistics | 58 |
| 5.5.5.1 Lifetime | 58 |
| 5.5.5.2 Partial | 59 |
| 5.5.5.3 Today | 59 |
| 5.5.5.4 Last 7 days | 60 |
| 5.5.5.5 Last Month | 60 |
| 5.5.5.6 Last 30 Days | 60 |
| 5.5.5.7 Last 365 Days | 60 |
| 5.5.5.8 User period..... | 61 |
| 5.5.6 Setting..... | 62 |
| 5.5.6.1 Address | 63 |
| 5.5.6.2 Display Set | 63 |
| 5.5.6.3 Service..... | 64 |
| 5.5.6.4 New Password..... | 64 |
| 5.5.6.5 Cash..... | 64 |
| 5.5.6.6 Time | 65 |
| 5.5.6.7 Language | 65 |
| 5.5.6.8 START Voltage | 65 |
| 5.5.6.9 Autotest | 65 |
| 5.5.6.10 Alarm | 66 |
| 5.5.6.11 Remote Control | 67 |
| 5.5.6.12 UV Prot.time | 68 |
| 5.5.6.13 MPPT scan | 68 |
| 5.5.6.14 Scan Interval | 68 |
| 5.5.7 Info | 69 |
| 6. DATA CHECK AND COMMUNICATION | 71 |
| 6.1. CONNECTION THROUGH RS-485 SERIAL PORT OR RJ12 CONNECTORS | 71 |
| 6.1.1 RS-485 serial port | 71 |
| 6.1.2 RJ12 connectors | 72 |
| 6.1.3 Daisy chain | 73 |
| 6.2. SERIAL CONNECTION WITH USB PORT | 75 |
| 6.3. MEASUREMENT ACCURACY | 76 |

7. TROUBLESHOOTING..... 78

8. TECHNICAL FEATURES..... 80

8.1. INPUT VALUES 80
8.2. OUTPUT VALUES 83
8.3. GRID PROTECTION CHARACTERISTICS 83
8.4. GENERAL CHARACTERISTICS..... 84
8.5. POWER DERATING..... 85

1. FOREWORD

This document contains a technical description of AURORA photovoltaic inverter so as to provide the installer and user all the necessary information about installation, operation and use of AURORA.

1.1. PHOTOVOLTAIC ENERGY

Industrialized countries (greater energy consumers) have been experimenting energy-saving methods and reduced pollutant levels for many years thanks to the energy-conversion process. This may be possible through a shrewd and rational consumption of well-known resources, and also by looking for new forms of clean and not exhaustible energy.

Regenerating sources of energy are fundamental to solve this problem. Under these circumstances, solar energy exploitation to generate electrical (photovoltaic) energy is becoming more and more important worldwide.

Photovoltaic energy, in any case, is of great advantage to the environment because the radiated energy we receive from the sun is transformed directly into electrical energy without any combustion process and without producing any pollution.

2. DESCRIPTION OF THE SYSTEM

The AURORA inverter is capable of feeding a power grid using the power generated by photovoltaic panels.

Photovoltaic panels transform the sun-radiated energy into electrical energy in the form of direct (DC) current (through a photovoltaic field, also known as PV generator). In order to utilize this energy and feed it back to the distribution grid, this energy shall be turned into alternating (AC) current. Aurora does this conversion, also known as DC to AC inversion, in a very efficient way, without using rotating parts but just static power electronic devices.

When used in parallel with the grid, the alternate current generated by the inverter is directly fed to the domestic distribution circuit, which is in its turn also connected to the public power distribution grid.

The solar energy system can thus feed all the connected users, such as lighting devices, household appliances, etc.

When the photovoltaic system is not generating sufficient energy, the power required to ensure proper operation of connected users is taken from the public power grid. While if the produced energy is too much, it is directly fed to the grid, thus becoming available to other users.

According to national and local standards and regulations the produced energy can be sold to the grid or credited to the user against future consumption, thus granting a great saving of money.

2.1. Key elements of a photovoltaic system: “STRINGS” and “ARRAYS”

The so-called STRINGS technology has been developed in order to reduce the installation costs of a photovoltaic system as much as possible. These costs are mainly related to the wiring operations on inverter DC side and the consequent distribution on the AC side.

A photovoltaic panel is composed of many photovoltaic cells assembled on the same mount. A STRING is composed of a certain number of panels electrically connected in series. An ARRAY is composed by one or more strings connected in parallel.

Larger photovoltaic systems may be implemented by using several arrays connected to one or more AURORA inverters.

The greater the number of panels in each string, the lower the cost and the less complex the wiring connections of the system.

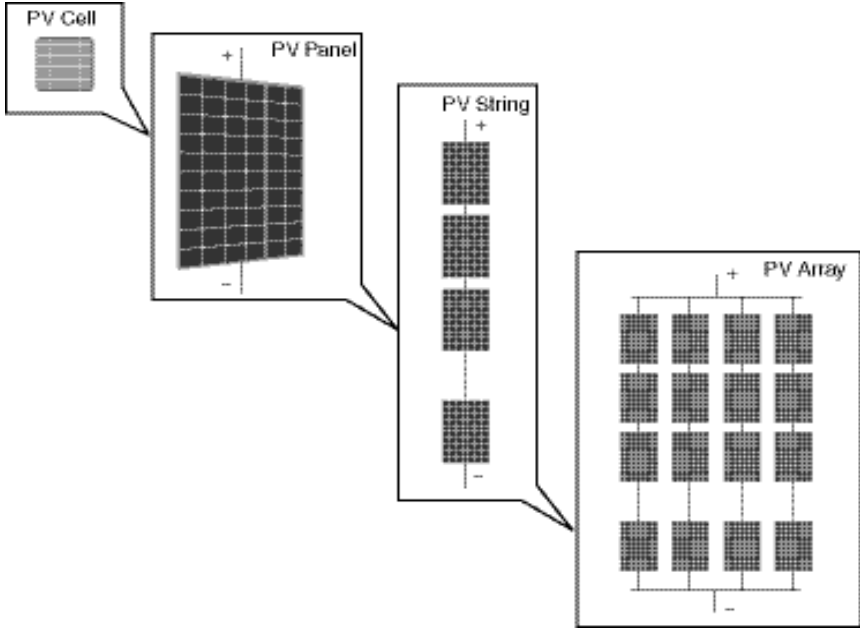

Fig.2 Array Composition



WARNING: String voltage shall not exceed 600 Vdc for any reason, so as to avoid damage to the equipment.



NOTE: A minimum input voltage of 200 Vdc is required for Aurora to start the grid connection sequence. Once connected, Aurora will transfer the maximum power available for any input DC voltage value in a 90V to 580Vdc range to the grid.

The total current of an array must also be within the capability limits of the inverter. For AURORA, the limit is set at 18 Adc maximum for each input. The AURORA model rated 6000W is capable of handling 2 separate arrays. The maximum current limit for each input is 18Adc.

If the output of photovoltaic system exceeds the capacity of a single inverter, additional AURORA inverters can be added to the system; each inverter will be connected to an adequate section of the photovoltaic filed on the DC side and to the grid on the AC side.

Each Aurora inverter will work independent of the others and will push to the grid the maximum power available from its own section of the photovoltaic panels.

There are several factors and considerations to be taken into account when designing a photovoltaic system, such as the type of panels, available room, location, long-term target output, etc. The system configurator available on Power-One's web site at www.power-one.com may help in sizing a photovoltaic system.

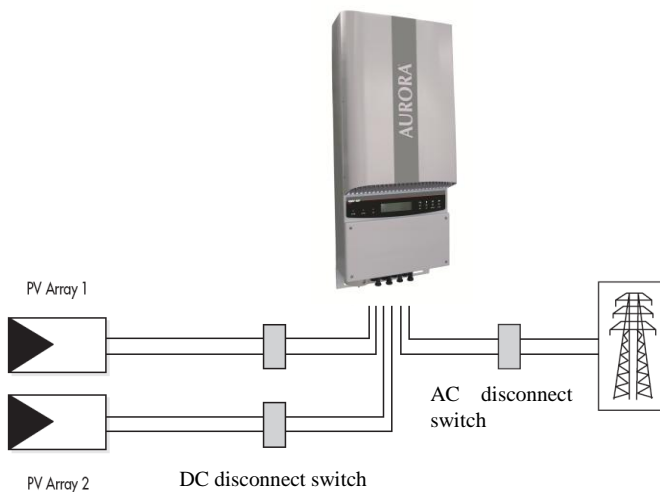

Fig.3 Simplified diagram of a photovoltaic system

2.2. Available versions

PVI-6000-OUTD-AU
PVI-6000-OUTD-S-AU
PVI-6000-OUTD-DS-AU

The identifier –S stands for integrated switch models (with a integrated DC switch 600V rated), as shown in fig. 3B

The identifier –DS stands for integrated diodes and switch models (with a integrated DC switch 600V rated and protection diodes) , as shown in fig. 3C

In fig. 3A is shown the schematic of the model without integrated switch or diodes.

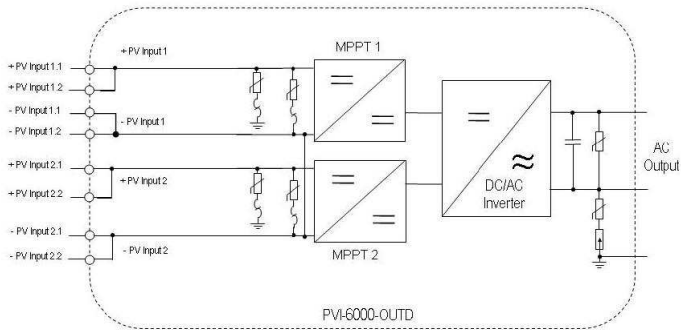

Fig. 3A – No integrated switch or diodes models

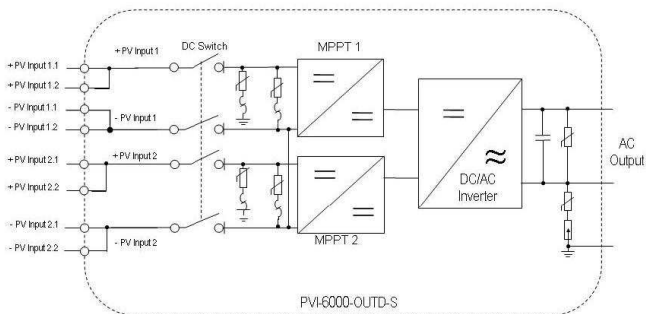

Fig. 3B - Integrated switch models

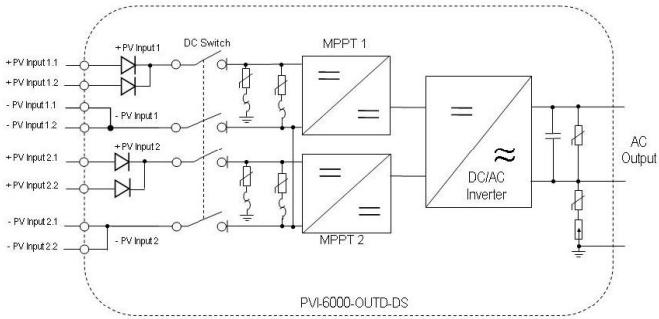

Fig. 3C - Integrated switch and diodes models

2.3. Data Transmission and Check

When more than one inverter is used, remote monitoring can be implemented through a sophisticated communication system based on an RS-485 serial interface, with a USB port to facilitate access during installation. An optional Aurora Easy-Control system is also available for remote monitoring via the Internet, analogue modem or GSM digital modem.

2.4. AURORA Technical Description

Figure 4 shows a block diagram of AURORA. The main elements are the input DC-DC converters (termed “boosters”) and the output inverter. Both the DC-DC converters and the output inverter operate at high switching frequency to enable a compact design and relatively low weight.

This is a transformer-less version of AURORA, i.e. without galvanic insulation between input and output, which further increases conversion efficiency. On the other hand, AURORA is equipped with the necessary protective devices to ensure safe operation in compliance with applicable regulations without an insulation transformer, as discussed in more detail in the relevant section.

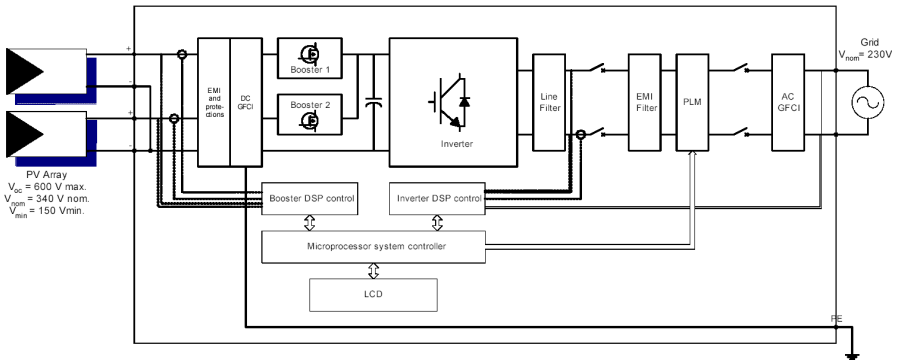

Fig.4 Aurora block diagram

The block diagram shows an AURORA PVI-6000-OUTD with two independent input DC-DC converters; each converter is dedicated to a separate array with independent Maximum Power Point Tracking (MPPT) control. This means that the two arrays can be installed in different positions and orientations. Each array is controlled by an MPPT control circuit.

Thanks to its high efficiency and generously sized heat sink, the AURORA inverter provides maximum power operation in a broad range of ambient temperatures.

The inverter is controlled by two independent DSPs (Digital Signal Processors) and one central microprocessor.

This way, grid connection is controlled by two independent computers in full compliance with electrical power supply and safety regulations.

Aurora operative system communicates with the related parts to proceed to data processing.

This process ensures optimal performance levels of the whole units, as well as a high efficiency under all solar radiation and load conditions, always in full compliance with the applicable directives, standards and regulations.

2.5. Protective Devices

2.5.1 Anti-Islanding

When the local power distribution grid fails due to a fault or when the equipment is shut down for maintenance operations, Aurora shall be physically disconnected under safety conditions, so as to protect the people working on the grid, in full compliance with the applicable prevailing national standards and regulations. To avoid any possible islanding operation, Aurora is provided with an automatic disconnection protective system called Anti-Islanding.

The AURORA PVI-6000-OUTD model is equipped with a state-of-the-art anti-islanding protection system certified to the following standards and regulations:

- AS4777.3-2005

2.5.2 Panel Ground Fault

This version of AURORA has been designed for use with panels with a floating connection (positive and negative terminals not connected to ground). A sophisticated ground protection circuit continually monitors the ground connection; when it detects a ground fault, this circuit shuts down AURORA and turns on a red LED on the front panel to indicate a ground fault condition. The AURORA inverter is equipped with a terminal for the system grounding conductor; see section 3.6 (step 3) for more details.



NOTE: For more details of AURORA shutdown or possible causes of malfunction, please refer to sections 5.3 and 5.4.

2.5.3 Further Protective Devices

Aurora is equipped with additional protections to guarantee safe operation under any circumstances. The protections include:

- constant monitoring of grid voltage to ensure that voltage and frequency remain within the specified operational limits (in accordance with standards);
- automatic power limitation control based on internal temperature monitoring to avoid overheating (heat sink temperature $\leq 70^{\circ}\text{C}$ [158°F]).

Many control devices are fitted to Aurora, making its structure redundant, but at the same time ensuring a perfect and fully safe operation.

3. INSTALLATION



WARNING: The electrical installation of AURORA must be performed in compliance with applicable local and national standards and laws.



WARNING: The connection of Aurora to the electrical distribution grid must be performed only after receiving authorization from the utility that operates the grid.

3.1. Package Inspection



NOTE: The distributor delivered your AURORA to the carrier safely packaged and in perfect condition. Upon acceptance of the package, the carrier assumes responsibility for its safe delivery. In spite of careful handling, transport damage to package or its contents is always a possibility.

The customer is encouraged to perform the following checks:

- Inspect the shipping box for apparent damage, such as holes, cracking or any sign of possible damage to its contents.
- Describe any damage or shortage on the receiving documents and have the carrier sign his/her full name.
- Open the shipping box and inspect the contents for internal damage. While unpacking, be careful not to discard any equipment, parts or manuals. If any damage is detected, call the delivering carrier to determine the appropriate action. Save all shipping material for the event the carrier sends an inspector to verify damage!
- If the inspection reveals damage to the inverter call your supplier, or authorized distributor. They will determine if the equipment should be returned for repair. They will also provide instructions on how to get the equipment repaired;
- It is the customer's responsibility to file a claim with the carrier. Failure to file a claim with the carrier may void all warranty service rights for any damage;
- Save the original package your AURORA inverter came in, should you need to return it for repair in the future.

3.2. Inspecting package contents

| Description | Quantity (No.) |
|---|----------------|
| AURORA inverter | 1 |
| Bag containing: 3 6.3x70 screws, 3 SX10 wall plugs and 1 flat-blade screwdriver w/bent head, 1 M20 cable gland, 1 M32 cable gland, red cable AWG10, black cable AWG10, 1 seal of the 36A3M20 type, cylinder TGM58, Torx20 wrench, 1 6x10 screw, 1 d.18 washer, 4 positive Multi-Contact plugs and 4 negative Multi-Contact plugs ready assembled on the inverter | 1 |
| One copy of this manual | 1 |
| One certificate of warranty | 1 |
| CD-ROM with communication software | 1 |

3.3. Selecting the place of installation

Place of installation should be selected based on the following considerations:

- Height from ground level should be such to ensure that display and status LEDs are easy to read.
- Select a well ventilated place sheltered from direct sun radiation. Choose a place that allows unobstructed air flow around the unit.
- Allow sufficient room around the unit to enable easy installation and removal from the mounting surface.
- A door is provided on unit front to allow for hardware maintenance; the USB port for software connection is on right side wall of the inverter (protected by a cover). Ensure free access to the right side, otherwise you will have to remove the unit from its mounting surface.

The following figure shows the recommended minimum clearances around the inverter:

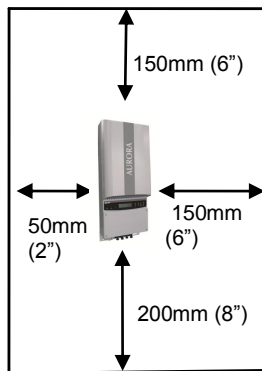

Fig.5 Place of installation - Minimum clearances around AURORA

3.4. Wall mounting

AURORA should be mounted in a vertical position as shown in fig.6. The package includes a hardware kit with 3 6.3x70 steel screws and 3 SX10 wall plugs for installation of metal bracket to a masonry wall. Screws and wall plugs can be installed using 3 of the 5 holes available on the bracket (ref. part C).



WARNING: Bracket shall be mounted vertically on wall: spring side shall face up, while side with M6 PEM shall face down.

Mounting holes for wall mounting should be 8 mm in diameter and min. 70 mm deep.

For wall of other construction materials, it is the installer's responsibility to provide suitable mounting hardware. We recommend using stainless steel screws.

Hang AURORA on the spring at the bracket top, by means of the metal mount fastened to the upper part at inverter back. The central part of this plate features a seat for fastening the spring (Part A).

Once inverter top end is secured in place, you need to secure its bottom end.

From inverter front, use an M6x10 screw and washer to secure the unit to bracket PEM, starting the screw in its thread through lower plate centre slot.

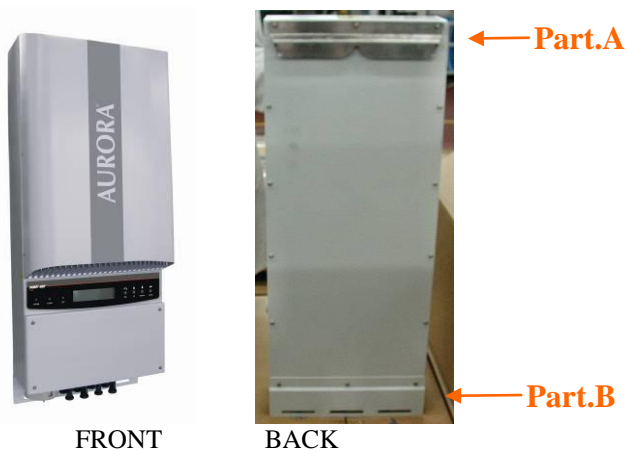
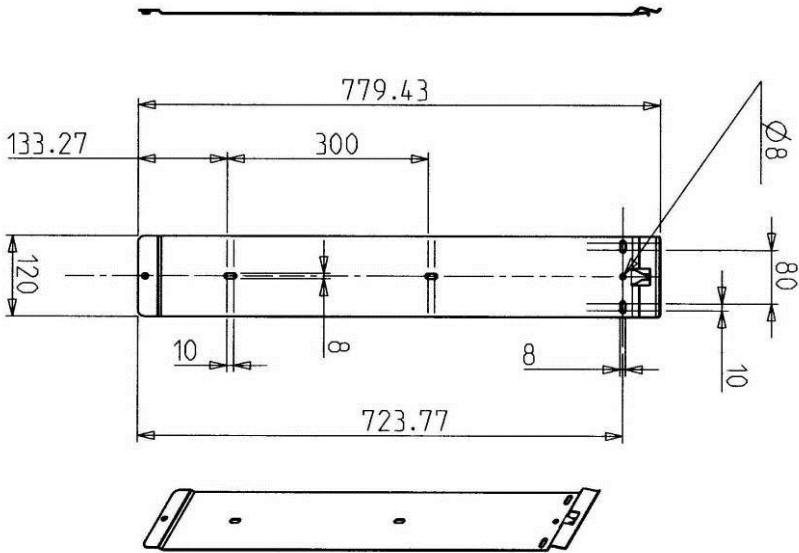



Fig.6 AURORA wall mounting



NOTE: Ensure Aurora is not exposed to direct sun radiation or other external heat sources, including the units installed underneath it (see fig.7). In the event several inverters are stacked up, the heat generated by the inverters placed at the bottom of the stack could cause ambient temperature to rise and affect the operation of the inverters in the upper rows. Temperatures exceeding 40°C could result in a derating of the output power of the units placed in the upper rows.

A combination of high output power and high ambient temperature will make the derating problem even worse. For proper cooling, make sure to install AURORA so as to allow unobstructed air flow (for instance, never with the front panel facing a solid surface).



Fig.7 Recommended installation of AURORA inverters



NOTE: Tilted mounting is allowed (see fig.8), but will worsen heat dissipation and may result in derating.



WARNING: Unit surface may become hot to the touch during operation. DO NOT touch unit surface to avoid burns.

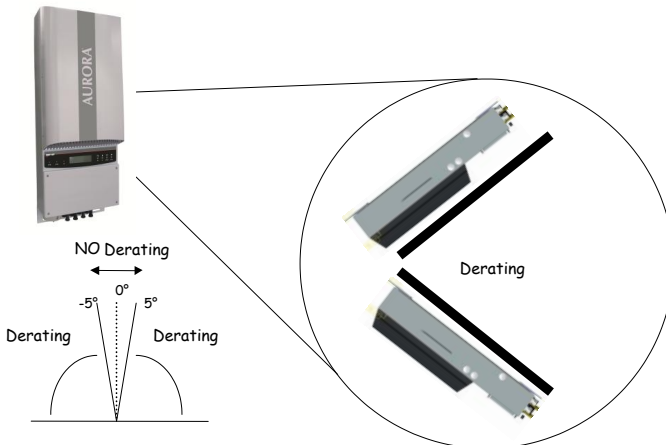

Fig.8 Tilted mounting

3.5. Before performing the electrical connections



WARNING: The electrical connections can be done only after Aurora is firmly mounted to the wall.



WARNING: The connection of Aurora to the electrical distribution grid must be performed by qualified operators and anyway only after receiving authorization from the utility that operates the grid.



WARNING: For a step-by-step description of the correct procedure, please read - and closely follow - the instructions provided in this section (and its subsections) and all safety warnings. Any operation not complying with the instructions below can lead to operator/installer hazards and to equipment damage.



WARNING: Always respect the nominal ratings of voltage and current defined in Section 8 (Technical Characteristics) when designing your system. Please observe these considerations in designing the photovoltaic system:

- Maximum array DC voltage input to each MPPT circuit: 600Vdc under any condition.
- Maximum array DC current input to each MPPT circuit: 18Adc under any condition.



WARNING: Check the National and local standard regulations to make sure your electrical installation design is in compliance with them.



WARNING: Cover the whole surface of the photovoltaic panels using a (preferably black) material opaque to solar radiation during the installation procedure. Remove the protective material when installation is complete.



NOTE: In accordance with the typical assembly diagram (see Fig.9), each array must be connected to a two-pole DC disconnect switch. An AC disconnect switch with overload cutout must be used to connect AURORA to the grid. Recommended ratings for the disconnect switch or the overload cutout are maximum 40A, 240V.

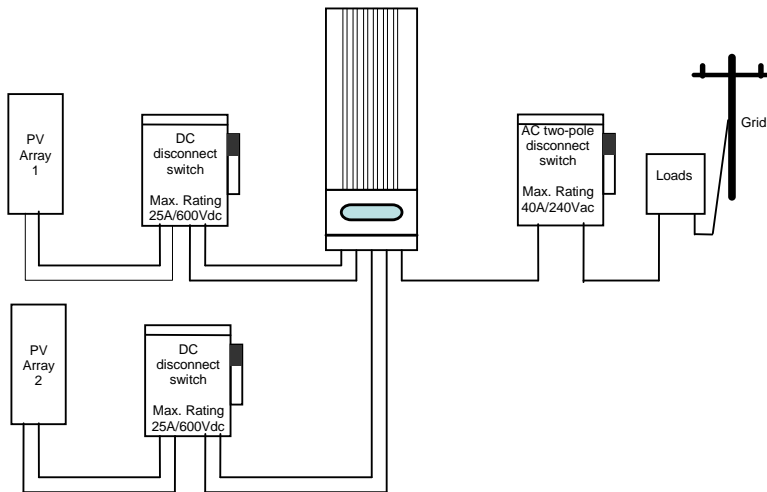

Fig.9 Wiring diagram



WARNING: When disconnecting AURORA from the grid, always open the AC disconnect before the DC disconnect.



WARNING: When selecting the power supply cables for AURORA connection, please carefully consider nominal operating voltage, insulation voltage, maximum operating temperature, current density and flammability rating. All of these values must comply with the maximum current density ratings required by applicable local rules.

A key consideration in cable selection is cable loss, as exceeding loss will lead to derating.

The maximum cross-section area allowed for the conductors to be assembled to the terminal blocks for grid connection is 16 sq mm. The supplied M32 cable gland accepts wires up to 19 sq mm.

Inverter bottom features (see Fig. 10, from right to left):

- 2 holes blanked with waterproof caps. Remove the caps to gain access to the connectors for data serial transfer via RS485 port. One hole is for the input serial cable and the other for an output cable, if fitted (output cable is required when several inverters are connected in a daisy-chain configuration, see Section 6).
- Cable gland for AC grid connection
- 4 pairs of Multi-Contact (MC4) connectors for the two photovoltaic arrays.

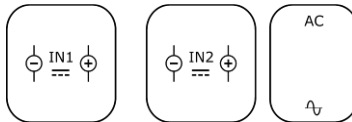

Fig. 10 Connectors found on inverter bottom and their labels



WARNING: When making the electrical connections follow this exact procedure to avoid exposure to dangerous voltages. Each step of the procedure is explained in the following paragraphs. To disconnect AURORA, perform steps 1/5 and 2/5 and then disconnect the AC and DC connectors.

3.6. Electrical Connections

Step 1/5: Open the AC grid disconnect switch

Step 2/5: Open the photovoltaic field DC disconnect switch

Step 3/5: Unscrew the 4 captive screws to open the front panel

Step 4/5: Connect AURORA to the AC grid disconnect switch



WARNING: Use suitable low-impedance cables to connect AURORA to the AC disconnect switch.



WARNING: AURORA must be connected to the AC grid disconnect switch using a three-wire cable with a line wire, a neutral wire and a yellow-green ground (PE or protective earth) wire.

- 1) Route the cable from AURORA to the Ac disconnect
- 2) Connect the three-pole cable to Aurora using the cable gland on the case
- 3) Connect the three wires as follows:
 - terminal 1 for Protective  earth PE
 - terminal 2 for Neutral N,
 - terminal 3 for Line L,



Fig.11 AC wire terminal block



WARNING: Do not reverse phase and neutral as this might make the system unsafe to run and cause malfunctioning.



NOTE: If you have installed a meter between the AC disconnect and AURORA, follow the same procedure outlined above when connecting the meter.

Step 5/5: Connect AURORA to the photovoltaic field DC disconnect switches

Power-One strongly recommends using two separate arrays whenever possible. Each array should have a current capacity lower than 18Adc and should be connected to one input section of the AURORA inverter.



WARNING: Ensure that photovoltaic field voltage polarity matches the “+” and “-” symbols.

Before connecting Aurora with the photovoltaic field, Power-One recommends to check, using a proper gauge, that the polarity value and the voltage allowed value between positive and negative contacts are correct.

To connect the arrays, follow this procedure for each array:

- 1) Route the positive cable from the Dc disconnect to AURORA.
- 2) Connect the cable to the mating connector of the Multi-Contact connector (mating connector not included in scope of supply)
- 3) Connect the positive cable to AURORA
- 4) Route the negative cable from the Dc disconnect to AURORA.
- 5) Connect the cable to the mating connector of the Multi-Contact connector (mating connector not included in scope of supply)
- 6) Connect the negative cable to AURORA



WARNING: Some systems may feature a single array. When this is the case, the array may be connected to the IN1 section alone provided that array current is less than the maximum capacity of one AURORA section (less than 18Adc). To avoid possible problems when determining panel electric insulation parameters, short the inputs of the second section (IN2) by connecting a cable to the suitable terminals on the inverter board as shown in Fig. 12. Remove the panel on Aurora front end to gain access to the board.

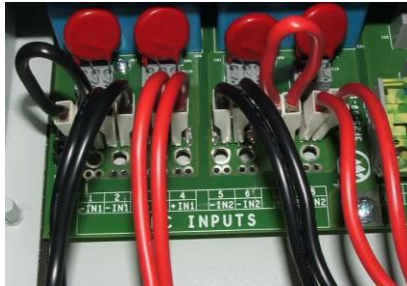

Fig.12A: Connections present on unit as supplied

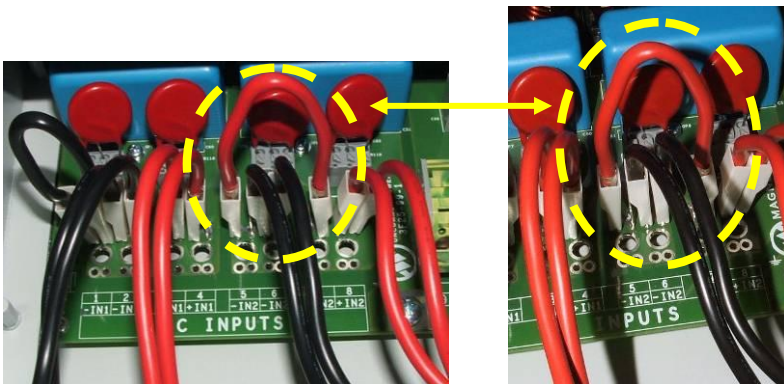

Fig.12B: Connections required to short channel 2



WARNING: If array current exceeds the maximum capacity of one inverter input section (18A_{dc}), connect the two sections in parallel by jumpering the terminals behind the cover (see section 3.7). Jumper wires should have a 6 sq mm cross-section area (AWG10); connect the negative wire across terminals -IN1 and -IN2 and the positive wire across terminals +IN1 and +IN2 as shown in Fig.13. You will also have to set the inverter for parallel connection (single string) operation by setting the switch shown in fig. 13 to “PAR”



Parallel connection of the two

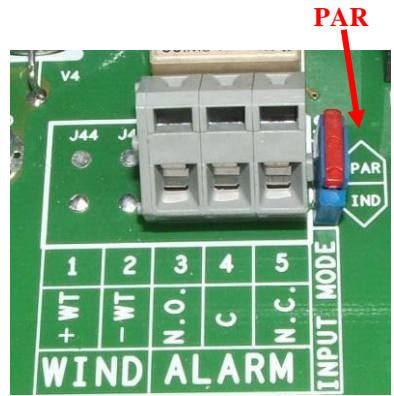

Inverter “parallel” mode configuration

Fig. 13 Connection/configuration for parallel-connected sections

3.7. How to access the internal terminal boards through the front panel



WARNING: Shock hazard! Before removing the front panel, disconnect AURORA at both the AC and DC side and allow 5 minutes for the internal capacitors to discharge.

To remove the front panel, unscrew the 4 screws shown in figure 14 using the supplied flat-blade screwdriver.



Fig.14 AURORA with front panel

After refitting the front panel, tighten the screws to 1.5 Nm (13.2 in-lbs) as a minimum to ensure proper sealing.

3.8. Replacing the CR2032 lithium battery

Aurora incorporates a CR2032 lithium battery. When the battery is nearing the end of its life, a corresponding message appears on the LCD display.

Remove the front panel (see fig.15) to expose the battery.

Please note that the battery will not fit into its mount from the top down; slide the battery into its mount from side A, while holding it tilted at a 30° angle. The battery will slide into place into the battery mount.

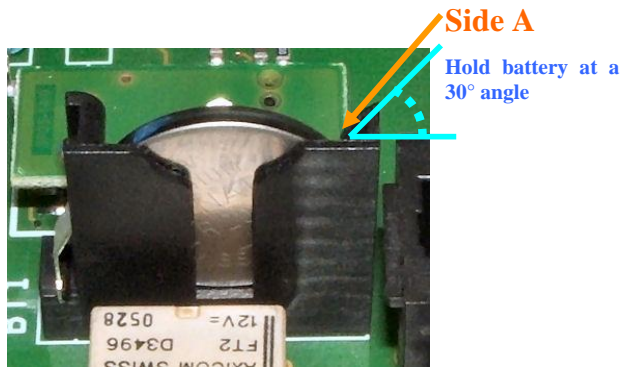

Fig.15 Battery in place



WARNING: This component should only be replaced by qualified personnel.

3.9. Replacing the memory

All energy output logs are stored in this memory. If you need to replace the inverter, the memory can be removed from the old unit and fitted into the new inverter. This way, you will retain all system logs and keep saving future daily logs to the memory (see fig.16)

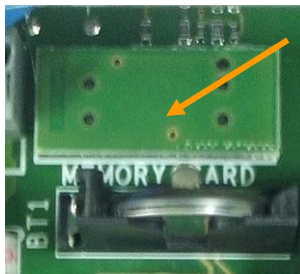

Fig.16 Inverter memory



WARNING: This component should only be replaced by qualified personnel.



WARNING: Make sure to insert the memory connector pins correctly into the board connector.

4. START-UP



WARNING: Do not place any items on AURORA during operation.



WARNING: Do not touch the heat sink when the inverter is operating, as some parts may be hot and cause burns.

The start-up procedure is as follows:

1) Set the external DC disconnect (for the photovoltaic panels) to ON

2) Set the external AC disconnect (for the grid) to ON.

There is no specific order for closing the two disconnects.

3) Once both disconnects are closed, the inverter starts the grid connection sequence, unless the grid voltage and frequency parameters are found to be outside the operating range as per national standards. The check routine is indicated by the green LED labelled POWER over the display flashing.

The check routine may take 30 seconds up to several minutes, depending on grid condition. Three screens are shown on the display during the check routing:

- “Measuring Riso...”, connection in progress with progress indication.
- Grid voltage value and status compared to specified values (within/outside range).
- Grid frequency value and status compared to specified values (within/outside range).

4) When the connection sequence is completed, AURORA starts operating; proper operation is indicated by a warning sound and the green LED staying on. This means that sun radiation is sufficient to feed the grid.

5) If the grid check routine gave a negative result, the unit will repeat the procedure until all grid voltage and frequency parameters and grid configuration are found to be in the specified range. During this process, the green LED will keep flashing.

5. MONITORING AND DATA TRANSMISSION

5.1. User's Interface Mode



WARNING: The RS-485 cable must provide at least 600V protection.

Normally, the AURORA inverter operates automatically and needs no particular supervision. When solar radiation is not enough to generate power for the grid (for instance, at night), AURORA disconnects automatically and goes into stand-by mode.

The operating cycle is resumed automatically the moment solar radiation becomes strong enough. This is indicated by the LEDs.

Aurora inverter can provide operational data in the following ways:

- LED indicators
- Operational data on the LCD display
- Data transmission on a dedicated serial RS-485 line. Data can be collected by a PC or a data logger equipped with an RS-485 port. If an RS-485 line is used, it may be convenient to use the AURORA RS-485/RS232 Serial Interface Converter model number PVI-RS232485. An optional AURORA Easy Control data logger is also available.
- Data transmission via USB cable. This type of connection is typically used when monitoring a single inverter and for maintenance purposes. To connect the USB cable, remove the waterproof plug at the bottom end of the inverter right wall (Fig.17).

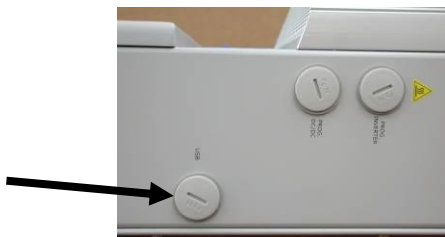

Fig.17 USB port

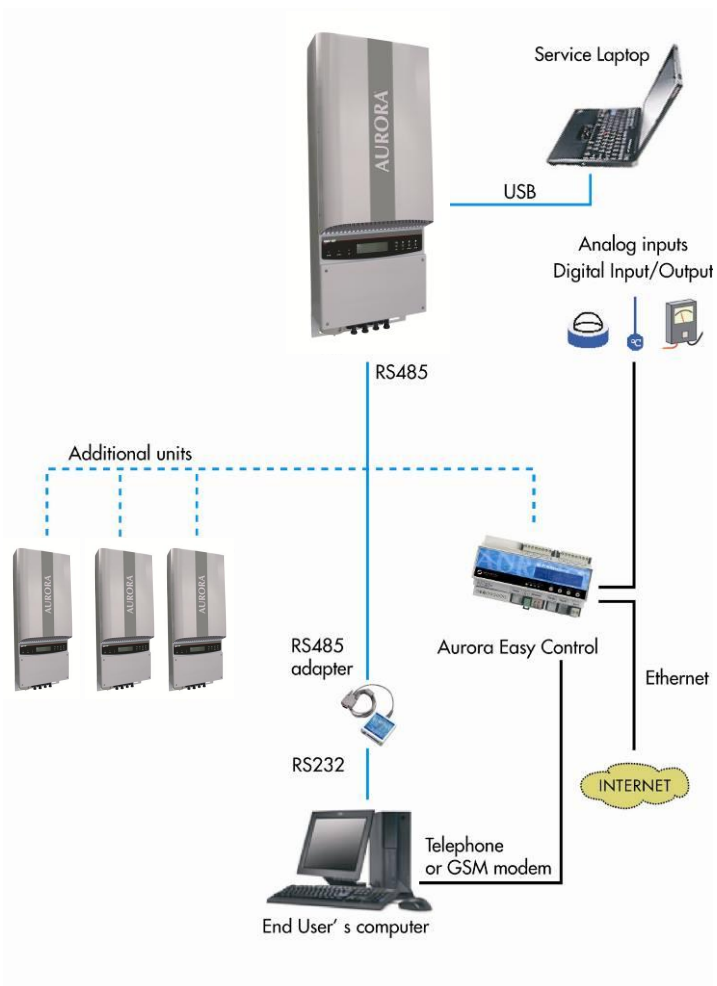

Fig. 18 Data Transmission Options

5.2. Available Data

AURORA provides two types of data that can be collected using the suitable interface software.

5.2.1 Real-time operational data

Real-time operational data can be transmitted on demand through the communication lines and are not stored by the inverter. The free AURORA Communicator software available on the installation CD may be used to transmit data to a PC (please check for the latest updated version at www.power-one.com).

The following data is available:

- Grid voltage
- Grid current
- Grid frequency
- Power transferred to the grid
- Voltage of photovoltaic array 1
- Current of photovoltaic array 1
- Voltage of photovoltaic array 2
- Current of photovoltaic array 2
- Heat sink temperature)
- Serial Number Part Number
- Manufacturing week
- Firmware revision code
- Daily energy
- Leakage current of the system
- Total energy
- Partial energy
- Mean grid voltage
- Insulation resistance
- Leakage current to ground
- Date, time

5.2.2 Internally logged data

Aurora stores internally the following data:

- Lifetime counter of grid connection time
- Lifetime counter of energy transferred to the grid
- Energy transferred to the grid every 10 seconds for the last 8640 periods of 10 seconds (which on average cover more than 2 days logged data)
- Partial counter of grid connection time (counter start time can be reset using the AURORA Communicator software)
- Partial counter of energy (uses the same start time of the partial time counter)
- Last 100 fault conditions with error code and time stamp
- Last 100 changes to grid connection parameters with parameter code and new value.

The first two types of data are displayed on the LCD and through the RS-485 interface, while all other data can be displayed only through RS-485 interface

5.3. LED indicators

There are three LEDs at the side of the display: the first LED from the left (POWER) indicates proper operation of the inverter, the LED in the middle (FAULT) indicates a fault condition, whereas the LED on the right (GFI) indicates a ground fault.

1. The green “Power” LED indicates that AURORA is operating correctly.
This LED flashes upon start-up, during the grid check routine. If a correct grid voltage is detected and solar radiation is strong enough to start up the unit, the LED stays on steady. If not so, the LED keeps flashing until solar radiation becomes strong enough to start up the inverter. In this condition, the display will read “Waiting for sun....”
2. The yellow “FAULT” LED indicates that AURORA has detected a fault condition. A fault description appears on the display.
3. The red “GFI” (ground fault) LED indicates that AURORA is detecting a ground fault in the photovoltaic system (DC side). When this kind of fault is detected, AURORA immediately disconnects from the grid and the corresponding fault indication appears on the display. AURORA remains in this condition until the operator presses the ESC key to re-start the grid connection sequence. If AURORA does not reconnect to the grid, call service to have the system troubleshooted.

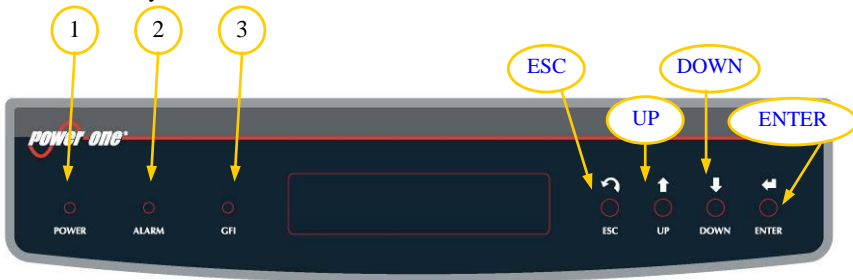

Fig.19 LED location

Possible LED combinations and their meanings are listed in the following table.

KEY:



LED on























LED blinking



LED off















Any one of the above conditions

| | LEDs Status | Operational Status | Remarks |
|---|---|--|---|
| 1 | green:  yellow:  red:  | Aurora self-disconnection during nighttime | Input voltage less than 90 Vdc at both inputs |
| 2 | green:  yellow:  red:  | Aurora initialization, settings loading and waiting for grid check | It is a transition status while operating conditions are checked. |
| 3 | green:  yellow:  red:  | Aurora is powering the grid | Standard machine operation (search of max. power point or constant voltage). |
| 4 | green:  yellow:  red:  | System insulation device faulty | Ground leakage found |
| 5 | green:  yellow:  red:  | Defect – fault!!! | The Fault can be inside or outside the machine. See the alarm appearing on the LCD. |
| 6 | green:  yellow:  red:  | Installation phase: Aurora is disconnected from grid. | During installation, it refers to set-up of the address for RS-485 communication. |
| 7 | green:  yellow:  red:  | Grid disconnection | Indicates a missing grid condition |



NOTE: Inverter status is indicated by the corresponding LED turning steady on or flashing and by a display message that provides a description of current operation or fault condition (see next sections).

- G**  1) **Nighttime mode**
Y  AURORA disconnected during night time; this occurs when input
R  power is too low to feed the inverter.
- G**  2) **AURORA initialization and grid check**
Y  Initialization in progress: input power sufficient to feed the
R  inverter; AURORA is verifying start-up conditions (for instance:
input voltage value, insulation resistance value, etc.) and grid
check routine is launched.
- G**  3) **AURORA is feeding the grid**
Y  After completing a set of electronics and safety auto-test routines,
R  the inverter starts the grid connection process.
As mentioned above, during this stage AURORA automatically
tracks and analyzes the maximum power point (MPPT) of the
photovoltaic field.
- G**  4) **Ground insulation fault**
Y  AURORA indicates that insulation resistance was found to be too
R  low.
This may be due to an insulation fault in the connection between
the photovoltaic field inputs and the ground.











WARNING: Shock hazard! Do not attempt to correct this fault yourself. The instructions below have to be followed very carefully. In case you are not experienced or skilled enough to work safely on the machine, contact a specialized technician.

What to do after an insulation defect has been found

When the red LED turns on, try to reset the fault indication by pressing the multi-function ESC key at the side of the display. If AURORA reconnects to the grid, the fault was due to a transient event (such as condensation and moisture getting into the panels). If this trouble occurs frequently, have the system inspected by a specialized technician.

If AURORA does not reconnect to the grid, open both the DC and AC disconnect switches to place AURORA into a safe condition and contact an authorized service center to have the system repaired.

- G**  **5) Malfunction/Fault indication**
Y  Every time Aurora check system detects an operative malfunction
R  or fault of the monitored system, the yellow LED comes on and a
message showing the type of problem found appears on the LCD.
- G**  **6) RS-485 address setup indication**
Y  During installation, the yellow LED will keep flashing until the
R  address is acknowledged. For further information about address
entering, refer to section 6.3.
- 7) Grid disconnection**
G  If a grid failure event occurs while the system is regularly
Y  operating, the yellow LED turns on steady.
R 

5.4. Messages and Error Codes

The system status is identified through message or error signals appearing on the LCD.

The tables below summarize the two types of signals that can be displayed.

MESSAGES identify current AURORA status; so they do not relate to faults and nothing has to be done; messages disappears as soon as the system is back to normal operating conditions. See W strings in the table below.

ALARMS identify a possible fault of the equipment or of the connected parts. Alarm signals will disappear as soon as the causes are removed, except for ground insulation faults in the photovoltaic panels, which have to be corrected by qualified personnel. Usually, when an error signal appears, an action is needed. This action will be managed as much as possible by Aurora or, in case this is not possible, Aurora will supply all the necessary helping information to the person who will have to carry out the maintenance operations to fix the fault on the equipment or system. See E strings in the table below.

| Message | Warning | Error type | Description |
|-----------|---------|------------|--|
| Sun Low | W001 | // | Input Voltage under threshold <i>Input voltage under threshold (when off)</i> |
| Input OC | // | E001 | Input Overcurrent |
| Input UV | W002 | // | Input Undervoltage |
| Input OV | // | E002 | Input Overvoltage |
| Int.Error | // | E003 | No parameters <i>No parameters</i> |
| Bulk OV | // | E004 | Bulk Overvoltage |
| Int.Error | // | E005 | Communication Error <i>Communication error</i> |
| Out OC | // | E006 | Output Overcurrent |
| Int.Error | // | E007 | IGBT Sat |
| Sun Low | W011 | // | Bulk Undervoltage |
| Int.Error | // | E009 | Internal Error <i>Internal Error</i> |

| Message | Warning | Error type | Description |
|------------|---------|------------|---|
| Grid Fail | W003 | // | Grid Fail <i>Wrong grid parameters</i> |
| Int.Error | // | E010 | Bulk Low |
| Int.Error | // | E011 | Ramp Fail |
| DC/DC Fail | // | E012 | DcDc Error revealed by inverter <i>DcDc fault detected by inverter</i> |
| Wrong Mode | // | E013 | Wrong Input setting (Single instead of dual) <i>Wrong input setting (single instead of dual channel)</i> |
| Over Temp. | // | E014 | Overtemperature <i>Internal temperature too high</i> |
| Cap. Fault | // | E015 | Bulk Capacitor Fail <i>Bulk capacitor fault</i> |
| Inv. Fail | // | E016 | Inverter fail revealed by DcDc <i>Inverter fault detected by DcDc</i> |
| Int.Error | // | E017 | Start Timeout |
| Ground F. | // | E018 | I leak fai <i>Leakage current fault I</i> |
| Int.Error | // | E019 | Ileak Sensor fail <i>Leakage current fault</i> |
| Int.Error | // | E020 | DcDc relay fail <i>DcDc relay fault</i> |
| Int.Error | // | E021 | Inverter relay fail <i>Inverter relay fault</i> |
| Int.Error | // | E022 | Autotest Timeout |
| Int.Error | // | E023 | Dc-Injection Error |
| Grid OV | W004 | // | Output Overvoltage |
| Grid UV | W005 | // | Output Undervoltage |
| Grid OF | W006 | // | Output Overfrequency |
| Grid UF | W007 | // | Output Underfrequency |
| Z Grid HI | W008 | // | Z grid out of range <i>Impedance outside range</i> |
| Int.Error | // | E024 | Unknown Error – <i>Internal Error</i> |
| ----- | // | E025 | Riso Low (Log Only) <i>Low insulation resistance (Log only)</i> |
| Int.Error | // | E026 | Vref Error <i>Wrong reference voltage (VRef)</i> |
| Int.Error | // | E027 | Vgrid Measures Fault <i>Grid voltage (VGrid) misreading</i> |
| Int.Error | // | E028 | Fgrid Measures Fault <i>Grid frequency (FGrid) misreading</i> |
| Int.Error | // | E029 | Zgrid Measures Fault <i>Grid impedance (ZGrid) misreading</i> |

| Message | Warning | Error type | Description |
|-----------|---------|------------|--|
| Int.Error | // | E030 | Ileak Measures Fault <i>Leak current (ILeak) misreading</i> |
| Int.Error | // | E031 | Wrong V Measure <i>Voltage (V) misreading</i> |
| Int.Error | // | E032 | Wrong I Measure <i>Current (I) misreading</i> |
| Fan Fail | W010 | // | Fan Fail (No disconnection) <i>Fan faulty (Log Only)</i> |
| Int.Error | // | E033 | UnderTemperature <i>Internal temperature</i> |
| | // | E034 | Interlock Fail (Not Used) |
| | // | E035 | Remote Off <i>Remote power-off</i> |
| | // | E036 | Vout Avg <i>Average output voltage outside range</i> |
| | W012 | // | Clock Battery Low (No disconnection) <i>Clock battery low (not operating)</i> |
| | W013 | // | Clock Failure (No disconnection) <i>Clock faulty (not operating)</i> |

5.5. LCD Display

5.5.1 Connection of system to the grid

The two-line Liquid Crystal Display is located on the front panel and shows:

- ✓ Inverter operating status and statistics;
- ✓ Service messages for operator;
- ✓ Error messages and fault indications.

During regular operation, the display will cycle through available data. The display changes to a different screen every 5 seconds, or screens may be scrolled manually by pressing the UP (2nd key from display) and DOWN keys (3rd key from display).

1) These two screens are displayed upon inverter start-up:

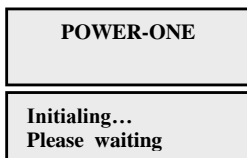

2) The following screens may appear while waiting for the connection to be established:



- While the system checks for grid connection to be established (“Missing Grid”), the yellow LED next to the display turns on steady, while the green LED is flashing.
- When waiting for sun radiation (“Waiting Sun”), the green LED turns on steady.
- When the “Missing Grid” and “Waiting Sun” conditions are verified, the inverter is connected.

3) Time (seconds) to complete output voltage and frequency check.



4) Shows instant output voltage value and within/outside range status.

| | |
|-----------------|----------------|
| Vgrid | 197.8 V |
| In range | |

5) Shows instant output frequency value and within/outside range status.

| | |
|-----------------|-----------------|
| Fgrid | 50.17 Hz |
| In range | |

6) If measured instant values of voltage (step 4) and frequency (step 5) are outside the allowed range, the following screens are shown alternately

- Next connections (screen 3)
- Vgrid (screen 4)
- Fgrid (screen 5)

7) Instant value of insulation resistance

| |
|----------------------------|
| Meas. Riso |
|----------------------------|

5.5.2 Error messages

After the connection is established, the inverter runs a test cycle; if wrong data is found, the cycle is interrupted and an error code is displayed. Please look up error codes and their meaning in the table in section 5.4.

Until the error is rectified, the following screens are shown alternately:

| |
|----------------------------|
| ERROR Code |
|----------------------------|

| |
|----------------------------------|
| Type OUTD Part No..... |
|----------------------------------|

| |
|---------------|
| S/N |
| Firmware..... |

Once the error has been removed, the inverter resets all functions in progress and re-starts the connection (Sect.5.5.2 Connection of system to the grid, item 2)

- Missing Grid
- Waiting Sun

5.5.3 First phase - electric parameter check

A FEW POINTERS ON DISPLAY KEY OPERATION:

During regular operation, the display will cycle through available data. The display changes to a different screen every 5 seconds, or screens may be scrolled manually by pressing the UP (2nd key from display) and DOWN keys (3rd key from display).

Either way, pressing the ESC key (right next to the display) calls back the previous menu.



Fig.20



Fig.21

Auto-scroll is indicated by 2 arrows in the top left corner of the display (Fig.20).

To stop auto-scroll, press the **ENTER** key (4th key from display). A padlock will appear (Fig.21).

1A) If the measurements taken previously (see sect. 5.5.1) are found to be correct, the system will proceed to the next checks. The 12 screens outlined below are shown alternately as mentioned in section “**A FEW POINTERS ON DISPLAY KEY OPERATION**”.

| | |
|------|-------|
| Type | OUTD |
| PN | ----- |

2A) shows inverter serial number and firmware revision level.

| | | |
|-----|-------|---------|
| S/N | ----- | xxxxxx |
| FW | rel. | C.0.1.1 |

3A)

| | | |
|--------|-----|-----|
| E-tod | 0 | Wh |
| \$-tod | 0.0 | EUR |

E-tod : Daily energy output.

\$-tod: Daily energy savings. Value is expressed in the set currency.

4A)

| | |
|--------------|-------|
| E-tot | ----- |
| E-par | 0 KWh |

E-tot : Lifetime energy output (since first installation)

E-par : Partial energy output (during selected period)

5A)

| | |
|--------------|------|
| P-out | 0 W |
| T-inv | - °C |

P-out : Measured instant output power

The second line of the display shows the higher of two temperatures:

T-inv: inverter heat sink temperature

T-boost: Heat sink temperature

6A)

| | |
|----------------|--------|
| Ppk | W |
| Ppk Day |W |

Ppk: Maximum peak power achieved since partial counter was activated

Ppk Day: Maximum peak power achieved during the day. Counter will reset when unit is powered off.

7A)

| | |
|------------------|-------|
| Vgrid | 197 V |
| Vgrid Avg | 0 V |

Vgrid: Measured instant grid voltage

Vgrid Avg: Average grid voltage during the last 10 minutes of operation

8A)

| | |
|--------------|----------|
| Igrid | 0.8 A |
| Fgrid | 50.18 Hz |

Igrid: Measured instant grid current

Fgrid: Measured instant grid frequency

9A)

| | |
|--------------|--------------|
| Vin1 | 0 V |
| I in1 | 0.0 A |

Vin1: Instant input voltage measured at channel 1 input

Iin1: Instant input current measured at channel 1 input

10A)

| | |
|--------------|--------------|
| Vin2 | 0 V |
| I in2 | 0.0 A |

Vin2: Instant input voltage measured at channel 2 input

Iin2: Instant input current measured at channel 2 input

Or:

| | |
|-------------|--------------|
| Vin | 0 V |
| I in | 0.0 A |

In a configuration with one input connected and a second input connected in parallel, the following screen is shown instead of the 2 screens described above.

11A)

| | |
|--------------|------------|
| Pin 1 | 0 W |
| Pin 2 | 0 W |

Pin1: Measured instant input power of channel 1

Pin2: Measured instant input power of channel 2

| | |
|------------|------------|
| Pin | 0 W |
|------------|------------|

In a configuration with one input connected and a second input connected in parallel, the following screen is shown instead of the screen described above.

12A)

| | |
|--------------|-----------------|
| Riso | 0.0 Mohm |
| Ileak | 73 mA |

Riso: Measured insulation resistance. Unlike the parameters discussed above, this is not an instant value but a one-off measurement taken upon inverter start-up.

13A)

| |
|---|
| <p>Inverter OK Wed 17 May 11 23</p> |
|---|

If all items described above tested are OK, the inverter shows a corresponding message in the display top line along with date and time. Clock malfunctioning or other non function-related faults (meaning such faults that do not affect the inverter's ability to generate energy) are shown in the bottom line of the display in place of date and time.

The following error messages are provided:

- CLOCK FAIL indicates clock malfunction, contact service
- BATTERY LOW
- SET TIME, appears the first time the unit is powered up or after the battery has been replaced.
- FAN FAIL: contact service
- MEMORY FAIL: Data logging malfunction. Contact service.

5.5.4 Main menu

When the grid connection sequence described above and all electrical parameter checks are completed, other screens become available. These screens let you monitor inverter operation.

Pressing the ESC key (right next to display) gives access to 3 new screens:



A FEW POINTERS ON DISPLAY KEY OPERATION:

- Press the UP (2nd key from display) and DOWN keys (3rd key from display) to scroll through items.
- Press the ESC key (right next to display) to go back to the previous session (see sect. 5.5.3).
- Press ENTER (4th key from display) to open the selected submenu.

5.5.5 Statistics

Select the STATISTICS menu to display the following submenu:

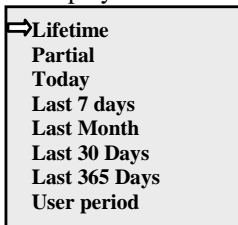

The display has 2 lines; use the keys at the side of the display to scroll through items or open the corresponding submenus as described in section 5.5.3 A FEW POINTERS ON DISPLAY KEY OPERATION.

An arrow on the left side of the display highlights your current selection as shown in the following figure:



5.5.5.1 Lifetime

Select Lifetime to view the following information:

| | |
|-------|-----|
| Time | h |
| E-tot | KWh |
| Val. | EUR |
| CO2 | Kg |

Time: Lifetime operation time

E-tot : Lifetime energy output

Val. : Money earned

CO2: CO2 saving compared to fossil fuels

5.5.5.2 Partial

Select Partial to view the following information:

| | |
|--------------|------------|
| Time | h |
| E-par | KWh |
| Ppeak | W |
| Val. | EUR |
| CO2 | Kg |

Time: Total operation time since counter was last reset *

E-par: Total energy output since counter was last reset *

PPeak: Maximum peak power measured since Partial counter was activated

Val.: Money earned since counter was last reset *

CO2: CO2 saving compared to fossil fuels since counter was last reset *

* Hold the ENTER key (4th key from display) depressed for over 3 seconds to reset all counters in this submenu. After 3 seconds, a warning sound is repeated 3 times.

5.5.5.3 Today

Select Today to view the following information:

| | |
|--------------|------------|
| E-tod | KWh |
| Ppeak | W |
| Val. | EUR |
| CO2 | Kg |

E-tod: Total energy output during the day

Ppeak: Peak power achieved during the day

Val: Money earned during the day

CO2: CO2 saving compared to fossil fuels during the day

5.5.5.4 Last 7 days

Select Last 7 days to view the following information:

| | |
|-------------|------------|
| E-7d | KWh |
| Val. | EUR |
| CO2 | Kg |

E-7d: Total energy output during the last 7 days

Val. : Money earned during the last 7 days

CO2: CO2 saving compared to fossil fuels during the last 7 days

5.5.5.5 Last Month

Select Last Month to view the following information:

| | |
|--------------|------------|
| E-mon | KWh |
| Val. | EUR |
| CO2 | Kg |

E-mon: Total energy output during the month

Val. : Money earned during the month

CO2: CO2 saving compared to fossil fuels during the month.

5.5.5.6 Last 30 Days

Select Last 30 Days to view the following information:

| | |
|--------------|------------|
| E-30d | KWh |
| Val. | EUR |
| CO2 | Kg |

E-30d: Total energy output during the last 30 days

Val. : Money earned during the last 30 days

CO2: CO2 saving compared to fossil fuels during the last 30 days

5.5.5.7 Last 365 Days

Select Last 365 Days to view the following information:

| | |
|---------------|------------|
| E-365d | KWh |
| Val. | EUR |
| CO2 | Kg |

E-365d: Total energy output during the last 365 days

Val. : Money earned during the last 365 days

CO2: CO2 saving compared to fossil fuels during the last 365 days

5.5.5.8 User period

| |
|--------------------|
| User period |
|--------------------|

This feature measures energy saving during a period selected by the user. Press ENTER from the “User period” screen to access the following submenu:

| | |
|--------------|------------------|
| Start | 23 June |
| End | 28 August |

Use the display keys to set the start and end date of the period as follows:

- Use ENTER to move from one field to the next (from left to right)
- Use ESC to go back to the previous field (from right to left)
- Press ESC repeatedly to go back to the previous menus as described in sect. 5.5.3

To set days:

- Press DOWN to scroll numbers backwards (from 31 to 1)
- Press UP to scroll numbers from 1 to 31

To set the month:

- Press DOWN to scroll months from December to January
- Press UP to scroll months from January to December

If set dates are inconsistent, the display alerts the user to the problem:

| |
|-----------------|
| Data err |
|-----------------|

5.5.6 Setting

Select SETTING from the Main menu (sect. 5.5.4) to display the first screen, that refers to the password:



Default password is 0000. It can be changed using the keys on display as usual:

- Use ENTER to move from one figure to the next (from left to right)
- Use ESC to go back to the previous figure (from right to left)
- Press ESC repeatedly to go back to the previous menus as described in sect. 5.5.3
- Press DOWN to scroll numbers backwards (from 9 to 0)
- Press UP to scroll numbers from 0 to 9

Type in the correct password and press ENTER to access all information of this section:

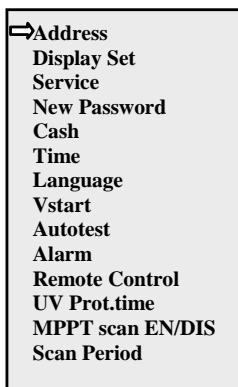

The display has 2 lines; use the keys at the side of the display to scroll through items or open the corresponding submenus as described in section 5.5.4 **A FEW POINTERS ON DISPLAY DATA READING.**

An arrow on the left side of the display highlights your current selection. When the chosen item is selected, press ENTER to open the submenu.

5.5.6.1 Address

This function is used to set addresses for communication of the single inverters connected in the system on RS485 line. You can assign numbers from 2 to 250. Press UP and DOWN to scroll numbers.

If you do not want to manually set the address of each inverter, select the AUTO function and they will be distributed automatically.

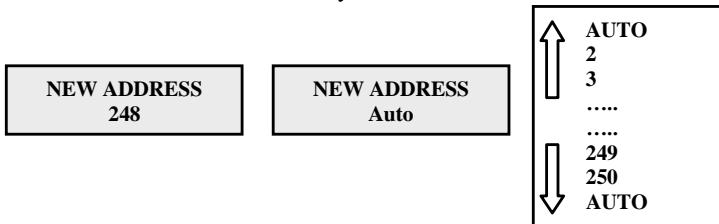

5.5.6.2 Display Set

This function is used to set display features:



1) **Light**: display light setting:



- Use the MODE key to set display backlighting.

Select the Mode item with the arrow, and press ENTER to open the relevant submenu. The following screen is:



ON : Light always on

OFF : Light always off

AUTO: Automatic light setting. It turns on every time a key is pressed and stays on for 30 seconds then gradually turns off.

2) **Contrast:** display light contrast

Available display light tones go from 0 to 9.

Press UP and DOWN to scroll numbers and then press ENTER to confirm.

3) **Buzzer:** key tone setting

Selecting:

ON : key tone on

OFF : key tone off

5.5.6.3 Service

Only installing staff can gain access to this function, which is password-protected and dedicated code is supplied by Power-One.

5.5.6.4 New Password

This function is used to change the default password 0000.

To set your personal code, use the display keys as follows:

- Use ENTER to move from one digit to the next (from left to right)
- Use ESC to go back to the previous digit (from right to left)
- Press ESC repeatedly to go back to the previous menus as described in sect. 5.5.3
- Press DOWN to scroll numbers backwards (from 9 to 0)
- Press UP to scroll numbers from 0 to 9

5.5.6.5 Cash

This function is about energy output savings.

| | |
|----------------|--------------|
| Name | EUR |
| Val/KWh | 00.50 |

Name: set desired currency, using keys as usual. Default currency is Euro.

Val/KWh: it indicates the cost of 1 KWh expressed in set currency. Default setting is 0.50 Euro.

5.5.6.6 Time

This function allows time and date setting.

Time 14:21
Date 17 May 2006

5.5.6.7 Language

It is possible to set the national language or English.

→ English
Italiano

5.5.6.8 START Voltage

Start-up voltage can be set according to available photovoltaic system. Voltage range can be 120V to 350V. Default setting for Aurora is 200V. This parameter can be changed by means of the display keys.

VStart
200V

5.5.6.9 Autotest

Aurora internal test checking correct operation of the protection and the grid interface device, as provided for by national regulations.

Autotest

Press ENTER to access all information of this section:

→ OV test
UV test
OF test
UF test
DC injection

OV = Max. voltage

UV = Min. voltage

OF = Max. Frequency

UF = Min. Frequency

DC injection = Output current direct component. This component shall not be >0.5% with respect to inverter maximum rated current, or unit will switch off.

The display has 2 lines; use the keys at the side of the display to scroll through items or open the corresponding submenus.

An arrow on left side of the display highlights your current selection. When chosen item is selected, press ENTER to open the submenu.

As soon as test is selected, the display shows

| |
|----------------------------------|
| Test in progress |
|----------------------------------|

During the test the display gives test progress indication.

If test is passed, depending on selected item, the display shows:

| | |
|-------------|------------------|
| Test | V= V |
| OK | T=ms |

| | |
|-------------|------------------|
| Test | F=.... Hz |
| OK | T=ms |

| | |
|-------------|------------------|
| Test | I=.... mA |
| OK | T=ms |

V= measured voltage; T= time necessary to take the measurement

F= measured frequency; T= time necessary to take the measurement

While if test is failed, the following will be displayed:

| | |
|-------------|------------------|
| Test | V= V |
| Fail | T=ms |

| | |
|-------------|------------------|
| Test | F=.... Hz |
| Fail | T=ms |

| | |
|-------------|------------------|
| Test | I=.... mA |
| Fail | T=ms |

V= measured voltage; T= time necessary to take the measurement

F= measured frequency; T= time necessary to take the measurement

5.5.6.10 Alarm

The inverter features an alarm function that opens or closes a relay contact, access can be gained through front door as indicated in Fig. 22. This contact can be used for instance to activate a siren or a visual alarm in case inverter is disconnected from the grid (no energy output) or for any alarm event generated by the system.

This function can activate two alarm modes. Press ENTER to open the relevant submenu:



An arrow on left side of the display highlights your current selection. When chosen item is selected, press ENTER to confirm activation of chosen mode.

PRODUCTION: Relay is only activated when inverter is connected to the grid (contact closing across terminals “N.O.” and “C”)

FAULT: triggers relay activation (contact closing across terminals “N.O.” and “C”), only when an error signal occurs, i.e. when grid is disconnected, excluding Input Under Voltage.



Fig. 22: alarm contacts terminal block

5.5.6.11 Remote Control

This function is used to disable inverter manual switch-off. Operation is as follows:

- set to ENABLE to activate manual ON/OFF function
- set to DISABLE to disable manual ON/OFF function, so that Aurora operation will only depend on external solar radiation.



Manual ON and OFF input is read on inverter digital input. When set to OFF, the display will cycle through the following screens:

Remote OFF

**Waiting Rem.ON...
....to restart**

5.5.6.12 UV Prot.time

This function is used to set inverter connection time after input voltage drops below Under Voltage limit, set at 90V.

For example: if UV Prot.time is set at 60 seconds, and Vin voltage drops below 90V at 9.00, the inverter stays connected to the grid (at 0 power) up to 9.01.

Power-One sets this time at 60 seconds. The user can change this setting and set it from 1 second to 3600 seconds.

5.5.6.13 MPPT scan

This function is used to automatically detect input power max. multiples.

**MPPTscan En7Dis
Enable**

5.5.6.14 Scan Interval

This function is used to set time interval for system max.multiple scan. Default setting is 15 minutes.

**Scan Interval
15 min**

5.5.7 Info

This menu is used to display all Aurora data:

- Part No. (part number)
- Serial No. – Wk – Yr (serial number, week, year)
- Fw rel (firmware release level)

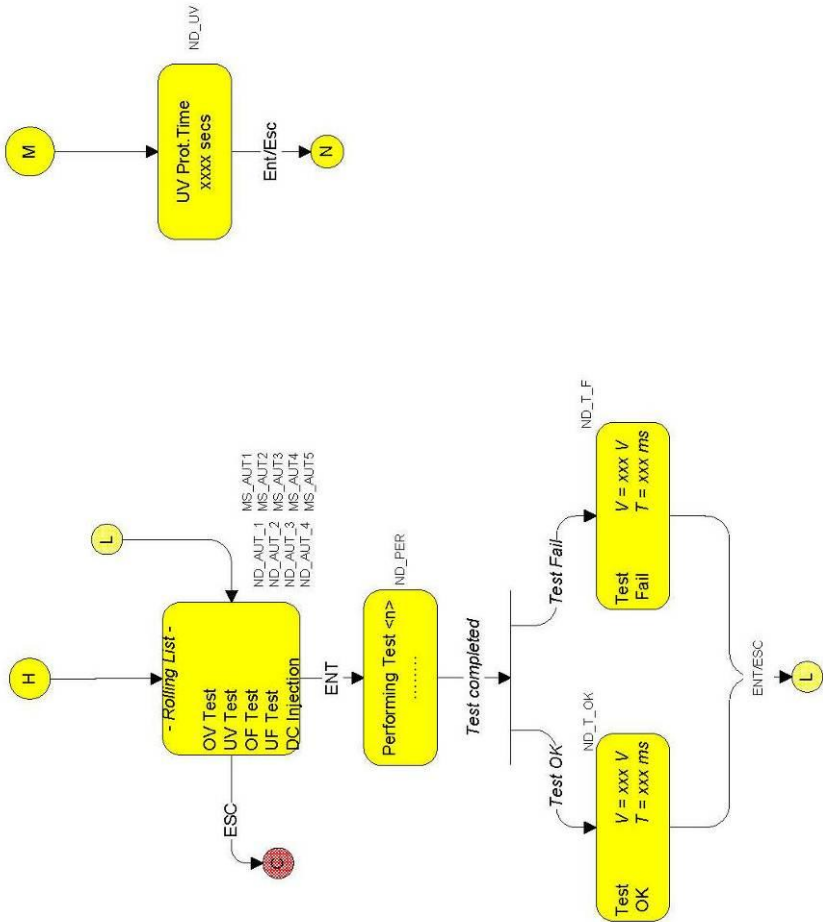

6. DATA CHECK AND COMMUNICATION

6.1. Connection through RS-485 serial port or RJ12 connectors

6.1.1 RS-485 serial port

RS-485 serial port uses a three-wire cable: two wires are for signals and the third one is for ground connection. Cable is routed through the holes located at Inverter bottom which are blanked with waterproof plugs (see Fig.23). Supplied cable gland must be installed in the suitable hole.



FIG.23

Holes for cables necessary for RS-485 port connection
or wiring for RJ12 connectors connection.

For easier installation, the inverter features two holes so that input and output cables can be separated in case more units are connected in a daisy chain as described below.

After passing through cable gland, cables are connected inside of the unit to RS-485 terminal blocks that can be reached by removing the front door. Refer to par. 3.7 for details on front cover correct removal and reassembly procedure.

- Signal wires must be connected to +T/R and –T/R terminals
- Ground wire must be connected to RTN terminal

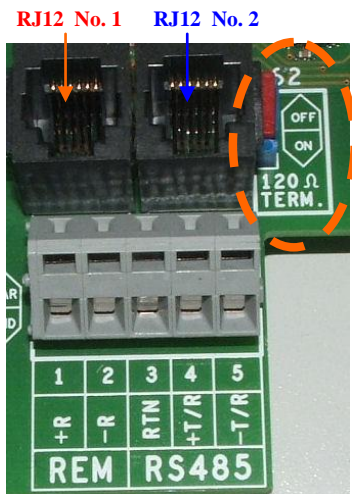

Fig.24 Terminals for connection to RS-485 serial line and S2 switch

6.1.2 RJ12 connectors

As an alternative to RS485 serial connection, be it as single units or as a daisy chain, inverter connection can be performed by means of RJ12 connectors (see fig. 24).

Wiring is again routed through the holes located at Inverter bottom which are blanked with waterproof plugs (see Fig.23). Input wiring passes through one hole and is to be assembled to one of the RJ12 connectors; it does not matter whether it is no. 1 or no. 2 since signals are the same considering that they are connected in parallel.

Output wiring goes out from the other RJ12 connector through the other hole and reaches the next unit.

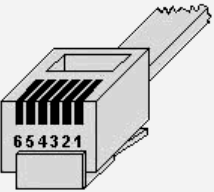
| RJ12 connectors | | | | |
|---|-------|-------------|----------------------|--|
|  RJ12 (6P6C) | Pin # | Signal Name | Description | |
| | 1 | | | Not Used |
| | 2 | +TR | + Data Line | Required for RS485 communication. |
| | 3 | +R | Remote OFF | Required or Remote OFF control (see chapter 5.5.6.11 for details). |
| | 4 | -TR | - Data Line | Required for RS485 communication. |
| | 5 | | | Not Used |
| | 6 | RTN | Signal Return | Common reference for logical signals. |

6.1.3 Daisy chain

RS-485 terminal block or RJ12 connectors can be used to connect a single AURORA inverter or many AURORA inverters connected in a daisy chain. Maximum number of inverters that can be connected in daisy chain is 248. Recommended maximum length of this chain is 1200 metres.

In case many inverters are connected in a daisy chain, it is necessary to assign an address to each unit. Refer to paragraph 5.5.6.1 for instructions on how to set addresses.

Moreover, the last inverter of the chain must have line termination contact active (S2 switch -120Ω TERM set to ON). See fig. 24.

Any AURORA device is supplied with default address two (2) and with the S1 dip switch in the OFF position.

In order to ensure optimum communication on RS485 line, Power-One recommends to connect PVI-RS232485 adapter in-between the first unit of the daisy chain and the computer. See fig. 25 for further details.

To this purpose other equivalent devices available on the market can also be used but Power-One does not assure correct connection operation since equipment has never been tested with these equivalent devices.

Please note that these commercial devices could require an external termination impedance, which is not necessary for Aurora PVI-232485.

The following diagram shows you how to connect many multiple units in daisy chain configuration.

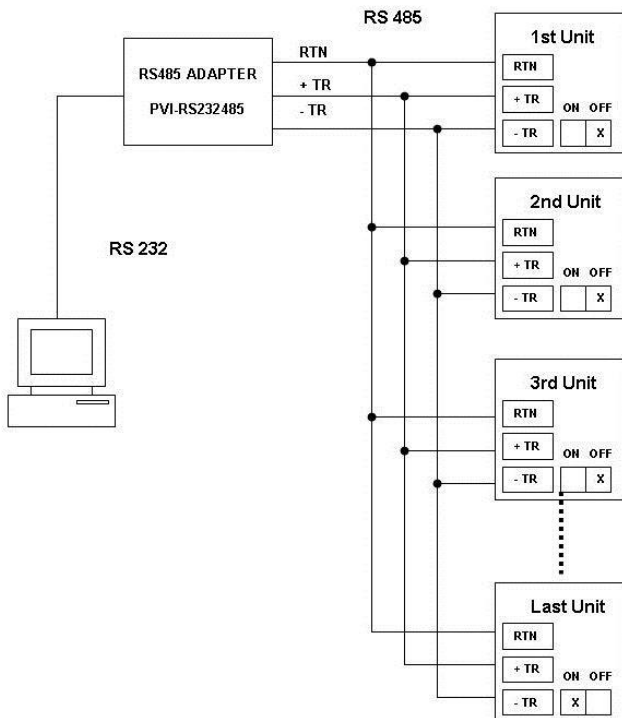

Fig. 25 Daisy chain multiple connection

NOTE: When using RS-485 link there can be up to 248 inverters connected on the same link. Choose any address between 2 and 248

NOTE: When using RS-485 link, in case one or more inverters are added later to the system, please remember to switch back to the OFF position the dip-switch of the former last inverter of the system.

6.2. Serial connection with USB port

Serial connection through USB port allows connection of a single inverter to a personal computer equipped with a USB 2.0 interface and dedicated software supplied by Power-One. PC-inverter connection cable is a standard USB 2.0 cable, 5 metre long, with terminals of the A and B type. Just remove the waterproof plug located on Aurora side to make the connection (see fig. 26).



Fig.26 USB connection

6.3. Measurement Accuracy

Every measure should consider possible errors.

The following tables show for each reading:

- measurement units;
- capacity;
- resolution.

| | Name of measured variable | Measurement unit | Resolution | | Maximum error percentage |
|----------------------|---------------------------|------------------|------------|-------|--------------------------|
| | | | Display | Value | |
| Input voltage PV N°1 | VP1 | Vdc | 1V | 600mV | 2% |
| Input voltage PV N°2 | VP2 | Vdc | 1V | 600mV | 2% |
| Input current PV N°1 | IP1 | Adc | 0.1A | 25mA | 2% |
| Input current PV N°2 | IP2 | Adc | 0.1A | 25mA | 2% |
| Output power PV N°1 | Pin1 | W | 1 W | 10 W | 2% |
| Output power PV N°2 | Pin2 | W | 1 W | 10 W | 2% |
| Output voltage | Vout | V | 1V | - | 2% |
| Output current | Iout | A | 0.1A | - | 2% |
| Output power | Pout | W | 1 W | - | 2% |
| Frequency | Freq | Hz | 0.01 | 0.01 | 0.1% |

| | Name of measured variable | Measurement unit | Resolution | | Maximum error percentage |
|----------------------|---------------------------|------------------|------------|-------|--------------------------|
| | | | Display | Value | |
| Accumulated energy | Energy | Wh | 1Wh | | 4% |
| Time counter | Lifetime | hh:mm:ss | 1s | | 0.2 |
| Partial time counter | Partial Time | hh:mm:ss | 1s | | 0.2 |

7. TROUBLESHOOTING

Aurora inverters comply with standards set for grid-tied operation, safety and electromagnetic compatibility.

Before being delivered, the product has been successfully subjected to several tests to check: operation, protective devices, performance and durability.

All these tests, together with the system ensuring Power-One quality, guarantee Aurora optimal operation.

In case of any possible malfunction of the inverter, solve problems as follows:

- ✓ Work under safe conditions, as stated in chapter 3.5 and following, check that connections between Aurora, photovoltaic field and power distribution grid have been made correctly.
- ✓ Carefully observe which LED is blinking and read the signal appearing on the display; then, following the instructions given in chapters 5.3, 5.4 and 5.5, try to identify the type of fault found.

If the malfunction cannot be removed by following these instructions, contact the service center or the installer (see following page).

Before contacting the service center, keep the following information handy:

INFO Aurora

NOTE: Information to be found directly on LCD

- ✓ Aurora model?
 - ✓ Serial number?
 - ✓ Week of production?
 - ✓ LED flashing?
 - ✓ Light blinking or steady?
 - ✓ Signal displayed?
-
- ✓ Malfunction short description?
 - ✓ Can malfunction be reproduced?
 - ✓ If so, how?
 - ✓ Does malfunction appear cyclically?
 - ✓ If so, how frequently?
 - ✓ Is malfunction present from installation?
 - ✓ If so, has it worsened?
 - ✓ Description of the atmospheric conditions when the malfunction appeared.

INFO on the Photovoltaic Field

- ✓ Make and model of photovoltaic panels
- ✓ System structure:
 - array max. voltage and current values
 - number of strings for the array
 - number of panels for each string

8. TECHNICAL FEATURES

8.1. Input Values



WARNING: the Photovoltaic field and system wiring must be configured in such a way that the PV input voltage is less than the maximum upper limit independently from the type, the number and the operating conditions of the chosen photovoltaic panels.

As panel voltage also depends on working temperature, the number of panels per string shall be chosen according to the min. ambient temperature expected in that special area (see table A).



WARNING: Inverter is provided with a linear output power derating depending on the input voltage, starting from 530 Vdc (100% output power) to 580 Vdc (0% output power)



WARNING: The open circuit voltage of the photovoltaic panels is affected by the ambient temperature (the open circuit voltage increases as the temperature decreases) you have to make sure that the minimum temperature estimated for the installation doesn't cause the panels to exceed the maximum upper limit of 600Vdc. As an example, the following table shows for typical panels of 36, 48 and 72 cells the maximum voltage of each panel as a function of the temperature (assuming a nominal open circuit voltage of 0.6Vdc per cell at 25°C and a temperature coefficient of $-0.0023\text{V}/^\circ\text{C}$). The table shows, therefore, the maximum number of panels that can be connected in series as a function of the minimum temperature at which the system will operate. Consult the panel manufacturer for the correct temperature coefficient of Voc, before calculating the maximum voltage of the photovoltaic array.

| Minimum Panel Temp.[°C] | 36 Cells Panels | | 48 Cells Panels | | 72 Cells Panels | |
|-------------------------|-----------------|----------------------|-----------------|---------------|----------------------|---------------|
| | Panel voltage | Max number of panels | Panel voltage | Panel voltage | Max number of panels | Panel voltage |
| 25 | 21.6 | 27 | 28.8 | 20 | 43.2 | 13 |
| 20 | 22.0 | 27 | 29.4 | 20 | 44.0 | 13 |
| 15 | 22.4 | 26 | 29.9 | 20 | 44.9 | 13 |
| 10 | 22.8 | 26 | 30.5 | 19 | 45.7 | 13 |
| 5 | 23.3 | 25 | 31.0 | 19 | 46.5 | 12 |
| 0 | 23.7 | 25 | 31.6 | 19 | 47.3 | 12 |
| -5 | 24.1 | 24 | 32.1 | 18 | 48.2 | 12 |
| -10 | 24.5 | 24 | 32.7 | 18 | 49.0 | 12 |
| -15 | 24.9 | 24 | 33.2 | 18 | 49.8 | 12 |
| -20 | 25.3 | 23 | 33.8 | 17 | 50.7 | 11 |
| -25 | 25.7 | 23 | 34.3 | 17 | 51.5 | 11 |

Table A

| Description | Value PVI – 6000-OUTD | |
|---|---|--------------------------|
| Recommended DC power | 6200W | |
| Nominal input voltage | 360Vdc | |
| Max. absolute input voltage | 600Vdc | |
| Input voltage, MPPT operating range | 90 Vdc to 580 Vdc | |
| Input voltage, MPPT operating range at full power | 180 Vdc to 530 Vdc | |
| Max. short circuit current (of each array) | 22 Adc | |
| Max. operating input current (of each array) | 18 Adc | |
| Max. input power (of each array) (*) | 4000 W | |
| PV Ground fault protection | Ground fault detector and interruption provided | |
| Input channels configuration (array) | Two independent MPPT channel with shared negative poles | Two channels in parallel |

(*) Total DC power input must always be below the recommended DC power



NOTE: If the input current supplied by the photovoltaic field connected to the inverter is above the max. value and the input voltage is within the allowed range, the inverter is not damaged.

8.2. Output Values

| Description | Value PVI – 6000-OUTD |
|---|---|
| Nominal output power | 6000 W |
| Grid voltage, maximum range | 200 to 270 Vac |
| Grid voltage, nominal | 230 Vac |
| Grid voltage, operating range as per AS4777 | from 89% to 115% of nominal voltage (from 205 to 264Vac for $V_{nom}=230Vac$) |
| Grid frequency, maximum range | 45 to 55 Hz |
| Grid frequency, nominal | 50 Hz |
| Grid frequency, operating range as per AS4777 | 47.1 to 52.9 Hz |
| Nominal output current | 26 Arms |
| Max. output current | 30 Arms |
| Output over current protection | 40 Arms |

8.3. Grid protection characteristics

| | |
|---------------------------|------------------------------------|
| Anti islanding protection | Complies with: - AS4777.3-2005. |
|---------------------------|------------------------------------|

8.4. General characteristics

| Description | Value PVI – 6000-OUTD |
|---------------------------------------|------------------------------|
| Maximum efficiency | 97% (>96 Euro) |
| Internal consumption during stand-by | < 8 W |
| Internal consumption during nighttime | < 1 W |
| Operating ambient temperature | -25°C to +60°C (*) |
| Casing protection rating | IP65 / Nema 4X |
| Audible noise with internal fan on | < 50 dbA @ 1m |
| Size (height x width x depth): | 740 x 325 x 190 mm |
| Weight | 27 kg |
| Relative Humidity | 0 – 100 % condensation point |

(*) Full power guaranteed up to T.amb = 40°C (as far as unit is not exposed to direct sun radiation)

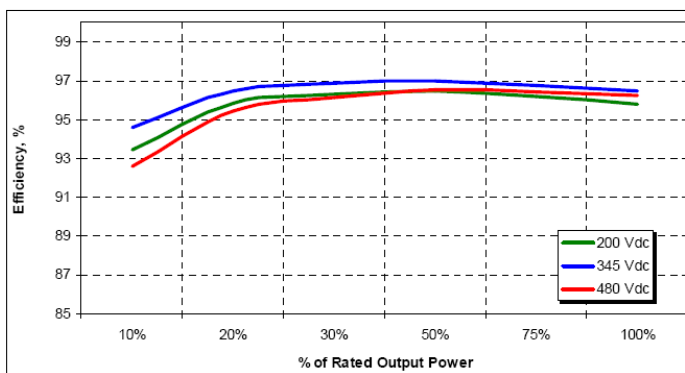

FIG.28 Efficiency plot

8.5. Power Derating

In order to ensure inverter operation under safe conditions both from the temperature and electrical point of view, the unit automatically decreases power input in the distribution grid.

Power derating can occur in two cases:

Power reduction due to environmental conditions

Power reduction and temperature at which it occurs depend on many operating parameters other than ambient temperature, such as input voltage, grid voltage and power available from the photovoltaic panels. AURORA can thus decrease power output during certain periods of the day according to these parameters.

In any case, AURORA ensures top power up to 40°C ambient temperature, as far as it is not directly exposed to the sun.

Power reduction due to input voltage

The graph shows automatic power output derating when input or output voltage is too high or too low.

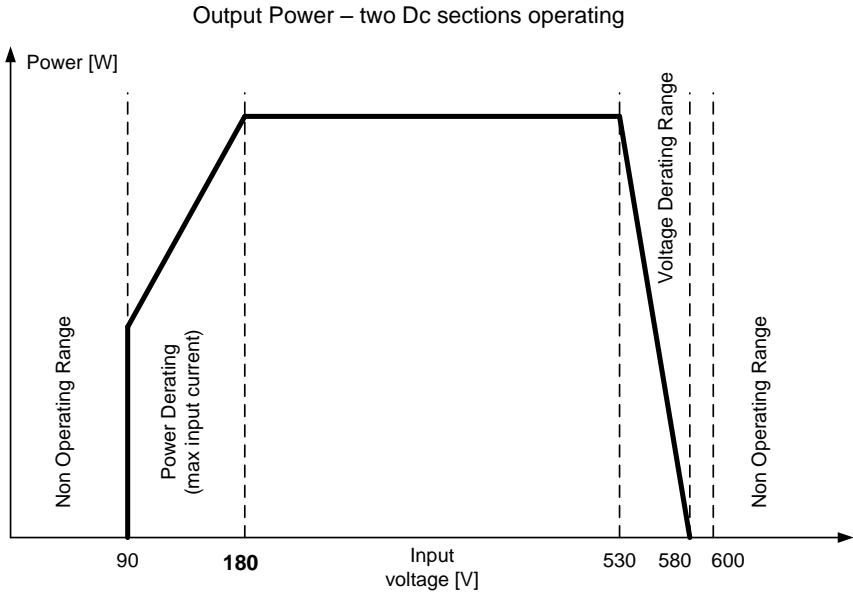

FIG.29

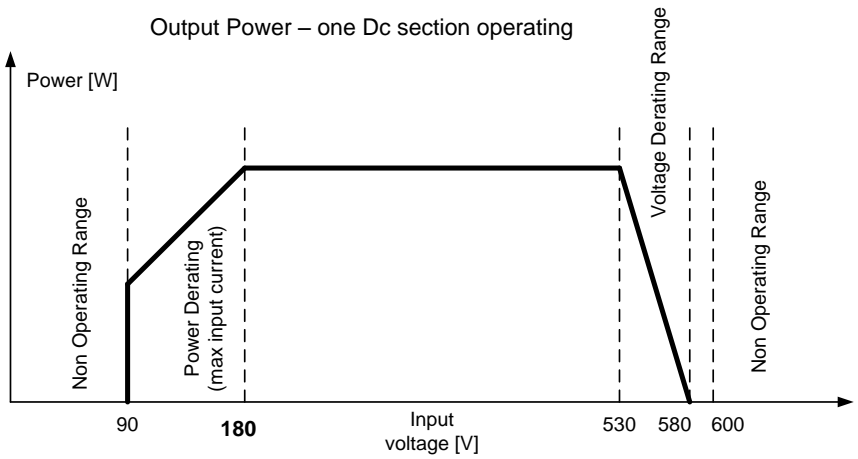

FIG.30

Necessary conditions for power derating due to environmental conditions and to input voltage can occur at the same time, but in this instance power derating will always consider the lowest value detected.

*******CERTIFICATE OF CONFORMITY*******



Certificate Number: CS9220N

Certificate of Suitability

This is to certify that articles of the same type as the article specified below and variations so specified are accepted by the OFFICE OF FAIR TRADING as suitable for connection to public electricity supply in NEW SOUTH WALES in accordance with the provisions of AS/NZS 3000 and subject to the condition stated.

Article:

Solar Grid Connected Inverter

Input:

System Voltage: 600Vdc Max.

Operating Voltage Range: 90-580Vdc

Maximum Operating Current: 18A

Max Array Short Circuit Current: 22A

Output:

Operating Voltage: 230V,ac

Continuous Output Current

Current: 30A

Max Cont Power@50°C: 6kW

Max Output Overcurrent

Protection:35A

Trade Name or Mark: 'Aurora'

Volts:

Watts:

Other Name Plate Particulars: Op Amb Temp: -25°C..+60°C

Degree Of Protection: IP65; Protection Class I

Amperes:

Hertz: 50 Hz

Identification: PVI-6000-OUTD-S-AU

**Examined for compliance with: AS4777.2 & 3 : 2005; AS/NZS 3100: 2002 A1-3
AS/NZS 60950 : 2003 A1-3**

Issued to: Power- One Energy Solutions Pty Ltd

Nominated Marking: CS9220N;

Conditions:

1. This certification will be withdrawn automatically if an article of this type is declared pursuant to the Electricity (Consumer Safety) Act, 2004.
2. This certificate is issued subject to the article and approved variations being maintained at the standard of the article examined at the time of approval.

Approved: 09/11/2009

This approval expires 09/11/2014 unless suspended, cancelled, renewed or extended.

A handwritten signature in black ink, appearing to be 'L. J. ...', written over a faint circular stamp.

for Commissioner for Fair Trading



Ref. CS9220N

ADDENDUM TO CERTIFICATE OF SUITABILITY CS9220N

Particulars of Modification(s)

The following Model Nos. being similar to original Model No. PVI-6000-OUTD-S-AU except as follows:-

- (a) PVI-6000-OUTD-AU : Without DC Integrated Switch.
- (b) PVI-5000-OUTD-AU : Output rating of 5000W in lieu of 6000W and without the DC Integrated Switch.
- (c) PVI-5000-OUTD-S-AU : Output rating of 5000W in lieu of 6000W and with DC Integrated Switch.
- (d) PVI-4.2-OUTD-AU : Output rating of 4200W in lieu of 6000W and without DC Integrated Switch.
- (e) PVI-4.2-OUTD-S-AU : Output Rating of 4200W in lieu of 6000W and with DC Integrated Switch.
- (f) PVI-3.6-OUTD-AU : Output Rating of 3600W in lieu of 6000W and without DC Integrated Switch.
- (g) PVI-3.6-OUTD-S-AU : Output Rating of 3600W in lieu of 6000W and with DC Integrated Switch.
- (h) PVI-6000-OUTD-AU-W : Designed for use with Wind Turbines in lieu of a Photovoltaic Array.

Model No. PVI-3.6-OUTD-AU-W being similar to Model No. PVI-4.2-OUTD-S-AU except being designed for Wind Turbines in lieu of a Photovoltaic Array and an Output Rating of 3600W.

Approved: 09 November 2009

A handwritten signature in black ink, appearing to be 'R. L.' or similar.

for Commissioner for Fair Trading