

***THERMAL PRINTER***

**TSP800 SERIES**

***USER'S MANUAL***

***MODE D'EMPLOI***

***BEDIENUNGSANLEITUNG***

***MANUALE DI ISTRUZIONI***

**star** 

**Federal Communications Commission  
Radio Frequency Interference  
Statement**

This equipment has been tested and found to comply with the limits for a Class A digital device, pursuant to Part 15 of the FCC Rules. These limits are designed to provide reasonable protection against harmful interference when the equipment is operated in a commercial environment. This equipment generates, uses and can radiate radio frequency energy and, if not installed and used in accordance with the instruction manual, may cause harmful interference to radio communications. Operation of this equipment in a residential area is likely to cause harmful interference in which case the user will be required to correct the interference at his own expense.

For compliance with the Federal Noise Interference Standard, this equipment requires a shielded cable.

*This statement will be applied only for the printers marketed in U.S.A.*

**Statement of  
The Canadian Department of Communications  
Radio Interference Regulations**

This digital apparatus does not exceed the Class A limits for radio noise emissions from digital apparatus set out in the Radio Interference Regulations of the Canadian Department of Communications.

Le présent appareil numérique n'émet pas de bruits radioélectriques dépassant les limites applicables aux appareils numériques de la classe A prescrites dans le Règlement sur le brouillage radioélectrique édicté par le ministère des Communications du Canada.

*The above statement applies only to printers marketed in Canada.*

**CE  
Manufacturer's Declaration of Conformity**

***EC Council Directive 89/336/EEC of 3 May 1989***

This product, has been designed and manufactured in accordance with the International Standards EN 50081-1/01.92 and EN 50082-1/01.92, following the provisions of the Electro Magnetic Compatibility Directive of the European Communities as of May 1989.

***EC Council Directive 73/23/EEC and 93/68/EEC of 22 July 1993***

This product, has been designed and manufactured in accordance with the International Standards EN 60950, following the provisions of the Low Voltage Directive of the European Communities as of July 1993.

*The above statement applies only to printers marketed in EU.*

***Trademark acknowledgments***

**TSP800, DP8340:** Star Micronics Co., Ltd.

**ESC/POS:** Seiko Epson Corporation

***Notice***

- All rights reserved. Reproduction of any part of this manual in any form whatsoever, without STAR's express permission is forbidden.
- The contents of this manual are subject to change without notice.
- All efforts have been made to ensure the accuracy of the contents of this manual at the time of going to press. However, should any errors be detected, STAR would greatly appreciate being informed of them.
- The above notwithstanding, STAR can assume no responsibility for any errors in this manual.

# TABLE OF CONTENTS

<b>1. Parts Identification and Nomenclature .....</b>	<b>1</b>
<b>2. Consumable Parts and AC Adapter .....</b>	<b>3</b>
<b>3. Connecting Cables and AC Adapter .....</b>	<b>5</b>
3-1. Interface Cable .....	5
3-2. Connecting to a Peripheral Unit .....	7
3-3. Connecting the Optional AC Adapter .....	8
3-4. Turning Power On .....	9
<b>4. Control Panel and Other Functions .....</b>	<b>10</b>
4-1. Control Panel .....	10
4-2. Errors .....	10
4-3. Self Printing .....	12
<b>5. Loading the Roll Paper .....</b>	<b>14</b>
<b>6. Adjusting the Near-end Sensor .....</b>	<b>16</b>
<b>7. Preventing and Clearing Paper Jams .....</b>	<b>18</b>
7-1. Preventing Paper Jams .....	18
7-2. Removing Paper Jam .....	18
<b>8. Periodical Cleaning .....</b>	<b>19</b>
8-1. Cleaning the Thermal Head .....	19
8-2. Cleaning the Paper Holder .....	19
<b>Appendix A: Specifications .....</b>	<b>80</b>
A-1. General Specifications .....	80
A-2. Auto Cutter Specifications .....	81
A-3. Interface .....	81
A-4. Electrical Characteristics .....	81
A-5. Environmental Requirements .....	82
A-6. Reliability .....	82
A-7. Black mark specifications .....	83
<b>Appendix B: Dip Switch Setting .....</b>	<b>84</b>
B-1. Parallel Interface Type .....	85
B-2. Serial Interface Type .....	87
<b>Appendix C: Parallel Interface .....</b>	<b>90</b>
<b>Appendix D: Serial Interface .....</b>	<b>91</b>
D-1. RS-232C Connector .....	91
D-2. Cable Connections .....	92
D-3. Electrical Characteristics .....	92
<b>Appendix E: Periheral Unit Drive Circuit .....</b>	<b>93</b>
<b>Appendix F: Memory Switch Settings .....</b>	<b>94</b>

Please access the following URL

[http://www.star-micronics.co.jp/service/sp\\_sup\\_e.htm](http://www.star-micronics.co.jp/service/sp_sup_e.htm)

for the latest revision of the manual.

# 1. Parts Identification and Nomenclature

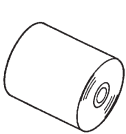
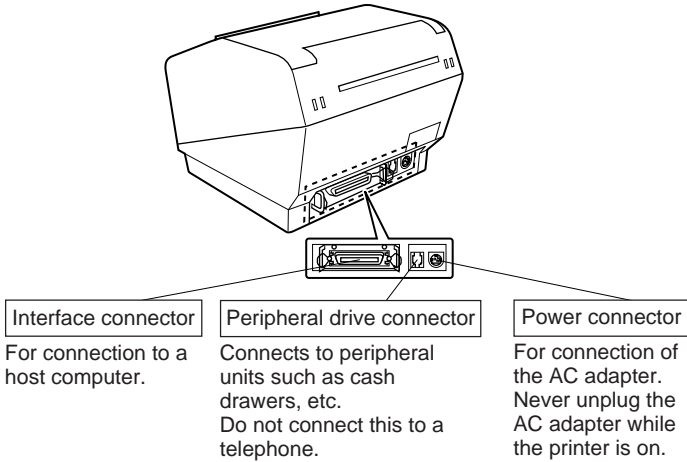
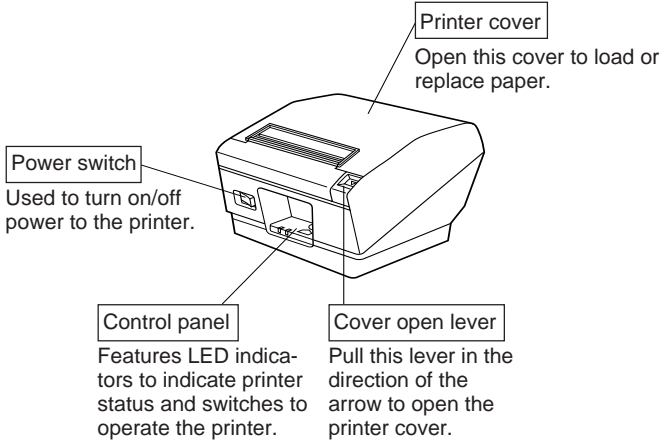

Roll paper



User's manual



Ferrite core  
(Parallel interface model only)



Fastener  
(Parallel interface model only)

## *Choosing a place for the printer*

Before actually unpacking the printer, you should take a few minutes to think about where you plan to use it. Remember the following points when doing this.

- ✓ Choose a firm, level surface where the printer will not be exposed to vibration.
- ✓ The power outlet you plan to connect to for power should be nearby and unobstructed.
- ✓ Make sure that the printer is close enough to your host computer for you to connect the two.
- ✓ Make sure that the printer is not exposed to direct sunlight.
- ✓ Make sure that the printer is well away from heaters and other sources of extreme heat.
- ✓ Make sure that the surrounding area is clean, dry, and free of dust.
- ✓ Make sure that the printer is connected to a reliable power outlet. It should not be on the same electric circuit as copiers, refrigerators, or other appliances that cause power spikes.
- ✓ Make sure that the room where you are using the printer is not too humid.

## 2. Consumable Parts and AC Adapter

When consumable parts have run out, use those specified in the table below. Make sure that the AC adapter specified in the table is used.

Use of consumable parts or AC adapter which are not specified in the table may result in damage to the printer, fire or electric shock.

### (1) Roll paper specification

Thermal paper

Thickness: 65~150  $\mu\text{m}$

Width: 111.5 $\pm$ 0.5 mm

Outer roll diameter:  $\phi$ 100 mm or less

Take up paper roll width: 112<sup>+0.3</sup><sub>-1</sub> mm

Core outer/inner diameter

Paper thickness	Core outer	Core inner
65~75 $\mu\text{m}$	$\phi$ 18 $\pm$ 1 mm	$\phi$ 12 $\pm$ 1 mm
65~75 $\mu\text{m}$	$\phi$ 32 $\pm$ 1 mm	$\phi$ 25.4 mm
75~150 $\mu\text{m}$	$\phi$ 32 $\pm$ 1 mm	$\phi$ 25.4 mm

Printed surface: Outer edge of roll

Tail end handling: Do not use paste or glue to secure the roll paper or its core.

Do not fold the tail end of the paper.

### (2) Recommended paper

Mitsubishi Paper Mills Limited

P220AG (normal type paper), 65  $\mu\text{m}$  (thickness)

HP220A (high image stability paper), 65  $\mu\text{m}$  (thickness)

HP220AB-1 (high image stability paper), 75  $\mu\text{m}$  (thickness)

P220AB (normal type paper, card ticket), 85  $\mu\text{m}$  (thickness)

P220AC-1 (normal type paper, card ticket), 95  $\mu\text{m}$  (thickness)

P220AC (normal type paper, card ticket), 105  $\mu\text{m}$  (thickness)

P220AD (normal type paper, card ticket), 130  $\mu\text{m}$  (thickness)

P220AE-1 (normal type paper, card ticket), 150  $\mu\text{m}$  (thickness)

Oji Paper Co., Ltd.

PD150R (normal type paper), 75  $\mu\text{m}$  (thickness)

PD160R (high image stability paper), 65/75  $\mu\text{m}$  (thickness)

Nippon Paper Industries

TF50KS-E2C (normal type paper), 65  $\mu\text{m}$  (thickness)

Depending on the type and thickness of the paper, it may be necessary to change the settings for printing darkness. To change the darkness settings, use the printing darkness settings command <ESC><RS> 'd' n. Refer to the separate programmer's manual for details.

(3) AC adapter (option)

Model name: PS60-24 A

Input: 100 to 240 V AC, 50/60 Hz

Output: DC24±5%, 2.0 A (5.0 A Load 10 sec. Max)

---

***Important!***

*Access the following URL for the information of the recommended paper.*

*<http://www.star-micronics.co.jp/>*

---

# 3. Connecting Cables and AC Adapter

## 3-1. Interface Cable

### 3-1-1. Ferrite Core Installation (Parallel interface model only)

- (1) For only the parallel interface model, affix the ferrite core onto the cable as shown in the illustration below.

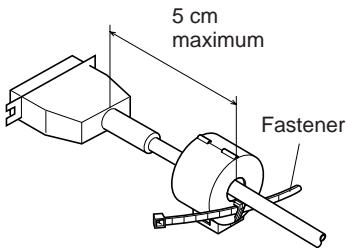
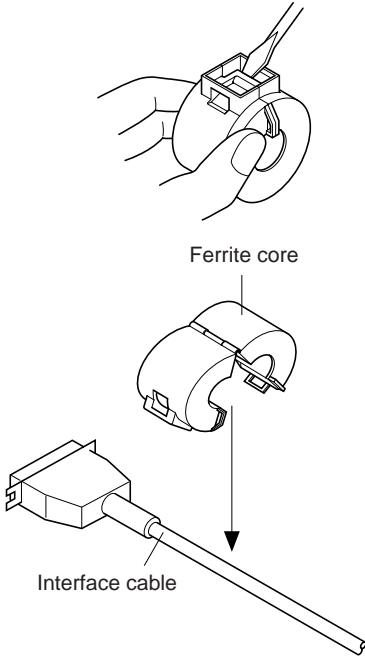

- (2) Pass the fastener through the ferrite core.

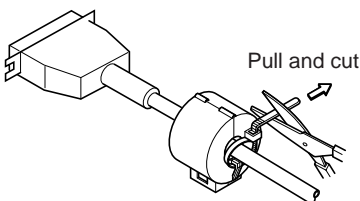

- (3) Loop the fastener around the cable and lock it. Use scissors to cut off any excess.



### 3-1-2. Connecting the Interface Cable

**Note:** Before connecting/disconnecting the interface cable, make sure that power to the printer and all the devices connected to the printer is turned off. Also make sure the power cable plug is disconnected from the AC outlet.

- (1) Connect the interface cable to the connector on the rear panel of the printer.
- (2) In the case of a serial interface, tighten the connector screws. In the case of a parallel interface, fasten the connector clasps.

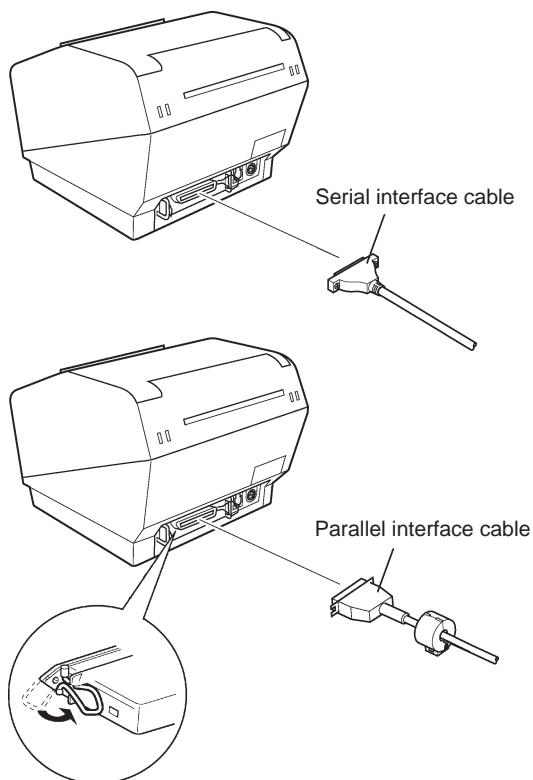

## 3-2. Connecting to a Peripheral Unit

You can connect a peripheral unit to the printer using a modular plug. The following describes how to install the ferrite core and make the actual connection. See “Modular plug” on page 80 for details about the type of modular plug that is required. Note that this printer does not come with a modular plug or wire, so it is up to you to obtain one that suits your needs.

### ***Important!***

Make sure that the printer is turned off and unplugged from the AC outlet and that the computer is turned off before making connections.

- (1) Connect the peripheral drive cable to the connector on the rear panel of the printer.

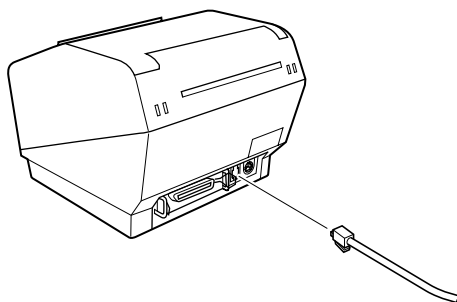

### 3-3. Connecting the Optional AC Adapter

**Note:** Before connecting/disconnecting the AC adapter, make sure that power to the printer and all the devices connected to the printer is turned off. Also make sure the power cable plug is disconnected from the AC outlet.

(1) Connect the AC adapter to the power cable.

**Note:** Use only the standard AC adapter and power cable.

(2) Connect AC adapter to the connector on the printer.

(3) Insert the power cable plug into an AC outlet.

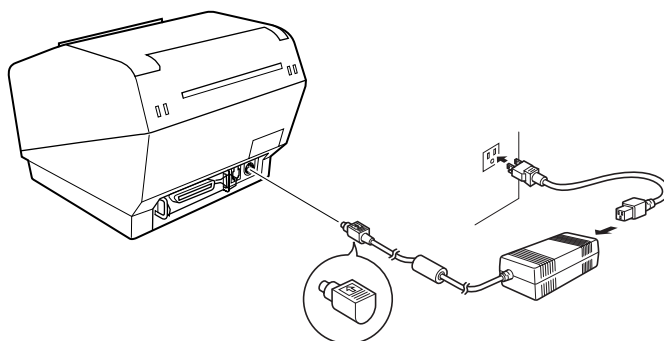

### 3-4. Turning Power On

Make sure that the AC adapter has been connected as described in 3-3.

- (1) Set the power switch located on the front of the printer to on.  
The POWER lamp on the control panel will light up.

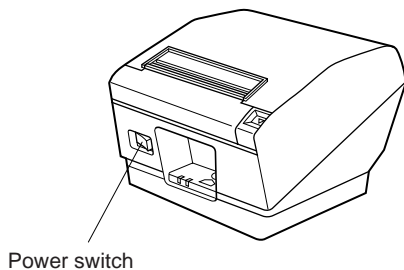

---

#### ***Important!***

*We recommend that you unplug the printer from the power outlet whenever you do not plan to use it for long periods. Because of this, you should locate the printer so that the power outlet it is plugged into is nearby and easy to access.*

---

## 4. Control Panel and Other Functions

### 4-1. Control Panel

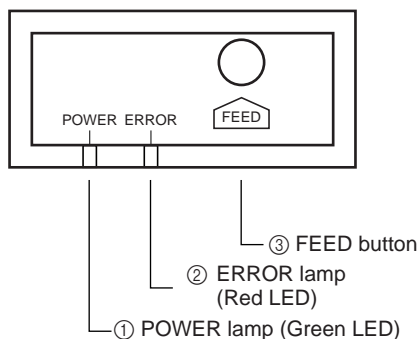

- ① POWER lamp (Green LED)  
Lights when the power is ON
- ② ERROR lamp (Red LED)  
Indicates various errors in combination with POWER lamp
- ③ FEED button  
Press the FEED button to feed roll paper.

### 4-2. Errors

#### 1) Automatically recoverable error

Error Description	POWER lamp	ERROR lamp	Recovery Conditions
Head high temperature detection	Flashes at 0.5 second intervals	Off	Automatically recovered after the print head has cooled.
Cover open error	On	On	Automatically recovered by closing the printer cover.

#### 2) Recoverable error

Error Description	POWER lamp	ERROR lamp	Recovery Conditions
Paper cut error	Off	Flashes at 0.125 second intervals	Recovered If the cutter returns to the home position after turning the power OFF and ON.

#### Note

- 1) If the cutter doesn't return to the home position, or doesn't perform the initial movement, it cannot be recovered.
- 2) If the paper is jammed, turn the power off, clear the jammed paper, then turn the power ON.

## 3) Non recoverable error

Error Description	POWER lamp	ERROR lamp	Recovery Conditions
RAM error	Off	On	This is not a recoverable error. Consult dealer for repairs.
EPROM error	Flashes at 0.25 second intervals	Flashes at 0.25 second intervals	This is not a recoverable error. Consult dealer for repairs.
Thermistor error	Flashes at 0.5 second intervals	Flashes at 0.5 second intervals	
Power supply error	Flashes at 1 second intervals	Flashes at 1 second intervals	This is not a recoverable error. Consult dealer for repairs.

**Note**

- 1) If a non recoverable error occurs, turn the power OFF immediately.
- 2) When Power supply error occurs, there is a possibility that the power supply unit has a trouble.

For other non recoverable errors, please consult the dealer for repairs.

## 4) Paper detection error

Error Description	POWER lamp	ERROR lamp	Recovery Conditions
Paper out error	On	Flashes at 0.5 second intervals	Automatically recovered by loading a new paper roll, then closing the printer cover.
Paper near end	On	Flashes at 0.2 second intervals	Indicators show that the paper end is approaching, but the printer continues to print.

## 4-3. Self Printing

### (1) Test Printing

Turn the power on while holding the FEED button depressed.

Test printing will be performed according to the Ver. No., DIP switch settings and character order. When the FEED button is depressed at the time of the end of test printing, only the characters will be printed out repeatedly.

```
*** TSP800 Ver1.00
```

```
Interface : Parallel
```

```
DIP Switch 1
```

```
Sw 12345678
```

```
On 00000000
```

```
Off
```

```
1,2 = Emulation : Star Line
```

```
4 = Sensor Adjustment : Off
```

```
5 = INIT Reset : Enable
```

```
6 = BUSY : All
```

```
7 = ASB : Disable
```

```
Memory Switch
```

```
FEDCBA9876543210 HEX.
```

```
<0> 0000000000000000 0000
```

```
<1> 0000000000000000 0000
```

```
0123456789; ;<=>?@ABCDEF
./0123456789; ;<=>?@ABCDEF
-./0123456789; ;<=>?@ABCDEF
./0123456789; ;<=>?@ABCDEF
./0123456789; ;<=>?@ABCDEF
/0123456789; ;<=>?@ABCDEF
0123456789; ;<=>?@ABCDEF
123456789; ;<=>?@ABCDEF
23456789; ;<=>?@ABCDEF
3456789; ;<=>?@ABCDEF
456789; ;<=>?@ABCDEF
56789; ;<=>?@ABCDEF
```

## (2) Hexadecimal Dump Mode

Open the printer cover, then turn the power on while holding the FEED button. When the cover is closed, “\*\*\* HEX DUMP PRINTING \*\*\*” is printed, and the printer enters the Hexadecimal Dump Mode.

Each of the signals sent from the computer to the printer will be printed out in hexadecimal code.

This function allows you to check if a control code sent to the printer by the program being used is correct or not. The final line is not printed if its data is less than one full line. However, if the FEED button is pushed, the final line is printed. To turn off the mode, it is necessary to turn off the printer completely.

\*\*\* HEX DUMP PRINTING \*\*\*

20 21 22 23 24 25 26 27	!'"#\$%&'
28 29 2A 2B 2C 2D 2E 2F	()*+,-./
30 31 32 33 34 35 36 37	01234567
38 39 3A 3B 3C 3D 3E 3F	89:;<=>?
40 41 42 43 44 45 46 47	@ABCDEFG
48 49 4A 4B 4C 4D 4E 4F	HJKLMNO
50 51 52 53 54 55 56 57	PQRSTUVWXYZ



## 5. Loading the Roll Paper

Be sure to use roll paper that matches the printer's specification.

Push the Cover open lever, and open the printer cover.

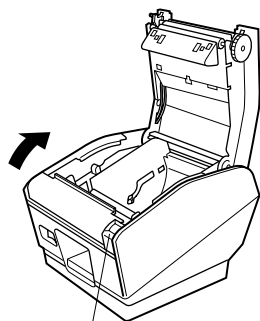

Cover open lever

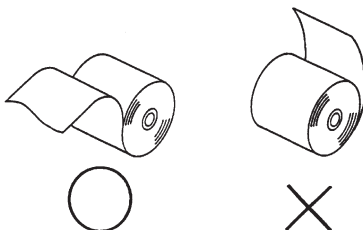

While observing the direction of the roll, set the paper roll into the hollow, and pull on the leading edge of the paper toward you.

Roll paper

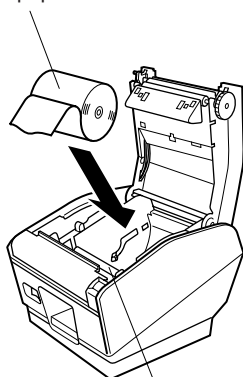

Tension bar

**Note 1:** When you use a paper of the thickness which needs the tension bar ( $65 \mu\text{m} \leq \text{paper thickness} < 100 \mu\text{m}$ ), make sure not to pass the paper under the tension bar.

**Note 2:** When you use a paper of the thickness which doesn't need the tension bar ( $100 \mu\text{m} \leq \text{paper thickness} \leq 150 \mu\text{m}$ ), please remove two screws at both sides of the tension bar with a screwdriver, and remove the tension bar unit in advance. Ordinarily, this procedure (removal of the tension bar) should already have been done by your dealer.

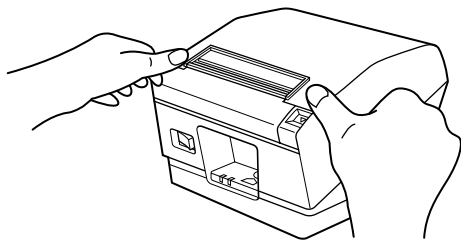

Push down both sides of the printer cover to close.

**Note:** Make sure that the printer cover is securely closed.

---

### **Important!**

1. *Do not touch the cutter blade.*
    - *There is a cutter inside the paper outlet slot. Not only should you not put your hand in the paper outlet slot while printing is in progress, never put your hand into the outlet even when printing is not in progress.*
    - *The printer cover can be opened when replacing the paper. However, since the cutter blade is on the inside of the printer cover, be careful not to place your face or hands too close to the cutter blade.*
  2. *Do not operate the cover open lever while pressing on the printer cover with your hand.*
  3. *Do not pull out paper while the printer cover is closed.*
  4. *The heating element and the driver IC of the thermal head are easily damaged. Do not touch them with metal objects, sandpaper, etc.*
  5. *During and immediately after printing, the area around the thermal head is very hot. Do not touch it, as you could be burned.*
  6. *Printing quality may suffer if the thermal head heating element becomes soiled by being touched with your hands. Do not touch the thermal head heating element.*
  7. *There is a risk of damage to the driver IC of the thermal head from static electricity. Please exercise caution.*
  8. *The printing quality and working life of the thermal head cannot be guaranteed if any paper other than that recommended is used. In particular, paper containing [Na<sup>+</sup>, K<sup>+</sup>, Cl<sup>-</sup>] may drastically reduce the working life of the thermal head. Please exercise caution.*
  9. *Do not operate the printer if there is moisture on the front surface of the head from condensation, etc.*
-

## 6. Adjusting the Near-end Sensor

Use the following procedure to adjust the near-end sensor so it is compatible with the size of roll paper you are using.

- ① Open the printer cover.
- ② Determine the diameter of the roll paper you are using and find the required setting in the table below.
- ③ Insert the tip of a ballpoint pen or similar pointer object into the hole of the adjuster. While pressing the adjuster, slide it up or down to the setting that matches the roll paper you are using.

Make sure the tab indicated by the arrow in the illustration is inside one of the grooves.

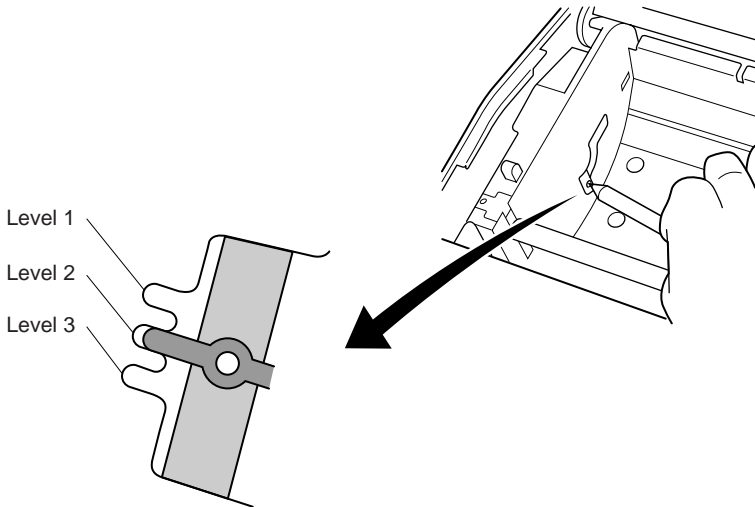

Adjustment value according to the paper you are using

Paper thickness ( $\mu\text{m}$ )	When using the paper roll with a core whose inside diameter (A): $\phi$ 12, outside diameter (B): $\phi$ 18					
	Detected diameter (C) (Approx. mm)			Remained paper length (Approx. m)		
	Level 1	Level 2	Level 3	Level 1	Level 2	Level 3
65	$\phi$ 23	$\phi$ 27	$\phi$ 31	2.5	4.9	7.7
75				2.1	4.2	6.7

Paper thickness ( $\mu\text{m}$ )	When using the paper roll with a core whose inside diameter (A): $\phi$ 25.4, outside diameter (B): $\phi$ 32					
	Detected diameter (C) (Approx. mm)			Remained paper length (Approx. m)		
	Level 1	Level 2	Level 3	Level 1	Level 2	Level 3
65	$\phi$ 36	$\phi$ 40	$\phi$ 44	2.8	6.4	10.4
75				2.4	5.5	9.0
85				2.1	4.9	7.9
95				1.9	4.4	7.1
105				1.7	4.0	6.4
130				1.4	3.2	5.2
150				1.2	2.8	4.5

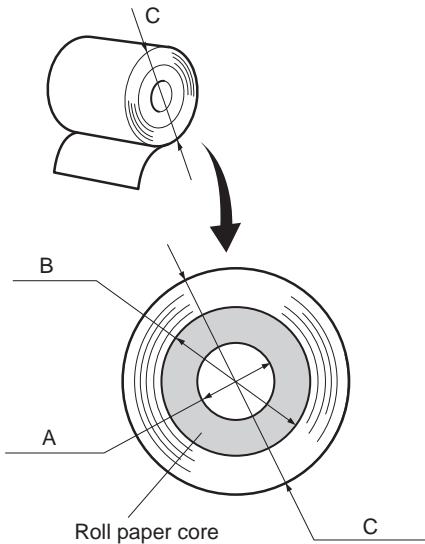

**Note**

- 1) The adjuster is set at level 1 with the factory setting.
- 2) The C dimension and the remained paper length are the calculated values. There may be some variations in actual mechanism.

## 7. Preventing and Clearing Paper Jams

### 7-1. Preventing Paper Jams

The paper should not be touched during ejection and before it is cut. Pressing or pulling the paper during ejection may cause a paper jam, paper cutting failure or line feed failure.

### 7-2. Removing Paper Jam

If a paper jam occurs, clear it as described below.

- (1) Set the power switch to off to turn off power to the printer.
- (2) Pull the lever toward you to open the printer cover.
- (3) Remove the jammed paper.  
**Note:** Take care not to damage the printer when removing the jammed paper. Since it is easy to damage the thermal head in particular, take care not to touch it.
- (4) Position the roll paper straight and close the printer cover gently.  
**Note 1:** Make sure that the paper is positioned straight. If the printer cover is closed with the paper skewed, a paper jam may result.  
  
**Note 2:** Lock the printer cover by pressing down on the sides. Do not try to close it by pressing down on the center. The cover may not lock properly.
- (5) Set the power switch to on to turn on power to the printer. Make sure that the ERROR LED is not lit.  
**Note:** While the ERROR LED is lit, the printer will not accept any commands such as the print command, so make sure that the printer cover is locked properly.

## 8. Periodical Cleaning

Printed characters may become partially unclear due to accumulated paper dust and dirt. To prevent such a problem, paper dust collected in the paper holder and paper transport section and on the surface of the thermal head must be removed periodically. Such cleaning is recommended to be carried out once six month or one million lines.

### 8-1. Cleaning the Thermal Head

To remove blackish dust collected on the surface of the thermal head, wipe it with alcohol (IPA).

**Note:** The thermal head is easy to damage, so clean it gently with a soft cloth. Take sufficient care not to scratch it when cleaning it.

### 8-2. Cleaning the Paper Holder

Use a soft cloth to remove paper dust from the paper holder and paper transport section.

# TABLE DES MATIERES

<b>1. Identification des pièces et nomenclature .....</b>	<b>21</b>
<b>2. Consommables et adaptateur secteur .....</b>	<b>23</b>
<b>3. Câbles de connexion et adaptateur secteur .....</b>	<b>25</b>
3-1. Câble d'interface .....	25
3-2. Raccordement d'un appareil périphérique .....	27
3-3. Connexion de l'adaptateur secteur optionnel .....	28
3-4. Mise sous tension de l'imprimante .....	29
<b>4. Panneau de commande et autres fonctions .....</b>	<b>30</b>
4-1. Panneau de commande .....	30
4-2. Erreurs .....	30
4-3. Auto-impression .....	32
<b>5. Chargement du rouleau de papier .....</b>	<b>34</b>
<b>6. Réglage du capteur de fin de rouleau .....</b>	<b>36</b>
<b>7. Prévention et correction de bourrages de papier .....</b>	<b>38</b>
7-1. Prévention des bourrages de papier .....	38
7-2. Correction de bourrages de papier .....	38
<b>8. Nettoyage .....</b>	<b>39</b>
8-1. Nettoyage de la tête d'impression .....	39
8-2. Nettoyage du support de papier .....	39
<b>APPENDICE .....</b>	<b>80</b>

*L'appendice n'est pas traduit.*

Pour obtenir la dernière version de ce manuel, consultez l'adresse URL suivante:  
[http://www.star-micronics.co.jp/service/sp\\_sup\\_e.htm](http://www.star-micronics.co.jp/service/sp_sup_e.htm).

# 1. Identification des pièces et nomenclature

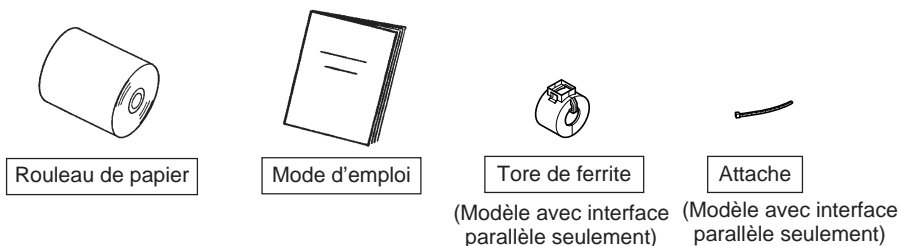
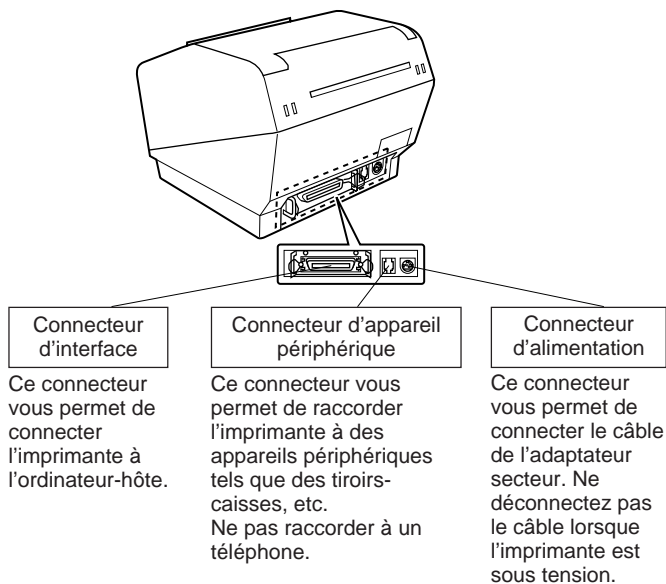
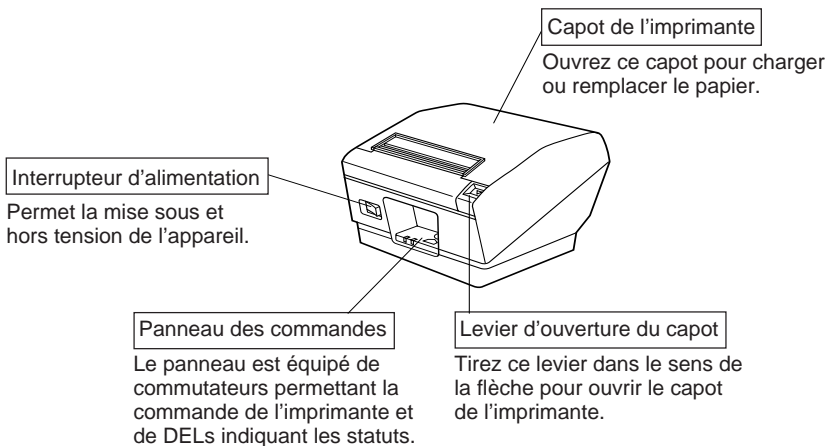



## *Emplacement de l'imprimante*

Avant de déballer l'imprimante, déterminez l'emplacement où vous souhaitez l'installer. Veuillez observer les points ci-dessous lors de votre choix.

- ✓ Choisissez une surface stable et de niveau sur laquelle l'imprimante ne sera exposée à aucune vibration.
- ✓ Assurez-vous que l'emplacement dispose d'une prise secteur proche et d'accès aisé.
- ✓ Assurez-vous que la distance entre l'imprimante et l'ordinateur-hôte vous permet de les raccorder aisément.
- ✓ Assurez-vous que l'imprimante n'est pas exposée directement aux rayons du soleil.
- ✓ Tenez l'imprimante à l'écart des sources de chaleur importante, telles que les appareils de chauffage, etc.
- ✓ Assurez-vous que le lieu où vous souhaitez installer l'imprimante est propre, sec et n'est pas poussiéreux.
- ✓ Assurez-vous que la prise secteur à laquelle vous raccordez l'imprimante délivre une tension stable. Évitez de raccorder l'imprimante à la prise secteur d'un circuit alimentant de gros consommateurs de courant, tels qu'un photocopieur, réfrigérateur, etc.
- ✓ Assurez-vous que le lieu où vous installez l'imprimante n'est pas excessivement humide.

## 2. Consommables et adaptateur secteur

Il convient d'utiliser exclusivement les types de papier figurant dans le tableau ci-dessous. Veuillez également à utiliser l'adaptateur secteur qui figure dans le tableau. L'utilisation d'un type de papier et d'adaptateur ne figurant pas dans le tableau risque d'endommager l'imprimante, de causer un incendie ou une décharge électrique.

### (1) Rouleau de papier, caractéristiques

Papier thermique

Épaisseur: 65~150  $\mu\text{m}$

Largeur: 111,5 $\pm$ 0,5 mm

Diamètre extérieur du rouleau:  $\phi$ 100 mm or less

Largeur du rouleau de papier: 112 $^{+0,3}_{-1}$  mm

Diamètre extérieur/intérieur du support de rouleau

Épaisseur du papier	Extérieur du support de rouleau	Intérieur du support de rouleau
65~75 $\mu\text{m}$	$\phi$ 18 $\pm$ 1 mm	$\phi$ 12 $\pm$ 1 mm
65~75 $\mu\text{m}$	$\phi$ 32 $\pm$ 1 mm	$\phi$ 25,4 mm
75~150 $\mu\text{m}$	$\phi$ 32 $\pm$ 1 mm	$\phi$ 25,4 mm

Surface imprimée: Bord extérieur du rouleau

Extrémité arrière: Ne pas utiliser de colle pour immobiliser le rouleau de papier ou son noyau.

Ne pas plier l'extrémité arrière du papier.

### (2) Papier conseillé

Mitsubishi paper mills limited

P220AG (papier de type normal), 65  $\mu\text{m}$  (épaisseur)

HP220A (papier à stabilité d'image élevée), 65  $\mu\text{m}$  (épaisseur)

HP220AB-1 (papier à stabilité d'image élevée), 75  $\mu\text{m}$  (épaisseur)

P220AB (papier de type normal, ticket), 85  $\mu\text{m}$  (épaisseur)

P220AC-1 (papier de type normal, ticket), 95  $\mu\text{m}$  (épaisseur)

P220AC (papier de type normal, ticket), 105  $\mu\text{m}$  (épaisseur)

P220AD (papier de type normal, ticket), 130  $\mu\text{m}$  (épaisseur)

P220AE-1 (papier de type normal, ticket), 150  $\mu\text{m}$  (épaisseur)

Oji paper Co., Ltd.

PD150R (papier de type normal), 75  $\mu\text{m}$  (épaisseur)

PD160R (papier à stabilité d'image élevée), 65/75  $\mu\text{m}$  (épaisseur)

Nippon paper industries

TF50KS-E2C (papier de type normal), 65  $\mu\text{m}$  (épaisseur)

Suivant le type et l'épaisseur du papier, il peut être nécessaire de changer le réglage de clarté d'impression. Pour changer le réglage de la clarté d'impression, utilisez la commande de réglage de clarté d'impression <ESC><RS>'d'n. Reportez-vous au manuel de programmation séparé pour les détails.

(3) Adaptateur secteur (option)

Nom du modèle: PS60-24 A

Entrée: CA100 à 240 V, 50/60 Hz

Sortie: CC24±5%, 2,0 A (charge de 10 sec à 5,0 A max.)

---

**Attention!**

*Pour obtenir des informations concernant le papier recommandé, consultez l'adresse URL suivante : <http://www.star-micronics.co.jp/>.*

---

## 3. Câbles de connexion et adaptateur secteur

### 3-1. Câble d'interface

#### 3-1-1. Installation du tore de ferrite (modèle avec interface parallèle seulement)

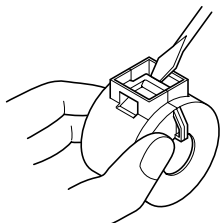

- (1) Modèle avec interface parallèle seulement: fixez la grande gaine en ferrite sur le câble comme illustré.

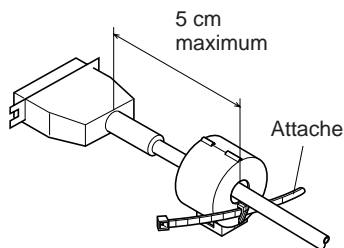
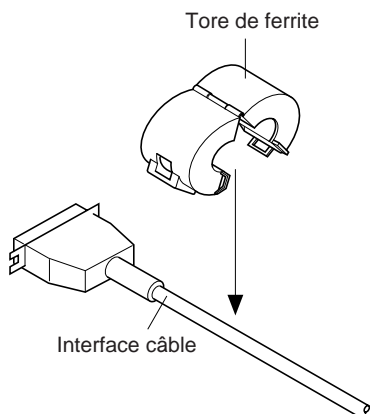

- (2) Passez l'attache dans le tore de ferrite.

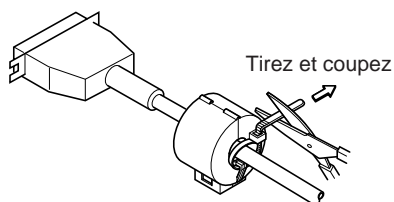

- (3) Passez l'attache autour du tore de ferrite et serrez-la. Coupez l'extrémité de l'attache à l'aide de ciseaux.

## 3-1-2. Connexion du câble d'interface

**Remarque:** Avant de connecter ou déconnecter le câble d'interface, veillez à ce que l'imprimante et tous les appareils qui y sont connectés soient hors tension. Veillez également à débrancher le câble d'alimentation de la prise secteur.

- (1) Connectez le câble d'interface à la borne figurant sur le panneau arrière de l'imprimante.
- (2) Dans le cas d'une interface série, resserrez les vis du connecteur. Dans le cas d'une interface parallèle, fixez le connecteur avec les fermoirs.

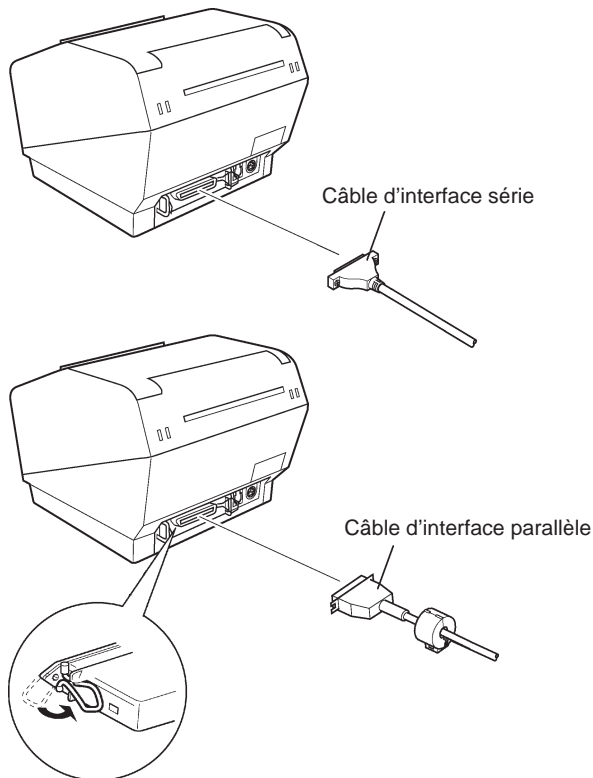

## 3-2. Raccordement d'un appareil périphérique

Vous pouvez raccorder un appareil périphérique à l'imprimante à l'aide d'une fiche modulaire. Nous expliquons ci-dessous comment installer le tore de ferrite et faire le raccordement proprement dit. Pour les détails sur le type de fiche modulaire à utiliser, reportez-vous à la page 80. Notez que le fil ou la fiche modulaires ne sont pas fournis avec l'imprimante. Vous devrez donc vous les procurer.

### *Attention!*

Assurez-vous que l'imprimante est hors tension, qu'elle est débranchée de la prise secteur et que l'ordinateur est hors tension avant d'effectuer les connexions.

- (1) Connectez le câble de pilote de périphérique à la borne figurant sur le panneau arrière de l'imprimante.

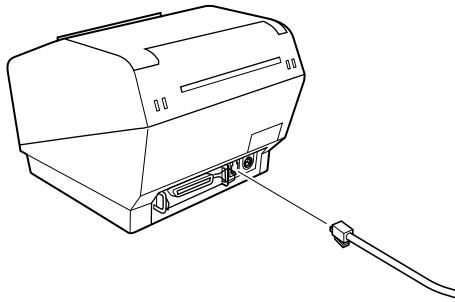

### 3-3. Connexion de l'adaptateur secteur optionnel

**Remarque:** Avant de connecter ou déconnecter l'adaptateur secteur, veillez à ce que l'imprimante et tous les appareils qui y sont connectés soient hors tension. Veillez également à débrancher le câble d'alimentation de la prise secteur.

(1) Connectez l'adaptateur secteur au câble d'alimentation.

**Remarque:** Utilisez exclusivement l'adaptateur secteur et le câble d'alimentation destinés à l'imprimante.

(2) Connectez l'adaptateur secteur à la borne de l'imprimante.

(3) Branchez la prise du câble d'alimentation à la prise secteur.

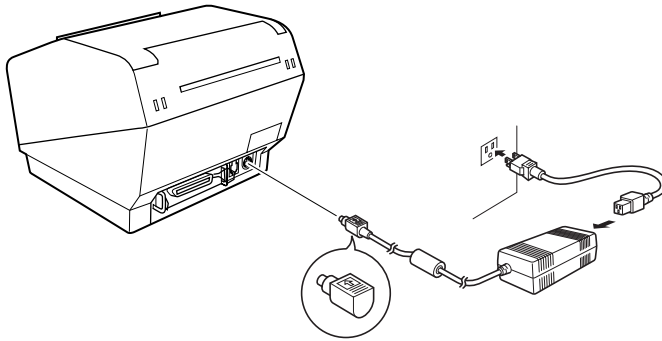

### 3-4. Mise sous tension de l'imprimante

Assurez-vous d'avoir bien connecté l'adaptateur secteur comme décrit à la section 3-3.

(1) Placez l'interrupteur d'alimentation, situé à l'avant de l'imprimante, sur la position sous tension.

La DEL POWER s'allume au panneau des commandes.

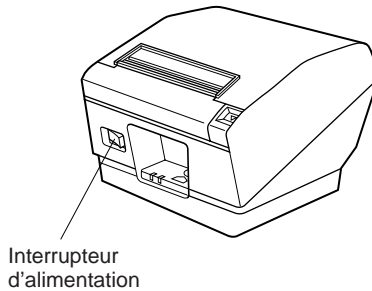

---

#### **Attention!**

*Nous vous recommandons de débrancher l'imprimante du secteur lorsque vous ne comptez pas l'utiliser pendant une période prolongée. Par ailleurs, veillez lors de l'installation à ce que la prise secteur alimentant l'imprimante soit proche et d'accès facile.*

---



## 4. Panneau de commande et autres fonctions

### 4-1. Panneau de commande

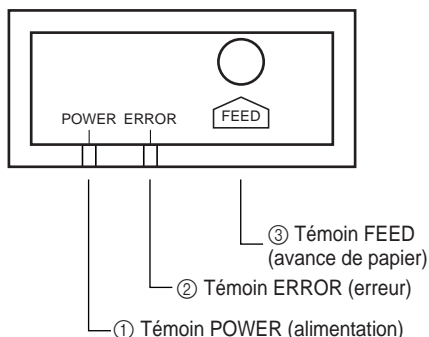

- ① Témoin POWER (DEL verte)  
S'allume quand l'appareil est sous tension.
- ② Témoin ERROR (DEL rouge)  
Indique des erreurs variées en combinaison avec le témoin POWER.
- ③ Témoin FEED  
Appuyez sur la touche FEED pour faire avancer le papier.

### 4-2. Erreurs

#### 1) Erreur récupérable automatiquement

Description de l'erreur	Témoin POWER	Témoin ERROR	Conditions de récupération
Détection de température élevée de la tête	Clignote à 0,5 seconde d'intervalle	Hors tension	Récupération automatique après refroidissement de la tête.
Erreur d'ouverture du capot de l'imprimante	Sous tension	Sous tension	Récupération automatique après fermeture du capot de l'imprimante.

#### 2) Erreur récupérable

Description de l'erreur	Témoin POWER	Témoin ERROR	Conditions de récupération
Erreur de découpe du papier	Hors tension	Clignote à 0,125 seconde d'intervalle	Récupération si l'unité de découpage revient dans sa position d'origine après la mise hors tension et sous tension.

#### Remarque

- 1) Si l'unité de découpage ne revient pas dans sa position d'origine ou n'effectue pas le mouvement initial, la récupération est impossible.
- 2) Si le papier est coincé, mettez l'appareil hors tension, dégagez le bourrage de papier, puis mettez l'appareil sous tension.

### 3) Erreur non récupérable

Description de l'erreur	Témoin POWER	Témoin ERROR	Conditions de récupération
Erreur de mémoire vive	Hors tension	Sous tension	Ce n'est pas une erreur récupérable. Consultez votre revendeur pour des réparations.
Erreur d'EPROM	Clignote à 0,25 seconde d'intervalle	Clignote à 0,25 seconde d'intervalle	Ce n'est pas une erreur récupérable. Consultez votre revendeur pour des réparations.
Erreur de thermistor	Clignote à 0,5 seconde d'intervalle	Clignote à 0,5 seconde d'intervalle	
Erreur d'alimentation	Clignote à 1 seconde d'intervalle	Clignote à 1 seconde d'intervalle	Ce n'est pas une erreur récupérable. Consultez votre revendeur pour des réparations.

#### Remarque

- 1) Si une erreur non récupérable se produit, mettez immédiatement l'appareil hors tension.
- 2) Quand une erreur d'alimentation se produit, il est possible que le bloc d'alimentation soit en panne.  
Pour d'autres erreurs non récupérables, veuillez consulter votre revendeur pour des réparations.

### 4) Erreur de détection de papier

Description de l'erreur	Témoin POWER	Témoin ERROR	Conditions de récupération
Erreur de sortie de papier	Sous tension	Clignote à 0,5 seconde d'intervalle	Récupération automatique après chargement d'un nouveau rouleau de papier et fermeture du capot de l'imprimante.
Le rouleau de papier est presque terminé	Sous tension	Clignote à 0,2 seconde d'intervalle	Les indicateurs signalent la fin proche du rouleau, mais l'imprimante continue à imprimer.

## 4-3. Auto-impression

### (1) Essai d'impression

Mettez l'appareil sous tension tout en maintenant la touche FEED enfoncée. L'essai d'impression sera effectué en fonction du numéro de version, des réglages du commutateur DIP et de l'ordre des caractères. Si vous appuyez sur la touche FEED à la fin de l'essai d'impression, seuls les caractères seront imprimés à plusieurs reprises.

\*\*\* TSP800 Ver1.00

Interface : Parallel

DIP Switch 1

Sw 12345678

On \*\*\*\*\*

Off

1,2 = Emulation : Star Line

4 = Sensor Adjustment : Off

5 = INIT Reset : Enable

6 = BUSY : All

7 = ASB : Disable

Memory Switch

FEDCBA9876543210 HEX.

<0> 0000000000000000 0000

<1> 0000000000000000 0000

0123456789:;<=>?@ABCDEF  
 .-./0123456789:;<=>?@ABCDEF  
 -./0123456789:;<=>?@ABCDEF  
 .-./0123456789:;<=>?@ABCDEF  
 /0123456789:;<=>?@ABCDEF  
 0123456789:;<=>?@ABCDEF  
 123456789:;<=>?@ABCDEF  
 23456789:;<=>?@ABCDEF  
 3456789:;<=>?@ABCDEF  
 456789:;<=>?@ABCDEF  
 56789:;<=>?@ABCDEF

## (2) Mode de vidage hexadécimal

Ouvrez le capot de l'imprimante, puis mettez l'appareil sous tension tout en maintenant la touche FEED enfoncée. Quand le capot est fermé, "\*\*\* HEX DUMP PRINTING \*\*\*" est imprimé et l'imprimante entre en mode de vidage hexadécimal.

Chacun des signaux envoyés par l'ordinateur à l'imprimante sera imprimé dans le code hexadécimal.

Cette fonction vous permet de vérifier si un code de commande envoyé à l'imprimante par le programme utilisé est correct ou non. La ligne finale n'est pas imprimée si ses données sont inférieures à une ligne complète. Néanmoins, si vous appuyez sur la touche FEED, la ligne finale sera imprimée. Pour désactiver ce mode, il est nécessaire de mettre l'imprimante complètement hors tension.

\*\*\* HEX DUMP PRINTING \*\*\*

20	21	22	23	24	25	26	27	!"#\$%&'
28	29	2A	2B	2C	2D	2E	2F	()**,-./
30	31	32	33	34	35	36	37	01234567
38	39	3A	3B	3C	3D	3E	3F	89:;<=>?
40	41	42	43	44	45	46	47	@ABCDEFG
48	49	4A	4B	4C	4D	4E	4F	HIJKLMNO
50	51	52	53	54	55	56	57	PQRSTUVWXYZ

## 5. Chargement du rouleau de papier

Veillez à utiliser un rouleau de papier qui correspond aux spécifications de l'imprimante.

Poussez le levier d'ouverture du capot et ouvrez le capot de l'imprimante.

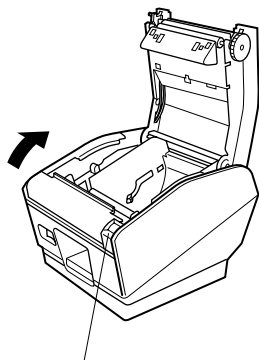

Levier d'ouverture du capot

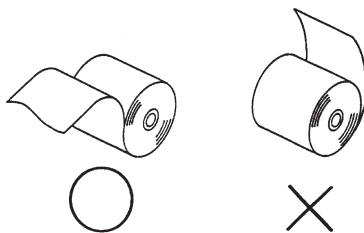

Mettez le rouleau de papier en place dans le creux tout en respectant son orientation, et tirez sur l'extrémité du papier.

**Remarque 1:** Quand vous utilisez un papier dont l'épaisseur rend nécessaire l'utilisation de la barre de tension ( $65 \mu\text{m} \leq \text{épaisseur du papier} < 100 \mu\text{m}$ ), veillez à ne pas faire passer le papier sous la barre de tension.

**Remarque 2:** Quand vous utilisez un papier dont l'épaisseur ne rend pas nécessaire l'utilisation de la barre de tension ( $100 \mu\text{m} \leq \text{épaisseur du papier} \leq 150 \mu\text{m}$ ), veillez enlever avant tout les deux vis à chaque extrémité de la barre de tension avec un tournevis, puis la barre de tension. Normalement, cette procédure (retrait de la barre de tension) devrait avoir été effectuée par votre revendeur.

Rouleau de papier

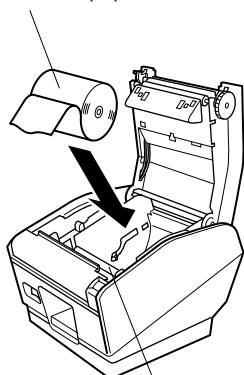

Barre de tension

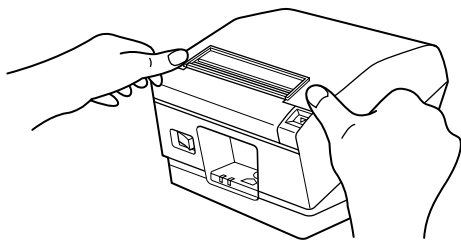

Poussez vers la bas les deux côtés du capot de l'imprimante pour le fermer.

**Remarque:** Assurez-vous que le capot de l'imprimante est bien fermé.

### **Attention!**

1. *Ne pas toucher la lame du coupe-ruban.*
  - Une lame se trouve dans la fente de sortie de papier. Il est fortement déconseillé de mettre sa main dans la fente de sortie de papier non seulement pendant l'impression mais aussi en toute autre circonstance, même quand l'impression n'est pas effectuée.
  - Le capot de l'imprimante peut être ouvert pour remplacer le papier. Néanmoins, la lame du coupe-ruban se trouvant à l'intérieur du capot de l'imprimante, veuillez faire attention à ne pas rapprocher votre figure ou vos mains trop près de la lame du coupe-ruban.
2. *Ne pas faire fonctionner le levier d'ouverture du capot tout en appuyant sur le capot de l'imprimante avec la main.*
3. *Ne pas tirer sur le papier pour le faire sortir quand le capot de l'imprimante est fermé.*
4. *L'élément de chauffage et le circuit imprimé de la tête d'impression thermique sont facilement endommagés. Ne pas les toucher avec des objets métalliques, du papier de verre, etc.*
5. *Pendant et immédiatement après l'impression, la zone autour de la tête d'impression thermique est très chaude. Ne pas la toucher car vous pourriez vous brûler.*
6. *La qualité d'impression peut être affectée si l'élément de chauffage de la tête d'impression thermique est souillé par un contact avec vos mains, Ne pas toucher l'élément de chauffage de la tête d'impression thermique.*
7. *Le circuit imprimé de la tête d'impression thermique peut être endommagé par l'électricité statique. Veuillez prendre des précautions.*
8. *La qualité d'impression et la durée de vie utile de la tête d'impression thermique ne peuvent pas être garanties si un papier quelconque différent de celui recommandé est utilisé. En particulier, le papier contenant les éléments suivants: NA+, K+, CI-, peut réduire de façon importante la durée de vie utile de la tête d'impression thermique. Veuillez prendre des précautions.*
9. *Ne pas faire fonctionner l'imprimante si de l'humidité provenant de la condensation, etc., est présente sur la surface avant de la tête.*

## 6. Réglage du capteur de fin de rouleau

Utilisez la procédure suivante pour régler le capteur de fin de rouleau conformément à la taille du rouleau de papier utilisé.

- ① Ouvrez le capot de l'imprimante.
- ② Déterminez le diamètre du rouleau de papier utilisé et identifiez le réglage requis dans le tableau ci-dessous.
- ③ Insérez la pointe d'un stylo bille ou un autre instrument pointu similaire dans le trou du curseur de réglage. Tout en appuyant sur le curseur de réglage, faites-le glisser vers le haut ou le bas jusqu'au réglage correspondant au rouleau de papier utilisé.

Assurez-vous que l'ergot indiqué par la flèche dans l'illustration se trouve à l'intérieur d'une des nervures.

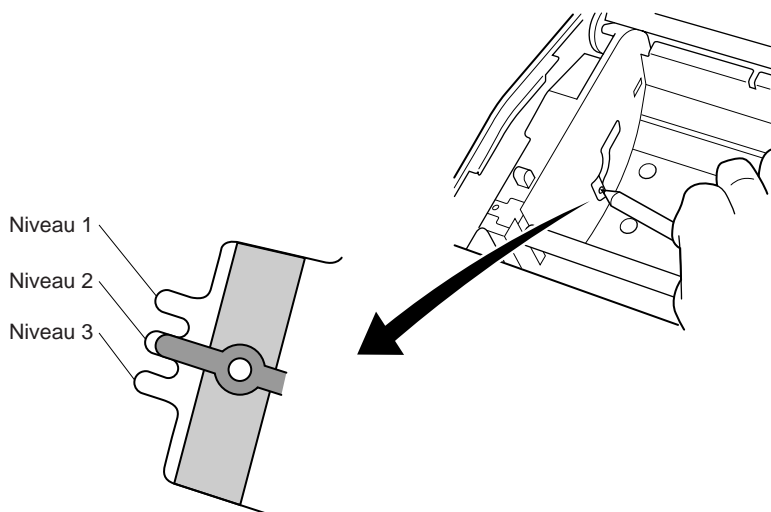

Valeur de réglage correspondant au papier utilisé.

Épaisseur du papier ( $\mu\text{m}$ )	Quand vous utilisez un rouleau de papier dont le diamètre intérieur du support est de (A): $\phi 12$ et le diamètre extérieur de (B): $\phi 18$					
	Diamètre détecté (C) (Env. mm)			Longueur de papier restante (Env. m)		
	Niveau 1	Niveau 2	Niveau 3	Niveau 1	Niveau 2	Niveau 3
65	$\phi 23$	$\phi 27$	$\phi 31$	2,5	4,9	7,7
75				2,1	4,2	6,7

Épaisseur du papier ( $\mu\text{m}$ )	Quand vous utilisez un rouleau de papier dont le diamètre intérieur du support est de (A): $\phi 25,4$ et le diamètre extérieur de (B): $\phi 32$					
	Diamètre détecté (C) (Env. mm)			Longueur de papier restante (Env. m)		
	Niveau 1	Niveau 2	Niveau 3	Niveau 1	Niveau 2	Niveau 3
65	$\phi 36$	$\phi 40$	$\phi 44$	2,8	6,4	10,4
75				2,4	5,5	9,0
85				2,1	4,9	7,9
95				1,9	4,4	7,1
105				1,7	4,0	6,4
130				1,4	3,2	5,2
150				1,2	2,8	4,5

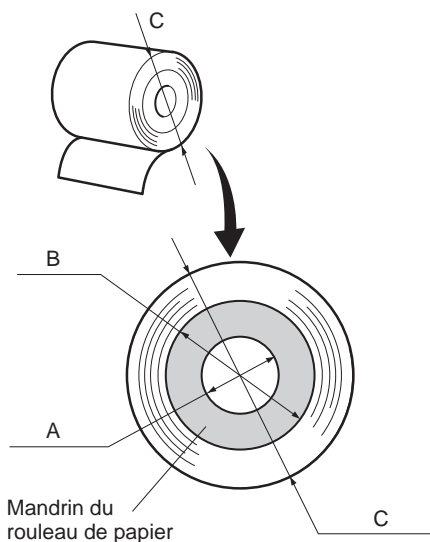

### Remarque

- 1) Le curseur de réglage est réglé sur le niveau 1 en usine.
- 2) La dimension C et la longueur de papier restante sont les valeurs calculées. Il est possible qu'il y ait quelques différences dans le mécanisme actuel.



## 7. Prévention et correction de bourrages de papier

### 7-1. Prévention des bourrages de papier

Il convient de ne jamais toucher le papier pendant son éjection et avant qu'il soit coupé. Appuyer ou tirer sur le papier pendant son éjection risque de provoquer un bourrage, des problèmes de coupure ou d'avance de ligne.

### 7-2. Correction de bourrages de papier

En cas de bourrage de papier, procédez comme suit afin d'y remédier :

- (1) Mettez l'appareil hors tension.
- (2) Tirez le levier tout à fait vers le bas afin d'ouvrir le capot de l'imprimante.
- (3) Retirez le papier bloqué.  
**Remarque:** Veillez à ne pas endommager l'imprimante lors du retrait du papier bloqué.  
Veillez particulièrement à ne pas toucher la tête d'impression thermique en raison de sa fragilité.
- (4) Veillez à insérer le rouleau de papier tout droit et refermez avec soin le capot de l'imprimante.  
**Remarque 1:** Le papier doit être placé bien droit. Si vous refermez le capot de l'imprimante alors que le papier est de travers (voir illustration), un bourrage peut se produire.  
  
**Remarque 2:** Verrouillez le capot de l'imprimante en appuyant sur les côtés. Ne pas essayer de refermer le capot en appuyant sur son centre. Le capot pourrait ne pas se verrouiller correctement.
- (5) Mettez l'imprimante sous tension. Assurez-vous que la DEL ERROR n'est pas allumée.  
**Remarque:** Tant que la DEL ERROR est allumée, l'imprimante n'accepte aucune commande. Il faut donc veiller à ce que le capot de l'imprimante soit verrouillé.

## 8. Nettoyage

Les caractères imprimés pourraient devenir partiellement illisibles en raison de l'accumulation de la poussière de papier et de crasse. Afin de prévenir ce genre de problème, il convient de nettoyer régulièrement la poussière qui s'accumule sur le support de papier, les passages du papier et la surface de la tête d'impression. Il est recommandé d'effectuer un tel nettoyage une fois tous les six mois ou après l'impression d'un million de lignes.

### 8-1. Nettoyage de la tête d'impression

Nettoyez la poussière noirâtre accumulée sur la surface de la tête d'impression à l'alcool isopropylique.

**Remarque:** La tête d'impression thermique est fragile, il convient donc de procéder avec précaution. Prenez soin de ne pas la griffer.

### 8-2. Nettoyage du support de papier

Nettoyez la poussière de papier accumulée sur le support de papier et sur les passages du papier à l'aide d'un chiffon doux.

# INHALTSVERZEICHNIS

<b>1. Beschreibung und Bezeichnung der Geräteteile .....</b>	<b>41</b>
<b>2. Verbrauchsteile und Netzteil .....</b>	<b>43</b>
<b>3. Anschlußkabel und Netzteil .....</b>	<b>45</b>
3-1. Schnittstellenkabel .....	45
3-2. Anschluß an ein Peripheriegerät .....	47
3-3. Anschließen des optionalen Netzteils .....	48
3-4. Einschalten .....	49
<b>4. Bedienfeld und andere Funktionen .....</b>	<b>50</b>
4-1. Bedienfeld .....	50
4-2. Fehler .....	50
4-3. Selbstdruck .....	52
<b>5. Einlegen der Papierrolle .....</b>	<b>54</b>
<b>6. Einstellung des Endanäherungs-Sensors .....</b>	<b>56</b>
<b>7. Verhindern und Beheben von Papierstau .....</b>	<b>58</b>
7-1. Verhindern von Papierstau .....	58
7-2. Beheben von Papierstau .....	58
<b>8. Regelmäßige Reinigung .....</b>	<b>59</b>
8-1. Reinigen des Thermalkopfes .....	59
8-2. Reinigen des Papierhalters .....	59
<b>ANHANG .....</b>	<b>80</b>

*Der Anhand dieser Bedienungsanleitung ist nur in englischer Sprache.*

Bitte wenden Sie sich an die folgende Internet-Address:

[http://www.star-micronics.co.jp/service/sp\\_sup\\_e.htm](http://www.star-micronics.co.jp/service/sp_sup_e.htm),

wenn Sie die neueste Revision dieses Handbuches lesen möchten.

# 1. Beschreibung und Bezeichnung der Geräteteile

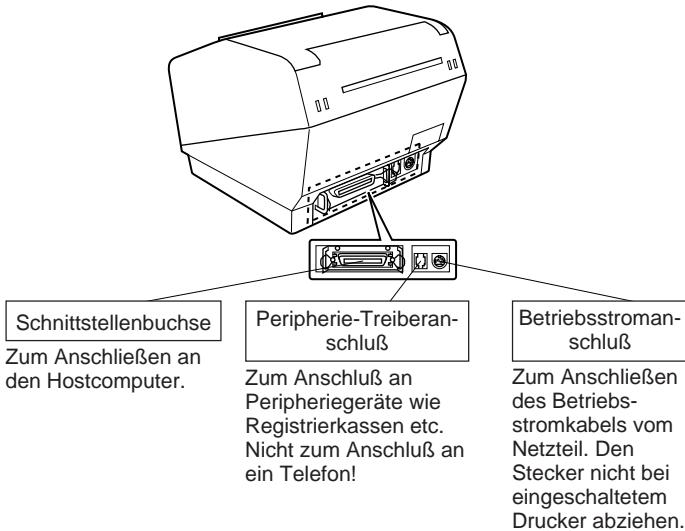
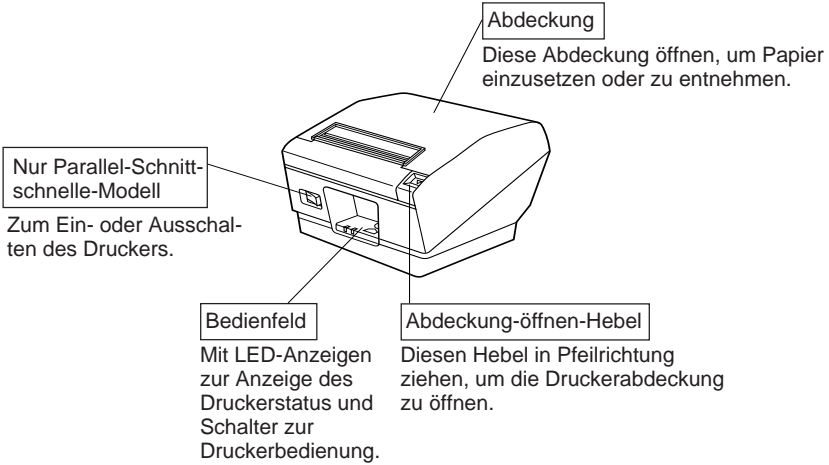

Rollenpapier



Bedienungsanleitung



Ferritkern



Befestigungsband

(Nur beim Parallel-Schnittschnelle-Modell) (Nur beim Parallel-Schnittschnelle-Modell)

## *Wahl eines Aufstellungsorts für den Drucker*

Bevor Sie den Drucker auspacken, sollten Sie einige Minuten damit verbringen, einen geeigneten Aufstellungsort auszusuchen. Denken Sie dabei an die folgenden Punkte:

- ✓ Den Drucker auf einem flachen, aber festen Untergrund aufstellen, wo keine Vibrationen vorhanden sind.
- ✓ Die verwendete Steckdose soll in der Nähe und frei zugänglich sein.
- ✓ Sicherstellen, daß der Drucker nahe genug am Computer ist, um die Geräte mit dem Druckerkabel verbinden zu können.
- ✓ Sicherstellen, daß der Drucker vor direktem Sonnenlicht geschützt ist.
- ✓ Sicherstellen, daß der Drucker ausreichend weit von Heizkörpern entfernt steht.
- ✓ Dafür sorgen, daß die Umgebung des Druckers sauber, trocken und staubfrei ist.
- ✓ Sicherstellen, daß der Drucker an eine einwandfreie Stromzufuhr angeschlossen ist. Er sollte nicht an Steckdosen angeschlossen werden, an denen bereits Geräte mit möglichen Netzstörungen wie Kopierer, Kühlschränke u.a. angeschlossen sind.
- ✓ Den Drucker nicht an Orten mit hoher Luftfeuchtigkeit aufstellen.

## 2. Verbrauchsteile und Netzteil

Wenn die Verbrauchsteile verbraucht sind, besorgen Sie Ersatz entsprechend der unten gezeigten Tabelle.

Verwendung von Verbrauchsteilen oder Netzteilen, die nicht den unten aufgeführten Beschreibungen entsprechend, kann zu Schäden am Drucker, Bränden oder elektrischen Schlägen führen.

### (1) Rollenpapierbeschreibung

Thermopapier

Dicke: 65~150  $\mu\text{m}$

Breite: 111,5 $\pm$ 0,5 mm

Rollen-Außendurchmesser:  $\phi$ 100 mm or less

Breite der Aufnehmerpapierrolle: 112 $^{+0,3}_{-1}$  mm

Kern Außen/Innen-Durchmesser

Papierdicke	Kern außen	Kern innen
65~75 $\mu\text{m}$	$\phi$ 18 $\pm$ 1 mm	$\phi$ 12 $\pm$ 1 mm
65~75 $\mu\text{m}$	$\phi$ 32 $\pm$ 1 mm	$\phi$ 25,4 mm
75~150 $\mu\text{m}$	$\phi$ 32 $\pm$ 1 mm	$\phi$ 25,4 mm

Druckfläche: Äußere Papierkante

Behandlung der Papierendkante: Nicht Paste oder Kleber zum Befestigen von Papierrolle oder Kern verwenden.

Nicht die Papierendkante falten.

### (2) Empfohlenes Papier

Mitsubishi Paper Mills Ltd.

P220AG (Normalpapier), 65  $\mu\text{m}$  (Dicke)

HP220A (Papier für hochstabile Bilder), 65  $\mu\text{m}$  (Dicke)

HP220AB-1 (Papier für hochstabile Bilder), 75  $\mu\text{m}$  (Dicke)

P220AB (Normalpapier, Kartenticket), 85  $\mu\text{m}$  (Dicke)

P220AC-1 (Normalpapier, Kartenticket), 95  $\mu\text{m}$  (Dicke)

P220AC (Normalpapier, Kartenticket), 105  $\mu\text{m}$  (Dicke)

P220AD (Normalpapier, Kartenticket), 130  $\mu\text{m}$  (Dicke)

P220AE-1 (Normalpapier, Kartenticket), 150  $\mu\text{m}$  (Dicke)

Oji Paper Co., Ltd.

PD150R (Normalpapier), 75  $\mu\text{m}$  (Dicke)

PD160R (Papier für hochstabile Bilder), 65/75  $\mu\text{m}$  (Dicke)

Nippon Paper Industries

TF50KS-E2C (Normalpapier), 65  $\mu\text{m}$  (Dicke)

Je nach Typ und Stärke des Papiers kann es erforderlich sein, die Einstellungen für die Druckintensität zu ändern. Zum Ändern der Intensitätseinstellung den Druckintensität-Befehle <ESC><RS>'d'n verwenden. Einzelheiten siehe Programmieranleitung.

(3) Netzteil (Option)

Modelbezeichnung: PS60-24 A

Eingang: 100 bis 240 V WS, 50/60 Hz

Ausgang: 24 V GS±5%, max. 2,0 A (max. 10 s bei 5,0 A Last)

---

**Wichtig!**

*Empfehlungen zu den zu verwendenden Papiersorten sind im Internet bei der folgenden URL erhältlich: <http://www.star-micronics.co.jp/>*

---

## 3. Anschlußkabel und Netzteil

### 3-1. Schnittstellenkabel

#### 3-1-1. Anbringen des Ferritkerns (Nur beim Parallel-Schnittschnelle-Modell)

- (1) Nur beim Parallel-Schnittschnelle-Modell, Befestigen Sie den großen Ferritkern am Kabel, wie das in der folgenden Abbildung gezeigt wird.

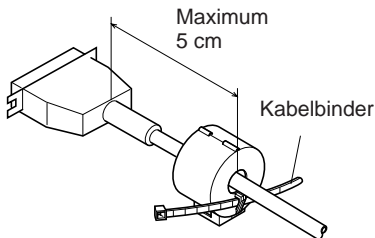
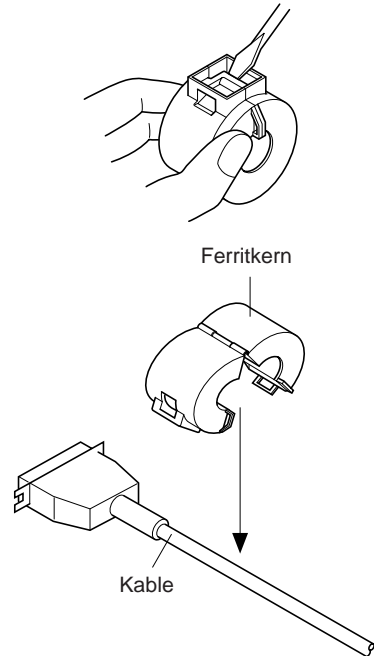

- (2) Führen Sie den Kabelbinder durch den Ferritkern.

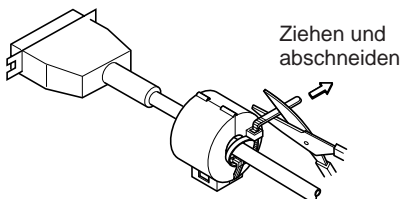

- (3) Führen Sie den Kabelbinder um das Kabel und sperren Sie ihn. Schneiden Sie überschüssiges Band mit einer Schere ab.



### 3-1-2. Anschließen des Schnittstellenkabels

**Hinweis:** Vor dem Anschließen/Abtrennen des Schnittstellenkabels stellen Sie sicher, daß der Drucker und alle angeschlossenen Geräte ausgeschaltet sind. Außerdem sollte der Netzstecker abgezogen sein.

- (1) Schließen Sie das Schnittstellenkabel an die Buchse an der Rückseite des Druckers an.
- (2) Bei einer seriellen Schnittstelle ziehen Sie die Steckerschrauben fest. Bei einer parallelen Schnittstelle befestigen Sie die Steckerklammern.

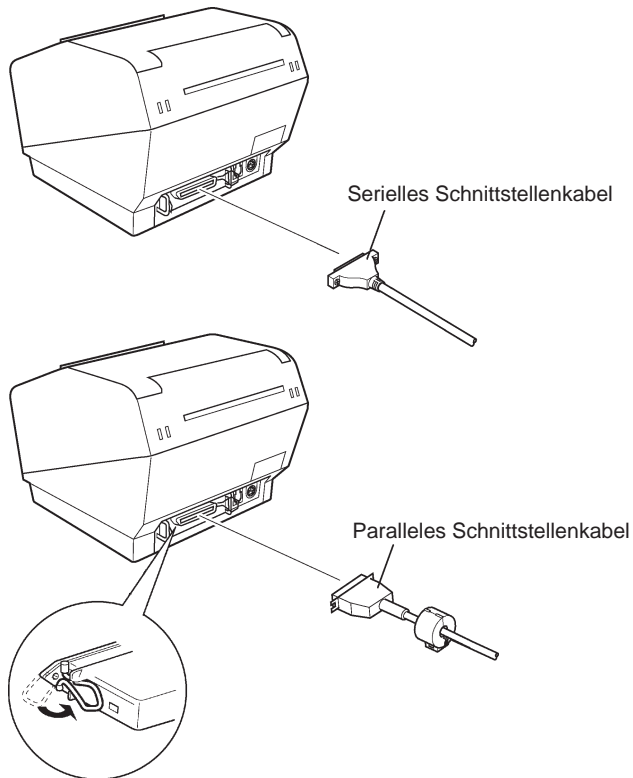

DEUTSCH

## 3-2. Anschluß an ein Peripheriegerät

Es kann ein Peripheriegerät an den Drucker mit einem Modularstecker angeschlossen werden. Im folgenden wird beschrieben, wie der Ferritkern angebracht und die Verbindung hergestellt wird. Siehe "Modularstecker" auf Seite 80 für den Typ von Modularstecker, der dazu erforderlich ist. Beachten Sie, daß der Drucker nicht mit einem Modularstecker oder Kabel ausgestattet ist. Diese Teile müssen vom Anwender besorgt werden.

### **Wichtig!**

Vor dem Anschließen der Kabel sicherstellen, daß der Drucker ausgeschaltet und vom Netz getrennt ist.

- (1) Schließen Sie das Peripheriegeräte­kabel an die Buchse an der Rückseite des Druckers an.

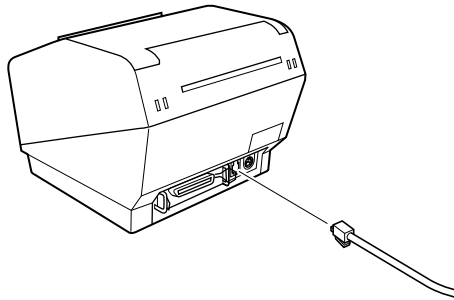

### 3-3. Anschließen des optionalen Netzteils

**Hinweis:** Vor dem Anschließen/Abtrennen des Netzteils stellen Sie sicher, daß der Drucker und alle angeschlossenen Gerät ausgeschaltet sind. Außerdem sollte der Netzstecker abgezogen sein.

(1) Schließen Sie das Netzteil an das Netzkabel an.

**Hinweis:** Verwenden Sie nur das vorgesehene Netzteil und Netzkabel.

(2) Das Netzteil am Stecker des Druckers anschließen.

(3) Stecken Sie den Netzstecker des Netzteils in eine Steckdose ein.

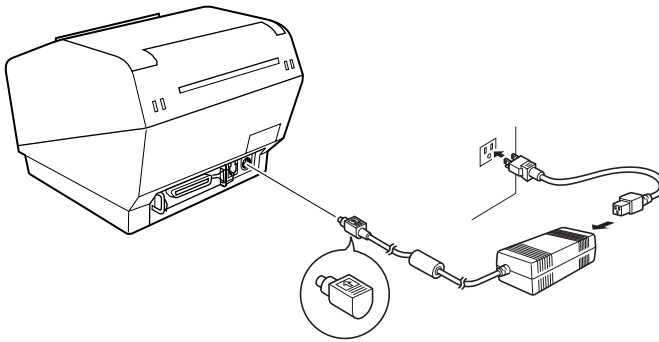

### 3-4. Einschalten

Stellen Sie sicher, daß das Netzteil angeschlossen ist, wie in 3-3 beschrieben.

- (1) Den Netzschalter vorne am Gerät auf Ein (ON) stellen. Das POWER-Lämpchen am Bedienfeld leuchtet auf.

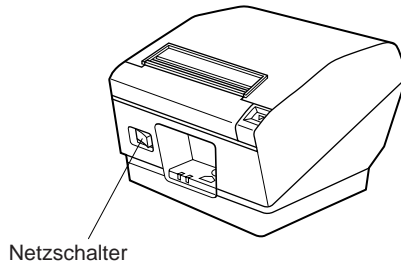

---

#### **Wichtig!**

*Wir empfehlen, den Netzstecker aus der Steckdose zu ziehen, wenn der Drucker längere Zeit lang nicht benutzt werden soll. Der Drucker sollte vorzugsweise an einem Platz aufgestellt werden, der leichten Zugang zur Netzsteckdose gewährt.*

---

# 4. Bedienfeld und andere Funktionen

## 4-1. Bedienfeld

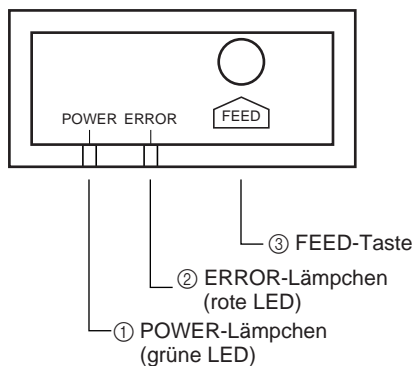

- ① POWER-Lämpchen (grüne LED)  
Leuchtet in eingeschaltetem Zustand
- ② ERROR-Lämpchen (rote LED)  
Zeigt in Kombination mit dem POWER-Lämpchen verschiedene Fehlerzustände an
- ③ FEED-Taste  
Die FEED-Taste drücken, um das Rollenpapier vorzutransportieren.

DEUTSCH

## 4-2. Fehler

### 1) Automatisch behebbare Fehler

Fehlerbeschreibung	POWER-Lämpchen	ERROR-Lämpchen	Behebungsbedingungen
Erkennung hoher Kopftemperatur	Blinkt in Abständen von 0,5 s	Aus	Automatische Behebung nach Abkühlen des Druckkopfes.
Abdeckung-Offen-Fehler	Ein	Ein	Automatische Behebung nach Schließen der Druckerabdeckung.

### 2) Behebbarer Fehler

Fehlerbeschreibung	POWER-Lämpchen	ERROR-Lämpchen	Behebungsbedingungen
Papierschnitt-Fehler	Aus	Blinkt im Abstand von 0,125 s	Behoben, wenn das Schneidwerk nach dem Ein- und Ausschalten in Grundstellung zurückkehrt.

### Hinweis

- 1) Wenn das Schneidwerk nicht in Grundstellung zurückkehrt oder nicht die Anfangsbewegung ausführt, ist Behebung nicht möglich.
- 2) Wenn Papierstau vorliegt, ausschalten, den Papierstau beheben, und dann wieder einschalten.

### 3) Nicht behebbare Fehler

Fehlerbeschreibung	POWER-Lämpchen	ERROR-Lämpchen	Behebungsbedingungen
Papierschnitt-Fehler	Aus	Ein	Dies ist ein nicht behebbarer Fehler. Der Kundendienst muß bezüglich Reparatur kontaktiert werden.
EEPROM-Fehler	Blinkt im Abstand von 0,25 s	Blinkt im Abstand von 0,25 s	Dies ist ein nicht behebbarer Fehler. Der Kundendienst muß bezüglich Reparatur kontaktiert werden.
Thermistor-Fehler	Blinkt im Abstand von 0,5 s	Blinkt im Abstand von 0,5 s	
Stromversorgung-Fehler	Blinkt im Abstand von 1 s	Blinkt im Abstand von 1 s	Dies ist ein nicht behebbarer Fehler. Der Kundendienst muß bezüglich Reparatur kontaktiert werden.

#### Hinweis

- 1) Wenn ein nicht behebbarer Fehler auftritt, das Gerät sofort ausschalten.
- 2) Wenn ein Stromversorgung-Fehler auftritt, besteht die Möglichkeit, daß die Netzversorgung nicht richtig ist.  
Bei anderen nicht behebbaren Fehlern muß der Kundendienst bezüglich Reparatur kontaktiert werden.

### 4) Papiererkennung-Fehler

Fehlerbeschreibung	POWER-Lämpchen	ERROR-Lämpchen	Behebungsbedingungen
Papierschnitt-Fehler	Aus	Blinkt im Abstand von 0,5 s	Automatische Behebung durch Einlegen einer neuen Papierrolle und Schließen der Druckerabdeckung.
Papierrollenende fast erreicht	Ein	Blinkt im Abstand von 0,2 s	Die Anzeigen zeigen, daß das Ende der Papierrolle sich nähert, aber der Drucker druckt weiter.

## 4-3. Selbstdruck

### (1) Testdruck

Das Gerät einschalten, während die FEED-Taste gedrückt gehalten wird. Der Testdruck wird entsprechend der Ver. Nr., den DIP-Schalter-Einstellungen und der Zeichenfolge ausgeführt. Wenn die FEED-Taste beim Ende des Testdrucks gedrückt wird, werden nur die Zeichen wiederholt ausgedruckt.

\*\*\* TSP800 Ver1.00

Interface : Parallel

DIP Switch 1

Sw 12345678  
On \*\*\*\*\*  
Off

1,2 = Emulation : Star Line  
4 = Sensor Adjustment : Off  
5 = INIT Reset : Enable  
6 = BUSY : All  
7 = ASB : Disable

Memory Switch

FEDCBA9876543210 HEX.  
<0> 0000000000000000 0000  
<1> 0000000000000000 0000

0123456789::<=>?@ABCDEF  
./0123456789::<=>?@ABCDEF  
-./0123456789::<=>?@ABCDEF  
./0123456789::<=>?@ABCDEF  
/0123456789::<=>?@ABCDEF  
0123456789::<=>?@ABCDEF  
123456789::<=>?@ABCDEF  
23456789::<=>?@ABCDEF  
3456789::<=>?@ABCDEF  
456789::<=>?@ABCDEF  
56789::<=>?@ABCDEF

DEUTSCH

## (2) Sedezimaler Datenausdruck

Die Druckerabdeckung öffnen, und dann einschalten, während die FEED-Taste gedrückt gehalten wird. Wenn die Abdeckung geschlossen wird, wird “\*\*\*HEX DUMP PRINTING\*\*\*” ausgedruckt, und der Drucker schaltet auf die Betriebsart sedezipalmer Datenausdruck um.

Jedes der vom Computer zum Drucker gesandten Signale wird nun als sedezipalmer Code ausgedruckt.

Diese Funktion erlaubt es, zu prüfen, ob ein von der Sowa zum Drucker gesandter Steuercode korrekt ist oder nicht. Die letzte Zeile wird nicht ausgedruckt, wenn Daten für weniger als eine ganze Zeile vorhanden sind.

Wenn die FEED-Taste gedrückt wird, wird aber auch die letzte Zeile ausgedruckt. Zum Ausschalten dieser Betriebsart ist es erforderlich, den Drucker vollständig auszuschalten.

\*\*\* HEX DUMP PRINTING \*\*\*

20 21 22 23 24 25 26 27	!"#\$%&'
28 29 2A 2B 2C 2D 2E 2F	()*+,-./
30 31 32 33 34 35 36 37	01234567
38 39 3A 3B 3C 3D 3E 3F	89:;<=>?
40 41 42 43 44 45 46 47	@ABCDEFG
48 49 4A 4B 4C 4D 4E 4F	HIJKLMNO
50 51 52 53 54 55 56 57	PQRSTUVWXYZ



## 5. Einlegen der Papierrolle

Immer Rollenpapier verwenden, das zu den technischen Daten des Druckers paßt.

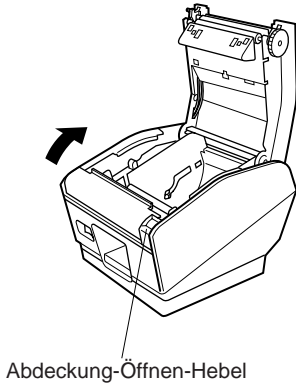

Den Abdeckung-Öffnen-Hebel drücken, und die Druckerabdeckung öffnen.

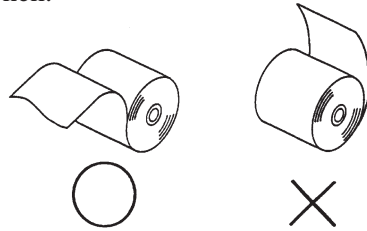

Unter Beachtung der richtigen Einsetzurichtung der Rolle die Papierrolle in die Vertiefung legen und die Vorderkante des Papiers nach vorne ziehen.

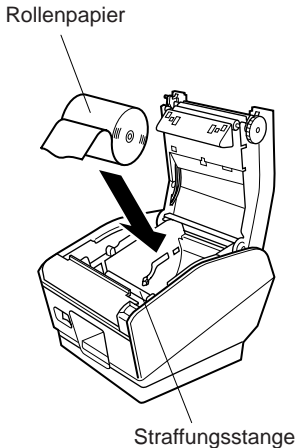

**Hinweis 1:** Wenn Papier mit einer Dicke verwendet wird, die die Straffziehstange erforderlich macht ( $65 \mu\text{m} \leq \text{Papierdicke} < 100 \mu\text{m}$ ), müssen die beiden Schrauben an beiden Seiten der Straffziehstange mit einem Schraubenzieher entfernt werden, und die Straffziehstangeneinheit vorher entfernt werden.

**Hinweis 2:** Wenn Papier mit einer Stärke verwendet wird, die die Verwendung nicht erforderlich macht ( $100 \mu\text{m} \leq \text{Papierdicke} \leq 150 \mu\text{m}$ ), entfernen Sie die beiden Schrauben an beiden Seiten der Spannstange mit einem Schraubenzieher und entfernen Sie die Spannstange vorher. Normalerweise sollte diese Arbeit (Entfernen des Spannstiftes) bereits vom Händler ausgeführt worden sein.

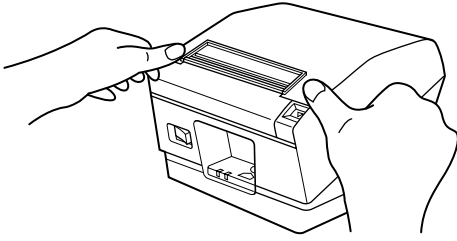

Beide Seiten der Druckerabdeckung zum Schließen nach unten drücken.

**Hinweis:** Sicherstellen, daß die Druckerabdeckung fest geschlossen ist.

---

### **Wichtig!**

1. *Nicht die Schneidwerkklinge berühren.*
  - *Im Papierauslaßschlitz befindet sich ein Schneidwerk. Niemals die Hände in den Auslaßschlitz stecken, nicht nur während des Druckbetriebs sondern auch wenn der Drucker nicht arbeitet.*
  - *Die Druckerabdeckung kann geöffnet werden, wenn das Papier ausgetauscht wird. Da das Schneidwerk im Inneren der Druckerabdeckung ist, darauf achten, nicht das Gesicht oder die Hände zu nahe an das Schneidwerkmesser zu bringen.*
2. *Nicht den Lösehebel der Abdeckung betätigen, während mit der Hand auf die Druckerabdeckung gedrückt wird.*
3. *Nicht das Papier bei geschlossener Druckerabdeckung herausziehen.*
4. *Das Heizelement und der Treiber-Chip des Thermalkopfes werden leicht beschädigt. Diese Teile nicht mit Metallgegenständen, Sandpapier usw. berühren.*
5. *Während des Druckens und kurz nach dem Drucken kann der Bereich um den Thermalkopf sehr heiß werden. Nicht das Heizelement mit der Hand berühren.*
6. *Die Druckqualität kann nachlassen, wenn das Thermalkopf-Heizelement durch Berührung mit der Hand verschmutzt wird. Nicht das Thermalkopf-Heizelement berühren.*
7. *Es besteht die Gefahr von Schäden am Treiber-Chip durch statische Elektrizität. Bitte sehr vorsichtig arbeiten.*
8. *Die Druckqualität und die Lebensdauer des Thermalkopfes kann nicht garantiert werden, wenn anderes als Papier der vorgeschriebenen Sorte verwendet wird. Insbesondere Papier mit [Na+, K+, Cl-] kann die Lebensdauer des Thermalkopfes drastisch verkürzen. Bitte vorsichtig arbeiten.*
9. *Nicht den Drucker betreiben, wenn Feuchtigkeit durch Beschlag usw. an der Vorderseite des Druckkopfes vorhanden ist.*

## 6. Einstellung des Endanäherungs-Sensors

Den Endanäherungs-Sensor auf folgende Weise justieren, damit er der Größe der verwendeten Papierrolle entspricht.

- ① Die Druckerabdeckung öffnen.
- ② Den Durchmesser der verwendeten Papierrolle ermitteln, und in der untenstehenden Tabelle die entsprechende Einstellung aufsuchen.
- ③ Die Spitze eines Kugelschreibers o.ä. Gegenstands in das Loch des Einstellers stecken. Beim Eindrücken des Einstellers nach oben oder unten schieben, um der Einstellung zu entsprechen, die zu dem verwendeten Rollenpapier paßt. Sicherstellen, daß der in der Abbildung durch einen Pfeil markierte Zapfen im Inneren der Rillen sitzt.

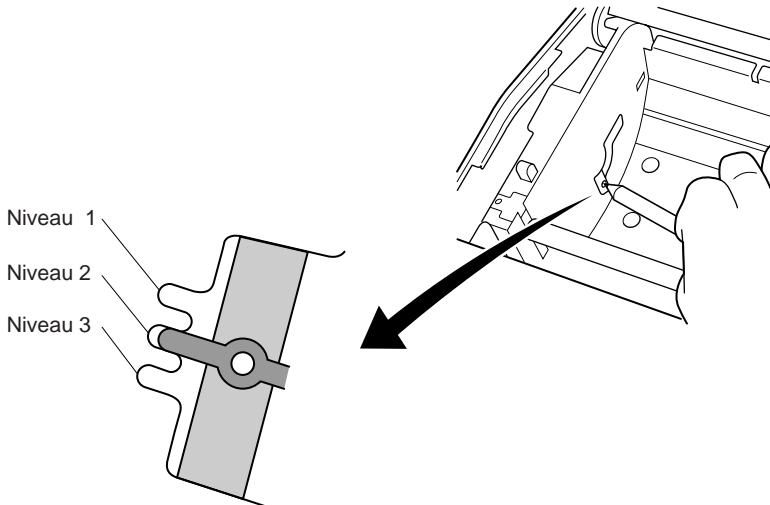

## Einstellwerte entsprechend des verwendeten Papiers

Papierdicke ( $\mu\text{m}$ )	Bei Verwendung einer Papierrolle mit einem Kern mit Innendurchmesser (A): $\phi 12$ und Außendurchmesser (B): $\phi 18$					
	Erkannter Durchmesser (C) (Etwa mm)			Rest papier (Etwa m)		
	Niveau 1	Niveau 2	Niveau 3	Niveau 1	Niveau 2	Niveau 3
65	$\phi 23$	$\phi 27$	$\phi 31$	2,5	4,9	7,7
75				2,1	4,2	6,7

Papierdicke ( $\mu\text{m}$ )	Bei Verwendung einer Papierrolle mit einem Kern mit Innendurchmesser (A): $\phi 25,4$ und Außendurchmesser (B): $\phi 32$					
	Erkannter Durchmesser (C) (Etwa mm)			Rest papier (Etwa m)		
	Niveau 1	Niveau 2	Niveau 3	Niveau 1	Niveau 2	Niveau 3
65	$\phi 36$	$\phi 40$	$\phi 44$	2,8	6,4	10,4
75				2,4	5,5	9,0
85				2,1	4,9	7,9
95				1,9	4,4	7,1
105				1,7	4,0	6,4
130				1,4	3,2	5,2
150				1,2	2,8	4,5

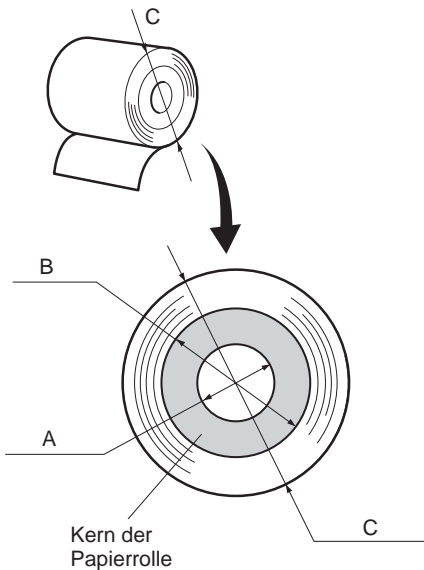

### Hinweis

- 1) Der Einsteller ist werkseitig auf Niveau 1 gestellt.
- 2) Die Abmessung C und die restliche Papierlänge sind berechnete Werte. Es können leichte Abweichungen zum tatsächlichen Wert auftreten.

## 7. Verhindern und Beheben von Papierstau

### 7-1. Verhindern von Papierstau

Das Papier soll beim Ausgeben und vor dem Schneiden nicht berührt werden. Wenn das Papier beim Ausgeben gedrückt oder gezogen wird, kann ein Papierstau, ein Abschneidfehler oder ein Zeilenvorschubfehler verursacht werden.

### 7-2. Beheben von Papierstau

Wenn ein Papierstau auftritt, beheben Sie ihn wie folgt.

- (1) Stellen Sie den Netzschalter auf Aus, um den Drucker auszuschalten.
- (2) Ziehen Sie den Hebel nach vorne, um die Druckerabdeckung zu öffnen.
- (3) Entfernen Sie das gestaute Papier.

**Hinweis:** Achten Sie darauf, den Drucker beim Entfernen des gestauten Papiers nicht zu beschädigen. Insbesondere der Thermaldruckkopf läßt sich leicht beschädigen; achten Sie darauf, ihn nicht zu berühren.

- (4) Stellen Sie sicher, daß das Papier gerade ausgerichtet ist, und schließen Sie die Druckerabdeckung vorsichtig.

**Hinweis 1:** Stellen Sie sicher, daß das Papier gerade ausgerichtet ist. Wenn die Druckerabdeckung bei schief liegendem Papier geschlossen wird, kann ein Papierstau auftreten.

**Hinweis 2:** Sperren Sie die Druckerabdeckung durch Drücken auf die Seiten. Nicht zum Schließen auf die Mitte drücken. Dabei kann es sein, daß die Abdeckung nicht richtig schließt.

- (5) Stellen Sie den Netzschalter in Ein-Stellung, um den Drucker einzuschalten. Stellen Sie sicher, daß die ERROR-LED nicht leuchtet.

**Hinweis:** Während die ERROR-LED leuchtet, akzeptiert der Drucker keine Befehle wie Druckbefehl; stellen Sie deshalb sicher, daß die Abdeckung richtig geschlossen ist.

## 8. Regelmäßige Reinigung

Die Druckzeichen können durch Ansammlung von Papierstaub und anderem Schmutz unscharf werden. Um das zu verhindern, muß im Papierhalter und in der Papiertransportstufe angesammelter Staub von Zeit zu Zeit entfernt werden. Diese Reinigung sollte einmal alle sechs Monate oder einmal nach jeder Million Zeilen ausgeführt werden.

### 8-1. Reinigen des Thermalkopfes

Zum Entfernen von schwärzlichem Staub auf der Oberfläche des Thermalkopfes diesen mit Isopropylalkohol (IPA) abwischen.

**Hinweis:** Der Thermalkopf läßt sich leicht beschädigen. Zum Abwischen immer einen sehr weichen Lappen verwenden und sicherstellen, daß er nicht zerkratzt wird.

### 8-2. Reinigen des Papierhalters

Verwenden Sie einen weichen Lappen zur Entfernung von Papierstaub vom Papierhalter und aus der Papiertransportstufe.

# INDICE

<b>1. Identificazione delle parti e nomenclatura .....</b>	<b>61</b>
<b>2. Parti soggette a consumo e trasformatore CA .....</b>	<b>63</b>
<b>3. Cavi di collegamento e trasformatore CA .....</b>	<b>65</b>
3-1. Cavo interfaccia .....	65
3-2. Collegamento ad un'unità periferica .....	67
3-3. Collegamento del trasformatore CA opzionale .....	68
3-4. Accensione .....	69
<b>4. Pannello di controllo e altre funzioni .....</b>	<b>70</b>
4-1. Pannello di controllo .....	70
4-2. Errori .....	70
4-3. Stampa automatica .....	72
<b>5. Inserimento del rotolo di carta .....</b>	<b>74</b>
<b>6. Regolazione del sensore di esaurimento prossimo .....</b>	<b>76</b>
<b>7. Prevenzione e soluzione degli inceppamenti della carta .....</b>	<b>78</b>
7-1. Prevenzione degli inceppamenti della carta .....	78
7-2. Eliminazione degli inceppamenti della carta .....	78
<b>8. Pulizia periodica .....</b>	<b>79</b>
8-1. Pulizia della testina termica .....	79
8-2. Pulizia del comparto carta .....	79
<b>APPENDICE .....</b>	<b>80</b>

*L'Appendice appare solo nella sezione in inglese di questo manuale.*

Visitare il seguente indirizzo URL

[http://www.star-micronics.co.jp/service/sp\\_sup\\_e.htm](http://www.star-micronics.co.jp/service/sp_sup_e.htm)

per accedere alla versione più recente del manuale.

# 1. Identificazione delle parti e nomenclatura

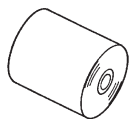
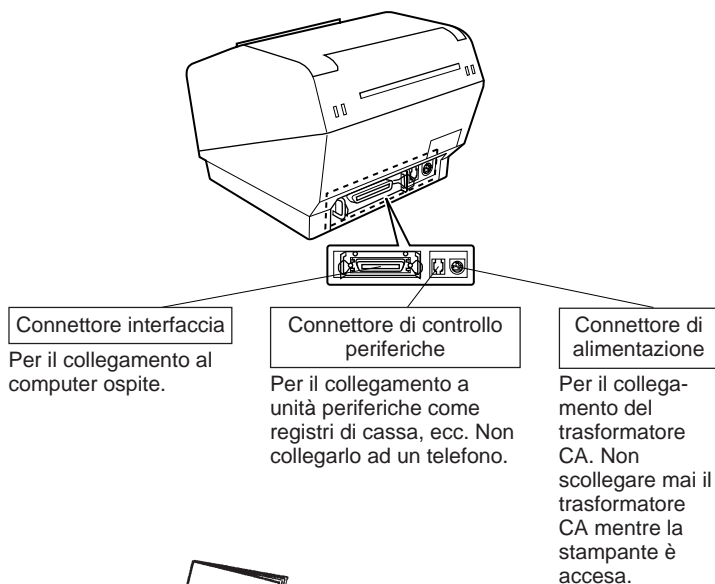
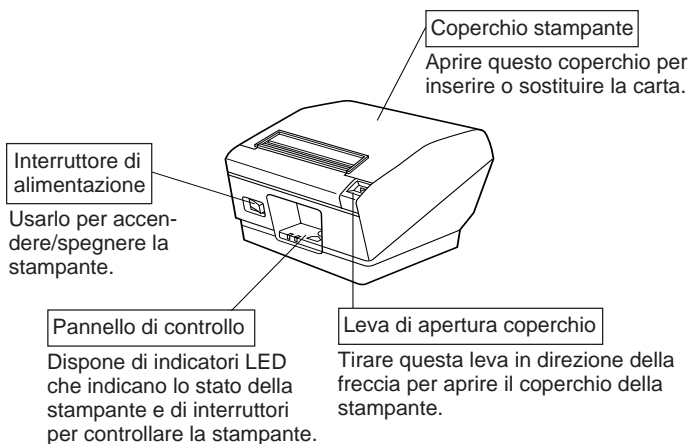

Carta in rotolo



Manuale dell'utilizzatore



Anello di ferrite

(Solo modello a interfaccia parallelo)



Fascetta di fissaggio

(Solo modello a interfaccia parallelo)



## *Scelta di un luogo per la stampante*

Prima di disimballare la stampante, decidere dove si desidera installarla. Tenere presenti i seguenti punti.

- ✓ Scegliere una superficie stabile e in piano, dove la stampante non sia esposta a vibrazioni.
- ✓ La presa di corrente che si intende usare per la stampante deve essere vicina e libera da ostacoli.
- ✓ La stampante deve essere abbastanza vicina al computer da permettere il collegamento tra i due.
- ✓ Assicurarsi che la stampante non sia esposta alla luce solare diretta.
- ✓ Assicurarsi che la stampante sia lontana da caloriferi e altre fonti di calore elevato.
- ✓ Assicurarsi che l'area circostante sia pulita, asciutta e priva di polvere.
- ✓ Assicurarsi che la stampante sia collegata ad una presa di corrente affidabile. Non deve essere la stessa presa di corrente di copiatrici, frigoriferi e altre apparecchiature che causano picchi di corrente.
- ✓ Assicurarsi che la stanza dove si usa la stampante non sia troppo umida.

## 2. Parti soggette a consumo e trasformatore CA

Quando le parti soggette a consumo si sono esaurite, usare quelle specificate nella seguente tabella. Assicurarsi di usare il trasformatore CA specificato nella tabella. L'uso di parti soggette a consumo o di un trasformatore CA diversi da quanto specificato nella tabella può causare danni alla stampante, incendi o scosse elettriche.

### (1) Carta in rotolo specifiche

Carta termica

Spessore: 65~150  $\mu\text{m}$

Larghezza: 111,5 $\pm$ 0,5 mm

Diametro esterno rullo:  $\phi$ 100 mm or less

Larghezza carta del rullo di raccolta: 112 $^{+0,3}_{-1}$  mm

Diametro interno/esterno nucleo

<b>Spessore carta</b>	<b>Nucleo: esterno</b>	<b>Nucleo: interno</b>
65~75 $\mu\text{m}$	$\phi$ 18 $\pm$ 1 mm	$\phi$ 12 $\pm$ 1 mm
65~75 $\mu\text{m}$	$\phi$ 32 $\pm$ 1 mm	$\phi$ 25,4 mm
75~150 $\mu\text{m}$	$\phi$ 32 $\pm$ 1 mm	$\phi$ 25,4 mm

Superficie stampata: Bordo esterno del rotolo

Maneggio dell'estremità finale: Non usare colla o adesivi per fissare la carta del rotolo o il suo nucleo.

Non piegare l'estremità finale della carta.

### (2) Carta consigliata

Mitsubishi Paper Mills Limited

P220AG (carta di tipo normale), 65  $\mu\text{m}$  (spessore)

HP220A (carta a stabilità immagine alta), 65  $\mu\text{m}$  (spessore)

HP220AB-1 (carta a stabilità immagine alta), 75  $\mu\text{m}$  (spessore)

P220AB (carta di tipo normale, biglietti scheda), 85  $\mu\text{m}$  (spessore)

P220AC-1 (carta di tipo normale, biglietti scheda), 95  $\mu\text{m}$  (spessore)

P220AC (carta di tipo normale, biglietti scheda), 105  $\mu\text{m}$  (spessore)

P220AD (carta di tipo normale, biglietti scheda), 130  $\mu\text{m}$  (spessore)

P220AE-1 (carta di tipo normale, biglietti scheda), 150  $\mu\text{m}$  (spessore)

Oji Paper Co., Ltd.

PD150R (carta di tipo normale), 75  $\mu\text{m}$  (spessore)

PD160R (carta a stabilità immagine alta), 65/75  $\mu\text{m}$  (spessore)

Nippon Paper Industries

TF50KS-E2C (carta di tipo normale), 65  $\mu\text{m}$  (spessore)

A seconda del tipo e dello spessore della carta, può essere necessario cambiare le impostazioni per la densità di stampa. Per cambiare le impostazioni di densità, usare il comando di impostazione densità di stampa <ESC><RS>'d'n. Fare riferimento al manuale del programmatore separato per dettagli.

(3) Trasformatore CA (opzionale)

Nome modello: PS60-24 A

Ingresso: Da 100 a 240 V CA, 50/60 Hz

Uscita:  $24 \pm 5\%$  CC, 2,0 A (5,0 A carico 10 sec. mass.)

---

***Importante!***

*Accedere alla seguente URL per informazioni sulla carta consigliata.  
<http://www.star-micronics.co.jp/>*

---

## 3. Cavi di collegamento e trasformatore CA

### 3-1. Cavo interfaccia

#### 3-1-1. Installazione dell'anello di ferrite (solo modello a interfaccia parallelo)

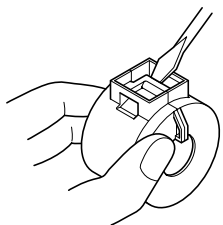

Anello di ferrite

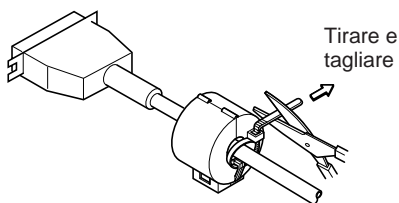
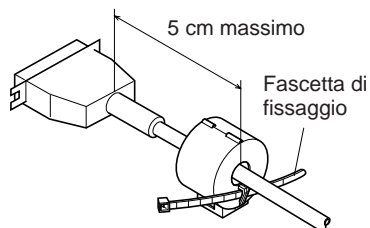
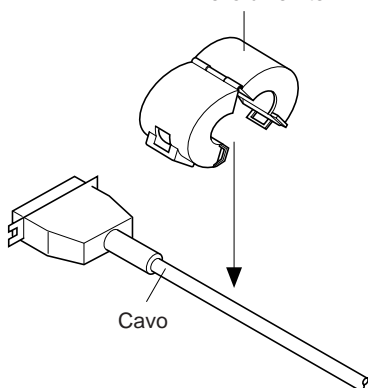

(1) Solo per il modello a interfaccia parallelo, fissare l'anello di ferrite al cavo come mostrato nell'illustrazione qui sotto.

(2) Far passare la fascetta di fissaggio attraverso l'anello di ferrite.

(3) Avvolgere la fascetta intorno al cavo e fissarla. Usare delle forbici per tagliare la parte in eccesso.

### 3-1-2. Collegamento del cavo interfaccia

**Nota:** Prima di collegare/scollegare il cavo interfaccia, assicurarsi che la stampante e tutti i dispositivi collegati alla stampante siano spenti. Inoltre assicurarsi che la spina del cavo di alimentazione sia scollegata dalla presa di corrente.

- (1) Collegare il cavo interfaccia al connettore sul pannello posteriore della stampante.
- (2) Nel caso di un interfaccia seriale, serrare le viti del connettore. Nel caso di un interfaccia parallelo, fissare i morsetti del connettore.

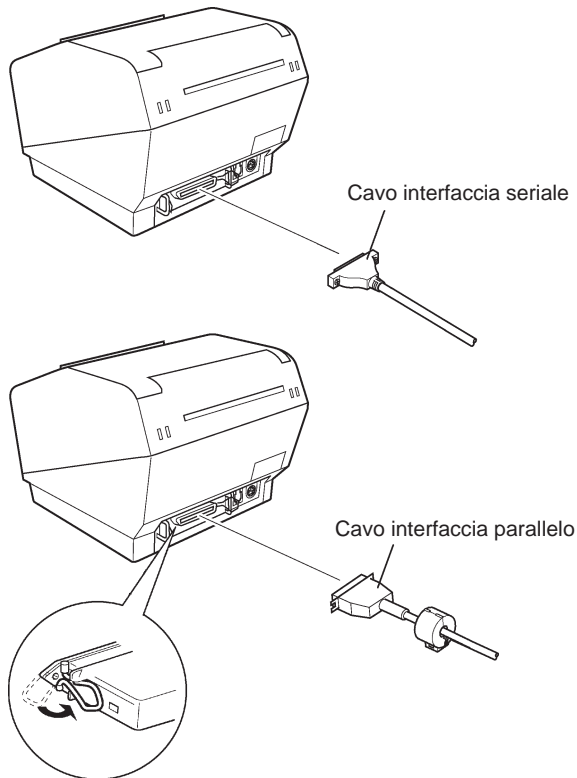

## 3-2. Collegamento ad un'unità periferica

Si può collegare un'unità periferica alla stampante usando una spina modulare. Di seguito descriviamo come installare l'anello di ferrite ed eseguire il collegamento. Vedere "Modulare necessario" a pagina 80 per dettagli sul tipo di spina modulare necessario. Notare che la stampante non è dotata di spina o filo modulare, che devono essere acquistati in base alle esigenze di impiego.

### ***Importante!***

Assicurarsi che la stampante sia spenta e scollegata dalla presa di corrente e che il computer sia spento prima di eseguire il collegamento.

- (1) Collegare il cavo di controllo periferiche al connettore sul pannello posteriore della stampante.

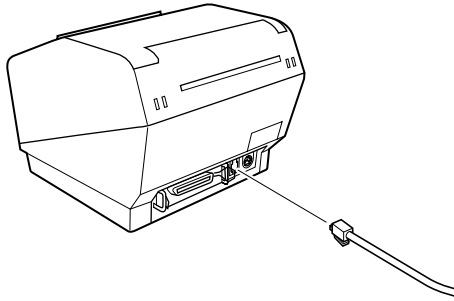

### 3-3. Collegamento del trasformatore CA opzionale

**Nota:** Prima di collegare/scollegare il trasformatore CA, assicurarsi che la stampante e tutti i dispositivi collegati alla stampante siano spenti. Inoltre assicurarsi che la spina del cavo di alimentazione sia scollegata dalla presa di corrente.

(1) Collegare il trasformatore CA al cavo di alimentazione.

**Nota:** Usare solo il trasformatore CA e cavo di alimentazione standard.

(2) Collegare il trasformatore CA al connettore sulla stampante.

(3) Collegare la spina del cavo di alimentazione ad una presa di corrente.

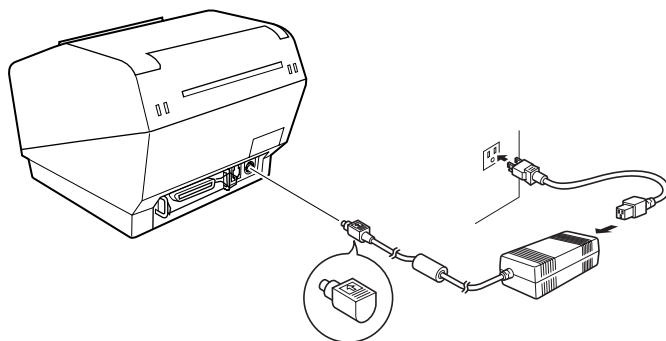

### 3-4. Accensione

Assicurarsi che il trasformatore CA sia stato collegato come indicato nella sezione 3-3.

(1) Regolare su ON l'interruttore di alimentazione situato sul davanti della stampante.

La spia POWER sul pannello di controllo si illumina.



---

#### ***Importante!***

*Consigliamo di scollegare la stampante dalla presa di corrente quando si prevede di non usarla per un lungo periodo. Per questo motivo, la stampante deve essere collocata in modo che la presa di corrente sia vicina e facilmente accessibile.*

---



## 4. Pannello di controllo e altre funzioni

### 4-1. Pannello di controllo

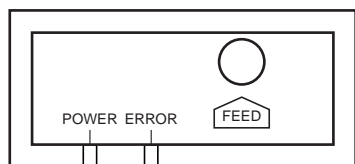

- ① Spia POWER (LED verde)  
Si illumina quando l'unità è accesa.
- ② Spia ERROR (LED rosso)  
Indica vari errori in combinazione con la spia POWER.
- ③ Tasto FEED  
Premere il tasto FEED per far avanzare la carta su rotolo.

### 4-2. Errori

#### 1) Errori con recupero automatico

Descrizione dell'errore	Spia POWER	Spia ERROR	Condizioni di recupero
Individuazione temperatura testina elevata	Lampeggia a intervalli di 0,5 secondi	Spenta	Recupero automatico dopo che la testina di stampa si è raffreddata.
Errore di coperchio aperto	Accesa	Accesa	Recupero automatico con la chiusura del coperchio stampante.

#### 2) Errore con recupero

Descrizione dell'errore	Spia POWER	Spia ERROR	Condizioni di recupero
Errore di taglio carta	Accesa	Lampeggia a intervalli di 0,125 secondi	Recupero se la taglierina ritorna alla posizione di riposo dopo che si è spenta e riaccesa l'unità.

#### Nota

- 1) Se la taglierina non ritorna alla posizione di riposo, o non esegue il movimento iniziale, il recupero non è possibile.
- 2) Se la carta è inceppata spegnere l'unità, eliminare l'inceppamento e quindi riaccendere.

### 3) Errori senza recupero

Descrizione dell'errore	Spia POWER	Spia ERROR	Condizioni di recupero
Errore RAM	Spenta	Accesa	Questo errore è senza recupero. Consultare il rivenditore per riparazioni.
Errore EPROM	Lampeggia a intervalli di 0,25 secondi	Lampeggia a intervalli di 0,25 secondi	Questo errore è senza recupero. Consultare il rivenditore per riparazioni.
Errore termistore	Lampeggia a intervalli di 0,5 secondi	Lampeggia a intervalli di 0,5 secondi	
Errore alimentazione	Lampeggia a intervalli di 1 secondo	Lampeggia a intervalli di 1 secondo	Questo errore è senza recupero. Consultare il rivenditore per riparazioni.

#### Nota

- 1) Se si verifica un errore senza recupero, spegnere immediatamente l'unità.
- 2) Quando si verifica un errore alimentazione, esiste la possibilità che l'unità di alimentazione sia guasta.

Per altri errori senza recupero, consultare il rivenditore per riparazioni.

### 4) Errori di rilevamento carta

Descrizione dell'errore	Spia POWER	Spia ERROR	Condizioni di recupero
Errore di carta esaurita	Accesa	Lampeggia a intervalli di 0,5 secondi	Recupero automatico quando si inserisce un nuovo rullo di carta e si chiude il coperchio stampante.
Carta quasi esaurita	Accesa	Lampeggia a intervalli di 0,2 secondi	Le spie indicano che la carta è quasi finita, ma la stampante continua a stampare.

## 4-3. Stampa automatica

### (1) Stampa di prova

Accendere l'unità tenendo premuto il tasto FEED.

La stampa di prova viene eseguita nell'ordine di numero di versione, impostazioni degli interruttori DIP e ordine dei caratteri. Se si preme il tasto FEED alla fine della stampa di prova, sono stampati ripetutamente solo i caratteri.

```
*** TSP800 Ver1.00
```

```
Interface : Parallel
```

```
DIP Switch 1
```

```
Sw 12345678
```

```
On ******
```

```
Off
```

```
1,2 = Emulation : Star Line
```

```
4 = Sensor Adjustment : Off
```

```
5 = INIT Reset : Enable
```

```
6 = BUSY : All
```

```
7 = ASB : Disable
```

```
Memory Switch
```

```
FEDCBA9876543210 HEX.
```

```
<0> 0000000000000000 0000
```

```
<1> 0000000000000000 0000
```

```
0123456789::<=>?@ABCDEF  
.-./0123456789::<=>?@ABCDEF  
.-./0123456789::<=>?@ABCDEF  
./0123456789::<=>?@ABCDEF  
/0123456789::<=>?@ABCDEF  
0123456789::<=>?@ABCDEF  
123456789::<=>?@ABCDEF  
23456789::<=>?@ABCDEF  
3456789::<=>?@ABCDEF  
456789::<=>?@ABCDEF  
56789::<=>?@ABCDEF
```

ITALIANO

## (2) Modo di scaricamento esadecimale

Aprire il coperchio stampante, quindi accendere l'unità tenendo premuto il tasto FEED. Quando si chiude il coperchio viene stampato "\*\*\* HEX DUMP PRINTING\*\*\*" e la stampante passa al modo di scaricamento esadecimale. Ciascuno dei segnali inviati dal computer alla stampante viene stampato come codice esadecimale.

Questa funzione permette di controllare se un codice di controllo inviato alla stampante dal programma usato è corretto oppure no. L'ultima riga non viene stampata se i suoi dati con costituiscono una riga completa. Tuttavia, se si preme il tasto FEED, viene stampata l'ultima riga. Per disattivare questo modo è necessario spegnere completamente la stampante.

\*\*\* HEX DUMP PRINTING \*\*\*

20 21 22 23 24 25 26 27	!'"\$%&'
28 29 2A 2B 2C 2D 2E 2F	()*+,-./
30 31 32 33 34 35 36 37	01234567
38 39 3A 3B 3C 3D 3E 3F	89:;<=>?
40 41 42 43 44 45 46 47	@ABCDEFGH
48 49 4A 4B 4C 4D 4E 4F	IJKLMNOP
50 51 52 53 54 55 56 57	QRSTUVWXYZ

## 5. Inserimento del rotolo di carta

Assicurarsi di usare carta su rotolo che corrisponde alle specifiche della stampante.

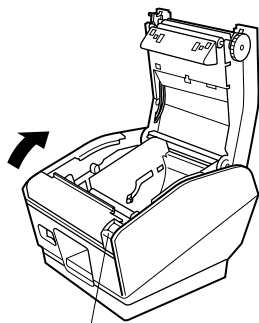

Leva di apertura coperchio

Spingere la leva di apertura coperchio e aprire il coperchio stampante.

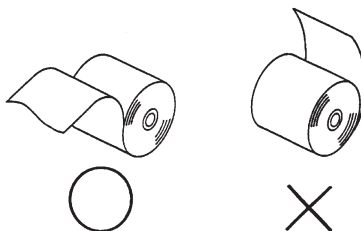

Carta su rotolo

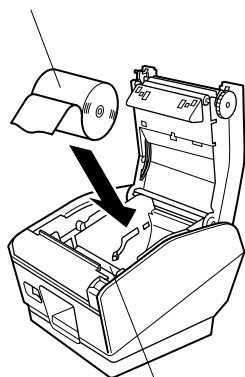

Barra di tensione

Osservando l'orientamento del rotolo, inserire il rotolo di carta nel vano e tirare il bordo iniziale della carta verso di sé.

**Nota 1:** Quando si usa carta di uno spessore che richiede l'uso della barra di tensione ( $65 \mu\text{m} \leq \text{spessore carta} < 100 \mu\text{m}$ ), assicurarsi di non far passare la carta sotto la barra di tensione.

**Note 2:** Quando si usa carta di uno spessore che non richiede l'uso della barra di tensione ( $100 \mu\text{m} \leq \text{spessore carta} \leq 150 \mu\text{m}$ ), rimuovere le due viti sui due lati della barra di tensione con un cacciavite e rimuovere la barra di tensione prima di inserire la carta. Normalmente questo procedimento (rimozione della barra di tensione) è già stato eseguito dal rivenditore.

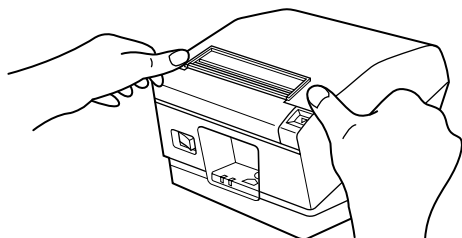

Premere su entrambi i lati del coperchio stampante per chiudere.

**Nota:** Assicurarsi che il coperchio stampante sia saldamente chiuso.

---

### **Importante!**

1. *Non toccare la lama della taglierina.*
  - *All'interno della fessura di uscita carta si trova una taglierina. Non mettere mai la mano nella fessura di uscita della carta durante la stampa e non mettere mai la mano nella fessura anche quando la stampa non è in corso.*
  - *Il coperchio della stampante può essere aperto quando si sostituisce la carta. Tuttavia, poiché la lama della taglierina si trova all'interno del coperchio stampante, fare attenzione a non avvicinare eccessivamente le mani o il volto alla lama della taglierina.*
2. *Non azionare la leva di apertura del coperchio mentre si preme sul coperchio stampante con la mano.*
3. *Non estrarre la carta con il coperchio stampante chiuso.*
4. *L'elemento riscaldante e il circuito integrato pilota sulla testina termica si danneggiano facilmente. Non toccarli con oggetti metallici, carta vetrata, ecc.*
5. *Durante la stampante e subito dopo, l'area circostante la testina termica è molto calda. Non toccare perché si potrebbero subire ustioni.*
6. *Se l'elemento riscaldante della testina termica si è sporcato perché è stato toccato con le mani, la qualità di stampa può risentirne. Non toccare l'elemento riscaldante della testina termica.*
7. *Esiste il rischio di danni al circuito integrato pilota della testina di termica nel caso di elettricità statica. Si prega di fare attenzione.*
8. *La qualità di stampa e la vita utile della testina termica non possono essere garantite se si usa qualsiasi carta diversa da quella consigliata. In particolare, carta contenente [Na<sup>+</sup>, K<sup>+</sup>, Cl<sup>-</sup>] può ridurre drasticamente la vita utile della testina termica. Si prega di fare attenzione.*
9. *Non usare la stampante se è presente umidità sulla parte anteriore della testina, a causa di condensa, ecc.*

## 6. Regolazione del sensore di esaurimento prossimo

Usare il seguente procedimento per regolare il sensore di esaurimento prossimo in modo che sia compatibile con le dimensioni del rotolo di carta usato.

- ① Aprire il coperchio stampante.
- ② Misurare il diametro del rotolo di carta usato e trovare l'impostazione necessaria nella tabella sotto.
- ③ Inserire la punta di una penna a sfera o un oggetto appuntito simile nel foro sul regolatore. Tenendo premuto il regolatore, farlo scorrere in alto o in basso alla regolazione corrispondente al rotolo di carta usato.

Assicurarsi che la sporgenza indicata da una freccia nell'illustrazione sia in una delle scanalature.

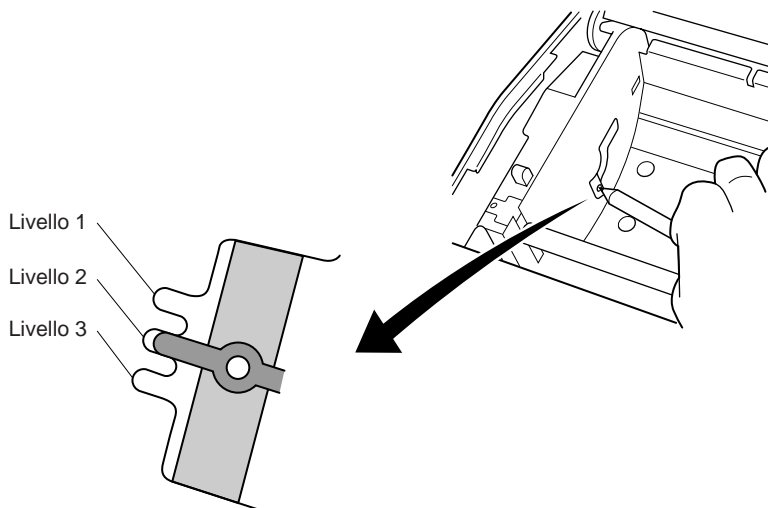

## Valore di regolazione secondo la carta usata

Spessore carta ( $\mu\text{m}$ )	Quando si usa un rotolo di carta con nucleo di diametro interno (A): $\phi 12$ , diametro esterno (B): $\phi 18$					
	Diametro individuato (C) (mm circa)			Lunghezza carta rimanente (m circa)		
	Livello 1	Livello 2	Livello 3	Livello 1	Livello 2	Livello 3
65	$\phi 23$	$\phi 27$	$\phi 31$	2,5	4,9	7,7
75				2,1	4,2	6,7

Paper thick- ness ( $\mu\text{m}$ )	Quando si usa un rotolo di carta con nucleo di diametro interno (A): $\phi 25,4$ , diametro esterno (B): $\phi 32$					
	Diametro individuato (C) (mm circa)			Lunghezza carta rimanente (m circa)		
	Livello 1	Livello 2	Livello 3	Livello 1	Livello 2	Livello 3
65	$\phi 36$	$\phi 40$	$\phi 44$	2,8	6,4	10,4
75				2,4	5,5	9,0
85				2,1	4,9	7,9
95				1,9	4,4	7,1
105				1,7	4,0	6,4
130				1,4	3,2	5,2
150				1,2	2,8	4,5

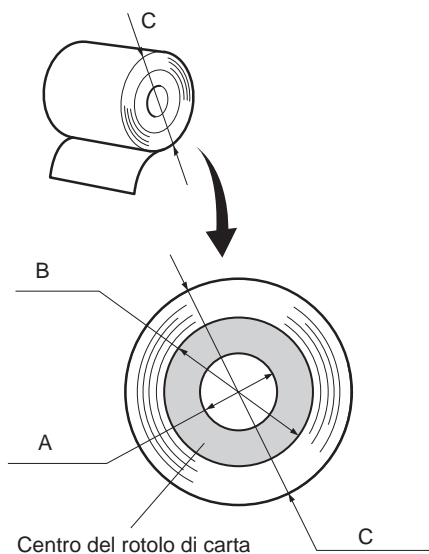

### Nota

- 1) Il regolatore è stato impostato sul livello 1 in fabbrica.
- 2) La dimensione C e la lunghezza di carta rimanente sono valori calcolati. Si possono avere leggere variazioni nell'uso effettivo.



## 7. Prevenzione e soluzione degli inceppamenti della carta

### 7-1. Prevenzione degli inceppamenti della carta

La carta non deve essere toccata durante l'espulsione e prima che sia tagliata. Se si preme o si tira la carta durante l'espulsione si può verificare un inceppamento della carta, un mancato taglio della carta o un avanzamento di riga mancato.

### 7-2. Eliminazione degli inceppamenti della carta

Se si verifica un inceppamento della carta, eliminarlo come descritto di seguito.

- (1) Regolare l'interruttore di alimentazione su OFF per spegnere la stampante.
- (2) Tirare la leva verso di sé per aprire il coperchio stampante.
- (3) Rimuovere la carta inceppata.

**Nota:** Fare attenzione a non danneggiare la stampante quando si rimuove la carta inceppata. Poiché la testina di stampa in particolare viene danneggiata facilmente, fare attenzione a non toccarla.

- (4) Collocare diritto il rotolo di carta e chiudere delicatamente il coperchio stampante.

**Nota 1:** Assicurarsi che la carta sia ben diritta. Se si chiude il coperchio stampante con la carta storta, si può verificare un inceppamento della carta.

**Nota 2:** Bloccare il coperchio stampante premendo in basso sui lati. Non tentare di chiuderlo premendo sul centro. Il coperchio potrebbe non bloccarsi correttamente.

- (5) Regolare su ON l'interruttore di alimentazione per accendere la stampante. Assicurarsi che la spia ERROR non sia illuminata.

**Nota:** Mentre la spia ERROR è illuminata, la stampante non accetta alcun comando come il comando di stampa, per cui assicurarsi che il coperchio della stampante sia bloccato correttamente.

## 8. Pulizia periodica

I caratteri stampati possono diventare parzialmente poco chiari a causa dell'accumulo di polvere di carta e sporcizia. Per evitare tale problema, è necessario rimuovere periodicamente la polvere di carta accumulata nel comparto carta, nella sezione di trasporto carta e sulla superficie della testina termica. Si consiglia di eseguire questa pulizia una volta ogni sei mesi oppure ogni milione di righe stampate.

### 8-1. Pulizia della testina termica

Per rimuovere la polvere nerastra accumulata sulla superficie della testina di stampa, passarla con alcool (IPA)

**Nota:** La testina termica si danneggia facilmente, per cui pulirla delicatamente con un panno morbido. Fare attenzione a non graffiarla durante la pulizia.

### 8-2. Pulizia del comparto carta

Usare un panno morbido per eliminare la polvere di carta dal comparto carta e dalla sezione di trasporto della carta.

# Appendix A: Specifications

## A-1. General Specifications

- |                             |  |
|-----------------------------|--|
| (1) Printing method         | Direct line thermal printing   |
| (2) Print speed             | Max. 1200 dots/sec. (150 mm/sec.)  |
| (3) Dot density             | 203 dpi: 8 dots/mm (0.125 mm/dot)  |
| (4) Printing width          | Max. 104 mm  |
| (5) Number of print columns | 69 (12 × 24 dots)  |
| (6) Roll paper              | Refer to chapter 2 for details on the recommended roll paper.<br>Paper width: 111.5 ± 0.5 mm<br>Roll diameter: ø100 mm or less |
| (7) Overall dimension       | 180 (W) × 213 (D) × 148 (H) (mm)   |
| (8) Weight                  | Approx. 1.7 kg   |
| (9) Noise Approx.           | 55 dB  |

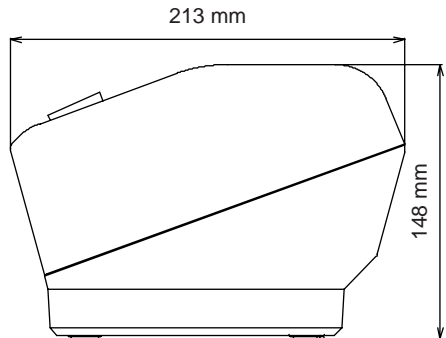
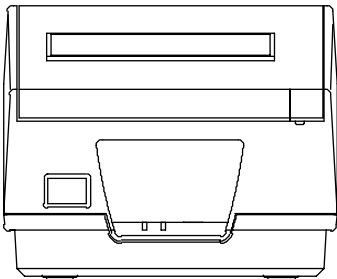
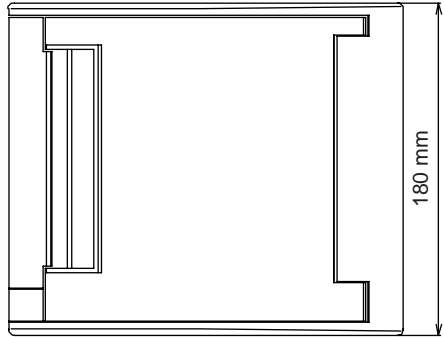

## A-2. Auto Cutter Specifications

- (1) Cutting frequency      Max. 20 cuts per minute  
(2) Thickness of paper      0.065 ~ 0.15 mm

## A-3. Interface

- (1) Interface      RS232C serial interface or Two-way parallel interface (IEEE1284)  
(2) Command      Star commands

## A-4. Electrical Characteristics

- (1) Input Voltage      DC 24V $\pm$ 10%  
(2) Current Consumption      Operating: Approx. 1.8 A (at ASCII printing)  
Peak:      Approx. 10 A (at print duty 100%)  
Stand-by:      Approx. 0.1 A

### (3) Power Connector

Pin No.	Function
1	Drive power
2	Signal GND
3	N.C.
Shell	Frame ground

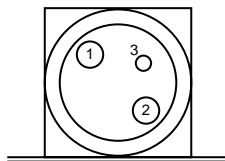

<Viewed from Connector Surface>

### **Important!**

- When using a printer power supply other than the optional AC adaptor (PS60-24A), be sure that the following cautions are observed.
- Use a power supply of DC 24 V  $\pm$  10% and more than 2.0 A (5.0 A Load 10 sec. Min).
- Be careful about installing the printer in an area where there is noise. Take the appropriate measures to protect against electrostatic AC line noise, etc.

## A-5. Environmental Requirements

### (1) Operating

Temperature

5°C to 45°C

Humidity

10% to 90% RH (without condensation)

(%RH)

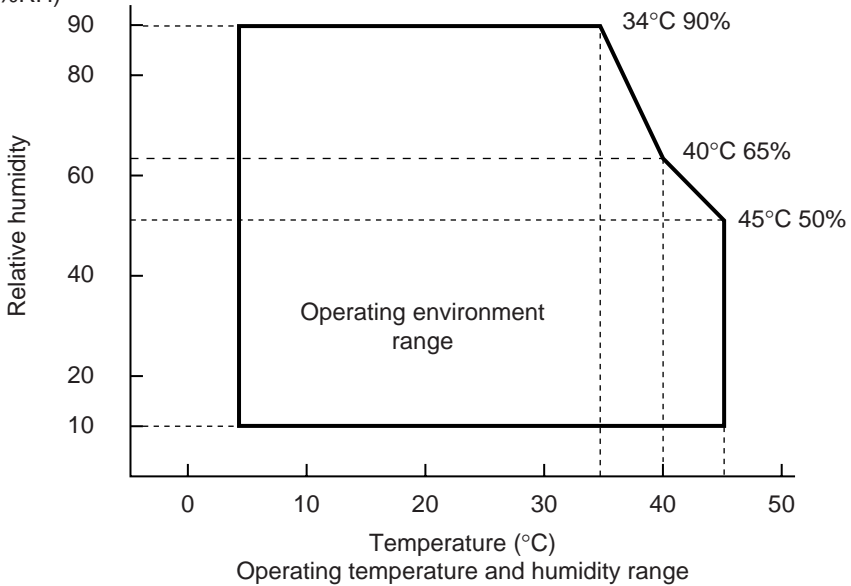

### (2) Transport/storage (except for paper)

Temperature

-20°C to 60°C

Humidity

10% to 90% RH (without condensation)

## A-6. Reliability

### (1) MCBF

37 million lines (based on an average printing rate of 12.5% with paper thickness in the range 65 µm to 75 µm)

### (2) Print head life

Pulse durability: 100,000,000 pulses or more

Wear resistance: 100 km or more

### (3) Cutter life

1.0 million cuttings (if the paper thickness is between 65 and 75 µm)

0.6 million cuttings (if the paper thickness is between 75 and 100 µm)

0.3 million cuttings (if the paper thickness is between 100 and 130 µm)

0.15 million cuttings (if the paper thickness is between 130 and 150 µm)

## A-7. Black mark specifications

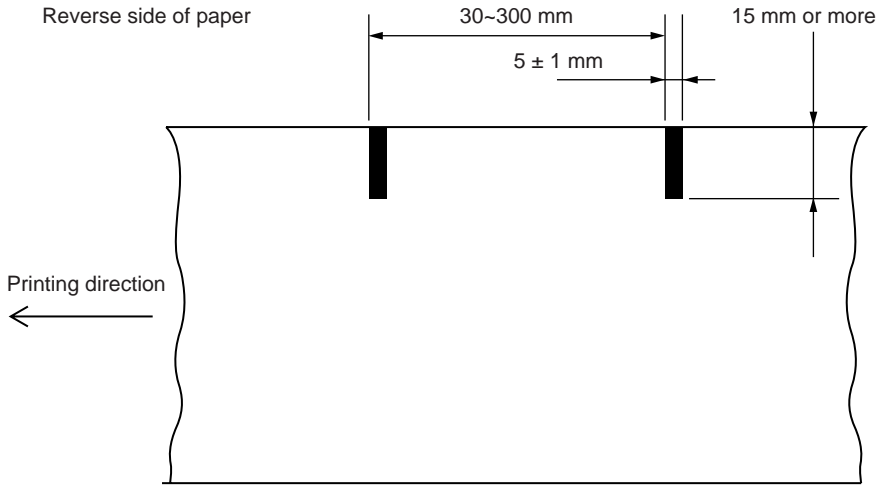

Make the PCS value of the black marks 0.90 or more.

**Note** The printing start accuracy, based on detection of the black marks, is  $\pm 2$  mm with respect with the standard printing area. For the printing length, taking into account the initial surrounding air temperature and the deviation in platen diameters during manufacturing, the accuracy is  $\pm 2\%$  with respect to the settings values. Taking into account the working life of the printer, during printing layout be sure to allow for a maximum error of  $-5\%$  with respect to the settings values, when using preprinted paper.

## Appendix B: Dip Switch Setting

Two DIP switches are provided at the bottom of the printer, and can be set as given in the table below. Be sure to set the power switch to off before changing the settings. It is recommended to use a pointed item like a pen or flat-blade driver screw to change the settings. The settings will become effective when the power switch is set to on again.

The following is the procedure for changing the settings on DIP switches.

1. Make sure the printer is turned off.
2. Remove the screw from the DIP switch cover. Then take off the DIP switch cover, as shown in the illustration below.

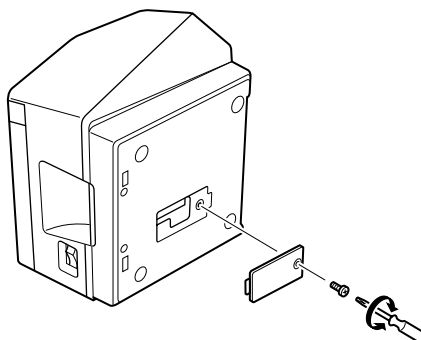

3. Set the switches using a pointed tool, such as a pen or flat-blade screwdriver.
4. Replace the DIP switch cover. Then secure it with the screw. The new settings take effect when you turn on the printer.

## B-1. Parallel Interface Type

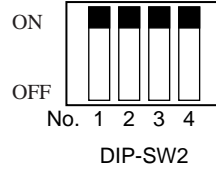
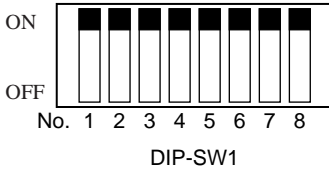

DIP-SW 1

Switch 1-1	Switch 1-2	Command emulation
ON	ON	Star Line Mode
OFF	ON	Star Page Mode
ON	OFF	DP8340 Mode

The factory settings of DIP switch are all on.

The functions of switches 1-3 through 1-8 will change according to the command emulation that has been set using switches 1-1 and 1-2.

### (1) Star Line mode

Switch	Function	ON	OFF
1-1	Command emulation	Always ON	
1-2	Command emulation	Always ON	
1-3	Should not be changed (Should be set to on)		
1-4	Sensor adjustment	Invalid	Valid
1-5	Pin #31 (INIT) reset signal	Valid	Invalid
1-6	Handshaking conditions (conditions for BUSY)	Offline or receive buffer full	Receive buffer full
1-7	Automatic status back function	Invalid	Valid
1-8	Should not be changed (Should be set to on)		

### (2) Star Page mode

Switch	Function	ON	OFF
1-1	Command emulation	Always OFF	
1-2	Command emulation	Always ON	
1-3	Should not be changed (Should be set to on)		
1-4	Sensor adjustment	Invalid	Valid
1-5	Pin #31 (INIT) reset signal	Valid	Invalid
1-6	Handshaking conditions (conditions for BUSY)	Offline or receive buffer full	Receive buffer full
1-7	Automatic status back function	Invalid	Valid
1-8	Should not be changed (Should be set to on)		



### (3) DP8340 mode

Switch	Function	ON	OFF
1-1	Command emulation	Always ON	
1-2	Command emulation	Always OFF	
1-3	Control cord CR	Invalid	Same as LF
1-4	Character table (See below)		
1-5	Character table (See below)		
1-6	International character set (See below)		
1-7	International character set (See below)		
1-8	International character set (See below)		

#### Character Table

Switch	USA & Europe	IBM#1	IBM#2	JAPAN
1-4	ON	OFF	ON	OFF
1-5	ON	ON	OFF	OFF

#### International Character Set

Switch	USA	France	Germany	England	Denmark	Sweden 1	Italy	Spain 1
1-6	ON	OFF	ON	OFF	ON	OFF	ON	OFF
1-7	ON	ON	OFF	OFF	ON	ON	OFF	OFF
1-8	ON	ON	ON	ON	OFF	OFF	OFF	OFF

#### DIP-SW 2

Switch	Function	ON	OFF
1	Flash memory rewrite	Invalid	Valid
2	Should not be changed (Should be set to off)	—	—
3	Boot block rewrite	Invalid	Valid
4	Always ON	Should be set to on	

The factory settings of DIP switch are all on.

## B-2. Serial Interface Type

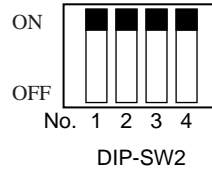
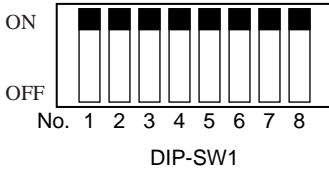

DIP-SW 1

Switch 1-1	Switch 1-2	Command emulation
ON	ON	Star Line Mode
OFF	ON	Star Page Mode
ON	OFF	DP8340 Mode

The factory settings of DIP switch are all on.

The functions of switches 1-3 through 1-8 will change according to the command emulation that has been set using switches 1-1 and 1-2.

### (1) Star Line mode

Switch	Function	ON	OFF
1-1	Command emulation	Always ON	
1-2	Command emulation	Always ON	
1-3	Should not be changed (Should be set to on)		
1-4	Sensor adjustment	Invalid	Valid
1-5	Should not be changed (Should be set to on)		
1-6	Handshaking conditions (conditions for BUSY)	Offline or receive buffer full	Receive buffer full
1-7	Automatic status back function	Invalid	Valid
1-8	Should not be changed (Should be set to on)		

### (2) Star Page mode

Switch	Function	ON	OFF
1-1	Command emulation	Always OFF	
1-2	Command emulation	Always ON	
1-3	Should not be changed (Should be set to on)		
1-4	Sensor adjustment	Invalid	Valid
1-5	Should not be changed (Should be set to on)		
1-6	Handshaking conditions (conditions for BUSY)	Offline or receive buffer full	Receive buffer full
1-7	Automatic status back function	Invalid	Valid
1-8	Should not be changed (Should be set to on)		

### (3) DP8340 mode

Switch	Function	ON	OFF
1-1	Command emulation	Always ON	
1-2	Command emulation	Always OFF	
1-3	Control cord CR	Invalid	Same as LF
1-4	Character table (See below)		
1-5	Character table (See below)		
1-6	International character set (See below)		
1-7	International character set (See below)		
1-8	International character set (See below)		

#### Character Table

Switch	USA & Europe	IBM#1	IBM#2	JAPAN
1-4	ON	OFF	ON	OFF
1-5	ON	ON	OFF	OFF

#### International Character Set

Switch	USA	France	Germany	England	Denmark	Sweden 1	Italy	Spain 1
1-6	ON	OFF	ON	OFF	ON	OFF	ON	OFF
1-7	ON	ON	OFF	OFF	ON	ON	OFF	OFF
1-8	ON	ON	ON	ON	OFF	OFF	OFF	OFF

#### DIP-SW 2

Switch	Function	ON	OFF
2-1	Flash memory rewrite	Invalid	Valid
2-2	Should not be changed (Should be set to on)	—	—
2-3	Boot block rewrite	Invalid	Valid
2-4	Always ON	Should be set to on	

The factory settings of DIP switch are all on.

The following is the procedure for changing the settings on DIP switch No. 3.

1. Turn off the printer and all components connected to it.
2. Remove the 2 screws.
3. Remove the serial interface board unit.
4. Change the setting of the DIP switches.
5. Replace the serial interface board unit.  
Then secure it with the screws.
6. Turn on the printer and all components connected to it.

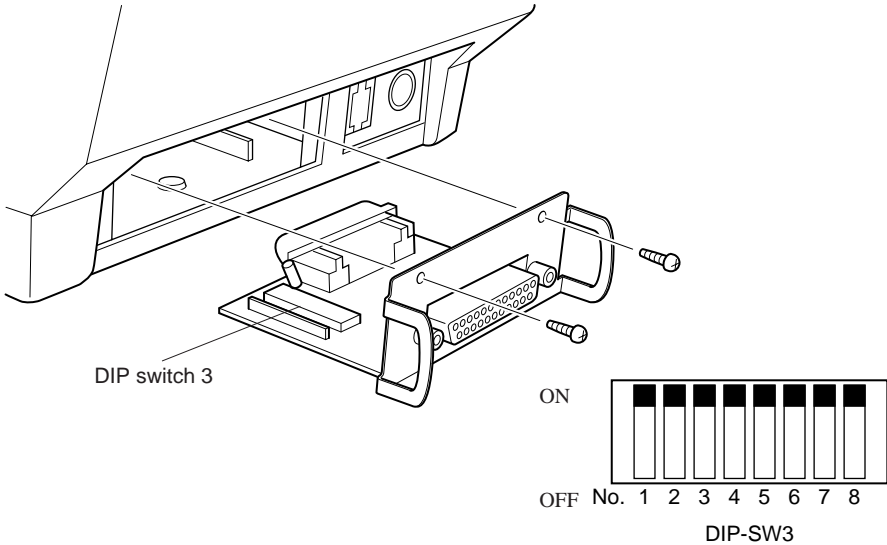

The factory settings of DIP switch are all on.

### DIP-SW 3

Switch	Function	ON	OFF
3-1	Baud Rate	See table below	
3-2			
3-3	Data Length	8 bits	7 bits
3-4	Parity Check	Disabled	Enabled
3-5	Parity	Odd	Even
3-6	Handshake	DTR	XON/XOFF
3-7	Should not be changed (Should be set to on)	—	—
3-8			

Baud Rate	Switch 3-1	Switch 3-2
4800BPS	OFF	ON
9600BPS	ON	ON
19200BPS	ON	OFF

# Appendix C: Parallel Interface

The two-way parallel interface is compatible with the IEEE1284 compatibility mode, nibble mode and byte mode. Refer to the separate programmer’s manual for details.

## Table of Connection Signals for Each Mode

Pin No.	Direction	Compatibility Mode Signal Name	Nibble Mode Signal Name	Byte Mode Sginal Name
1	In	nStrobe	Host Clock	Host Clock
2	In/Out	Data0	Data0	Data0
3	In/Out	Data1	Data1	Data1
4	In/Out	Data2	Data2	Data2
5	In/Out	Data3	Data3	Data3
6	In/Out	Data4	Data4	Data4
7	In/Out	Data5	Data5	Data5
8	In/Out	Data6	Data6	Data6
9	In/Out	Data7	Data7	Data7
10	Out	nAck	PtrClk	PtrClk
11	Out	Busy	PtrBusy/Data3,7	PtrBusy
12	Out	PError	AckDataReq/Data2,6	AckDataReq
13	Out	Select	Xflag/Data1,5	Xflag
14		N/C	HostBusy	HostBusy
15		N/C	—	—
16		Signal GND	Signal GND	Signal GND
17		Frame GND	Flame GND	Flame GND
18	OUT	+5V	+5V	+5V
19~30		Twisted Pair Return	Twisted Pair Return	Twisted Pair Return
31	In	nInit	nInit	nInit
32	Out	nFault	nDataAvail/Data0,4	nDataAvail
33		External GND	—	—
34		N/C	—	—
35		N/C	—	—
36	In	nSelectIn	1284Active	1284Active

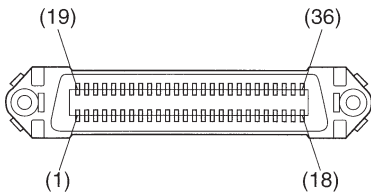

This connector mates with an Amphenol 57-30360 connector

Parallel interface connector (printer side)

# Appendix D: Serial Interface

## D-1. RS-232C Connector

Pin No.	Signal name	Direction	Function
1	F-GND	—	Frame ground
2	TXD	OUT	Transmission data
3	RXD	IN	Receive data
4	RTS	OUT	Request To Send: The printer sets this signal to “SPACE” when it is ready to send.
5	CTS	IN	The host sets this signal to “SPACE” when it is ready to send. NOTE: The printer does not monitor this signal.
6	DSR	IN	Not used
7	S-GND	—	Signal ground
8~10	N/C		Not used
11	RCH	OUT	This pin outputs the same signal as pin 20, to which it is connected.
12	N/C		Not used
13	S-GND	—	Signal ground
14	$\overline{\text{FAULT}}$	OUT	The printer sets this signal to “MARK” to indicate an error condition (machine error, no paper, etc.).
15~19	N/C		Not used
20	DTR	OUT	Indicates whether data receive from host is enabled or disabled. <b>DTR/DSR Communication Mode</b> Space when receive is enabled. <b>X-On/X-Off Communication Mode</b> Always space, except during following conditions: <ul style="list-style-type: none"> <li>• Period between reset and communication enabled</li> <li>• During self-test printing and dot alignment adjustment</li> </ul>
21~24	N/C		Not used
25	$\overline{\text{INIT}}$	IN	Not used

## D-2. Cable Connections

The followings are a recommended interface cable connections.

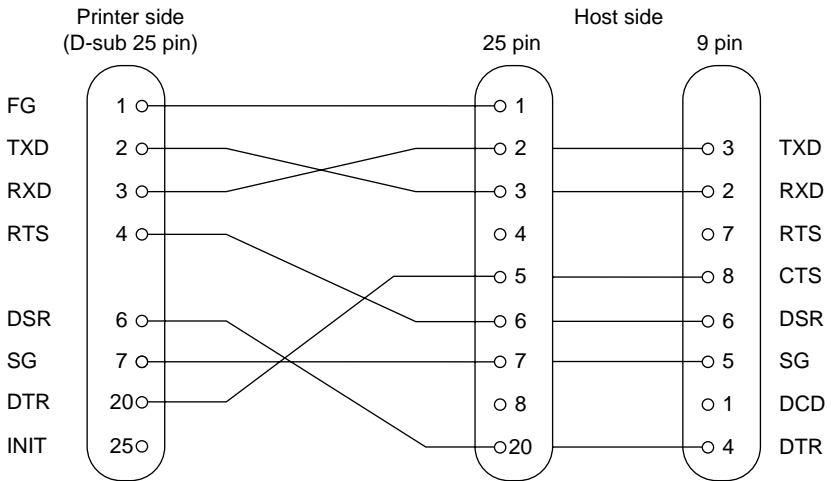

**Note** Use shielded wire less than 3m in length.

## D-3. Electrical Characteristics

Voltage	Data signal	Control signal	Binary status
-3V to -15V	Mark	OFF	1
+3V to +15V	Space	ON	0

# Appendix E: Peripheral Unit Drive Circuit

## Peripheral Drive Connector

Pin No.	Signal name	Function	I/O direction
1	FG	Frame ground	—
2	DRD1	Drive signal 1	OUT
3	+24V	Drive power	OUT
4	+24V	Drive power	OUT
5	DRD2	Drive signal 2	OUT
6	DRSNS	Sense signal	IN

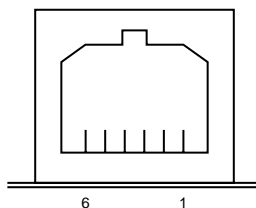

<Viewed from Connector Surface>

## Modular plug

Modular plug: MOLEX 90075-0007,  
AMP641337, or JAPAN BURNDY B-66-4

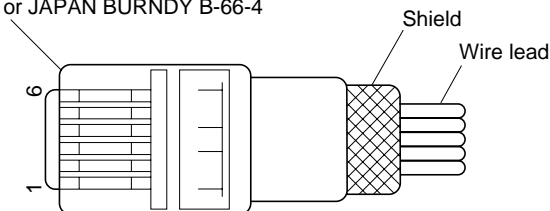

- Notes**
1. A shield cable must be used.
  2. It is not possible to drive two drives simultaneously.
  3. The peripheral drive duty must satisfy the following:  
ON time / (ON time + OFF time)  $\leq$  0.2
  4. The resistance of the peripheral drive solenoid must be 24  $\Omega$  or higher.  
If it is lower than 24  $\Omega$ , over-current may flow into the solenoid, causing the solenoid to burn.



## Appendix F: Memory Switch Settings

Each memory switch is stored in EEPROM. For details on the functions and settings of memory switches, see the separate Programmer's Manual. The table below shows the factory settings for the memory switches.

Memory Switch	Hexadecimal Code
0	0000
1	0000
2	0000
3	0000

### ***Warning!***

Changing the memory switch settings can cause the printer to fail to operate correctly.







**ELECTRONIC PRODUCTS DIVISION  
STAR MICRONICS CO., LTD.**

536 Nanatsushinnya, Shimizu, Shizuoka,  
424-0066 Japan  
Tel: 0543-47-0112, Fax: 0543-48-5013

Please access the following URL  
[http://www.star-micronics.co.jp/service/sp\\_sup\\_e.htm](http://www.star-micronics.co.jp/service/sp_sup_e.htm)  
for the latest revision of the manual.

**OVERSEAS SUBSIDIARY COMPANIES  
STAR MICRONICS AMERICA, INC.**

1150 King Georges Post Road, Edison, NJ 08837-3729 U.S.A.  
Tel: 732-623-5555, Fax: 732-623-5590

**STAR MICRONICS U.K. LTD.**

Star House, Peregrine Business Park, Gomm Road,  
High Wycombe, Bucks, HP13 7DL, U.K.  
Tel: 01494-471111, Fax: 01494-473333