



Operating Instructions

CHARGERY 680B+

Synchronous Rectification and microprocessor controlled high performance rapid Charger/Discharger/Balancer/Monitor for Li-ion, LiPo, LiFe, NiMH/NiCd, and Lead Acid battery packs with cell balancer.

Charge current up to 10A, Discharge current up to 7A

1-6 Li-Ion/LiPo/LiFe, 1-17 NiMh/NiCd, 2-24V lead acid (Pb)



Chargery Power Co., Ltd.

Head Office

Add: Room 20B, Haihui Building, Nanhai Avenue, NanShan, ShenZhen, China

Zip code: 518054

Tel: +86 755 2643 6165

Fax: +86 755 2641 2865

Email: Jasonwang3a@163.com

Web: www.chargery.com

Welcome to the CHARGER 680B+ intelligent balance charger designed especially for 1 to 6 Li-Ion, LiPo and LiFe cells, 1-17 NiMH/NiCd cells and 2 - 24V(1-12) Lead acid(Pb) batteries. Please read the instructions carefully before using the charger.

Special Features

■ **Built-in balancer for Li-Ion, LiPo and LiFe cells**

The CY-680B+ has a built-in individual cell balancer. Li-Ion/LiPo/LiFe batteries are automatically balanced during charging ensuring that when the battery is fully charged it is also properly balanced.

■ **High power and high efficiency circuit**

The CY-680B+ has a maximum output power of 210W with up to 95% power conversion efficiency. The unit can charge or discharge up to 17 Cells of NiMH/NiCd and 1-6S Li-Ion/LiPo/LiFe cells at a maximum current of 10.0A. The automatic thermal management and efficient cooling system ensures that the charger can operate at full power without risk of overheating.

■ **Synchronous Buck-Boost DC/DC converter**

This advanced technology delivers up to 95% power transfer efficiency. This not only conserves power but also enables an especially compact design. Being only 134*83*25(mm) ensures that the charger is easy to take wherever it is needed. The CY-680B+ delivers the full features and power of a high-end charger with the convenience of a field charger.

■ **Dual input power:**

DC jack with auto-resetting fuse (maximal input current 6A) and butt-welded alligator clips with 4mm banana connectors (20A). The output power can be adjusted to align with the available input power. Thus preventing input current overload and protecting the DC source.

■ **Dual confirmation of battery cell count**

In addition to the user manually setting the cell count (displayed as "S"), the CY-680B+ will identify the count automatically (displayed as "R"), and adjust the charging voltage and current automatically through comparing the "S" with "R".

■ **Accept various types of lithium battery**

The CY-680B+ can support three types of lithium batteries -- lithium ion (LiIon), lithium polymer (LiPo) and lithium iron phosphate (LiFe). They have different electrochemical characteristics. You must select the correct chemistry before starting the charge or discharge process. For detailed information, please refer to the "**Warnings and safety abstract**".

■ **Monitor individual cells on Charge/Fast Charge/Discharge/Storage/Cycle/Monitor mode**

The CY-680B+ also can monitor individual cells in the lithium battery pack when you connect the battery to the balance port. If the voltage of any cell varies abnormally, the process will be stopped automatically and an error message displayed.

■ **Unique Monitor mode for discharge with external load**

If the battery needs to be discharged at high current and the target discharge power exceeds the limit of the CY-680B+ you can discharge the battery with an external load such as a lamp, resistor, motor etc. Choose the LI** MONITOR program to monitor and display the cell voltages, battery voltage, battery temperature and discharge time. In the event of any unexpected outcomes the CY-680B+ will alarm and ensure that the cells/battery is not over discharged.

■ **Lithium battery "Fast" and "Storage" mode.**

"Fast" mode reduces the charging time, and the "Storage" mode controls the terminal voltage of the battery to be ready for long term storage.

■ **3 types of balance modes for Balance charge program**

There are 3 modes for terminating balance charges. The cell terminal voltage will be 4.19v in **NORMAL** mode, 4.20V for **SLOW** mode, and 4.18V for **FAST** mode. The trickle current during balance charging can be set. The CY-680B+ will continue to charge at trickle current until the cell voltage reaches 4.18V/4.19V/4.20V, unless the battery is disconnected from the charger when the balance charge finished. The balance trickle can be set ON or OFF.

■ **Customized cell voltage during Cycle mode and Discharge mode**

When you cycle a lithium battery in charge-then-discharge mode or discharge-then-charge mode, you can set the terminal voltage of the charge or discharge. This allows you to charge or discharge a battery pack to any voltage for a special purpose. You can monitor the cell voltages and total charged or discharged capacity (mAh) during the cycle.

A flashing C or D will indicate whether the current cycle process is charge or discharge.

When you discharge the battery, the final voltage can be set up. This is very convenient for special purposes.

■ **Wider charging current range for 50~99900mAh battery**

You can set the charge current from **50 to 10000mA**. This means you can charge batteries down to 50mAh capacity at 1C while the CY-680B+ ensures the current precision and battery safety.

■ **Customized process completion tone**

When any operation completes the beeper will alarm. The CY-680B+ allows you to set the ring to one of 4 modes: Beep 3min/Beep 5times/Beep always (continuous)/Beep OFF

■ **Error message display and inspection**

In the case of an error being detected the LCD will display the possible cause. Press the STOP button return to the main menu, press INC or DEC to check the final information displayed before alarming. Presses START/ENTER to return to the error message screen.

Termination at
112:35 00234mAH

On the bottom line, terminal time and terminal power are displayed

Perfect safety design

Process time limit

You can configure the process run time limit to prevent charge/discharge overrun due to any possible defect.

Battery temperature limit

The battery temperature will rise as a result of internal chemical reactions. The active process will be stopped automatically if the temperature reaches the configured limit.

Internal temperature limit

Internal temperature sensor and temperature controlled automatically cooling fan control the internal temperature and provides intelligent protection. When the internal temperature is over 60°C (140°F), the charging power will be reduced by 25%. If it exceeds 65°C (149°F), the charge will be stopped automatically.

[You can set the temperature units to °C or °F for your convenience.](#)

Capacity charged or discharged limit

The capacity (mAh) is always calculated as the multiple of charge current and time. The charge or discharge process will be stopped automatically if the capacity reaches the configured limit.

Input power monitor

To protect the car battery (or other input power source) from being damaged the input voltage is always monitored. If it drops below the configured limit the active process will be stopped automatically.

When you use an AC adaptor/DC power supply as an input power source, if the input voltage is higher than the configured limit the active process will be stopped to protect the CY-680B+ from being damaged.

Power limit

Maximum charge and discharge power can be configured. The CY-680B+ can charge the battery with up to **99900**mAh capacity. When the unit charges or discharges the battery at 10A for a long time, it can monitor the internal temperature and automatically adjust the charge or discharge power. [The AUTO mode will adjust the charge power according to the input power and internal temperature automatically.](#)

■ Automatic cooling fan:

The electric cooling fan comes into action automatically only when the internal temperature of the unit is over 40°C.

■ Delta-peak sensitivity:

The NiCd/NiMH automatic charge termination program works on the principle of the Delta-peak voltage detection.

■ Auto-charge current limit:

When charging NiCd or NiMH in "AUTO" current mode you can set the upper limit of charge current to avoid exceeding the cells' maximum rated charge current. It is very important when charging small capacity and low impedance NiCd or NiMH battery in "AUTO" mode.

■ **Data store/load:**

For the user's convenience, the CY-680B+ can store up to 10 sets of configuration data. You can store or reload the data at any time. The data contains the user settings and the battery charge/discharge/cycle settings.

■ **Cyclic charging/discharging:**

Perform 1 to 10 cycles of **charge>rest>discharge** or **discharge>rest>charge** continually for battery refreshing, resuming and balancing.

■ **Brightly back-light LCD screen**

The clear backlit LCD shows pack voltage, per-cell voltages, charge current, charge time, capacity charged (mAh), internal and external temperature, input voltage and more.

■ **Light and attractive AL alloy case**

The high-quality aluminum case is light, durable and a very efficient heat sink for cooling the electronics.

■ **Protection function**

- Reverse polarity and short circuit protection (input and output)
- Over-charge and over-current protection
- Detect an over-discharged battery and pre-charge the battery at a low current to restore the battery capacity
- If the LiXX battery voltage is less than 2V per cell the CY-680B+ will refuse to charge to prevent from a potentially dangerous accident.

■ **With Special Connector Conversion Board(CCB-7TPQF,CCB-7N-EH) and conversion wire (CEHP-7X) to fit all kinds of batteries with different balance connectors**

■ **Charge 3*2S, 2*3S battery packs simultaneously. The 3 or 2 packs should be connected to the CCB first and then connect the CCB to the CY-680B+.**

■ **Special designed power supply for CY-680B+**



Warnings and safety abstract

Different electrochemical system rechargeable batteries have different charge and discharge characteristics, and different charging methods.

- Never leave the charger unattended when it is connected to its power supply. If any malfunction is observed immediately stop charging and refer to the instructions.
- Keep the unit away from dust, damp, rain, heat, direct sunshine and vibration. Do not drop it.
- The charger and the battery to be charged or discharged should be placed on a heat-resistant, non-inflammable and non-conductive surface. Never place them on a car seat, carpet or similar.
- Keep all inflammable volatile materials well away from the operating area.
- Be sure to fully understand the specifications of the battery to be charged or discharged. If the battery count is set up incorrectly the battery can be severely damaged and even cause a fire or explosion if overcharged.

NiMh / NiCd

- **Voltage level:** 1.2V/cell
- **Max. charge voltage:** 1.6V/cell
- **Allowable fast charge current:** 1C – 2C depends on the performance of cell
- **Discharge voltage cut off:** 0.85V/cell(NiCd), 1.0V/cell(NiMH)

Li-Ion battery

- **Voltage level:** 3.6V/cell
- **Max. charge voltage:** 4.1V/cell
- **Storage voltage:** 3.75V/cell
- **Allowable fast charge current:** 1C or less
- **Discharge terminal voltage:** 2.5V/cell or higher

LiPo battery

- **Voltage level:** 3.7V/cell
- **Max. charge voltage:** 4.2V/cell
- **Storage voltage:** 3.85V/cell
- **Allowable fast charge current:** 1C or higher
- **Discharge terminal voltage:** 3.0V/cell or higher

LiFe battery

- **Voltage level:** 3.3V/cell
- **Max. charge voltage:** 3.6V/cell
- **Storage voltage:** 3.3V/cell
- **Allowable fast charge current:** 1.5C or higher
- **Discharge terminal voltage:** 2.0V/cell or higher

Lead Acid (VRLA, GEL, and Pb) battery

- **Voltage level:** 2.0V/cell
- **Max. Charge voltage:** 2.46V/cell depends on the application and environment temperature.

- **Allowable fast charge current: 0.5C or less**
- **Discharge terminal voltage: 1.75V/cell or higher**

NOTE:

Be very careful to choose the correct voltage for different of types battery otherwise you may cause damage to the battery. Wrong settings could cause the cells to vent, burn or explode leading to injury or loss of property.

- Do not connect more than one battery pack to the charger output lead at any time unless using the CCB.
- Do not attempt to charge the following types of battery:
 - Battery pack which consists of different types of cell (including different manufacturers).
 - Battery which is already fully charged or just slightly discharged.
 - Non-rechargeable batteries (Explosion hazard).
 - Faulty or damaged battery.
 - Batteries with unconfirmed charging current
- Lithium battery packs can be composed of a mixture of parallel and series circuits. You have to [check the composition of the battery pack carefully before charging](#).
 - Are all connection firm and safe, or is there an intermittent contact at any point in the circuit?

Interface of the CY-680B+



Balance port and Individual Cell connection diagram:

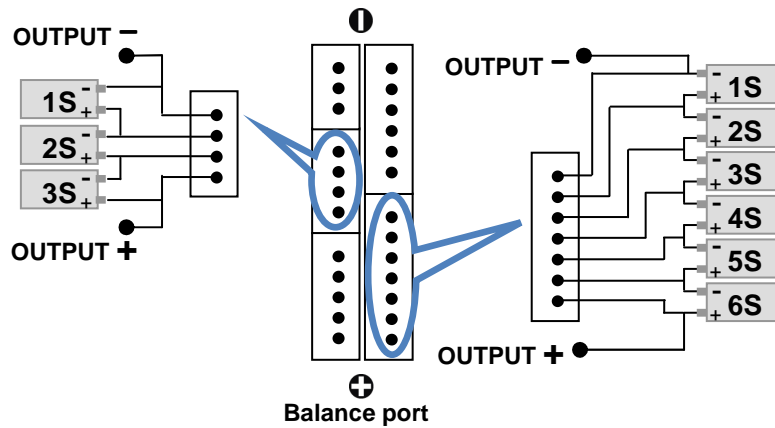

Balance port includes 5 connectors which are connected to 2S, 3S, 4S, 5S or 6S battery with XH balance connectors separately. For Thunder power, Flight power and Polyquest, Hyperion battery, please through adapter board CCB-7TPQF connecting the charger and battery, and the CCB-7N-EH is for the Kokam battery.

NOTE: ONLY ONE BATTERY PLUG INTO THE BALANCE PORT EACH TIME

Testing mode

You can press the **STOP** button for 3 seconds to check all parameters before you conduct any operations; this feature can help you manage the DC power supply, charger User settings (many useful parameters) and the per-cell or battery voltage.

```
Vi11.94V  Int30°C  
Vo 20.23V  Ext25Ω
```

↓ INC/DEC

```
1:4.17  4.18  4.18  
4:4.18  ----  ----
```

On the top line, Input voltage and Internal temperature are displayed
And the bottom line, Output voltage (connected battery voltage) and external temperature are displayed

Single cell voltage is showed, press INC or DEC to check next screen

Resume all parameter defaults

You can press the **STOP** and **START/ENTER** buttons together for 3 seconds to resume all preset parameters before you conduct any operations.

```
Resume Defaults?  
CONFIRM( ENTER)
```

↓ Enter

```
Wait please ...
```

Program flow chart

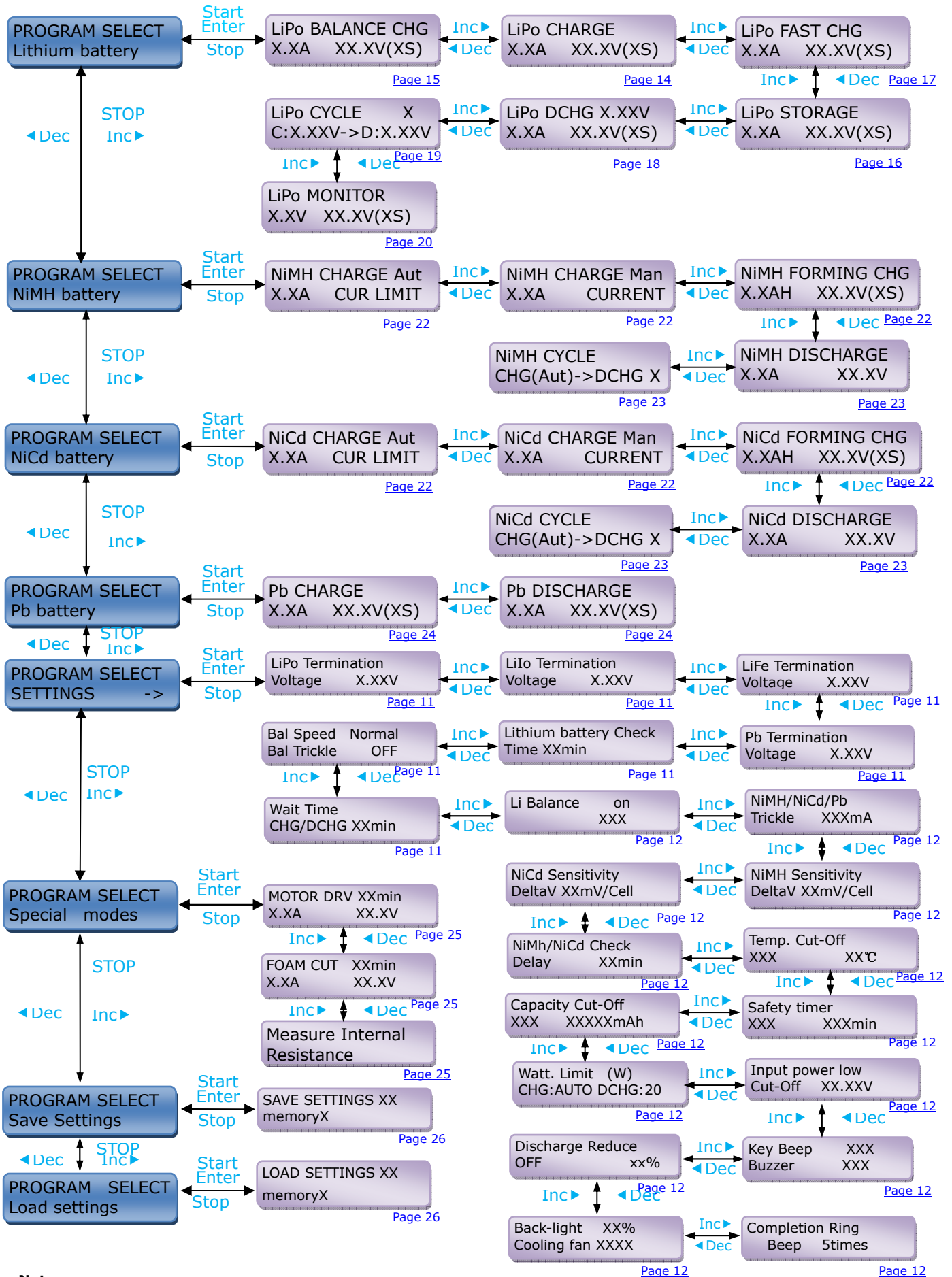

Note:

When you turn off the CY-680B+ it will remember the current menu and start from that menu when next turned on again.

Initial parameter set up

CY-680B+ will be operated with the default values for all User settings when it is connected to a 12V battery or an AC adapter for the first time. The LCD displays the following information in sequence and the user can change the parameter values at each step. When you want to alter a parameter value press the **Start/Enter** button to the value blink then change the value with the **DEC** or **INC** buttons. The new value will be saved by pressing the **Start/Enter** button again.

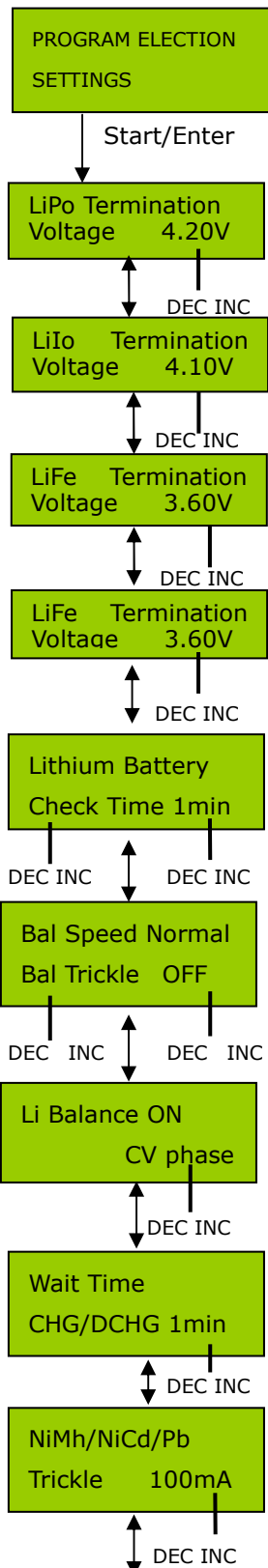

This is the start screen.

The feature function is an advanced setup, Please keep the default setup unless you need charge battery for special purpose.

The program will set up the charge terminal voltage for LiPo/LiIo/LiFe/Pb battery packs. Press Start/Enter button for 3 seconds, make the value flash, and then press DEC or INC button adjust the voltage, press Start/Enter button again to confirm and storage.

LiPo: the voltage range is 4.00V-4.30V, Step:0.01V, Default: 4.20V

LiIo: the voltage range is 3.90V-4.20V, Step:0.01V, Default: 4.10V

LiFe: the voltage range is 3.40V-3.90V, Step:0.01V, Default: 3.60V

Pb: the voltage range is 2.20V-2.50V, Step:0.01V, Default:2.40V

Note: the terminal voltage controls the transition from Constant Current (CC) to Constant Voltage (CV) while charging, It also defines the per cell limit for cell overcharge detection.

If you change the default, the charge and discharge setting screen will note this difference by alternatively blinking battery's type and setting voltage value.

The 680B+ identifies the cell count of lithium batteries automatically. Normally, 10 minutes of check time are enough to perceive the cell count correctly, the check time depends on the state of the charge of battery. If the charger identifies the cell count incorrectly at the beginning of the charge or discharge process, you may extend the time. Otherwise, you should use the default value. **Range: 1-10min. (1min, default)**

There are 3 Balance speed settings. "FAST" will ensure the cell termination voltage higher and shorter charging time, "SLOW" will let the cell termination voltage lower, and "NORMAL" assure the voltage between the SLOW and Fast mode. (Normal, default)

"Bal trickle" sets the trickle charge mode on or off. ON means to continue to charge till the charging current falls to around 20mA (OFF, default)

As to the lithium battery balance process. There are 3 points to start the process. **CV phase** means when any cell voltage reaches the set voltage for CV, the charger will start to balance process. **STORAGE VOLTAGE** is start balance when any cell voltage reaches the default storage voltage for the configured chemistry, **ALWAYS** is start at the beginning of the charge. **(CV voltage, default)**

The battery can often be warm after charge or discharge. The program can set up an idle time to allow the battery to cool down before being subjected to the next process (charge or discharge). The time value ranges from 1 to 60 minutes, 10min default.

For the NiMh / NiCd / Pb battery charge mode you can set the trickle charge current or turn it off. If it is on, the charger will automatically supply the trickle charge current to achieve the full charge without overheating the battery after fast charge has been terminated. The current value ranges from 10mA to 500mA. The default is OFF.



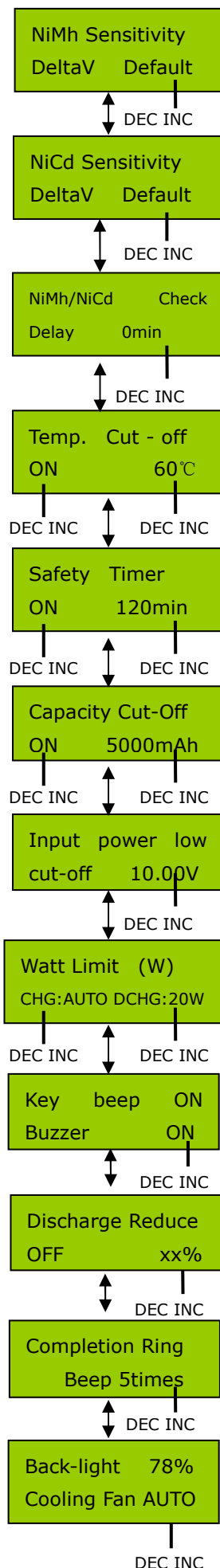

This menu shows the trigger voltage for automatic charge termination of NiMH and NiCd batteries. The effective value ranges from 1-20mv per cell. If the trigger voltage is set higher, there is a danger of overcharging the battery; if it is set lower, there is a possibility of premature termination. Please refer to the technical specification of the battery. **(NiCd default: 8mv, NiMH default: 4mv)**

When NiMh & NiCd batteries are deeply discharged or left unused for a long time, they will produce a false -ΔV which stops charging early, you can disable -ΔV testing to avoid this problem . Range:0-30min, (0, default)

To use temperature probe monitor battery temperature. The feature can be on or off. If it is on, set the maximum temperature the charger can allow the battery to reach during charging. If the battery temperature reaches the limit the charging will be ended to protect the battery. The temperature range is **20-80°C or 68-176 °F. °F=(9/5)* °C+32**

You can set the temperature unit to °C or °F.

When you start a charge process, the integral safety timer automatically starts running. This is programmed to prevent overcharge of the battery if it proves to be faulty or if the termination circuit cannot detect the battery becoming fully charged. The value should be generous enough to allow a full charge of the battery. The range is **0- 999min**

This menu sets the maximum charge or discharge capacity during charge or discharge. If the termination circuit cannot detect the battery fully charged or discharge termination, this feature will automatically stop charging or discharging at the set capacity value. The capacity range is **100- 9990mAh.**

The charger monitors the voltage of the input power source. If the voltage drops below the value you set the charging process will be stopped automatically to protect it. **Range: 10.00-15.00V (10.00V, default)**

The charger monitors the charge power and discharge power. You can set the value to acquire the best result and highest efficiency. The maximum charge power is 210W and the maximum discharge power is 20W. AUTO mode for charge power will adjust the charge power according to the input power or internal temperature automatically. This protects the input power from overloading or the charger over temperature.

CHG:50-210W, and AUTO, DCHG:5-20W.

The beep sounds for each button press to confirm your action. A beep or melody sounds at various times during operation to alert the user to mode changes. These sounds can be on or off.

Discharge Reduce setting, when you set it "ON", If the final voltage target storage voltage is reached, the buzzer will beep for 3 times, and the left of the second line display "D>>", and the charger enter into the high accuracy discharge process until the current reaches XX% of the configured discharge current. **Reduce: ON, OFF, Range:1-99%**

This menu sets the beeper mode for the alarm that sounds after the active process completes. **Options: Beep 5 times, beep for 3min, Beep always (continuous until the user presses STOP), or Beep OFF. (Beep always, default)**

This menu sets the brightness of LCD screen backlight.

The Cooling fan has 3 modes, ON, OFF and AUTO. In AUTO mode it is intelligently controlled to start as needed based upon the internal temperature.

Lithium battery (LiIo/LiPo/LiFe) programs

These programs are only suitable for charging Lithium batteries with a nominal voltage of 3.6V/cell (lithium ion cell), 3.7V/cell (Lithium polymer cell) and 3.3V/cell (LiFePO4). This type of battery is charged using a constant current (CC) then constant voltage (CV) profile. The charge current is dependent on the battery capacity. Generally the charge current is less than 1C (the C is battery capacity, for example, if the capacity is 3000mAh, the charge current is less than 3000mA). The terminal voltage when full charged is very important, the charge current and nominal voltage for the configured cell count must always be correct for the battery to be charged.

Before charging you must set the Lithium type LiIo (3.6V), LiPo (3.7V) or LiFe (3.3V).

When you want to alter the parameter values, press the **START/ENTER** button to make it blink then change the value with **DEC** or **INC**. The new value will be saved by pressing **START/ENTER** once again.

CY-680B+ provides 7 types of program including Charge, Fast charge, Balance charge, Discharge, Storage, Cycle and Monitor. Only Balance charge program requires the balance leads connected. However, the other programs will provide additional per-cell over-voltage protection if the balance leads is connected compared to running them without it, where they can only utilize the total pack voltage.

program		Balance connector required	Balancer active	Charge terminal condition
Charge		optional	NO	$I_{cv} = I_{cc}/10$
Fast charge		optional	NO	$I_{cv} = I_{cc}/5$
Balance charge	Normal	YES	YES	$I_{cv} = I_{cc}/10$
	Fast	YES	YES	$I_{cv} = I_{cc}/5$
	Slow	YES	YES	$I_{cv} = I_{cc}/40$
Storage		optional	NO	$V_t = \text{cell count} * \text{storage voltage per cell}$
Cycle	charge	optional	NO	$I_{cv} = I_{cc}/10$
	discharge	optional	NO	$V_t = \text{cell count} * \text{discharge terminal voltage per cell}$

I_{cc} is configured charge current for the constant current (CC) phase

I_{cv} is charge current for the constant voltage (CV) phase

V_t is the total pack voltage

- Any time CY-680B+ will monitor and display each cell voltage on condition that the balance leads is connected
- The built-in cell balance will be activated only on balance charge program
- The **balance speed setting** (slow, normal, fast) controls the end of charge current threshold.
- The CHARGE and FAST CHARGE program is identical except the charge terminal threshold
- While CHARGE and FAST CHARGE program, the battery is still safer even the balancer is not activated, because the charger will monitor each cell voltage when the balance connector is connected.

Charge Lithium battery in CHARGE mode

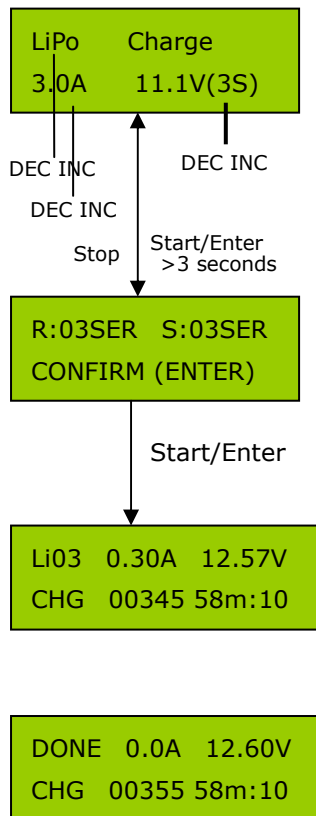

On the left side of the first line, You can set up the type of battery (LiPo, LiIo, and LiFe). The values on the second line set the charge current and the voltage (cell count) of the battery pack. Press **START/ENTER** to make the value flash then press **DEC** or **INC** to adjust the value. After setting the current and voltage press **START/ENTER** again for more than 3 seconds to start the process. (Charge current: 0.05~10.0A, Voltage: 1~6 series)

This screen shows the cell count. 'S' is the value set up by you at the previous screen and 'R' shows the cell count detected by the charger. If both counts are identical you can start charging by pressing **START/ENTER**. If not, press **STOP** to go back to the previous screen. Then carefully check the battery nominal voltage to charge again.

This screen shows the status during charging. **Li3S means the battery pack is being charged as 3 cells in series even the cell count you selected is not 3. Li03 and li × × are displayed in turn. It indicates the battery type and cell count.** On the top line it shows cell count, charging current and battery voltage from left to right. While the bottom line shows Charge (CHG), capacity charged (mAh) and charging time.

To stop the charge, press **STOP**.

The battery is fully charged.

If the battery is connected to the balance port, you can monitor the voltage of individual cells by pressing **INC** during the process.

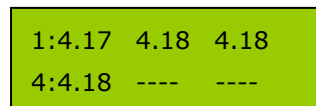

The first line shows the voltages of cells 1, 2 and 3 from the left. The second line shows the voltages of cells 4, 5 and 6.

You can also check the parameters you configured in the USER SET PROGRAM by pressing **DEC**. This includes end voltage, safety timer, capacity limit, temperature limit, external and internal temperature, and input voltage limit.

Charge Lithium battery in BALANCE CHARGE mode

This is for balancing the cell voltages of the battery pack to be charged. To do this, the battery pack should have the balance leads connected to the balance port at the right side of charger. At the same time, the battery power leads should be connected to the output of the charger.

In this mode, the charging process will be different from ordinary charging mode. The built-in balancer will monitor the voltage of each cell of the battery pack and adjust the charge current feeding to each cell to balance the voltage.

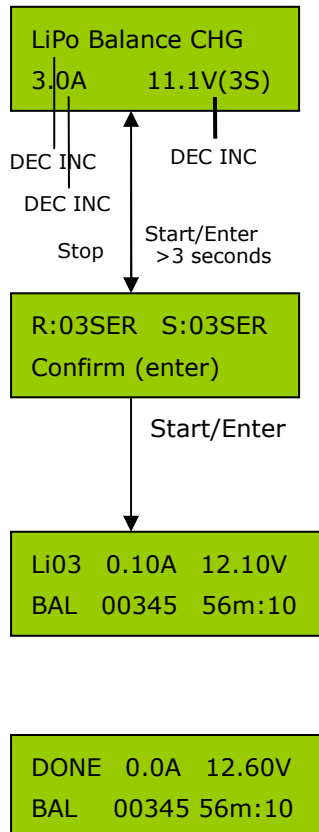

On the left side of the first line, You can set up the type of battery (LiPo, LiIo, LiFe). The values on the second line set the charge current and the voltage (cell count) of the battery pack. Press **START/ENTER** to make the value flash then press **DEC** or **INC** to adjust the value. After setting the current and voltage press **START/ENTER** again for more than 3 seconds to start the process. (Charge current: 0.05~10.0A, Voltage: 1~6 series)

This screen shows the cell count. 'S' is the value set by you at the previous screen and 'R' shows the cell count detected by the charger. If both counts are identical you can start charging by pressing **START/ENTER**. If not, press **STOP** to go back to the previous screen. Then carefully check the battery nominal voltage to charge again.

The screen shows the status during the charge process. **Li03 means the battery pack charged is 3 cells in series even if the cell count you selected is not 3. Li03 and LiX X are displayed in turn. It indicates battery type and cell count.** On the top line, it shows cell count, charging current and battery voltage from left to right. While the bottom line shows Balance Charge (BAL), capacity charged (mAh) and charging time. To stop the charge, press **STOP**.

The battery is fully charged and balanced.

You can monitor the voltage of individual cells by pressing **INC** during the process.

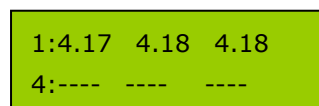

The first line shows the voltages of cells 1, 2 and 3 from the left. The second line shows the voltages of cells 4, 5 and 6.

You can also check the parameters you configured in the USER SET PROGRAM by pressing **DEC**. This includes end voltage, safety timer, capacity limit, temperature limit, external and internal temperature, and input voltage limit.

Lithium battery (LiIo/LiPo/LiFe) in STORAGE (charge/discharge) mode

This is for storage of the pack to be charged or discharged. To do this, the battery pack should connect to the DC OUT, the unit will determine to charge or discharge the battery pack to the certain voltage depending on the initial voltage of the battery. The storage voltage depends on the type of the battery: 3.75V/cell for LiIo, 3.85V/cell for LiPo and 3.3V/cell for LiFe.

If the battery pack is also connected to the balance port the charger will monitor the cell voltages.

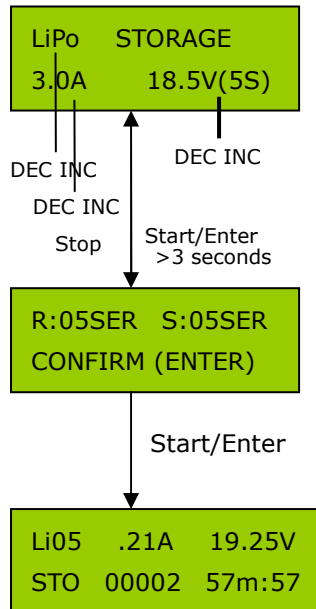

On the left side of the first line, you can set up the type of battery (LiPo, LiIo, LiFe). You can set the current and the voltage of the battery pack to be charged or discharged. The current will be used for charging or discharging the battery to reach the "storage" voltage. (Charge current: 0.05~10.0A, Voltage: 1~6 series)

This screen shows the cell count. 'S' is the value set by you at the previous screen and 'R' shows the cell count detected by the charger. If both counts are identical you can start the process by pressing **START/ENTER**. If not, press **STOP** to go back to the previous screen. Then carefully check the battery nominal voltage to do again.

This screen shows the status during the process. **Li05 means the battery pack is 5 cells in series. Li05 and LiXX are displayed in turn. It indicates battery type and cell count.** On the top line, it shows cell count, charge/discharge current and battery voltage from left to right. On the bottom line it shows Storage (STO), capacity charged or discharged (mAh) and process time.

To stop the process, press **STOP**.

Note: during discharging a Lithium battery process, on the left of the bottom line alternately display "STO/DSC", if the target storage voltage is reached, the buzzer will beep for three times, and on the left of the bottom line alternately display "STO/D>>", and then start the high precision discharge process till the current reach 1/10 of the configured discharge current.

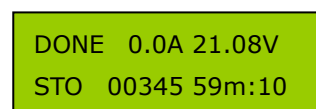

The battery is in storage status.

If the battery is connected to the balance port you can monitor the voltage of individual cells by pressing **INC** during the process.

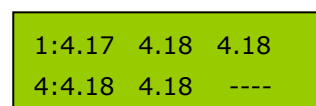

The first line shows the voltages of cells 1, 2 and 3 from the left. The second line shows the voltages of cells 4, 5 and 6.

You can also check the parameters you configured in the USER SET PROGRAM by pressing **DEC**. This includes end voltage, safety timer, capacity limit, temperature limit, external and internal temperature, and input voltage limit.

Charge Lithium battery in FAST CHARGE mode

The charging current is reduced as the CV phase progresses. If the terminating charge current is bigger than for normal charging the charging process will end sooner. The capacity charged may be a bit smaller than normal charging but the process time will be reduced. If the battery pack is also connected to the balance port then the charger will monitor the cell voltages.

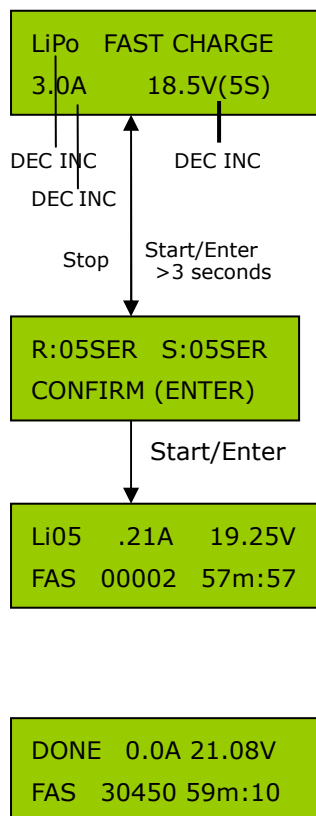

On the left side of the first line, You can set up the type of battery (LiPo, LiIo, LiFe). The values on the second line set the charge current and the voltage (cell count) of the battery pack. Press **START/ENTER** to make the value flash then press **DEC** or **INC** to adjust the value. After setting the current and voltage press **START/ENTER** again for more than 3 seconds to start the process. (Charge current: 0.05~10.0A, Voltage: 1~6 series)

This screen shows the cell count. 'S' is the value set by you at the previous screen and 'R' shows the cell count detected by the charger. If both counts are identical you can start charging by pressing **START/ENTER**. If not, press **STOP** to go back to the previous screen. Then carefully check the battery nominal voltage to charge again.

This screen shows the status during the process. **Li05 means the battery pack is 5 cells in series even if the cell count you set is not 5. Li05 and Li×× are displayed in turn. It indicates battery type and cell count.** On the top line, it shows cell count, charge/discharge current and battery voltage from left to right. On the bottom line it shows Storage (STO), capacity charged or discharged (mAh) and process time.

To stop the process, press **STOP**.

The Fast charge process is DONE.

If the battery is connected to the balance port you can monitor the voltage of individual cells by pressing **INC** during the process.

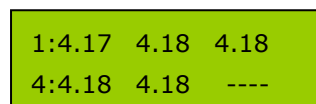

The first line shows the voltages of cells 1, 2 and 3 from the left. The second line shows the voltages of cells 4, 5 and 6..

You can also check the parameters you configured in the USER SET PROGRAM by pressing **DEC**. This includes end voltage, safety timer, capacity limit, temperature limit, external and internal temperature, and input voltage limit.

Discharge Lithium battery in DISCHARGE mode

To discharge Lithium battery connects the pack the charger's DC OUT terminals. The charger will discharge the battery pack to the terminal voltage. If the battery pack is connected to the balance port the charger will monitor the cell voltages.

The terminal voltage depends on the battery type. Please refer **"Warnings and safety abstract"**.

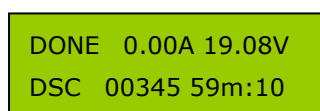
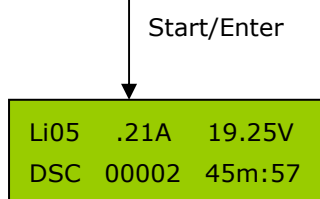
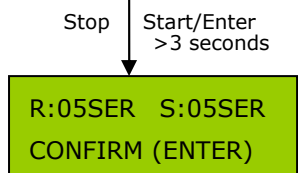
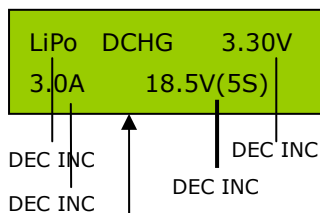

On the left side of the top line, You can set the type of battery (LiPo, LiIo, LiFe). On the right, the terminal voltage per cell can be set up, so you can discharge the battery to any voltage you want for a special purpose.

The value on the second line sets a discharge current and the cell count.

Press **START/ENTER** to make the value flash then press **DEC** or **INC** to adjust the value. After setting the current and voltage press **START/ENTER** again for more than 3 seconds to start the process. (Discharge current: 0.05~7.0A, Voltage: 1~6 series)

This screen shows the cell count. 'S' is the value set by you at the previous screen and 'R' shows the cell count detected by the charger. If both counts are identical you can start discharging by pressing **START/ENTER**. If not, press **STOP** to go back to the previous screen. Then carefully check the battery nominal voltage to discharge again.

This screen shows the status during the process. **Li05 means the battery pack is 5 cells in series even if the cell count you set is not 5. Li05 and Li×× are displayed in turn. It indicates battery type and cell count.** On the top line, it shows cell count, discharge current and battery voltage from left to right. On the bottom line it shows Discharge (DSC), capacity discharged (mAh) and process time.

During the process, your can press **ENTER** to make current blink and then press **INC** or **DEC** to change the discharge current then press **ENTER** again to store the new value.

To stop the process, press **STOP**.

The discharging process is DONE.

If the battery is connected to the balance port at the beginning of discharge, the charger will monitor the voltage of individual cells, when each cell's voltage reaches the terminal voltage, the process will stop forcibly and display "balance port low cell vol".

If the battery do not connect to the balance port or connect after the discharge started. The charger will not monitor the cell voltage but only monitor the pack voltage, and when the battery pack voltage reaches the terminal voltage, the process will be stopped.

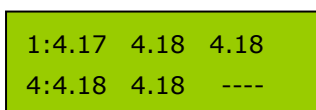

The first line shows the voltages of cells 1, 2 and 3 from the left. The second line shows the voltages of cells 4, 5 and 6.

You can also check the parameters you configured in the USER SET PROGRAM by pressing **DEC**. This includes end voltage, safety timer, capacity limit, temperature limit, external and internal temperature, and input voltage limit.

Lithium battery (LiIo/LiPo/LiFe) in CYCLE mode (charge to discharge, discharge to charge)

This program is to refresh or restore the battery capacity. There are 2 modes, charge-then-discharge and discharge-then-charge. To do this connects the pack the charger's DC OUT terminals. If the battery pack is connected to the balance port the charger will monitor the cell voltages.

You need set the wait time between charge and discharge to cool down the battery.

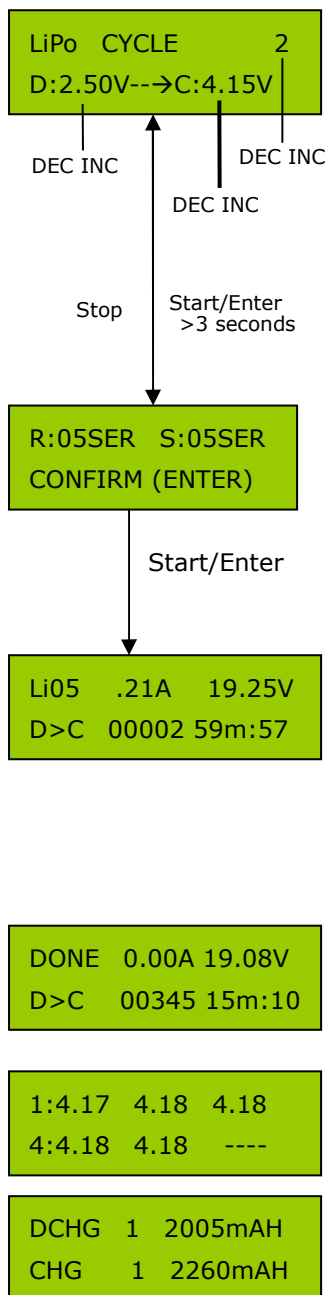

On the left side of the top line, You can set the type of battery (LiPo, LiIo, LiFe). and the number of cycles can be set on the right. The values on the second line set the cycle sequence and **terminal voltage** when charging or discharging. The terminal voltage is per cell which allows you to charge or discharge the battery pack to any voltage.

Press **START/ENTER** then press **DEC** or **INC** to change the value. After setting press **START/ENTER** for more than 3 seconds to start the process. You can use this function for balancing, refreshing and breaking-in a battery. To avoid over-heating the battery there will be a brief cool-off period that set up at 'SETTING PROGRAM'.

The cycle number is from **1 to 10**.

This screen shows the cell count. 'S' is the value set by you at the previous screen and 'R' shows the cell count detected by the charger. If both counts are identical you can start Charging by pressing **START/ENTER**. If not, press **STOP** to go back to the previous screen. Then carefully check the battery nominal voltage to cycle again.

This screen shows the status during the process. **Li05 means the battery pack is 5 cells in series even if the cell count you set is not 5. Li05 and Li x x are displayed in turn. It indicates battery type and cell count.** On the top line, it shows cell count, current and battery voltage from left to right. On the bottom line it shows the cycle mode (C>D or D>C), capacity charged or discharged (mAh) and cycle time. **The flashing C or D indicates the current process---charge or discharge.** The Charging current is accordance with the current set up in the "LI** CHARGE", and the discharging current is as same as the current set up in the "LI** discharge".

The Cycle process is DONE.

During the process, press **INC** to see the capacity charged or discharged at each cycle process. if you connect the battery to the balance port, you can monitor the cell voltages at the same time

You can also check the parameters you configured in the USER SET PROGRAM by pressing **DEC**. This includes end voltage, safety timer, capacity limit, temperature limit, external and internal temperature, and input voltage limit.

MONITOR Lithium cell (LiIo/LiPo/LiFe) voltage when discharging with external loads

The program is to monitor the cell voltages and alarm when the battery is discharged with external loads. This function will protect any cell from being over discharged. You can use any loads such as lamps, resistors or others and not worry that any cell or the battery overall will be over discharged.

To do this, you must connect the battery to the balance port on the charger, at the same time, the battery discharge leads must be connected to the DC out port of the charger and to the external load. The connection diagram is as below (using a 3S battery as an example).

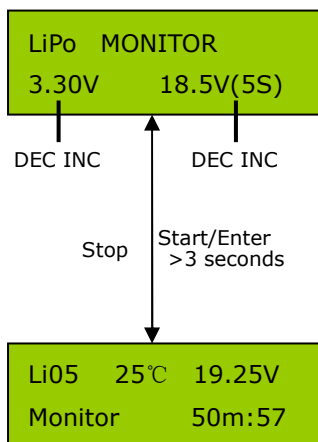
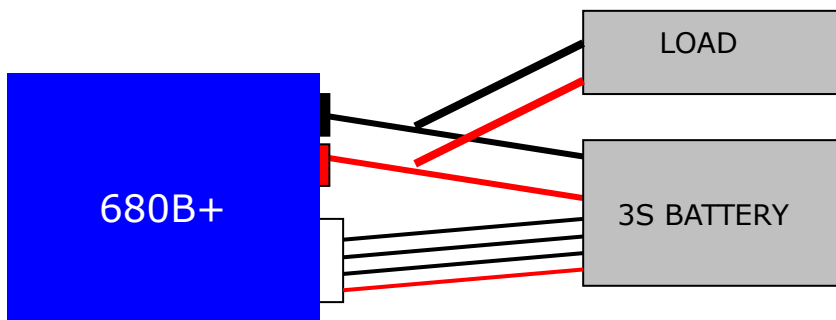

On the left side of the top line, You can set the type of battery (LiPo, LiIo, LiFe). On the second line, the cell count and the minimum cell voltage can be set. the program will monitor each cell voltage when the battery pack is discharged with external loads. The cell voltage is 3.0 to 4.2V for LiPo, 2.5 to 4.1V for LiIo, and 2.0 to 3.6V for LiFe battery. The cell count is 1 to 10S.

The screen shows the status during discharge. **Li05 and liX X are displayed in turn. It indicates battery type and cell count.** On the top line battery temperature and battery voltage are shown from left to right. On the bottom line the monitoring time is shown.

If you press **STOP** the charger will stop monitoring the cell voltages.

When you disconnect the battery and loads the charger continues to monitor the battery state, if you continue to discharge, please press **START** to monitor again.

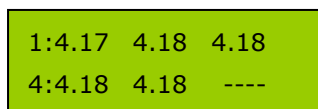

During the process, press **INC** or **DEC** to see the cell voltages. When any cell is over discharged, the charger will alarm.

During the process, when the battery temperature, battery voltage, cell voltage or the process time reaches the configured limit, the charger will alarm.

Pre-charge a lithium battery pack

If the battery pack is over discharged, when using the CHARGE or Fast CHARGE modes, CY-680B+ will pre-charge the battery at a low current. This will increase the voltage to an allowable range. The pre-charge time can be set in the Lithium Check time in the USER SETUP.

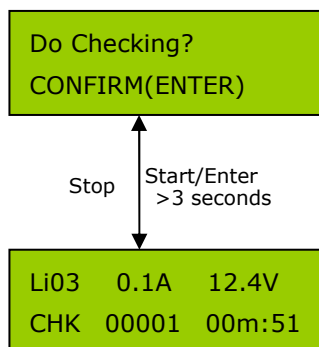

The left screen is displayed when the charger detects the battery voltage in the CHARGE or FAST CHARGE mode.

To Pre-charge lithium battery, Press **START/ENTER** button to start the charging process or press **STOP** button to return the previous screen.

Checking process is displayed.

The left of the first line shows the type of battery (LiPo, LiIo, LiFe) and number of cells detected. The top line shows the pre-charging current and battery voltage

On the bottom line, charge time and capacity charged is displayed. When the time reaches the limit, the charger will charge at the set current. You can stop the pre-charge process at any time by pressing the **STOP** button.

NiMh/NiCd battery program

These programs are for charging or discharging NiMH (Nickel-Metal-Hydride) or NiCd (Nickel-Cadmium) batteries commonly used for R/C model applications.

To alter the displayed value press the START/ENTER button to make it blink then change the value using the INC and DEC buttons. Store the new value by pressing the START/ENTER button again.

To start the process press the START/ENTER button for more than 3 seconds.

NiMh/NiCd charging in **Automatic** mode

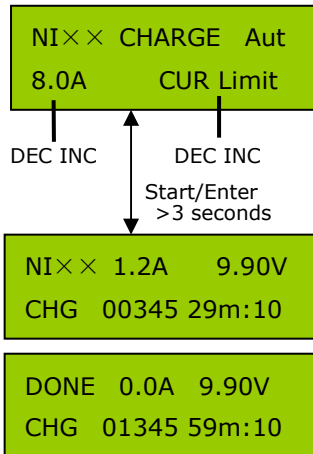

In the "Aut" mode the 680B+ charges the battery at about 1C but at no more than the maximum current you set on the second line.
(Charge current range: 0.05~10.0A)

The screen shows the status during charging. To stop the charge press **STOP**. The top line shows the charging current and battery voltage from left to right. On the bottom line it shows Charge (CHG), capacity charged (mAh) and charging time.

When the process is DONE the process completion tone is sounded.

NiMh/NiCd charging in **Manual** mode

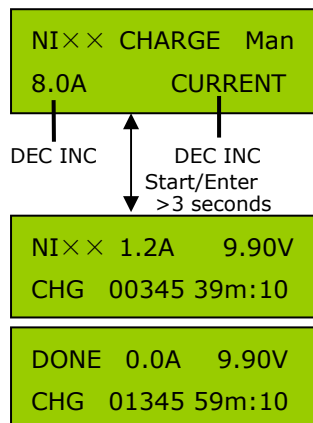

In "Man" mode the 680B+ charges the battery using the current you set on the second line.
(Charge current: 0.05~10.0A)

The screen shows the status during charging. To stop the charge press **STOP**. The top line shows the charging current and battery voltage from left to right. On the bottom line it shows Charge (CHG), capacity charged (mAh) and charging time.

When the process is DONE the process completion tone is sounded.

NiMh/NiCd charging in **Forming** mode

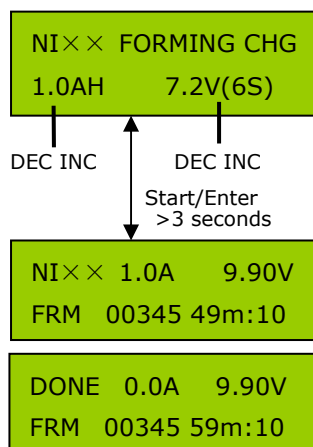

In "Forming" mode the 680B+ charges the battery at up to 1C at CC/CV mode. The function is very useful for unbalanced battery pack. Forming charge will recover battery balance status.

The battery capacity and cell count can be set. The capacity range is 0.1-9.9AH, the cell count is 1-17S.

The screen shows the status during Forming. To stop the charge press **STOP**.

The top line shows the charging current and battery voltage from left to right. On the bottom line it shows FORMING (FRM), capacity charged (mAh) and charging time.

You can press the START/ENTER button to reset the forming current. Press the button again confirmed.

When the forming charge is done. The process completion tone is sounded.

NiMh/NiCd battery **Discharge** mode

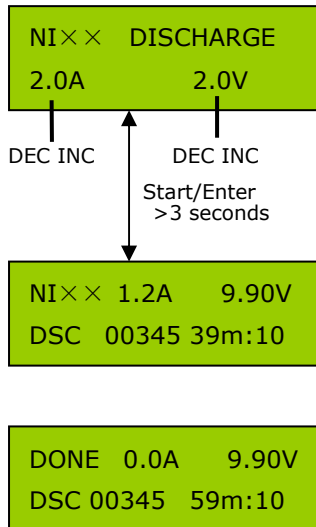

The value on the second line sets the discharge current and the terminal voltage of the battery pack.

Discharge current is from 0.05~7.0A, the terminal Voltage is from 0.1~29V

The screen shows the status during discharging. To stop the discharge press **STOP**. The top line shows the discharging current and battery voltage from left to right. On the bottom line it shows Discharge (DSC), capacity discharged (mAh) and discharging time.

During the process your can press **ENTER** to make current blink and then press **INC** or **DEC** to change the discharge current. Press **ENTER** again to confirm.

When the process is DONE the process completion tone is sounded.

NiMh/NiCd battery **Cycle** mode

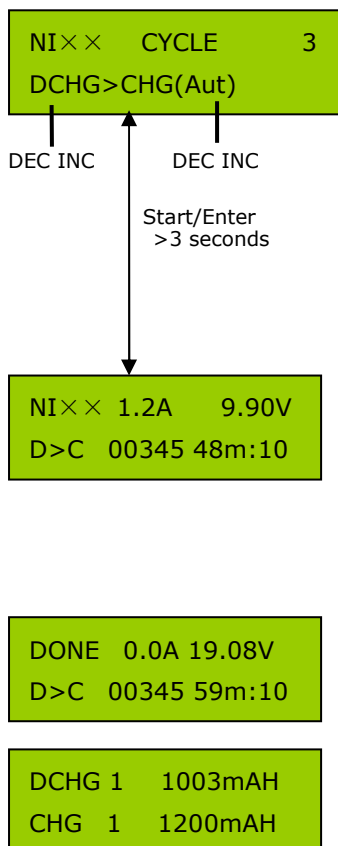

Set the charge and discharge sequence on the left and the number of cycles on the right. Set the charge current in the Charge Man or Charge Aut mode menu and the discharge current in the DISCHARGE mode menu.

You can use this function for breaking-in, balancing or refreshing the battery. To avoid overheating the battery there will be a brief cool-off period after each charge/discharge phase. The Wait time is set in the 'USER SET PROGRAM' menu.

The cycle number is from **1 to 10**.

The screen shows the status during cycling process. The top line shows current and battery voltage from left to right. The bottom line shows the cycle mode (C>D or D>C), capacity charged or discharged (mAh) and cycle time. **The flashing C or D indicates the current process: charge or discharge.** You set the Charging current in the "NI** CHARGE Man" or "NI ** CHARGE Aut" menu and the discharging current in the "NI** DISCHARGE " menu.

To stop the process, press **STOP** button.

The Cycle process is DONE.

During the process, press **INC** to see the charged or discharged capacity of the battery at each cycle process.

Lead acid (Pb) battery **CHARGE** mode

This program is for charging Pb (lead-acid) batteries with nominal voltages from 2 to 36V. Lead acid battery or VRLA, Gel batteries are totally different from NiCd or NiMH batteries. They can only deliver relatively lower current compared to their capacity and charging can only be done at relatively low rates compared to other chemistries. The optimal charge current is 0.1C. This type of battery must not be charged rapidly. Always follow the instructions supplied by the battery manufacturer.

To alter a parameter value, press START/ENTER to make it blink then change the value with INC or DEC. Store the value by pressing START/ENTER key again.

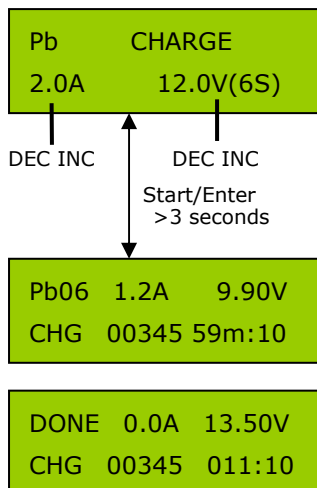

Set the charge current and the nominal voltage of the battery. The charge current range is 0.05~10.0A and should be set to 0.1C for the battery to be charged. The voltage should be matched to the nominal voltage of the battery to be charged. The voltage parameter range is 2-24V(1-12S).

The screen shows the status during the charge process. The top line shows the cell count, charging current and battery voltage from left to right. The bottom line shows Charge (CHG), capacity charged (mAh) and charging time.

To stop the charge, press **STOP**.

When the process is DONE the process completion tone is sounded.

Note: 680B+ support Pb (lead-acid) floating charge. First you should start the setting of "Trickle ON" in "NiMH/NiCd/Pb Trickle". It will floating charge when the battery voltage is larger than 2.25V/CELL.

Lead acid (Pb) battery **DISCHARGE** mode

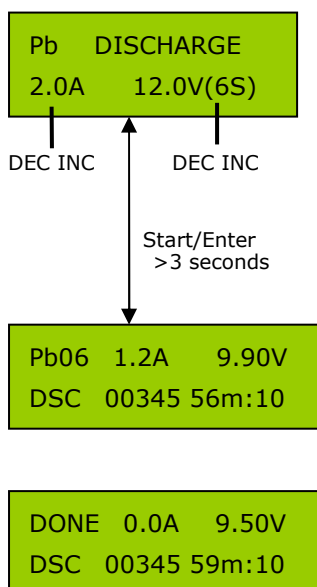

Set the discharge current and the nominal voltage of the battery. The discharge current ranges from 0.05 to 7.0A. The voltage should be matched to the nominal voltage of the battery to be discharged. The nominal voltage range is 2-24V.

The screen shows the status during discharge process.

The top line shows the cell count, discharging current and battery voltage from left to right. The bottom line shows discharge (DSC), capacity discharged (mAh) and discharging time.

During the process, you can press **ENTER** to make the current blink and then press **INC** or **DEC** to change the value. Press **ENTER** once again to confirm.

To stop the discharge press **STOP**.

When the process is DONE the process completion tone is sounded.

Special mode program

Electric Motor Drive

You can easily break-in new **brushed** electric motors with a variable voltage and running time.

Note that brushless motors do not require or benefit from a breaking-in process.

With this program you can also check the motor output power to optimize your power train set up. The break-in process is essential for maximizing the power of a new brushed motor. New motors have square brushes which press up against the curved commutator. The goal of the break-in process is to gently shape the brushes so that they develop a curved surface that fits snugly against the commutator giving a greater conducting surface area and hence lower losses and higher efficiency.

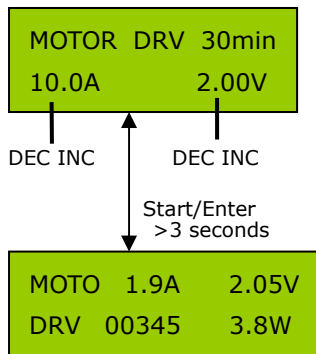

Connect the motor to the DC OUT. Set up the testing time, maximum current limit and the drive voltage. To start the motor run press **START/ENTER** for more than 3 seconds. (Time is 1 to 90min, limit current is 0.05-10A, Test voltage is 1-15V.)

The screen shows the status during the motor run process.

The top line shows the operating current and driving voltage from left to right. The bottom line shows the consumption capacity (mAh), output power or time.

To stop the process, press **STOP** once.

Foam Cut Drive

In this mode, the Foam Cut program can provide you as a convenient power supply for the hot wire.

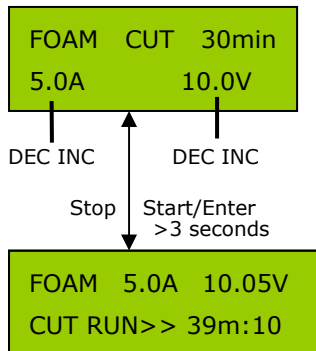

Connect the foam cutter to the DC OUT. Set up the running time, maximum current limit and the voltage. To start the foam cutter, press **START/ENTER** for more than 3 seconds. (Time is 1 to 90min, limit current is 0.05-10A, voltage is 1-25V.)

The screen shows the status during the foam cut running process.

The top line shows the operating current and voltage from left to right. The bottom line shows the output power or total running time.

To stop the process, press **STOP** once. Press **START/ENTER** once, stop temporarily.

Connection diagram

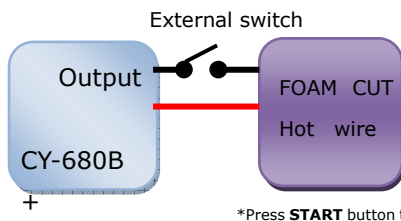

work statement diagram

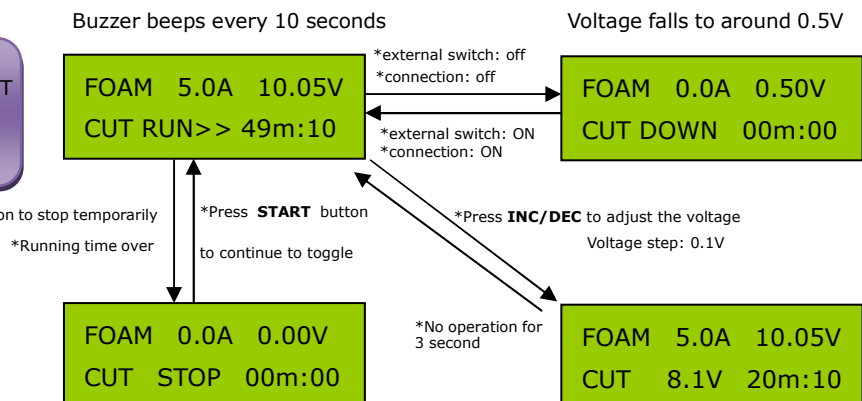

Measuring impedance of the lithium battery pack

In generally, the impedance of battery is not a fixed value, it varies over time as the battery loses energy and also varies depending on the load. Or how much current is drawn from the battery. One of the urgent requirements of battery is low internal impedance. Measured in milliohms, the impedance is the gatekeeper that, to a large extent, determines the runtime. The lower the impedance, the less restriction the battery encounters in delivering the needed power spikes.

680B+ can measure the impedance of battery pack.

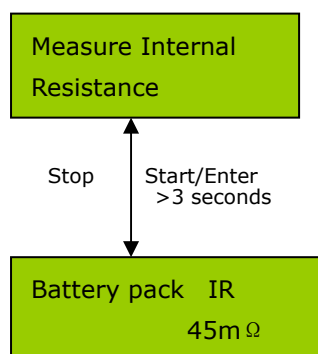

you can press **START/ENTER** for more than 3 seconds to start the process and stop at any time by **STOP**.

This screen displays the battery pack impedance. Press START/ENTER to measure it again. And press STOP return to main menu.

Data Save settings

The CY-680B+ has a settings storage and load program for your convenience. This feature can store up to 10 datasets by number. Each dataset represents the individual setup for a particular set of batteries. Datasets can be reloaded for charging or discharging without having to reconfigure all the parameters again.

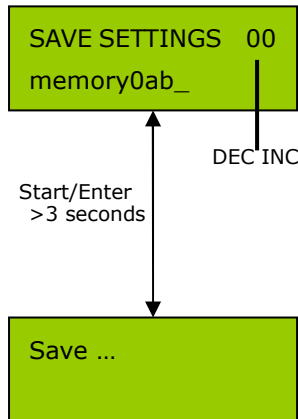

The number "00" on the top line refer to the target memory number which to store the dataset. On the bottom line, the "memory0_" refer to the character which you want to input. Press **INC** or **DEC** button to walk letters, and then press **START/ENTER** button to confirm and move to next position. When finishing the input, press **START/ENTER** button twice to confirm. Press **STOP** button to delete the wrong character. Hold **START/ENTER** than 3 seconds to save the currently data to the name just input. Press **STOP** to exit without saving any changes. (Memory locations are in the range of 00 ~ 09).

The screen shows the charger is storing all of current data into the specified memory location. When the process is DONE it will return to the previous screen automatically.

Data Load settings

You can easily load any one of the ten available datasets saved in the CY-680B+.

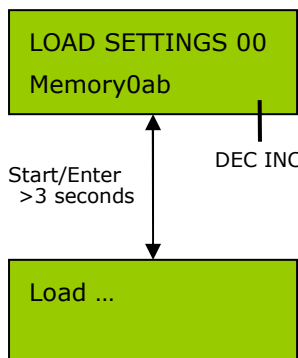

The "00" on the top line and the "memory0" on bottom line is the location you want to load dataset..

(Memory locations are in the range: 00 ~ 09)

The screen shows the charge is loading the data from the selected location.

NOTE:

You can load the dataset from any location you named in SAVE SETTING. For example, when you saved the following dataset as "01".

LiPo DISCHARGE 3.30V
1.0A 37.0V(10S)

When you want to load the dataset from "01", press the **START/ENTER** button for 3 seconds, the dataset will be displayed directly and prepare to conduct discharge.

LiPo DISCHARGE 3.30V
1.0A 37.0V(10S)

Warning and error messages

The CY-680B+ a wide range of protection and alarm functions to monitor the operation of charger. In the case of any error occurring the LCD will display the possible cause. **Press the STOP button to return, presses INC, DEC or START to check the final information displayed before alarming.**

REVERSE POLARITY CHECK	The battery pack is connected in reverse.
SHORT ERROR BREAK DOWN	The DC output leads are short-circuited.
CONNECTION BREAK DOWN	This will be displayed in case of detecting an interruption of the connection between the battery and the charger.
INPUT VOLTAGE LOW VOLTAGE	The input voltage is under the limit value set in the USER SET PROGRAM.
INPUT VOLTAGE OVER VOLTAGE	The input voltage is OVER 18V.
BALANCE PORT CELL LOW VOL	Using the Balance port, the cell voltage in the pack is too low. Please check the cell voltage one by one.
BALANCE PORT CELL HIGH VOL	Using the Balance port, the cell voltage in the pack is too high. Please check the cell voltage one by one.
BALANCE PORT NOT CONNECT	In Balance charge mode, no battery is connected to the balance port.
BATTERY CHECK LOW VOLTAGE	Without using the balance port, the cell count detected by the charger is less than that of the user setting.
BATTERY CHECK OVER VOLTAGE	Without using the balance port, the cell count detected by the charger is larger than that of the user setting.
Int. TEMP OVER CHG STOPPED	The internal temperature is over 65°C (149°F).
Ext. TEMP OVER CHG STOPPED	The external temperature (battery temp.) reached the limit.
CAPACITY OVER STOPPED	The capacity charged or discharged reached the limit.
SAFETY TIME OVER STOPPED	The charge or discharge time reached the limit.

Specifications

- Supported battery types: Li-Ion/LiPo/LiFe, NiMH/NiCd, Pb
- Battery count: 1~6 Li-Ion/LiPo and LiFe, 1-17 NiMH/NiCd, and 2-24V Pb
- Battery capacity: 50~99900mAH
- Input voltage: DC 11-18V, 20A
- Charge current: 0.05~10.0A
- Discharge current: 0.05~7.0A
- Charge power: 210W@ input voltage > 13.5V
- Discharge power: 20W(adjustable)
- Balancing current: 400mA/cell
- Balance Accuracy: <10mV
- Battery setup memories: 10
- Intelligent temperature control: yes
- Dimensions(L*W*D): 134*83*25mm(5.3"*3.3"*1.0")
- Weight: 350g with cables

Accessories below coming with the charger as **standard parts**

CW1 , Output leads, 4mm gold banana to alligator clips	CW2 , input leads, DC coaxial female to Alligator.	CEHP-7X Conversion Wire for balance charge
		

The accessories below as **optional parts**

CCB-7N-EH for 2S to 6S, 3*2S, 2*3S, Kokam/ Grauper battery pack	CCB-7TPQF for 2S, 3S, 4S, 5S, 6S TP, Flight power and Polyquest, Hyperion batteries pack	CCB-723TPQF for 2*3S and 3*2S TP, Flight power and Polyquest, Hyperion batteries pack
		
CW15 , Special Alligator with 4mm gold banana jack.	CW11 , input leads, Coaxial female plug to 4mm banana male connector	CW9 , Temperature Sensor.
		

<p>CW5, Output leads 4mm gold banana to JST</p>	<p>CW3, Output leads 4mm gold banana to Deans</p>	<p>CW4, Output leads 4mm gold banana to Tamiya</p>
		

Special designed power supply **A20** for CY-680B+ (Output DC 14V 16A 250W)



Maximum circuit power chart

When the battery voltage is more than 21V, the actual charging current delivered to the battery will be automatically limited so as not to exceed the charger's rated charging power of 210 watts. Similarly the discharge current will be limited when the battery voltage is more than 2.8V. The actual feeding current will be as follows:

Maximum charge and discharge current for various battery configurations @ input power > 13.5V and 250W

battery type	cell counts	rated voltage(V)	Charge current(A)	Discharge current(A)
Li-on	1	3.6	10.0	5.6
	2	7.2	10.0	2.8
	3	10.8	10.0	1.9
	4	14.4	10.0	1.4
	5	18	10.0	1.1
	6	21.6	10.0	0.9
LiPo	1	3.7	10.0	5.6
	2	7.4	10.0	2.8
	3	11.1	10.0	1.9
	4	14.8	10.0	1.4
	5	18.5	10.0	1.1
	6	22.2	10.0	0.9
LiFe	1	3.3	10.0	6.1
	2	6.6	10.0	3.0
	3	9.9	10.0	2.0
	4	13.2	10.0	1.5
	5	16.5	10.0	1.2
	6	19.8	10.0	1.0

battery type	cell counts	rated voltage(V)	Charge current(A)	Discharge current(A)
NIMH/NICD	1	1.20	10	7
	2	2.40	10	7
	3	3.60	10	5.6
	4	4.80	10	4.2
	5	6.00	10	3.3
	6	7.20	10	2.8
	7	8.40	10	2.4
	8	9.60	10	2.1
	9	10.80	10	1.9
	10	12.00	10	1.7
	11	13.20	10	1.5
	12	14.40	10	1.4
	13	15.60	10	1.3
	14	16.80	10	1.2
	15	18.00	10	1.1
	16	19.20	10	1.0
	17	20.40	10	1.0
Pb	1	2	10	7.0
	2	4	10	5.0
	3	6	10	3.3
	4	8	10	2.5
	5	10	10	2.0
	6	12	10	1.7
	7	14	10	1.4
	8	16	10	1.3
	9	18	10	1.1
	10	20	10	1.0
	11	22	10	0.9
	12	24	10	0.8

Warranty and Service

Chargery Power Co., Ltd. as manufacture of R/C model power warrants its CHARGER charger and battery pack to be free of defects in material and workmanship. This warranty is effective for 12 months from date of purchase. If within the warranty period the customer is not satisfied with the products performance resulting from a manufacturing defect the accessory will be replaced or repaired.

Your selling dealer is your first point of contact for warranty issues. Return postage costs are the responsibility of the user in all cases. Please submit copy of original receipt with the return.

Damage due to physical shock (dropping on the floor, etc.), inappropriate power supply (unstable output voltage and insufficient power, etc.), water, moisture, and humidity are specifically NOT covered by warranty. It is best to carefully check your charger before considering returning it as problems in setup, cabling, or power supply are much more common than defects in the charger. If there is damage stemming from these causes within the stated warranty period, the company will, at its option, repair or replace the charger for a service charge not greater than 50% of its then current retail list price.

Date of purchase/delivery:
Dealer:

NOTE:

CHARGER hope customers notify any change or modification made to this device.

Welcome any suggestions at jasonwang3a@163.com

Thanks and enjoy the power!