



WaveBook/516E™



Ethernet-Based Portable High-Speed Waveform Acquisition

Features

- 16-bit/1-MHz A/D
- 1 μ s/channel scanning of any combination of channels
- Single and multichannel analog triggering with programmable level & slope
- Digital TTL-level and pattern triggering
- Pulse trigger and external clock
- Programmable pre- and post-trigger sampling rates
- Sixteen digital inputs can be scanned synchronously with analog signals
- Operable from AC line, a 10 to 30 VDC source, such as a car battery, or optional compact rechargeable battery module
- Expandable up to 288 high-speed channels
- SYNC connection allows multiple units to sample synchronously
- Add up to 854 lower-speed thermocouple channels
- DSP-based design provides real-time digital calibration on all channels

Signal Conditioning Options

- ICP® dynamic signal inputs
- Strain gages
- Programmable filtering
- Simultaneous sampling
- Quadrature encoder inputs
- Pulse/frequency measurements
- Thermocouples
- High-voltage measurements
- Vehicle bus network

Software

- Includes **WaveView™** for *Out-of-the-Box™* setup, acquisition, & real-time display:
 - Scope mode for real-time waveform display
 - Logger mode for continuous streaming to disk
- Optional **eZ-Analyst™** for real-time spectrum analysis
- Support for Visual Studio® and Visual Studio® .NET, including examples for Visual C++, Visual C#, Visual Basic®, and Visual Basic® .NET
- Comprehensive drivers for **DASYLab®, LabVIEW®, and MATLAB®**
- WaveCal™ software application for easy user calibration

The WaveBook/516E™ digitizer offers multichannel waveform acquisition and analysis for portable or laboratory applications. The

For Vibration Applications, also consider the ZonicBook/618E



The WaveBook/516E is ideal for measuring dynamic signals in portable and laboratory applications

WaveBook includes 8 built-in channels expandable up to 72 channels of voltage, accelerometer, microphone, strain gage, thermocouple, position encoder, frequency, high voltage, and other signal types. For applications beyond 72 channels, up to four WaveBooks can be combined within one measurement system, for a total capacity of 288 channels. You can also add up to 854 thermocouples, without consuming measurement bandwidth of the WaveBooks, using the **WBK40™** series, and **DBK90** signal conditioning options.

WaveBooks are supported with a wide variety of software to address different applications and skill levels. Included WaveView software allows effortless setup, time-domain waveform viewing, and real-time storage of acquired data to disk*. Also included is **eZ-PostView™**, a post-acquisition waveform viewing application, allowing you to visually scroll through multiple waveforms on your PC screen. For users who prefer to program, the WaveBook also includes support for Visual Studio, Visual Studio .NET, C/C++, LabVIEW, MATLAB, and DASYLab.

Also included is **DaqCOM™**, an ActiveX/COM-based set of development tools that allow users to easily develop their own custom

applications in either Visual Basic, or C/C++. DaqCOM allows users to distribute WaveBooks throughout a facility of net-enabled PCs, allowing data acquired on any WaveBook attached on the network to be viewed on other PCs on the network.

Optional software for the WaveBook includes **eZ-Analyst**, a comprehensive, real-time vibration and waveform analysis package. **eZ-Analyst** converts the WaveBook and your PC into a flexible, interactive waveform analyzer.

DASYLab is also available for the WaveBook, allowing a user to simply connect icons to develop custom test and analysis applications.



WaveBook system with 8 strain inputs and 8 accelerometer inputs

* WaveView supports up to 72 high-speed input channels. Applications with multiple WaveBooks, or with WBK40/41 thermocouple options, should use DASYLab or other programming applications supported by the WaveBook, including C++, Visual Basic, or LabVIEW.

1 WaveBook Portable High-Speed Waveform Acquisition



WaveBook/516E™

General Information

A family of 8-channel **WBK expansion** options provide volts, accelerometer, strain gage, frequency, and quadrature encoder measurements. Other WBK options provide isolated inputs as well as temperature measurement capability. Most **WBK options** are fully programmable for gain/range, filter cut-off frequency, AC/DC coupling, etc.

The **WaveBook's** design is optimized for expansion, reconfiguration and portability. There are no bulky expansion chassis that must be purchased in anticipation of future applications. The compact, all-metal chassis features a low-profile package with front panel inputs.

The **WaveBook** provides sophisticated multichannel triggering, usually associated with larger, more expensive waveform recorders. The DSP-based design also makes the system more compact than others of similar performance.

The **WaveBook** operates on a wide range of power sources, such as a standard AC line, an optional rechargeable battery supply, or even a 12V car battery.

All WaveBooks feature an input buffer amplifier on each of its eight channels. This architecture isolates the input signals from any multiplexing transients and greatly improves frequency response. It also provides far less sensitivity to input-signal source impedance.

To achieve superior signal fidelity, excellent noise immunity, and greater accuracy, the **WaveBook** follows the input buffer amplifier with individual differential and programmable gain amplifiers on each channel. In addition, a 5-pole, 20-kHz Butterworth anti-aliasing filter can be software-enabled on a per channel basis to protect against aliasing of high-frequency signal components. For additional gain and filtering, the WaveBook can be factory configured with a **WBK11A™**, **WBK12A™**, or **WBK13A™**.

The **WaveBook's** DSP automatically compensates for offset and gain errors in each of its amplifiers, including those found in the WBK expansion options on a per-reading, real-time basis. This compensation is based on calibration constants calculated during

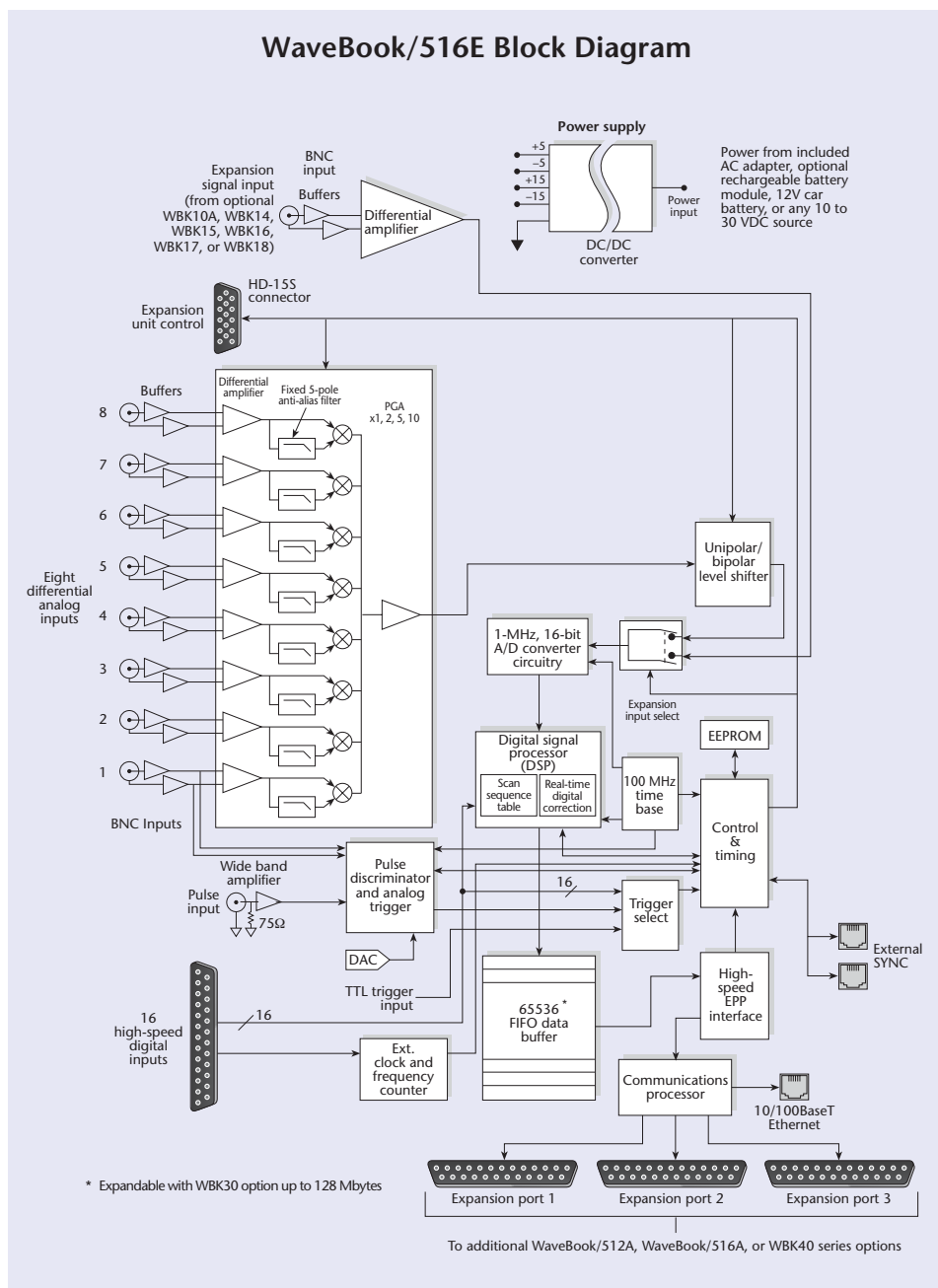

the system's calibration process. The constants are stored in the system's nonvolatile memory. The DSP also permits the WaveBook to accept user-supplied calibration constants, enabling it to automatically scale the input signal for gain and offset individually on every channel.

The **WaveBook** offers both bipolar and unipolar input ranges, which are per-channel

programmable via the sequencer. Bipolar ranges can extend from $\pm 0.05V$ to $\pm 10V$. Unipolar ranges can span from 100 mV to 10V.

The **WaveBook** also features a 16-bit high-speed TTL digital I/O port for recording discrete TTL-level signals at the beginning of each scan, providing time correlation with the analog inputs.



WaveBook/516E™

Triggering

Triggering

The **WaveBook** offers a variety of trigger modes. Selection of the optimal trigger mode for your particular application requirements saves time and disk space by ensuring that you capture only the data of interest.

A wide selection of programmable analog and digital trigger modes are available for starting an acquisition. All trigger modes, along with the number of scans and the sample rate for pre- and post-trigger data, are software programmable prior to the start of a scan sequence. The **WaveBook** also supports digital pattern and pulse triggering. Trigger latency (the maximum time from the trigger to the first reading of a scan group) and jitter (the variation of the latency from acquisition to acquisition) depend on the specific trigger source and type of acquisition. Descriptions of each trigger source and the various trigger modes follow.

Software Trigger. A software trigger is issued by the PC, and causes the **WaveBook** to begin scanning the setup predefined in the scan buffer. The trigger latency in this mode is longer than in other trigger modes and is a direct function of the PC's performance. It is typically 100 μ s or less in post-trigger acquisitions.

Digital TTL Trigger. The **WaveBook** accepts a single TTL-level signal input to the DB25 digital I/O connector with rising- or falling-edge trigger sensitivity selected through software. Trigger latency in this mode is less than 300 ns for post-trigger acquisitions.

Digital Pattern Trigger. In addition to digital trigger, the **WaveBook** supports digital pattern triggering. This allows data collection to start when a user-defined 16-bit digital pattern is matched on the digital I/O connector. For example, it is useful when trying to capture noise, vibrations, or some other physical disturbance which occurs at a particular point in a digitally sequenced

process, from a PLC or relay logic control system. Trigger latency of the digital pattern trigger is less than 300 ns for post-trigger acquisitions.

Pulse Trigger. This high bandwidth input enables the triggering and the correlation of lower speed waveforms with the occurrence of a high speed pulse. With Pulse Trigger, the user defines a pulse by an amplitude between $\pm 5V$ and a pulse width from 300 ns to 0.8 sec.

Analog Trigger Source. Analog sources are the most commonly used triggers. The **WaveBook** supports both single-channel analog triggers for quick captures, as well as multichannel analog triggering.

Single-Channel Analog Trigger. Simple single-channel trigger performs analog comparison of channel one to a programmable 12-bit DAC value. You can also select rising- or falling-edge criteria. Trigger latency is less than 500 ns.

When a **WBK11A**, **WBK12A**, or **WBK13A** option is installed (providing simultaneous sample and hold or filtering), the trigger input signal is amplified by the simultaneous sample and hold amplifier before being compared against the analog trigger level. This can increase the trigger signal's sensitivity by a factor of 100.

Multichannel Analog Trigger. Multichannel triggering eliminates spurious data by letting you enter a more selective trigger condition to capture events of specific interest. In multichannel mode, any combination of up to 72 analog channels can contribute to the trigger condition. You can individually program each channel to satisfy its trigger criteria using one of eight states from a combination of above/below level, rising/falling edge, and instantaneous/latched duration. In addition, you can also define a hysteresis band for each channel, reducing false triggers when used with auto re-arm. Finally, you can join all trigger channels together using

"ANY" (logical "OR" condition) or "ALL" (logical "AND" condition) Boolean logic operands to form a single, unified trigger condition.

The maximum latency possible in post-trigger acquisitions of the multichannel trigger mode is 2 μ s per designated trigger channel, plus 4 μ s. For example, if five trigger channels are designated, the maximum latency is 14 μ s. The minimum latency in this mode is half the maximum rate; thus, the multichannel trigger jitter time is 1 μ s per trigger channel, plus 2 μ s.

Acquisition Modes

The **WaveBook** lets you select one of several acquisition modes for collecting your pre- and post-trigger data. The system offers four post-trigger modes and two pre-trigger modes. The **WaveBook** uses a combination of internal memory, PC RAM, and your PC's hard disk to seamlessly record all acquired data during the acquisition process.

Post-Trigger Acquisition

In post-trigger acquisition, the **WaveBook** acquires data only after a trigger condition has been met. You have a choice of four post-trigger acquisition modes, each offering benefits suited to particular applications.

Infinite Linear Mode. In infinite linear mode, the system acquires data for an infinite amount of time after a trigger occurs. This mode is most useful for chart-recorder replacement applications that require long recordings. Once started, the system keeps digitizing until a "stop" command is issued by your PC. The amount of data you can acquire depends on your PC's available memory resources.

Infinite Circular Mode. In infinite circular mode, the system acquires data into a circular buffer indefinitely until it receives a "stop" command from the PC. When the circular buffer is full, it overwrites previously



WaveBook/516E™

Triggering

acquired data; thus the buffer always contains the most recently acquired data. This mode is most useful for applications in which file size is limited by PC resources, or an indeterminate number of scans will occur before the stop condition occurs and only the last scans are required. A typical application is destructive testing in which acquisition is complete when the device fails, and only the final failure mode characteristics need to be captured.

Finite Linear Mode. When operating in finite linear mode, the system acquires data after receipt of the trigger until a specified number of scans (from 1 to 100 million) are acquired. Finite linear mode is suitable for applications in which the duration of the event is known.

Re-arm. Finite linear mode permits the specification of the "re-arm" condition. Under such a condition, after a specified number of scans is acquired, the system automatically prepares for a new acquisition by re-arming and re-enabling the trigger, and then capturing a new finite number of scans without the need for either user or computer intervention. This capability is useful in emulating a DSO (Digital Storage Oscilloscope), which typically offers continuous retrace. It is also beneficial for unattended captures in which critical trigger events occur at indeterminate intervals, making manual re-arms awkward. It is further useful for applications in which trigger events occur so quickly that it is difficult to respond manually or under software control.

Finite Circular Mode. In this mode, the WaveBook acquires data into a circular buffer until a specified number of scans (from 1 to 100 million) is acquired. When the circular buffer becomes full, it writes over previously acquired data, and thus always contains the most recently acquired data. This mode is useful for trigger delays; for example, the unit can be pre-configured to record 100,000 scans (after the trigger) at 10 μs intervals and to save only the last 10,000 of the 100,000. In this example, the final record would contain only data acquired 900 ms after the trigger.

Channel-Scanning Flexibility

The WaveBook provides maximum scanning flexibility via a programmable channel/range sequencer. You can load the sequencer with any combination of channels and associated ranges. Once loaded, the sequencer waits for the trigger condition to be satisfied, after which it begins scanning and digitizing. When scanning begins, the WaveBook selects the appropriate channel and gain, digitizes the input signal, calibrates the reading, and transmits it to the PC via the on-board, 65 Kword FIFO buffer (or into optional internal memory, up to 128 Mbytes). This process is repeated at a 1 μs/sample rate until all channels within a scan group are completed.

Upon completion of a scan group, the WaveBook can be configured to proceed in one of several fashions. For example, the system can be programmed to begin the next scan after a

period of 1 μs to 100s, programmable in 0.05 μs increments. It can also be programmed to wait indefinitely until the trigger condition is next satisfied, after which it will again perform a specified number of scans, from 1 to 100 million.

The WaveBook also supports pre-triggering, and is capable of acquiring up to 100 million scans prior to satisfaction of the trigger condition. The pre-trigger buffer is circular, and thus always provides the most recently acquired readings prior to the occurrence of the trigger. In addition, the system permits pre-trigger scan group repetition at one rate and post-trigger scan group repetition at another rate. For example, the system can be configured to repeat scans 1,000 times per second prior to the trigger, and then 100,000 times per second after receipt of the trigger.

WaveBook Scanning Example

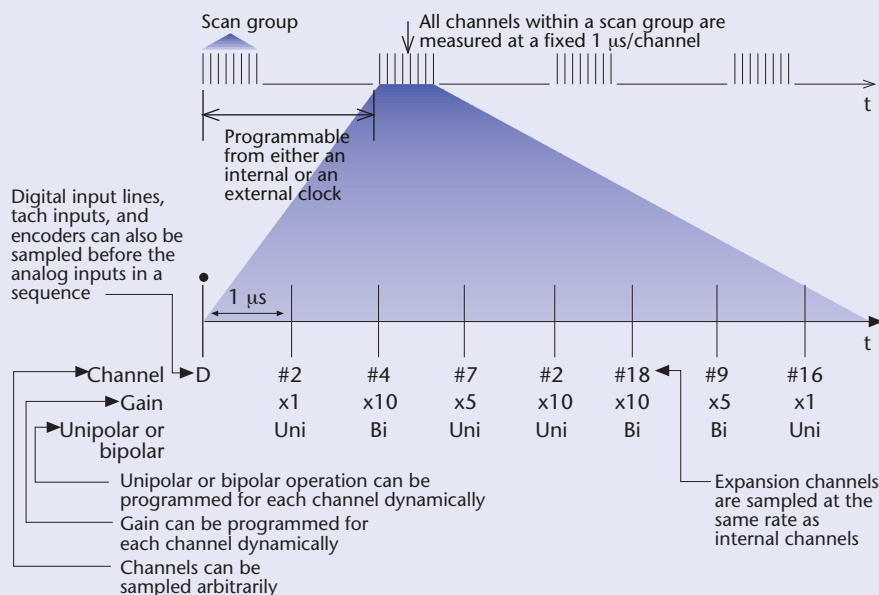



WaveBook/516E™

Triggering

Pre-Trigger Acquisition

Pre-trigger permits the acquisition of readings prior to the receipt of a trigger condition. Pre-trigger can be used with any of the four trigger modes described above.

When pre-trigger is selected, the rate at which a scan group repeats can differ before and after a trigger*. (Please note while the sample rates between pre- and post-trigger scan groups can differ, the time between consecutive samples within a group is fixed at 1 μs). For example, a scan group of 8 channels can be repeated at 1000 scans per second prior to a trigger condition, and at 100,000 scans per second after the trigger. The number of scans acquired during both time periods is also programmable.

The WaveBook first acquires a specified number of pre-trigger scans at the pre-trigger scan rate, and then arms the trigger, guaranteeing that at least the specified number of scans have been acquired before the trigger. The system continues to collect scans at the pre-trigger scan rate until the trigger occurs. Once the trigger is detected, the system finishes collecting the current pre-trigger scan, switches to the post-trigger scan rate, acquires readings using one of the four post-trigger modes described above, and then stops the acquisition. The number of pre-trigger and post-trigger scans are each independently programmable from 1 to 100 million.

Pre-Trigger Circular Mode (requires WBK30 installed). In this mode, data is placed into a circular buffer until the buffer fills, after which the buffer writes over previously acquired data. The system stays in this mode, waiting for the pre-set trigger condition to be met, until the condition occurs or the acquisition is halted by the PC. Upon detection of the trigger condition, the system begins the post-acquisition readings. Since, for practical applications, the WaveBook is

only limited by the PC's resources, extremely deep circular buffers can be configured for both the pre- and post-trigger data.

Pre-Trigger Linear Mode**. In this mode, the WaveBook continues collecting data without writing over old data. Since the amount of pre-trigger data can be nearly infinite (if the trigger takes a very long time to occur), this mode may require extensive PC resources to avoid data loss. Unlike the pre-trigger circular mode, which delays the trigger arm condition until a predefined number of scans is collected, the pre-trigger linear mode permits the WaveBook to begin recording post-trigger data as soon as the trigger condition is met, regardless of the number of pre-trigger scans collected. This mode is useful for applications in which the desired number of pre-trigger scans is indeterminate prior to the start of acquisition and all data must be acquired.

External Clock Input

The WaveBook supports an external clock input, allowing the scanning of data to be dependent upon an external pulse train. This feature is useful in rotating machine or motion applications where data collection is dependent upon rotational speed or axial position. In addition to allowing one scan per pulse, the WaveBook's external clock input features a programmable divider capable of reducing the incoming clock by up to 255. This is useful when the external clock source is faster than the optimum sample rate for the data collection task.

External Clock Timer†. The WaveBook features an internal timer capable of reporting the period of the external clock input. This value can be read with each scan†† of the analog data and is reset by the rising edge of the incoming clock. This is often beneficial in later analysis where physical phenomena needs to be correlated to speed.

Multi-Unit Synchronization

Multiple WaveBook/516As, WaveBook/512As, WaveBook/516Es, and WBK40/41s can be synchronized via the rear-panel SYNC ports. Simply connect 2, 3, or 4 WaveBooks together using SYNC cables (CA-74-1). WaveBook software establishes one of the WaveBooks as the "master" and the others as "slaves". Master WaveBooks can run at the full 1-MHz aggregate sampling rate; slave WaveBooks must have 0.1 μs of unassigned sampling time in the scan group (some trigger modes are not supported in multi-WaveBook systems).

Simultaneous Sampling†††

The WaveBook samples each channel in sequence, at a fixed 1 μs/channel rate. For example, when eight channels are scanned sequentially, the time between sampling the first channel and the eighth channel is 7 μs. For applications that require simultaneous sampling (within 100 ns) of all channels, the optional WBK11A eight-channel simultaneous sample and hold card and the WBK13A programmable low-pass filter card with simultaneous sample and hold are available. The WBK11A or WBK13A can be installed in the WaveBook, or the WBK10A™ expansion chassis; they provide simultaneous sampling of all channels in a module. Even when multiple WBK11A or WBK13A cards are used within one system, all channels with simultaneous sample and hold active are sampled within 100 ns of one another. Some WBK options include built-in simultaneous sampling, including the WBK16/SSH™, and WBK18™.

* eZ-PostView software does not support pre-trigger scan rates that differ from post

** Pre-trigger linear mode and auto re-arm in the WaveBook hardware are not supported in WaveView

† External clock counter and the high-speed digital inputs are mutually exclusive; adding the external clock counter to the scan list is equivalent to adding two analog channels

†† Requires two locations in the scan sequencer

††† The maximum scan rate when using SS&H is $\frac{1 \text{ MHz}}{(n + 1)}$ where n=number of channels in the scan list



WaveBook/516E™

System Power Connection

The WaveBook and its associated WBK modules offer the flexibility to be powered either directly from a 10V to 30V DC source or via the included TR-40U AC power adapter. Options such as the WBK11A, WBK12A, and WBK13A signal conditioning cards install directly into the WaveBook or WBK10A and derive their power from those units.

Table 1

Input	Maximum Output
DBK30A	1.9 Amps
DBK34A	5.0 Amps
TR-40U	3.3 Amps

If you are operating each module with its included TR-40U AC power adapters, then no calculations are required; just connect the power adapters. In certain applications, however, it may be advantageous or more convenient to operate all components from a single source such as a battery or UPS such as the DBK34A™. In those cases, the following worktables provide the necessary information for calculating current requirements for your particular system.

The table below shows the current draw available from IOtech's DBK30A™ rechargeable battery module, the DBK34A™ DC UPS, and the included TR-40U™ AC power adapter. To minimize cabling, each

module has a pass-through connector allowing a number of modules to be daisy chained, up to the 5-ampere limit of the connector and CA-115 power expansion cable. The exact number of daisy chained modules is dependent upon your exact configuration.

Calculating the Current

Table 2 provides the approximate required amperage for each component in your system when using a 15V supply. Using this table, calculate the maximum amount of amperage your system will draw by multiplying the quantity of components used by the amperage. Total the values in the last column to arrive at the maximum amperage; then verify that your power source has enough current capacity (see Table 1).

Table 2: Wavebook & Option Current Usage

Units	Qty.	Amps	Total
WaveBook/516E	x	2.10	=
WaveBook/512A and WaveBook/516A	x	1.40	=
WBK10A, 8-channel expansion module	x	0.30	=
WBK11A, 8-channel simultaneous sample & hold card	x	0.45	=
WBK12A, 8-channel programmable low-pass filter card	x	0.45	=
WBK13A, 8-channel programmable low-pass filter card with SS&H	x	0.50	=
WBK14, 8-channel dynamic signal conditioning module	x	0.85	=
WBK15, 8-channel 5B signal conditioning module	x	0.10	=
WBK15, with 8 5B strain modules (max load)	x	0.75	=
WBK16, 8-channel strain gage module (no load)	x	1.00	=
WBK16/SSH, 8-channel simultaneous sample & hold module	x	1.20	=
WBK17, 8-channel counter/encoder module	x	0.52	=
WBK18, 8-channel dynamic signal conditioning module	x	1.20	=
WBK30, memory option for the WaveBook	x	0.01	=
WBK40 series, modules for WaveBook/516E, with no expansion	x	0.60	=
WBK40 series, modules for WaveBook/516E, with five DBK84's	x	1.30	=
DBK65, 8-channel transducer interface module	x	0.83	=
DBK70, vehicle network interface*	x	0.50	=
Max. Amps:			<input type="text"/>

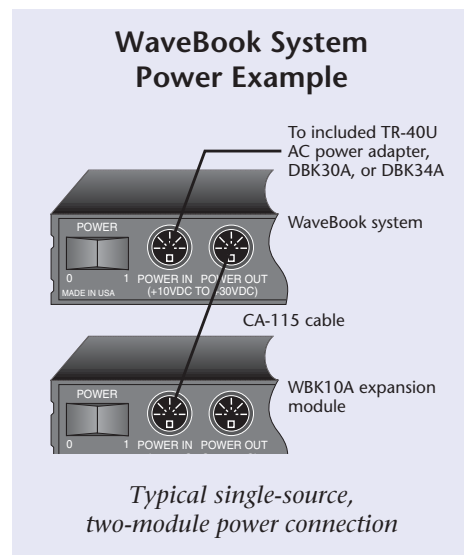

* Typically draws power from diagnostic connector



WaveBook/516E™

External Power Modules

DBK30A™

For small, portable applications, the optional **DBK30A™** rechargeable battery module provides up to 3.5 hours of operation at 2.0A current draw. The **DBK30A**, which is housed in a rugged metal enclosure of the same footprint as the WaveBook, and can be mounted under the system by using the built-in mounting brackets. The **DBK30A** includes an AC charging supply.



The **DBK30A** rechargeable battery/excitation module

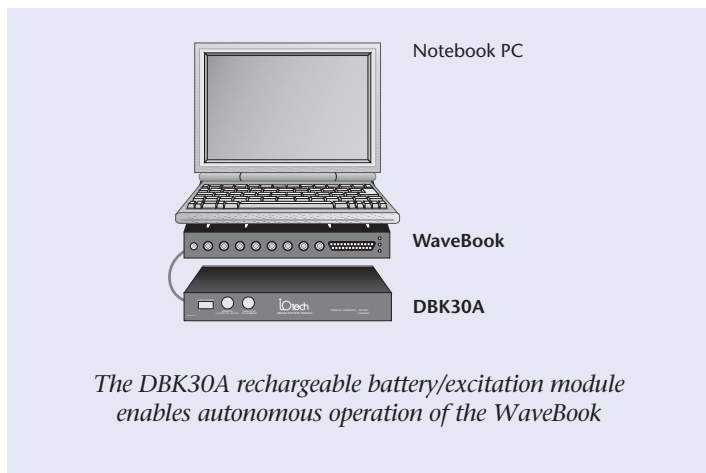

DBK34A™

The **DBK34A™** provides back-up power as an uninterruptible power supply (UPS) to the WaveBook. If DC power is interrupted during an acquisition, this module provides temporary power so the measurement is not disturbed. The **DBK34A** is powered from an external DC power supply; it does not include an AC charger.



The **DBK34A** rechargeable lead-acid battery/UPS (uninterruptible power supply) module

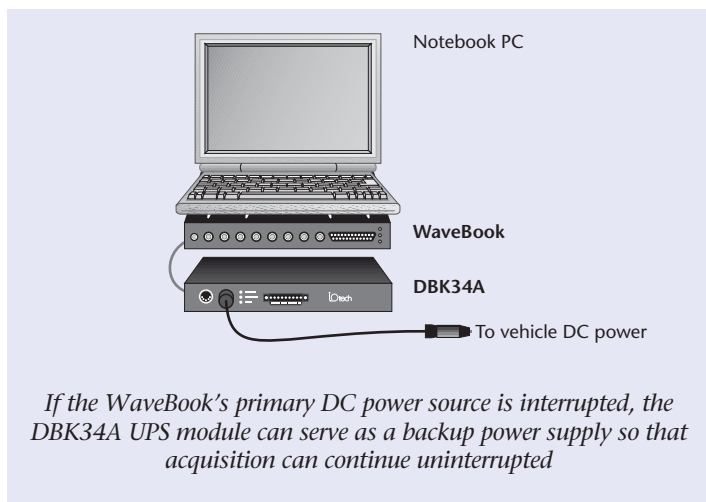

The **CA-116** optional cigarette-lighter power adapter provides DC power to the WaveBook in automotive applications



WaveBook/516E™

Ethernet Features

The WaveBook/516E™ transfers acquired data to the PC via 10/100BaseT Ethernet, allowing a continuous stream of a virtually unlimited amount of data to be collected and stored in a PC's memory or hard drive.

The 8-channel WaveBook/516E can be expanded up to 72 channels using 8-channel WBK expansion options. The WaveBook/516E also has 3 built-in parallel expansion ports, permitting connection of up to three additional WaveBook/516A™, WaveBook/512A™, or WBK40™ series units. A sync signal between all devices insures that multi-device systems acquire data synchronously. In total, up to 288 channels of high-speed input can be measured via one Ethernet link*. Also, additional channels are possible using an Ethernet expansion hub, allowing multiple WaveBook/516E units to be attached to one PC.

A virtually unlimited number of WaveBook/516E units can be attached to a PC when multiple Ethernet ports are employed. The WaveBooks can be operated as one synchronous system, or can be operated as entirely independent systems, each with their own independent triggering and sampling rates.

The WBK40 series of options connect to one of the WaveBook/516E's parallel expansion ports. Since the WBK40 has its own 200-kHz A/D converter, it does not consume bandwidth from the WaveBook's 1-MHz A/D. The SYNC connection insures that both A/Ds measure synchronously.



The WaveBook/516E includes a 10/100BaseT Ethernet interface

There are two advantages of seamlessly supporting multiple WaveBooks in one system. First is the ability to expand beyond the 72 channel capacity of a single WaveBook. Second, if the per-channel sampling rate of a single WaveBook system is inadequate, then additional WaveBooks can provide more bandwidth per channel. For example, a 16-channel, single WaveBook/516E system with one WBK option provides a maximum bandwidth of $1M/16 = 62.5$ kHz/channel. Instead, the system could have one WaveBook/516E with one slave WaveBook/516A, providing a per channel sampling rate of $1M/8 = 125$ kHz.

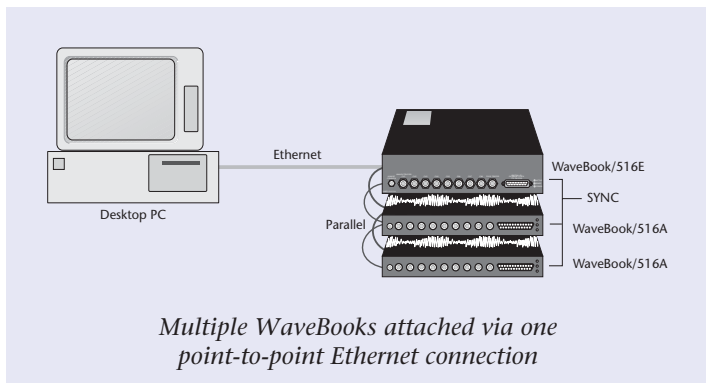

Multiple WaveBooks attached via one point-to-point Ethernet connection

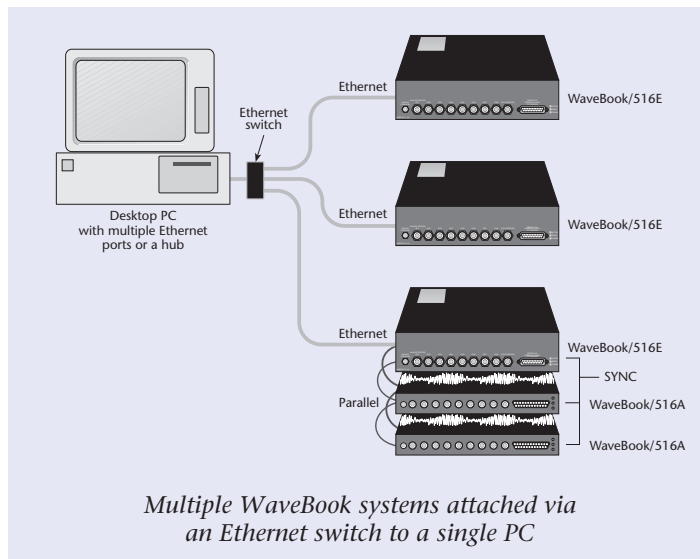

Multiple WaveBook systems attached via an Ethernet switch to a single PC

* The maximum continuous data transfer rate from a multiple WaveBook system to the PC on a dedicated Ethernet link is 2 Mreadings/s.



WaveBook/516E™

General Information

The most common and highest-performance [WaveBook/516E](#) connection is with dedicated, point-to-point Ethernet link between the PC and the WaveBook/516E. Data transfer rates in this configuration will accommodate continuous, 1 Mreading/s transfers from the [WaveBook/516E](#) to the PC.

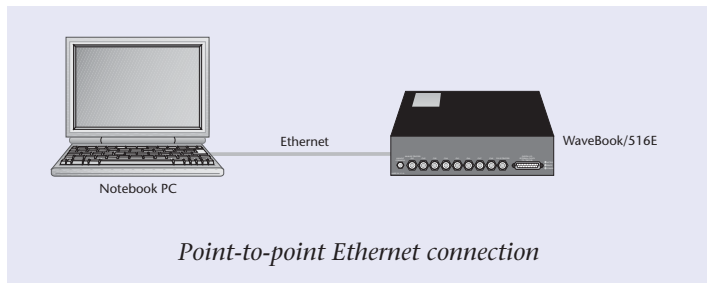

With an enterprise-wide Ethernet network connection, any number of [WaveBook/516E's](#) can be connected to the network, which is shared amongst a potentially large number of Ethernet-connected devices. In this mode, the data transfer rates from the WaveBook/516E will be dependent on other network traffic at

the time of data transfer. This connection method is not recommended when continuous, 1 Mreading/s transfers from the [WaveBook/516E](#) are required. To improve the data transfer performance of WaveBook/516E's in this configuration, the [WBK30™](#) memory options may be installed into the [WaveBook](#).

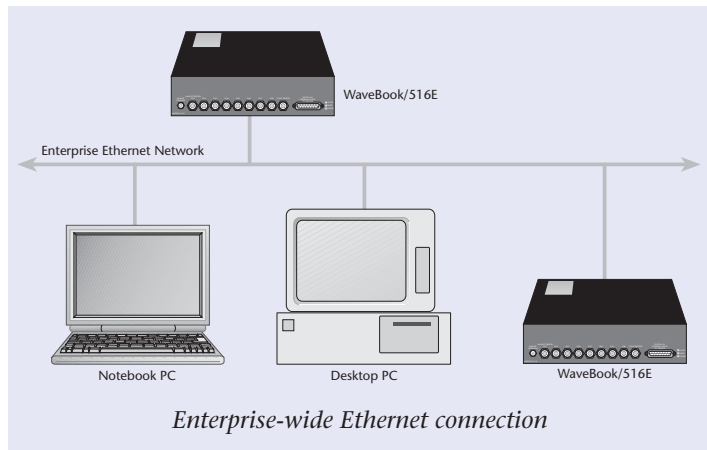

1 WaveBook
Portable High-Speed Waveform Acquisition

The parallel expansion ports on a [WaveBook/516E](#) can also be used to attach a fourteen channel WBK40 thermocouple interface module. The [WBK40](#) has an internal A/D converter, so that it does not consume valuable bandwidth from the [WaveBook516E's](#) 1-MHz A/D converter. The SYNC signal on the WaveBook attaches to the SYNC input on the WBK40, insuring that both A/D's are operating synchronously to one another. The [WBK40](#) can be expanded up to 244 thermocouple channels using [DBK84](#) 14-channel TC interface modules.

In synchronous master/slave systems or when using a WBK40/41 module, it is possible to run the slave units at a slower clock rate than that of the master device in the system. This configuration may be necessary when it is desirable to have a system which has signals that need to be sampled at widely varying rates while remaining time synchronous to the master unit.

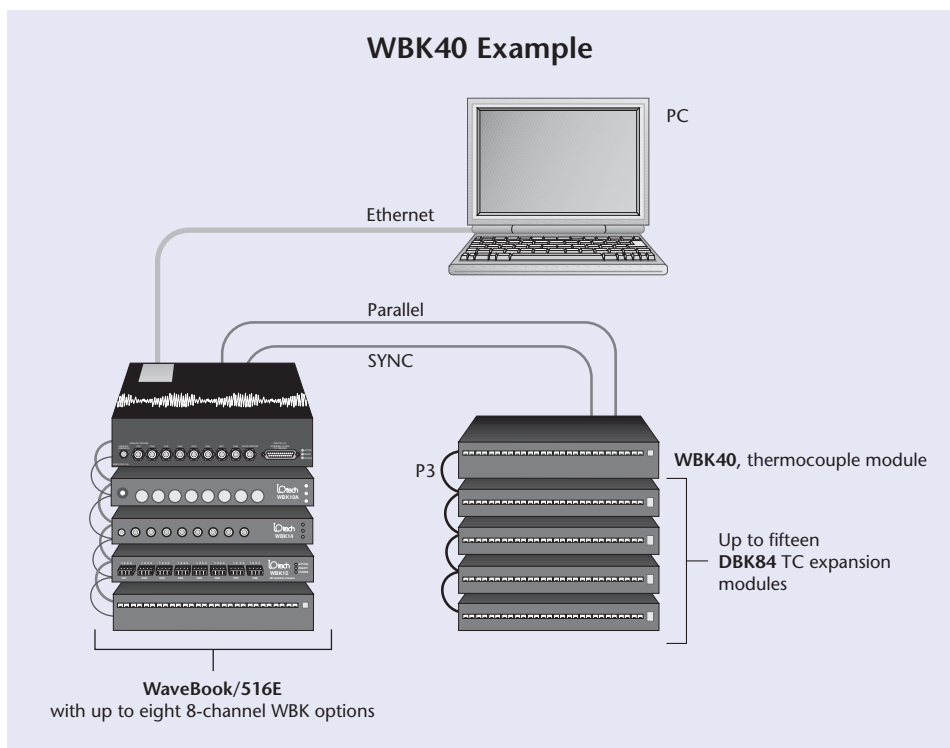

Note: The WBK40™ and WBK41™ are not currently supported in WaveView™. We recommend using DASYLab® when using these modules, which includes full support for the WBK40/41. The WBK40/41 are also supported in LabVIEW®, DaqCOM™ and with our Windows® API DaqX DLL. If it is necessary to use these modules in conjunction with a WaveView application, then it is necessary to launch a second, concurrent application to acquire data from the WBK40/41 into separate data files.



WaveBook/516E™

General Information

288-Channel System Example

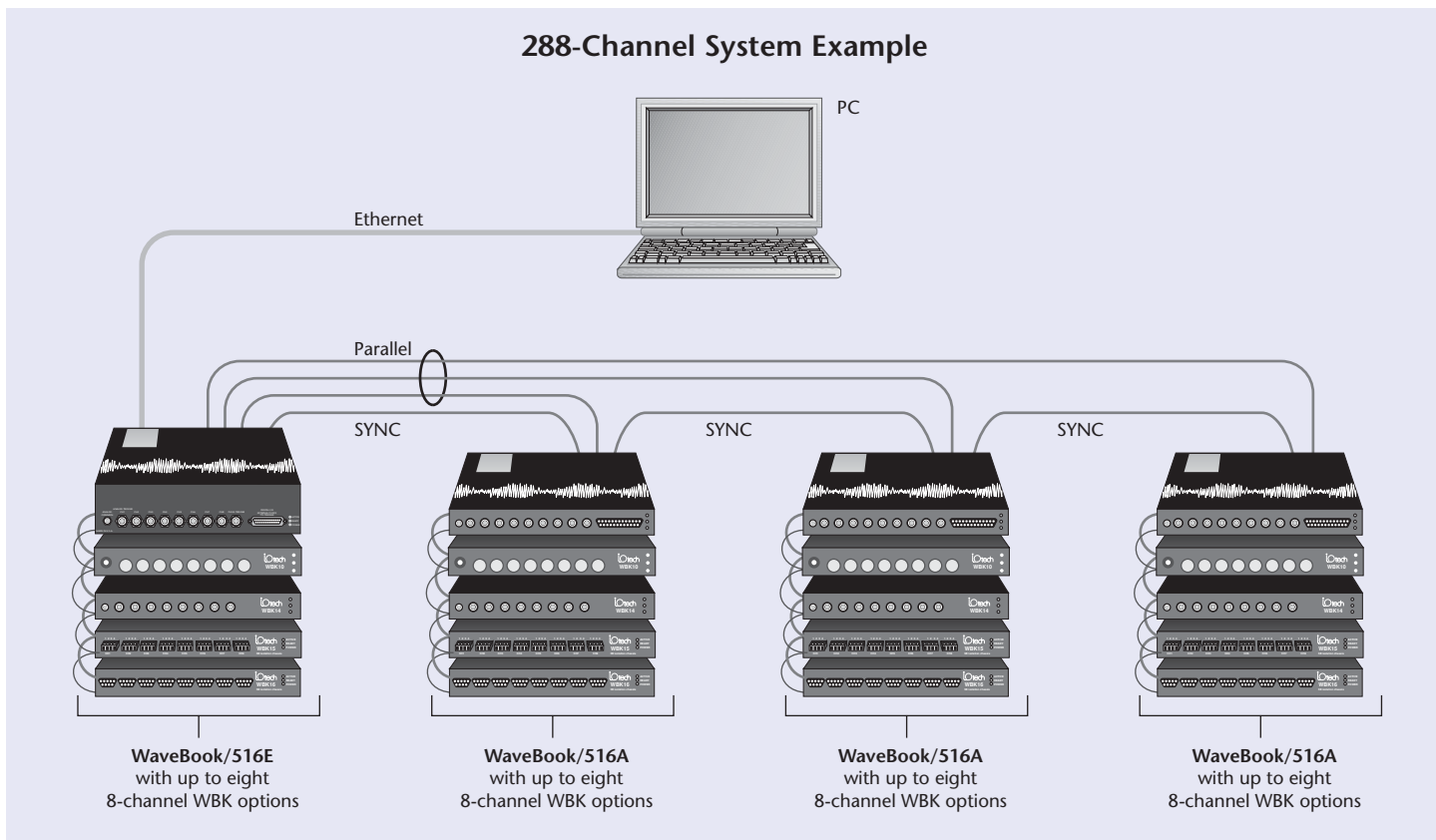

A large WaveBook system can be configured with one Ethernet link to the PC, and would include one WaveBook/516E and three WaveBook/516A or WaveBook512A units. Each WaveBook system can be configured up to its standard maximum of 72 channels* for a total system capacity of 288 channels.

In addition, each WaveBook in the system can be run independently or synchronized using the built SYNC ports on each WaveBook. When synchronized any WaveBook in the system can be configured as the master or controlling unit. The master

unit then controls the triggering and clocking of all the other WaveBooks in the system.

WaveBook software can establish one of the WaveBooks as a "master" and the others as "slaves". Master WaveBooks can run at the full 1-MHz aggregate sampling rate; slave WaveBooks must have 0.1 μs of unassigned sampling time in the scan group (some trigger modes are not supported in multi-WaveBook systems). The maximum data throughput rate with the system above is approximately 2 Mreadings/s. Alternatively, for highest performance use 4 Ethernet WaveBook/516Es with a 4 port Ethernet switch.

WaveBook/512A & /516A

General Information

The 12-bit WaveBook/512A and 16-bit WaveBook/516A attach to the WaveBook/516E via their built-in parallel port interface. Other than the interface, the WaveBook/512A and WaveBook/516A are identical to the WaveBook/516E. For applications where the continuous data transfer rate may not be fast enough to insure that no data is lost, the WBK30 series of internal memory options can be installed into any model of the WaveBook. The WBK30 series act as a large data FIFO.

* Use of WBK40/41 modules allows the total channel capacities of each WaveBook system to be much higher.



WaveBook/516A includes a parallel port for connecting to the WaveBook/516E



Module-to-Module Connection for WaveBook Systems

Assembling a **WaveBook™** system is easy with our new packaging and module-to-module connection system. Every WaveBook and **WBK™** option is housed in an all-metal enclosure, and is encased with rugged molded bumpers on all corners. The bumpers serve to protect the connectors as well as to attach multiple modules together. Within each bumper is a tab which can be rotated 90° to lock with other modules attached to either the top or bottom of each module. The end result is a rugged system that can be expanded to a virtually unlimited number of modules.

One handle is included with each **WaveBook**, and additional handles can be purchased for in-vehicle applications where a handle on both sides of the system is desirable for securing the system to the vehicle. When multiple modules are attached in a system, the handle can be easily moved from the WaveBook to any other module in the system.

For owners of existing **WaveBook** and/or **WBK** systems, the new bumpers can be easily added to your existing hardware. Contact IOtech or your local IOtech representative for details.



*Built-in connection tabs in every expansion module make assembling a system easy – above illustrates how a **WBK18** would attach to a **WaveBook/516E***



*An assembled system consisting of a **WaveBook/516E** plus one **WBK18** accelerometer module plus one **WBK16** strain gage module*



WaveView™

Out-of-the-Box™ Software



WaveView™

WaveView is a Windows-based setup and acquisition application that allows you to configure, display, and save data to disk within minutes of taking the WaveBook™ Out-of-the-Box™. WaveView provides a point-and-click interface that simplifies operation of the WaveBook by allowing setup of all hardware, including the field-installable WBK options, without programming or connecting icons.

Unlike the mere example programs that many suppliers provide with data acquisition hardware, WaveView is a full-featured acquisition and display engine that provides all the functionality needed for many data-logging and display applications. For more frequency-domain analysis applications, use eZ-Analyst™ or DASyLab®.

WaveView's intuitive approach to hardware control simplifies system setup by automatically querying the WaveBook upon connection to your PC. As WBK options are added for signal conditioning or increased system channel count, WaveView's channel configuration spreadsheet automatically expands to accommodate the additional channels. Specific channel characteristics, such as gain, unipolar/bipolar, and channel labels, are automatically updated, and any additional functionality (such as low-pass filtering, filter cutoff, or excitation output), also automatically appear in the channel-configuration spreadsheet. WaveView is also designed for easy operation with display and analysis packages. WaveView provides data in formats compatible with a variety of sophisticated display and analysis packages, including MATLAB™.

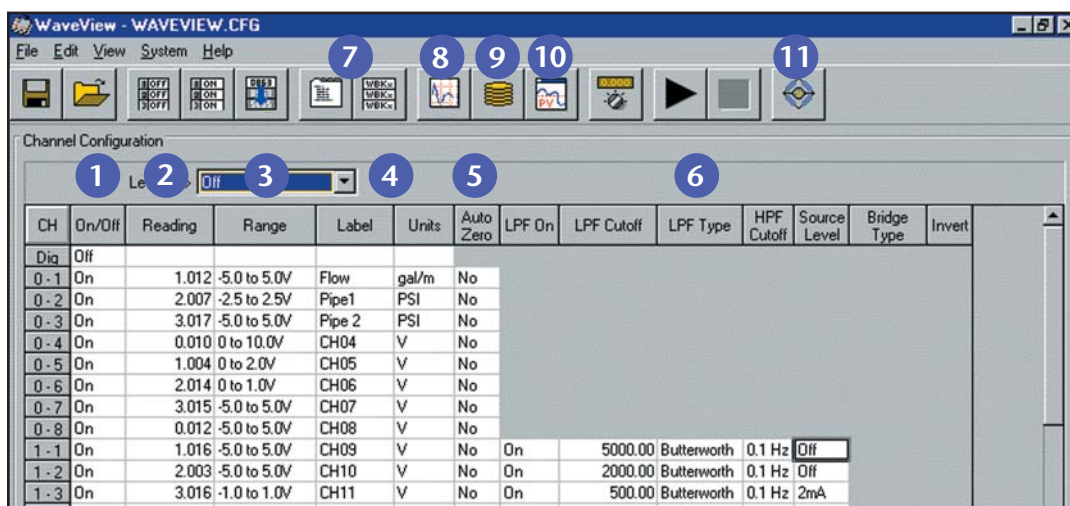

Note: The WBK40™ and WBK41™ are not currently supported in WaveView™. We recommend using DASyLab® when using these modules, which includes full support for the WBK40/41. The WBK40/41 are also supported in LabVIEW®, DaqCOM™ and with our Windows® API DaqX DLL. If it is necessary to use these modules in conjunction with a WaveView application, then it is necessary to launch a second, concurrent application to acquire data from the WBK40/41 into separate data files.

Included WaveView is an Out-of-the-Box™ setup, acquisition, and real-time display program

- 1 Designate an individual data channel as active or inactive by clicking on a select channel.
- 2 Reading column provides quick indication of sensor condition before acquisition begins.
- 3 Choose different ranges or gains for each channel, based on the particular WBK options installed. Bipolar and unipolar scales can also be selected for each channel.
- 4 Assign each channel a unique label, which will be automatically referenced throughout WaveView. Choose the desired engineering units in which to display acquired data, based on the installed WBK options. Parameters can also be entered to perform mX+b scaling on each reading before displaying it.
- 5 Use auto-zero to remove small offsets such as transducer drift or pre-load conditions prior to acquisition.
- 6 Enhanced features such as filter type, cutoff frequency, ICP® current source, and bridge configuration automatically appear when hardware is added to the WaveBook system. There are no switches to set and WaveView automatically updates itself for new configurations.
- 7 Click to review system configuration and acquisition parameters such as scan rate, pre- and post-trigger usage, and trigger criteria.
- 8 Scope Mode allows customizing and displaying of multiple traces; it supports cursors, re-scaling, and more.
- 9 Store data to disk in real-time; the auto re-arm function, with automatic file naming, supports back-to-back acquisition of over one million captures without user intervention.
- 10 Review acquired waveforms with a strip chart style display via eZ-PostView™.
- 11 Strain gage setup to calibrate WBK16™ strain gage channels.



WaveView™

Out-of-the-Box™ Software

Scan and Trigger Configuration. The WaveBooks' powerful event-capture capability is made available through the simple, fill-in-the-blank style boxes in WaveView. In addition to single-channel, manual, and external TTL, advanced triggering for multichannel, digital pattern, and pulse trigger is also available. When using multichannel trigger all channels can be combined with boolean "AND" & "OR" operators to begin the acquisition at just the right time. In digital pattern mode, the WaveBook triggers on a user-defined bit pattern making it easy to associate analog data with digital sequences.

Unique to the WaveBook is the pulse trigger capability shown below. Typically available in systems many times its price, pulse trigger allows capturing that elusive event by defining the level of the signal and pulse width criteria. Now "runt" pulses or glitches buried in apparently good signals can be easily captured.

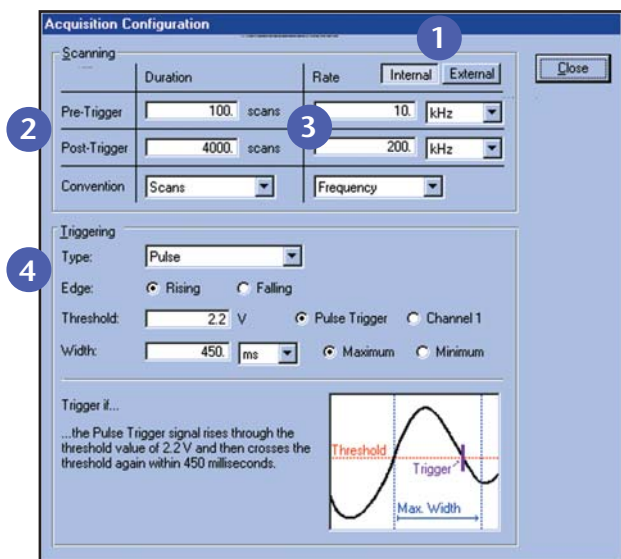

You can configure the WaveBook via WaveView's scan and trigger configuration screen

- 1 Allows selection of internal or external clock.
- 2 Lets you individually set acquisition duration for both pre- and post-trigger data.
- 3 Offers separate scan rates for both pre- and post-trigger data.
- 4 Select the trigger mode you need: immediate, manual, multichannel, digital pattern, or pulse.

Scope Mode. Unlike a traditional scope with only two to four channels, WaveView's Scope Mode allows any eight channels to be displayed. Furthermore, WaveView is not handicapped by the small memory limitations of DSOs. In fact, WaveView dynamically and transparently allocates a PC's RAM prior to beginning an acquisition. A simple point-and-click is all that's necessary to initiate multi-Msample acquisitions. In addition, because the data is already in the PC's RAM, a second point-and-click on the disk icon automatically saves this data to disk for import into eZ-PostView, a post-acquisition waveform review package, or into analysis packages, such as MATLAB™, DADiSP™, or Excel™.



Scope Mode allows you to display any eight of the WaveBooks' channels

- 1 Supports continuous or single-shot capture and display modes.
- 2 Provides zoom-in and zoom-out window control of the x-axis.
- 3 Displays user label and cursor data values.
- 4 Scroll through all data.
- 5 Provides auto-scale for quick maximization of the y-axis display.
- 6 Automatically scales axis in user-defined engineering units.
- 7 Enables cursor for on-screen measurements.



WaveView™

Out-of-the-Box™ Software

Logger Mode. For applications where PC RAM is insufficient to record the entire test or where rapid back-to-back recordings need to be saved to disk, WaveView provides a Logger Mode. It complements WaveView's Scope Mode by allowing continuous* recording data directly to disk.

Logger Mode can auto-increment file names to provide the unattended capture of millions of back-to-back events, without user intervention. Acquired data can be stored in several data formats for direct import to packages such as MATLAB™, Excel™, or eZ-PostView™.

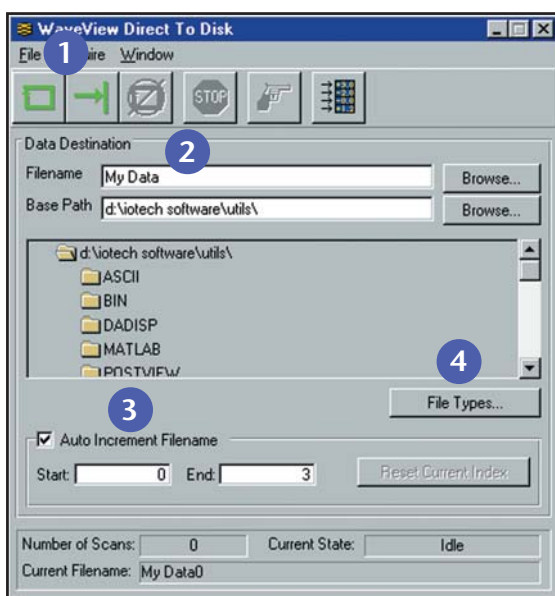

WaveView's Logger Mode can stream data direct to disk in a variety of formats

- 1 Allows the collection of single-shot or auto-increment file names for back-to-back acquisitions.
- 2 File name, path, and auto-increment index can be entered by simply filling in the blank.
- 3 Auto increment creates multiple data files, one per trigger.
- 4 Choose from an ever-growing list of data file formats for easy importing into other software packages such as DADiSP, DASyLab, MATLAB, Snap-Master, ASCII/Excel Universal File Format (UFF) 58A (ASCII), Universal File Format (UFF) 58B (Binary), and .WAV.

eZ-PostView™

The basic eZ-PostView system that is included free with the Out-of-the-Box™ application software is powerful, yet easy-to-use. eZ-PostView's interactive graphics make it possible to quickly inspect enormous data files at fast speeds. Interactive zooming and cursors allow the user to view even the smallest details of collected data.

As needs evolve, the basic system can be enhanced by adding optional software modules. When needs exceed the capabilities of the free eZ-PostView, add-on eZ-PostView options are available that provide additional data viewing and management tools along with data analysis capabilities.

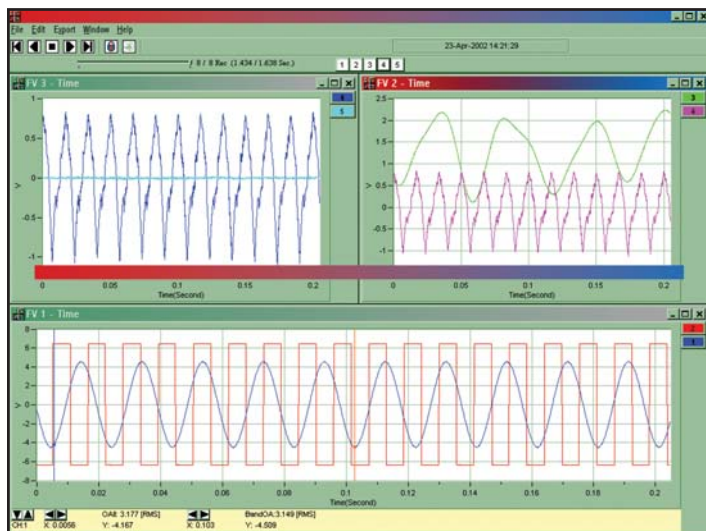

eZ-PostView, a Windows®-based, post-acquisition waveform viewing application

WaveCal™

The WaveBook is shipped with WaveCal, an application that facilitates periodic calibration of the system. Although all WaveBook components are factory-calibrated to their rated accuracies prior to shipment, annual recalibration is recommended. WaveCal's simple on-screen instructions and direct access to the WaveBook's components make recalibration fast and easy.

* For acquisitions in excess of 100 million scans, use DASyLab® or other available software



WaveBook™ Series

Specifications & Ordering Information

General Specifications

Warm-up: 30 minutes to rated specifications

Environment

Operating: 0° to 50°C, 0° to 95% RH, non-condensing
Storage: -20° to 70°C

Power Consumption

/516E: 1.8A max @ 15 VDC
 /516A & /512A: 1.4A max @ 15 VDC

Input Power Range: 10 to 30 VDC

Vibration: MIL STD 810E

PC Communication

/516E: 10/100baseT Ethernet (300 ft. max)
 /512A and /516A: Enhanced Parallel Port (EPP)

Channel Capacity

/516E: 8 built-in voltage channels, expandable to 72 channels with WBK options. Also can accommodate up to 3 additional WaveBook/516A, /512A, or WBK40 series options (any combination). Each /516A or /512A can be expanded up to 72 channels. Maximum WBK41 capacity is 854 TC input channels, 4 analog output channels, 272 digital I/O channels, and 6 counter/timer channels (see WBK40 on for details).

/516A & /512A: 8 built-in voltage channels, expandable up to 72 channels using WBK options.

Dimensions

/516E: 285 mm W x 220 mm D x 70 mm H (11" x 8.5" x 2.70")

/516A & /512A: 285 mm W x 220 mm D x 45 mm H (11" x 8.5" x 1.75")

Weight

/516E: 1.9 kg (4.2 lbs)
 /516A & /512A: 1.5 kg (3.3 lbs)

Handle: One carrying handle is included with each WaveBook

Analog Inputs (18° to 28°C)

Channels: 8 differential, expandable up to 72 differential

Connector: BNC

Resolution

/516A & /516E: 16 bit
 /512A: 12 bit

Ranges: Unipolar/bipolar operation is software selectable via sequencer

Unipolar*: 0 to +10V, 0 to +4V, 0 to +2V
Bipolar: ±10, ±5V, ±2V, ±1V

Maximum Overvoltage: ±35 VDC

Input Bandwidth: DC to 500 kHz

Input Impedance

Single-Ended: 5M Ohm in parallel with 30 pF
Differential: 10M Ohm in parallel with 30 pF

Accuracy

/516A & /516E:
 ±2 to ±10V: ±0.012% of reading; 0.006% of range
 ±1V: ±0.018% of reading; 0.008% of range
 /512A: ±0.03% of reading; 0.006% of range

Input Noise

/516A & /516E: <2 LSB (RMS)
 /512A: <1 LSB (RMS)

Total Harmonic Distortion: -84 dB typ

Signal to Noise and Distortion: +74 dB typ

CMRR: 80 dB typ; 70 dB min; DC to 20 kHz

Anti-Alias Filter*

Type: 5-pole Butterworth; 20-kHz, low-pass software enabled

* No unipolar mode or anti-alias filter with WBK11A, WBK12A, or WBK13A installed

Triggering

Channel 1 Analog & Pulse Trigger

Input Signal Range: -10 to +10V
Bandwidth: 1 MHz
Latency: 300 ns

Multi-Channel Analog Trigger (up to 72 channels):

Range: Selectable per channel to input range
Latency: 2 µs/channel, plus 4 µs maximum

TTL Trigger

Input Signal Range: 0 to 5V
Input Characteristics: TTL-compatible with 10K Ohm pull-up resistor
Latency: 300 ns

Software Trigger

Latency: 100 µs typical

Pulse Trigger Input

Input Signal Range: ±5V
Input Characteristics: 75 Ohm
Input Protection: ±10V maximum
Minimum Pulse Width: 100 ns
Maximum Pulse Width: 0.8 sec
Latency: 300 ns

External Clock

Connector: Available on DB25 digital input

Input Signal Range: 5V TTL compatible

Input Characteristics: 50K Ohms pull up (to +5V) in parallel with 50 pF

Input Protection: Zener clamped -0.7 to +5V

Delay: 200 ns

Signal Slew Rate Requirement: 20V/µs minimum

Rate: Up to 1 MHz

Divisor Ratio: Divide by 1 through 255, selectable

Clock Counter Accuracy: <0.02% error

Clock Counter Range: 0.01 Hz to 100 kHz

Sequencer

Operation: Programmable for channel, gain, and for unipolar/bipolar range in random order

Depth: 128 location

Channel-to-Channel Rate: 1 µs to 1.1 µs/channel, all channels equal

Maximum Repeat Rate: 1 MHz

Minimum Repeat Rate: 100 seconds per scan

Expansion Channel Sample Rate: Same as on-board channels, 1 to 1.1 µs, fixed

High-Speed Digital Inputs/General-Purpose Outputs

Connector: DB25 Female

Configuration: 16 TTL-compatible pins, selectable for input or output

Input Characteristics: TTL-compatible

Output Characteristics: ALS TTL output in series with 33 Ohms

Output Updates: Outputs may be changed via program control

Input/Output Protection: Diode clamped to ground and +5V

Ordering Information

Description	Part No.
16-bit Ethernet, 1-MHz portable data acquisition system includes WaveView, and eZ-PostView; support for Visual Studio® and Visual Studio® .NET; drivers for DASyLab®, LabVIEW®, and MATLAB®; and WaveCal™ software application; and AC adapter	WaveBook/516E

Description	Part No.
16-bit parallel, 1-MHz portable data acquisition system includes WaveView, and eZ-PostView; support for Visual Studio® and Visual Studio® .NET; drivers for DASyLab®, LabVIEW®, and MATLAB®; and WaveCal™ software application; and AC adapter	WaveBook/516A
12-bit parallel, 1-MHz portable data acquisition system includes WaveView, and eZ-PostView; support for Visual Studio® and Visual Studio® .NET; drivers for DASyLab®, LabVIEW®, and MATLAB®; and WaveCal™ software application; and AC adapter	WaveBook/512A

Accessories

Rack mount kit for /516A, /512A	RackDBK3
Rack mount kit for /516E	RackDBK4
Optional hardcopy manual set (2); includes programmer's manual, and WBK option cards & modules user's manual	489-0900

Cables

Ethernet patch cable, 1.5 ft.	CA-242
Ethernet patch cable, 7 ft.	CA-242-7
DB25 male to DB25 female parallel cable, 2 ft.	CA-35-2
SYNC cable, 1 ft.	CA-74-1
5-pin male DIN to 5-pin male DIN	CA-115
5-pin DIN to automobile cigarette lighter power cable, 8 ft.	CA-116
DB25 to external clock BNC	CA-178
CE Compliant Cables	
1 male BNC to male BNC	CA-150-1
8 male BNC to male BNC	CA-150-8

Software

Icon-based data acquisition, graphics, control, and analysis software with WaveBook driver	DASyLab
Real-time vibration analysis and recording software for the ZonicBook and WaveBook	eZ-Analyst
Post-acquisition time-domain analysis software for data acquired from the WaveBook	eZ-TimeView
Post-acquisition frequency-domain analysis software for data acquired from the WaveBook	eZ-FrequencyView

For complete information on accessories and cables, visit www.iotech.com/acc

Related Products

Hardware
ZonicBook
WBK Options
DBK Options
Software
WaveView
eZ-Analyst
DaqCOM
DASyLab
eZ-TimeView
eZ-FrequencyView