

RF Wireless LED Dimmer

Model:BL28-01E with BL25-01N series



Feature

- Reliable stable switch and dimming control function, control range $\geq 20M$.
- Battery in the remote is with long life span. It normally can use for 2 years.
- Switch on/off of lightings slowly, without any flash, meet the comfort of human eyes.
- Dimming range 0.1-100%.
- Use with power repeater to expand the output power unlimitedly.
- Enable to control receiver's 4 output channels separately.
- Push dim function

Product introduction

The BL28-01E and its receiver is a RF Wireless LED Dimmer. It lets you individually control 4 channels independently.

Parameter

Remote

Part No.	Operation Voltage	Operation Frequency	DIMENSIONS ϕ/h (mm)	REMARKS
BL28-01E	3VDC	434MHz/868MHz	40x136.5x11.5	RF Wireless

Receiver

Part No.	Input Voltage	Current	Output	Remarks
BL25-01N	12-36VDC	4x5A	4x(60-180)W	Constant voltage
BL25-01N-DIN	12-36VDC	4x5A	4x(60-180)W	Constant voltage

Product Size

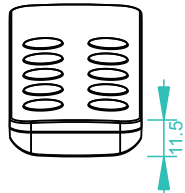
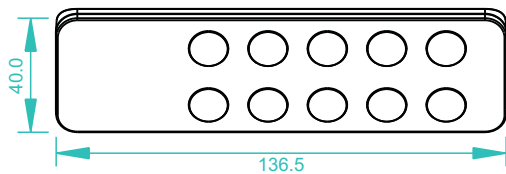

Wiring diagram

1)Receiver Connection Diagram for Single Unit

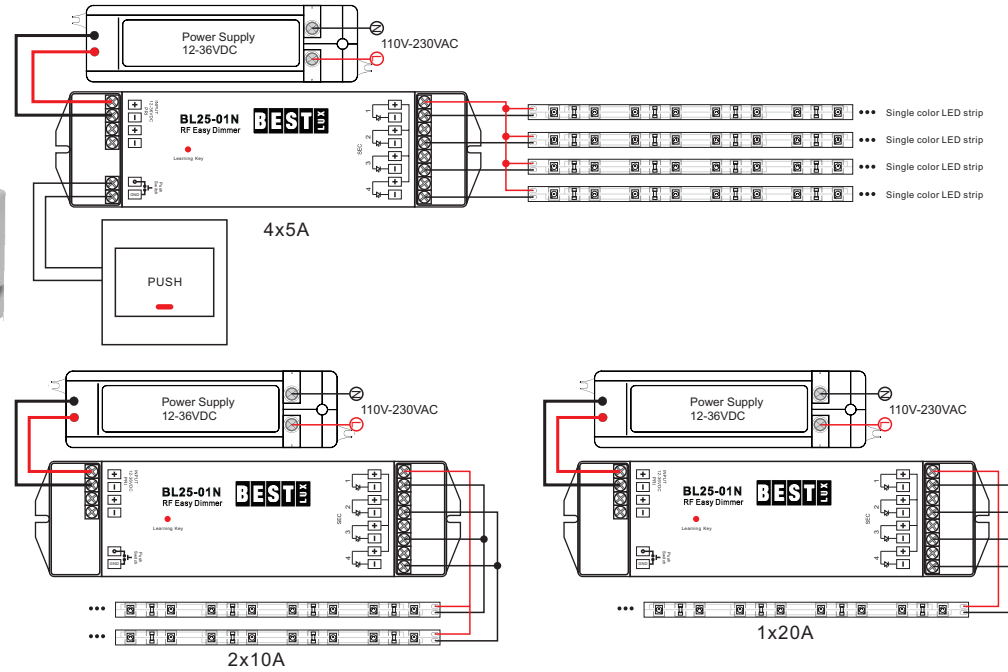



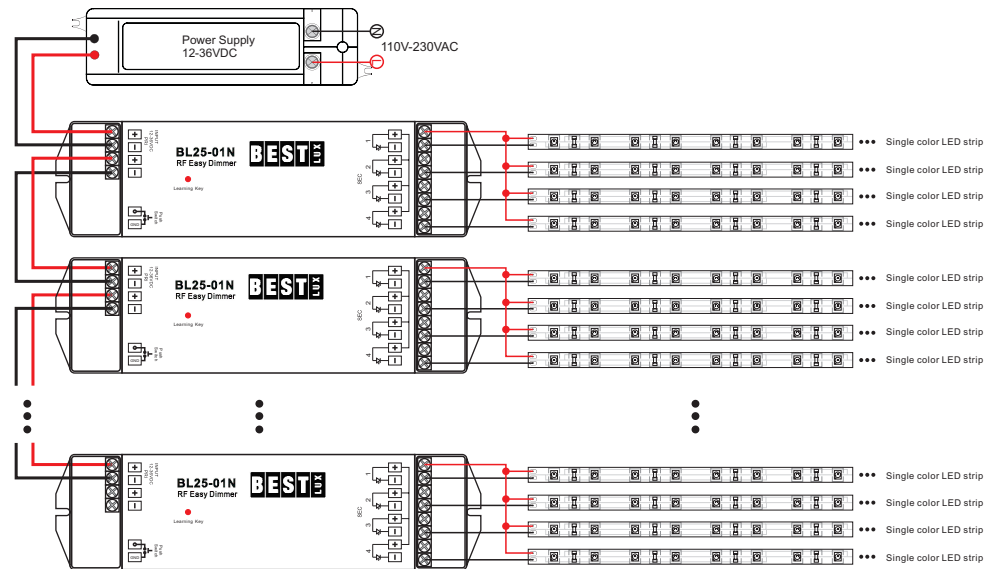





2)Receiver Connection Diagram for Multiple Units



Operation

After you have wired all the receivers according to Figure illustration you need to do the following:

1. Pull off the plastic film cover of the battery at the back of remote.
2. Pair remote and receiver: short press the Learning Key on the receiver, then immediately short press the  or . Once you do that, the LED lights will blink once. Now your remote and receiver are paired! Do the same for the other receivers if you use them, you can add as many optional receivers as you wish.
3. Press  and  can dim 4 channels brightness independently.
Long press  : dim brightness from 0.1%-100%.
long press  : dim brightness from 100%-0.1%.
 and  switch on/off 4 channel together.

Memory Reset:

In case you want to reset the memory of the receiver, press the learning function button for 10 seconds while the unit is being powered. The unit will then reset to factory defaults.

4 channels remote

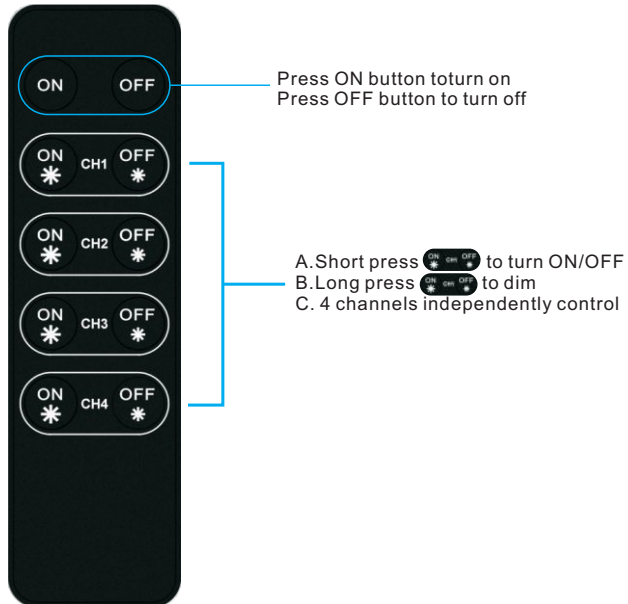

Safety & Warnings

- 1) The product shall be installed and serviced by a qualified person.
- 2) IP20. Please avoid the sun and rain. When installed outdoors, please ensure it is mounted in a water proof enclosure.
- 3) Always be sure to mount this unit in an area with proper ventilation to avoid overheating.
- 4) Please check if the output voltage of any LED power supplies used comply with the working voltage of the product.
- 5) Never connect any cables while power is on and always assure correct connections to avoid short circuits before switching on.
- 6) Please ensure that the cable is secured tightly in the connector
- 7) For update information please consult your supplier.

Warranty Agreement

- 1) We provide lifelong technical assistance with this product:
 - 2-year warranty. We print date on every products, for example :1125 means year 2011, week 25. The warranty is for free repair or replacement and covers manufacturing faults only.
 - For faults beyond the 2-year warranty we reserve the right to charge for time and parts.
- 2) Limited Warranty
 - Any defects caused by wrong operation.
 - Any damages caused by unauthorized removal, maintenance, modifying, incorrect connection and replacement of chips.
 - Any damages due to transportation, vibration etc. after purchase.
 - Any damages caused by earthquake, fire, lightning, pollution and abnormal voltage.
 - Any damages caused by negligence, inappropriate storing at high temperatures and humidity or near harmful chemicals.
 - Product has been updated
- 3) Repair or replacement as provided under this warranty is the exclusive remedy to the customer.