

### Product Description

Nexto Series is a powerful and complete Programmable Logic Controller (PLC) with unique and innovative features. Due to its flexibility, smart design, enhanced diagnostics capabilities and modular architecture, Nexto can be used for control systems from medium to high-end large applications or in machinery with high performance requirements.

Nexto Series has a wide range of digital I/O modules which were designed to fit requirements in different kinds of applications providing high-density I/O modules. NX2020 is a relay output module designed. NX2020 offers 16 source type protected relay outputs for general purpose use. NX2020 uses two positions in the Nexto Series rack. In addition it has some exclusive features brought by Nexto Series like Electronic Tag on Display™, Easy Plug System™ and One Touch Diag™.



Its main features are:

- High density, with 16 outputs in a compact module
- Two isolated output groups
- Protection against power supply polarity inversion
- External power supply low voltage diagnostic
- Display for module diagnostics and output state indication
- Easy Plug System™
- One Touch Diag™
  
- Electronic Tag on Display™

### Ordering Information

#### Included Items

The product package contains the following items:

- NX2020 module
- Two 10-terminals connector with wire holder
- Installation guide

#### Product Code

The following code should be used to purchase the product:

Code	Description
NX2020	24 Vdc 16 DO Relay Module

#### Related Products

The following product must be purchased separately when necessary:

Code	Description
NX9402	10-terminal connector with wire holder

### Innovative Features

Nexto Series brings to the user several innovations in utilization, supervision and system maintenance. These features were developed focusing a new experience in industrial automation. The list below shows some new features that the user will find in NX2020 module:



**Easy Plug System™:** Nexto Series has an exclusive method to plug and unplug I/O connectors. The entire connector can be easily removed with a single movement and with no special tools or huge effort.



**One Touch Diag™:** One Touch Diag is an exclusive feature that Nexto Series brings to PLCs. With this new concept, the user can check diagnostic information of any module present in the system directly on CPU's graphic display with one single press in the diagnostic switch of the respective module. OTD is a powerful diagnostic tool that can be used offline (without supervisor or programmer), reducing maintenance and commissioning times.





**ETD – Electronic Tag on Display™:** Another exclusive feature that Nexto Series brings to PLCs is the Electronic Tag on Display. This new functionality makes the process of checking the tag names of any I/O terminal or module used in the system directly on the CPU's graphic display. Along with this information, the user can check the description, as well. This feature is extremely useful during maintenance and troubleshooting procedures.

**DHW – Double Hardware Width™:** Nexto Series modules were designed to save space in user cabinets or machines. For this reason, Nexto Series delivers two different module widths: Double Width (two backplane rack slots are required) and Single Width (only one backplane rack slot is required). This concept allows the use of compact I/O modules with a high-density of I/O points along with complex modules, like CPUs, fieldbus masters and power supply modules.



**iF Product Design Award 2012:** Nexto Series was the winner of iF Product Design Award 2012 in industry + skilled trades group. This award is recognized internationally as a seal of quality and excellence, considered the Oscars of the design in Europe.

### Product Features

	NX2020
Backplane rack occupation	2 sequential slots
Output type	Relay output NO type
Number of outputs	16
Drive capacity for resistive load	2 A @ 30 Vdc 2 A @ 250 Vac
Maximum drive capacity per output group	4 A
Minimum load	100 $\mu$ A
Expected lifetime	10 <sup>5</sup> operations for resistive loads
Maximum contact resistance	100 m $\Omega$
Switching time	Up to 7 ms (on-to-off transition) Up to 12 ms (off-to-on transition)
Maximum switching frequency	1 Hz
Configurable parameters	Yes, output behavior with CPU in STOP mode
Output state indication	Yes
One Touch Diag (OTD)	Yes
Electronic Tag on Display (ETD)	Yes
Status and diagnostic indication	Display, web pages and CPU's internal memory
Hot swap capability	Yes
Module protections	Yes, power supply polarity inversion protection, protection against surge voltages and against short circuit
Isolation	
Output group to output group	1000 Vac / 1 minute
Output to logic	2500 Vac / 1 minute
Output to protective earth 	500 Vac / 1 minute
Logic to protective earth 	1250 Vac / 1 minute
External power supply to outputs/ common terminal	1250 Vac / 1 minute
Current consumption from backplane rack power supply	230 mA
External power supply	19.2 to 30 Vdc
External power supply current	140 mA @ 24 Vdc
Maximum power dissipation	6 W
IP level	IP 20
Operating temperature	0 to 60 °C
Storage temperature	-25 to 75 °C
Operating and storage relative humidity	5 to 96 %, non-condensing
Conformal coating	Yes
Standards	IEC 61131-2 CE, Electromagnetic Compatibility (EMC) and Low-Voltage Directive (LVD)   RoHS 2002/95/EC
Module dimensions (W x H x D)	36 x 114.63 x 115.30 mm

<b>Package dimensions (W x H x D)</b>	44.00 x 122.00 x 147.00 mm
<b>Weight</b>	250 g
<b>Weight with package</b>	300 g

### Notes

**Output type:** NX2020 provides 16 relay outputs. The first eight outputs (00 to 07) use the same common terminal (terminal 9 of the connector A) and the last eight outputs (10 to 17) use another common terminal (terminal 9 of the connector B). More information can be found at Installation.

**Time Switching:** The switching time is the sum of the module update time plus relay update time regarding the respective output. The maximum module update time is 2 ms. The maximum relay update time (on-off) is 5 ms and the maximum relay update time (off-on) is 10 ms.

**Maximum drive capacity per output group:** The sum of all loads of a given group must not exceed the defined Maximum drive capacity per output group.

**External power supply:** NX2020 requires an external power supply used to supply the module's relays. The external power supply must be connected to terminal 10 of the connector A and B. More information can be found at Installation.

**External power supply current:** Power supply current is the maximum current that can be drained from the external power supply.

**Switching frequency:** The switching frequency is the maximum frequency that can be used in the NX2020's outputs.

**Conformal coating:** Conformal coating protects the electronic components inside the product from moisture, dust and other harsh elements to electronic circuits.

## Installation

### Electrical Installation

The figure below shows an example where each NX2020 output is connected to one load. The outputs 00 and 07 are supplied by a power supply and the outputs 10 a 17 are supplied by a different one.

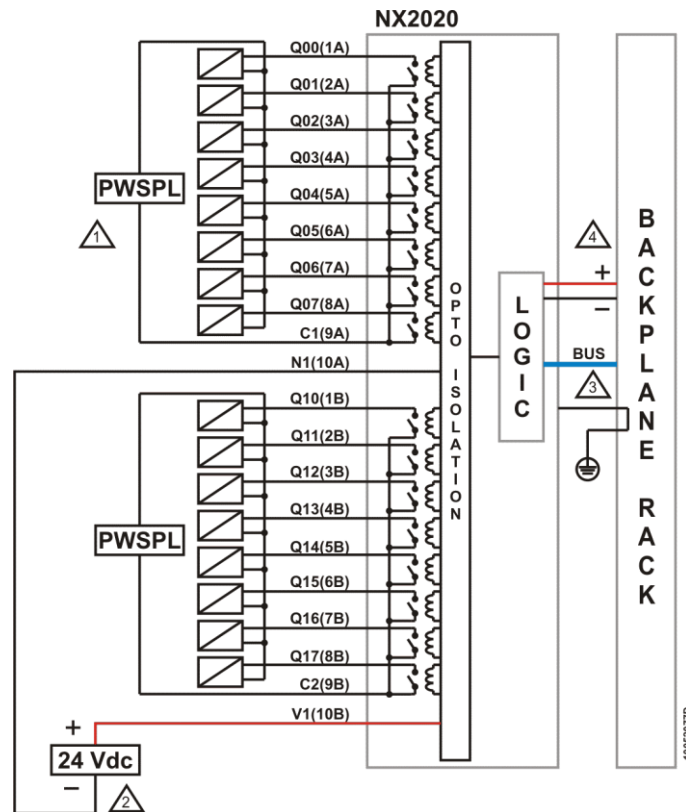

### Diagram Notes

- 1 – Typical usage of source digital outputs.
- 2 – External power supply to supply the outputs, V1 is connected to +24 Vdc and N1 is connected to 0 Vdc.
- 3 – The module is grounded through the Nexto Series backplane racks.
- 4 – The module power supply is derived from the connection to the backplane rack, not requiring external connections.

### Connector Pinout

The following figure indicates the connector A and the connector B.

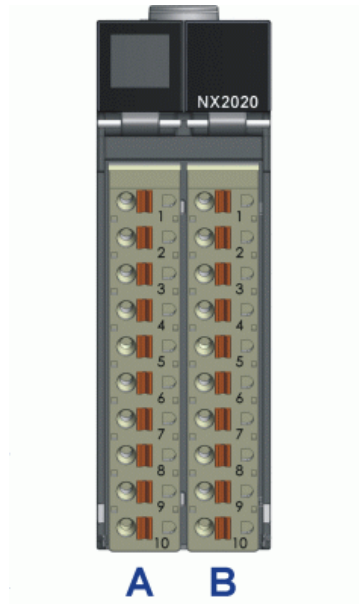

The following table shows the description of each connector terminal.

Terminal Number	Connector A Description	Connector B Description
1	Output 00	Output 10
2	Output 01	Output 11
3	Output 02	Output 12
4	Output 03	Output 13
5	Output 04	Output 14
6	Output 05	Output 15
7	Output 06	Output 16
8	Output 07	Output 17
9	Common for outputs 00 to 07	Common for outputs 10 to 17
10	(N1) 0 Vdc	(V1) + 24 Vdc

### Suppressor Circuit

For further information about suppressor circuit, consult Nexto Series User Manual - MU214600.

#### ATTENTION:

Atmospheric discharges (thunders) may cause damages to the modules although it's protections. Additional protections should be used if module's power comes from a power supply located outside the cabinet where the module is installed, because it could be vulnerable to this kind of discharges. If the field wiring of the output points is susceptible to this kind of discharge, surge suppressors should be used.

### Mechanical and Electrical Assembly

The mechanical and electrical mounting and the connector insertion and removing for I/O modules are described at Nexto Series User Manual – MU214600.

### Compatibility with Other Products

The following table provides information regarding the compatibility of the module NX2020 and Nexto Series programming tool MasterTool IEC XE.

NX2020		Software Version Compatible
Version	Revision	MasterTool IEC XE
1.0.0.0	AA	1.22 or higher
1.0.1.1 or higher	AB or higher	1.29 or higher

### Notes

**Product review:** If the software is upgraded in the field the product reviewing indicated on the label will no longer match the actual review of the product.

## Physical Dimensions

Nexto Series User Manual - MU214600 should be consulted for general measurement of installation panel.

Dimensions in mm.

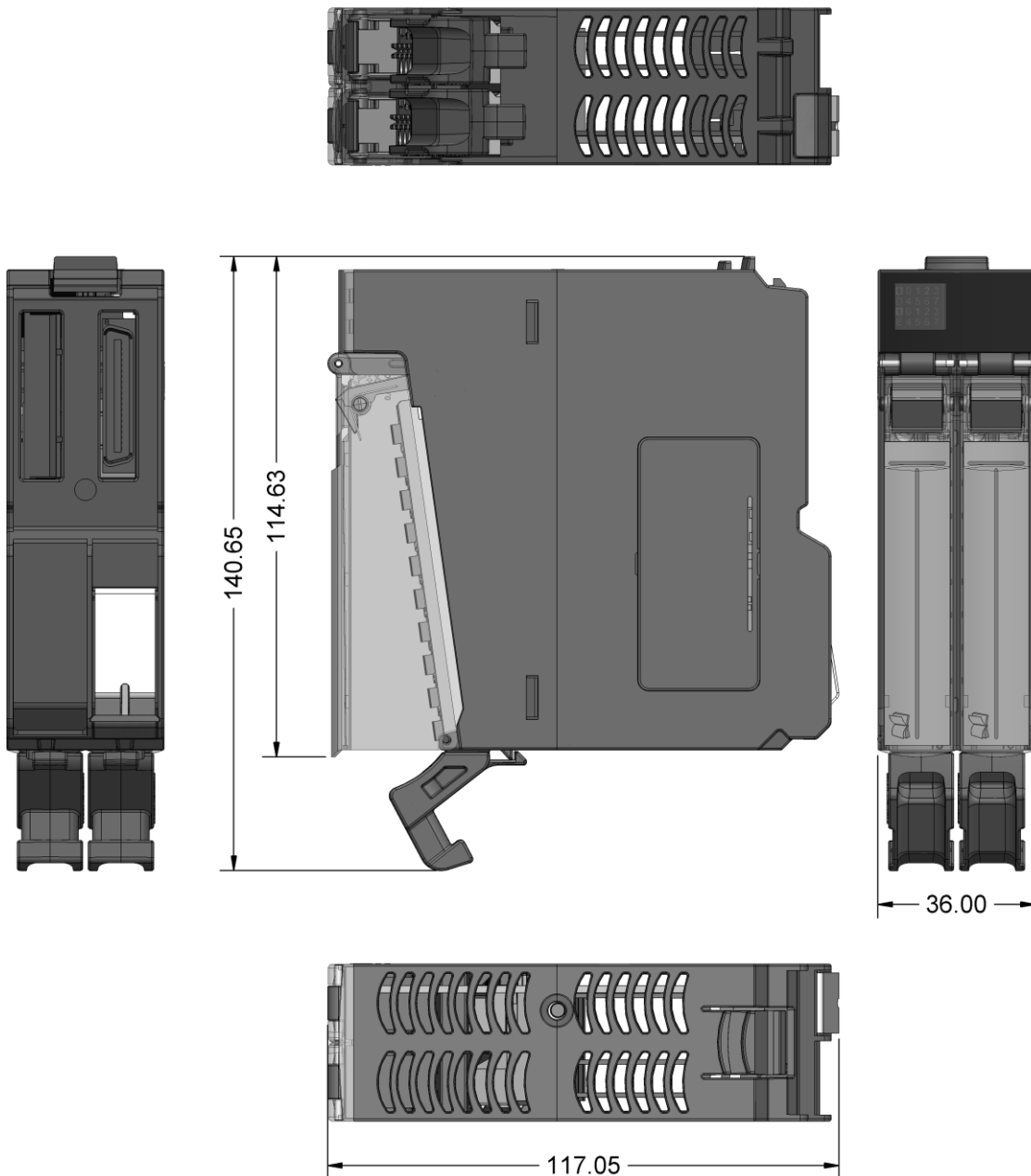

09091457C

## Configuration

NX2020 was developed to be used with Nexto Series products. All Nexto Series products configurable in MasterTool IEC XE. All configuration data of a given module can be accessed through a double click in the desired module on the graphical editor.

## Process Data

Process Data, when available, are the variables that are used to access and control NX2020. The list below describes all variables delivered by NX2020.

The process data of the module, when inserted in a PROFIBUS network, can be accessed through variables. The table below presents the variables organizational structure in the UCP memory.

Besides this data, NX2020 also provides a set of variables containing information related to diagnostics which are also described in this document.

Variable	Size	Process Data	Description	Type	Update
%QB(n)	BYTE	Digital Outputs Byte-0	Output value of channel 00 to 07	Output (Read/ Write)	Always
%QB(n+1)	BYTE	Digital Outputs Byte-1	Output value of channel 10 to 17	Output (Read/ Write)	Always

### Notes

**Update:** The field Update indicates if, by default, the respective process data is updated by CPU and NX2020. When defined as Always, it means that the process data is always updated. When defined as Selectable, it means that the user can select if the respective process data will be updated or not. All these process data are exchanged between CPU and NX2020 through the bus. To improve CPU performance, it's recommended to update only the process data that will be used in the application.

## Modules Parameters

Name	Description	Standard value
Output Behavior on CPU STOP Mode – Group 0	This parameter is individually defined for each output and defines the behavior of each output when CPU is in STOP mode	False
Output Behavior on CPU STOP Mode – Group 1	This parameter is individually defined for each output and defines the behavior of each output when CPU is in STOP mode	False
User Defined Output Value – Group 0	This parameter defines the value of each output when CPU is in STOP mode and when output behavior with CPU in STOP mode is set	False
User Defined Output Value – Group 1	This parameter defines the value of each output when CPU is in STOP mode and when output behavior with CPU in STOP mode is set	False
%Q Start Address of Module Diagnostics	Defines the start address of the module diagnostics	-

### Notes

**Output Behavior on CPU STOP Mode – Group 0 and 1:** This is the behavior of the outputs when CPU is in STOP mode. During procedures of CPU in exception, Reset Warm, Reset Cold, Reset Origin or Power Failure this behavior may be in effect while CPU is changing through internal states. If module is hot-swapped with CPU in STOP mode, the output behavior will not be in effect. After downloading a project with different behavior settings, the new settings will only be updated only on CPU RUN state.

## Module Usage

### General Purpose Outputs Write

NX2020 has two variables to control its outputs (Digital Outputs Byte 0 and Digital Outputs Byte 1). These variables have eight bits where each bit represents the output logical state of each output channel. The relationship between each bit and its respective output can be found on the Bus I/O Mapping tab.



## Maintenance

Altus recommends that all modules' connections should be checked and any dust or any kind of dirt at the module's enclosure should be removed at least every 6 months.

NX2020 offers five important features to assist users during maintenance: Electronic Tag on Display, One Touch Diag, Status and Diagnostics Indicators, Web Page with Complete Status and Diagnostics List and Diagnostics Mapped to Variables.





### Electronic Tag on Display and One Touch Diag

Electronic Tag on Display and One Touch Diag are important features that provide to the user the option to check the tag, description and diagnostics related to a given module directly on the CPU display.

Electronic Tag on Display and One Touch Diag are easy-to-use features. To check the tag and diagnostics of a given module, it's required only one short press on its diagnostic switch. After pressing once, CPU will start to scroll tag information and diagnostics information of the module. To access the respective module description, just long press (longer than 1 s) the diagnostic switch of the respective module.

More information about Electronic Tag on Display can be found at Nexto Series CPUs Utilization Manual – MU214605.

### Status and Diagnostics Indicators

Nexto I/O modules have a display with the following symbols: D, E, ,  and numerical characters. The states of the symbols D, E, ,  are common for all Nexto Series modules. These states can be consulted in the table below.

The meaning of the numerical characters can be different for specific modules. In case of digital output modules, the numerical characters show the respective logic output state. When the numerical character is on, its respective output is also on and if the numerical character is off, the respective output is also off. The relationship between the output number and its respective numerical character can be found on the following figure.

#### D and E States

D	E	Description	Cause	Solution	Priority
Off	Off	Display fail or module off	-	Check if the module is completely connected to the backplane rack and if the backplane rack is supplied by an external power supply	-
On	Off	Normal use	-	-	9 (Lower)
Blinking 1x	Off	Active Diagnostic	There is at least one active diagnostic related to the module NX2020	Check what the active diagnostic is. More information can be found at Diagnostics Mapped to Variables section of this document	8
Blinking 2x	Off	CPU in STOP mode . If the module is in a Remote PROFIBUS, Master is in Clear state.	-	Check if CPU is in RUN mode or if PROFIBUS Master is in OPERATE mode. More information can be found on CPU's or PROFIBUS Master's documentation	7
Blinking 3x	Off	Reserved	-	-	6
Blinking 4x	Off	Non-Fatal Fault	Failure in some hardware or software component, which does not have impact on the basic functionality of the product	Check the module diagnostic information. If it is a hardware fault, provide the replacement of this part. If it is a software fault, please contact the Technical Support	5

Off	Blinking 1x	Parameterization error	NX2020 isn't parameterized or didn't receive the new parameterization	-	4
Off	Blinking 2x	Loss of master	Loss of communication between module and CPU or module and PROFIBUS head.	Check if the module is completely connected to the backplane rack Check if CPU is in RUN mode or if PROFIBUS head is Active.	3
Off	Blinking 3x	Reserved	-	-	2
Off	Blinking 4x	Fatal hardware fault	-	-	1 (Higher)

### 0, 1 and Numerical Characters

The segments 0 and 1 are used to group the numerical characters used for the 16 outputs. The numerical characters that are placed at the right side of character 0 represent the outputs from 00 to 07, where character 0 is related to output 00 and character 7 is related to output 07. In the same way the numerical characters that are placed at the right side of character 1 represent the outputs from 10 to 17 where character 0 is related to output 10 and character 7 is related to output 17. The figure below shows the relationship between numerical characters and the respective outputs.

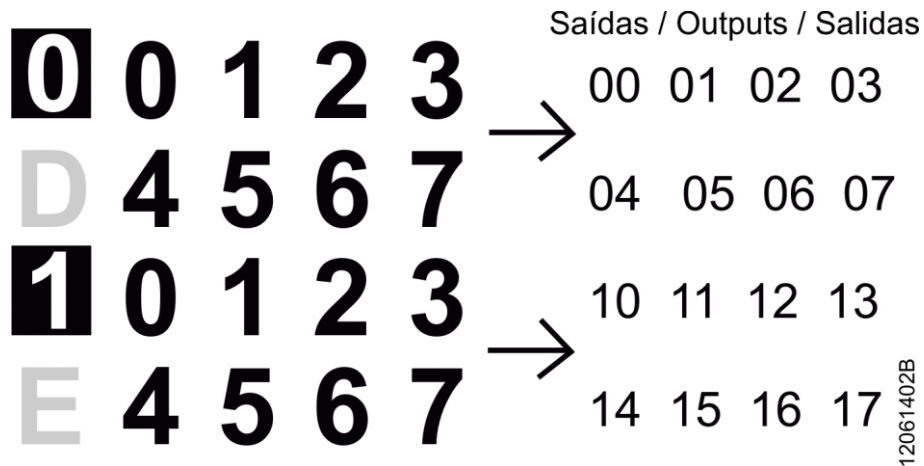

### Web Page with Complete Status and Diagnostics List

Another way to access diagnostics information on Nexto Series is via web pages. Nexto Series CPU's has an embedded web page server that provides all Nexto status and diagnostics information, which can be accessed using a browser. More information about web page with complete status and diagnostics list can be found at Nexto Series CPUs User Manual – MU214605.

### Diagnostics Mapped to Variables

All NX2020's diagnostics can be accessed through variables that can be handled by the user application or even forwarded to a supervisory system using a communication channel. There are two different ways to access diagnostics in the user application: using symbolic variable with AT directive or direct representation variable. Altus recommends the use of symbolic variables. The table below shows all available diagnostics for NX2020 and their respective memory addresses, descriptions, symbolic variable and string that will be shown on the CPU graphical display and web.

### General Diagnostics

Direct Representation Variable		Diagnostic Message	Symbolic Variable DG_modulename.tGeneral.	Description	PROFIBUS S Message Code
Variable	Bit				
%QB(n)	0..7	Reserved			
%QB(n+1)	0	MODULE W/ DIAGNOSTIC	bActiveDiagnostics	TRUE – Module has active diagnostics	-
		NO DIAG		FALSE – Module doesn't have active diagnostic	
	1	MODULE W/ FATAL ERROR	bFatalError	TRUE – Fatal error	25
		-		FALSE – No fatal error	
	2	CONFIG. MISMATCH	bConfigMismatch	TRUE – Parameterization error	26
		-		FALSE – Parameterization ok	
	3	WATCHDOG ERROR	bWatchdogError	TRUE – Watchdog has been detected	27
		-		FALSE – No watchdog	
	4	OTD SWITCH ERROR	bOTDSwitchError	TRUE – Module has switch failure	28
		-		FALSE – Diagnostics switch ok	
	5..7	Reserved			

### Detailed Diagnostics

Direct Representation Variable		Diagnostic Message	Symbolic Variable DG_modulename.tDetailed.	Description	PROFIBUS S Message Code
Variable	Bit				
%QB(n+2)	0..7	Reserved			
%QB(n+3)	0	NO EXTERNAL SUPPLY	bNoExternalSupply	TRUE – No external voltage	24
		-		FALSE – Power supply ok	
1..7	Reserved				

#### Notes

**Direct Representation Variable:** "n" is the address defined in the field %Q Start Address of Diagnostic on the NX2020's configuration screen – Modules Parameters tab in the MasterTool IEC XE.

**Symbolic Variable:** Some symbolic variables serve to access diagnostics. These diagnostics are stored into the direct representation variables, then the AT directive is used to map the symbolic variables in the direct representation variables. The directive AT is a reserved word in the MasterTool IEC XE, that uses this directive to declares the diagnostics automatically on symbolic variables. All diagnostics automatically mapped in symbolic variables can be found in the Diagnostics object.

### Hot Swap

This product supports hot swap. For further information about how to correctly perform a hot swap, consult Nexto Series User Manual - MU214600.

### Manuals

For further technical details, configuration, installation and programming of Nexto Series the table below should be consulted.

The table below is only a guide of some relevant documents that can be useful during the use, maintenance, and programming of NX2020. The complete and updated table containing all documents of Nexto Series can be found at Nexto Series User Manual – MU214600.

Document Code	Description	Language
<b>CE114000</b>	Nexto Series – Technical Characteristics	English
<b>CT114000</b>	Série Nexto – Características Técnicas	Portuguese
<b>CS114000</b>	Serie Nexto – Especificaciones y Configuraciones	Spanish
<b>MU214600</b>	Nexto Series User Manual	English
<b>MU214000</b>	Manual de Utilização Série Nexto	Portuguese
<b>MU214300</b>	Manual Del Usuario Serie Nexto	Spanish
<b>MU214605</b>	Nexto Series CPUs User Manual	English
<b>MU214100</b>	Manual de Utilização UCPs Série Nexto	Portuguese
<b>MU214305</b>	Manual del Usuario UCPs Serie Nexto	Spanish
<b>MU299609</b>	MasterTool IEC XE User Manual	English
<b>MU299048</b>	Manual de Utilização MasterTool IEC XE	Portuguese
<b>MU299800</b>	Manual Del Usuário MasterTool IEC XE	Spanish