

PCM DECODING

PREPARATION	110
signal source	110
clock synchronization.....	110
frame synchronization.....	110
companding	111
PCM decoding.....	111
the TMS PCM DECODER module	112
EXPERIMENT	113
the transmitter (encoder)	113
the receiver (decoder).....	114
a DC message.....	114
a periodic message	115
message reconstruction	116
companding.....	117
frame synchronization	117
TUTORIAL QUESTIONS	118
APPENDIX.....	119
automatic frame synchronization	119

PCM DECODING

ACHIEVEMENTS: *decoding of a PCM signal. Determination of the quantizing scheme used at the encoder. Message reconstruction. Introduction to companding; comparison of 7-bit linear with 4-bit companded PCM.*

PREREQUISITES: *completion of the experiment entitled **PCM encoding** in this Volume. An appreciation of the principles of companding.*

ADVANCED MODULES: *A PCM ENCODER and a PCM DECODER (version 2 preferable).*

PREPARATION

signal source

The signal to be decoded¹ in this experiment will be provided by you, using the PCM ENCODER module as set up in the experiment entitled *PCM encoding*. The format of the PCM signal is described there. You should have already completed that experiment.

clock synchronization

A clock synchronization signal will be stolen from the encoder.

frame synchronization

automatic

In the PCM DECODER module there is circuitry which automatically identifies the location of each frame in the serial data stream. To do this it collects groups of eight data bits and looks for the repeating pattern of alternate ones and zeros placed there (embedded) by the PCM ENCODER in the LSB position.

It can be shown that such a pattern cannot occur elsewhere in the data stream provided that the original bandlimited analog signal is sampled at or below the Nyquist rate.

¹ it is common practice to refer to messages being *demodulated* from analog signals, and *decoded* from digital signals.

When the embedded pattern is found an ‘end of frame’ synchronization signal FS is generated, and made available at the front panel.

The search for the frame is continuously updated. Why ?

Under noisy conditions (not relevant for this particular experiment) the reliability of the process will depend upon the size of the group of frames to be examined. This can be set by the on-board switch SW3 of the PCM DECODER module. See *Table A-1* in the Appendix to this experiment for details.

stolen

Frame synchronization can also be achieved, of course, by ‘stealing’ the synchronization signal, FS, from the PCM ENCODER module. Use of this signal would assume that the clock signal to the PCM DECODER is of the correct phase. This is assured in this experiment, but would need adjustment if the PCM signal is transmitted via a bandlimited channel (see Tutorial Question 0). Hence the embedded frame synchronization information.

companding

You should prepare by reading something about the principles of *companding*. You will already be aware that the PCM ENCODER module can incorporate compression into its encoding scheme. The PCM DECODER module can introduce the complementary expansion. The *existence* of these characteristics will be confirmed, but their *effectiveness* in intelligibility enhancement (when speech is the message) is not examined.

PCM decoding

The PCM DECODER module is driven by an external clock. This clock signal is synchronized to that of the transmitter. For this experiment a ‘stolen’ clock will be used. The source of frame timing information has been discussed above.

Upon reception, the PCM DECODER:

1. extracts a frame synchronization signal FS from the data itself (from the embedded alternate ones and zeros in the LSB position), or uses an FS signal stolen from the transmitter (see above).
2. extracts the binary number, which is the coded (and quantized) amplitude of the sample from which it was derived, from the frame.
3. identifies the quantization level which this number represents.
4. generates a voltage proportional to this amplitude level.
5. presents this voltage to the output V_{out} . The voltage appears at V_{out} for the duration of the frame under examination.
6. message reconstruction can be achieved, albeit with some distortion, by lowpass filtering. A built-in reconstruction filter is provided in the module.

encoding

At the encoder the sample-and-hold operation (before encoding) is executed periodically. It produces a rectangular pulse form². Each pulse in the waveform is of *exactly* the same amplitude as the message *at the sampling instant*.

But *it is not possible* to recover a *distortionless* message from these samples. They are *flat top*, rather than *natural* samples.

Call this the sampling distortion.

At the encoder the amplitude of this waveform was then *quantized*. It is still a rectangular pulsed waveform, but the amplitude of each pulse will, in general, be in error by a small amount. Call this waveform $s(t)$.

This was examined in the experiment entitled *Sampling with SAMPLE & HOLD* (in this Volume), to which you should refer.

decoding

The voltage at V_{out} of the decoder is *identical with* $s(t)$ above. The decoder itself has introduced no distortion of the received signal.

But $s(t)$ is already an inexact version of the sample-and-hold operation at the encoder. This will give rise to *quantization distortion* as well as the *sampling distortion* already mentioned.

You should read about these phenomena in a Text book.

the TIMS PCM DECODER module

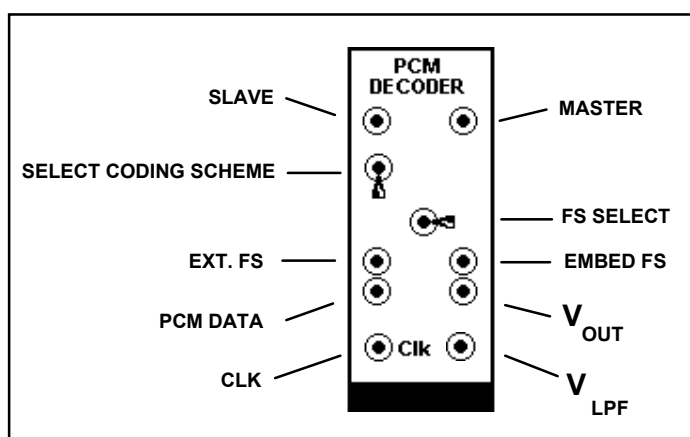

Figure 3: front panel layout of the PCM DECODER

A TIMS PCM DECODER module will be used for decoding.

The front panel of this module is shown in Figure 3. Technical details are described in the *TIMS Advanced Modules User Manual*.

² if the sample is held for as long as the sampling period, it is a stepped waveform. If the sample is held for a shorter time it is a rectangular waveform (or pulseform). It need only be held long enough for the quantizer to make its decision about which of the available (quantized) amplitudes to allocate to the sample.

Note and understand the purpose of the input and output connections, and the toggle switches. Counting from the top, these are:

- **SLAVE:** not used during this experiment. Do *not* connect anything to this input.
- **MASTER:** not used during this experiment. Do *not* connect anything to this output.
- **SELECT CODING SCHEME:** a three position toggle which selects the coding scheme used by the signal to be decoded
- **FS SELECT:** a two-position toggle switch which selects the method of obtaining the frame synchronization signal (FS) either external at (EXT.FS), or derived internally from the embedded information in the received PCM itself (EMBED FS).
- **EXT. FS:** connect an external frame sync. signal here if this method of frame synchronization is to be used.
- **EMBED FS:** if the frame synch. signal is derived internally from the embedded information, it is available for inspection at this output.
- **PCM DATA:** the PCM signal to be decoded is connected here.
- **V_{OUT}:** the decoded PCM signal.
- **CLK:** this is a TTL (red) input, and serves as the MASTER CLOCK for the module. Clock rate must be 10 kHz or less. For this experiment you will use the 8.333 kHz TTL signal from the MASTER SIGNALS module.

EXPERIMENT

the transmitter (encoder)

A suitable source of PCM signal will be generated using a PCM ENCODER module. This module was examined in the experiment entitled *PCM encoding*.

You should set it up before patching up the demodulator.

T1 before plugging in PCM ENCODER module, set the toggles of the on-board SYNC MESSAGE switch SW2. Set the left hand toggle DOWN, and the right hand toggle UP. This selects a 130 Hz sinusoidal message, which will be used later. Now insert the module into the TIMS system.

T2 use the 8.333 kHz TTL signal from the MASTER SIGNALS module for the CLK.

T3 select, with the front panel toggle switch, the 4-bit LINEAR coding scheme.

T4 synchronize the oscilloscope 'externally' to the frame synchronization signal at FS. Set the sweep speed to 0.5 ms/cm (say). This should show a few frames on the screen.

T5 connect CH1-A of the SCOPE SELECTOR to the PCM OUTPUT of the PCM ENCODER.

T6 we would like to recognise the PCM DATA out signal. So choose a 'large' negative DC for the message (from the VARIABLE DC module). From previous work we know the corresponding code word is '0000', so only the embedded alternating '0' and '1' bits (for remote FS) in the LSB position should be seen. Confirm this. They should be 1920 ms apart. Confirm this both by measurement and calculation !

T7 vary the DC output and show the appearance of new patterns on CH1-A. When finished, return the DC to its maximum negative value (control fully anti-clockwise).

The PCM signal is now ready for transmission. In a later experiment the PCM signal will be sent via a noisy, bandlimited channel. For the present it will be connected directly to a TIMS PCM DECODER module.

the receiver (decoder)

T8 use the front panel toggle switch to select the 4-bit LINEAR decoding scheme (to match that of the transmitter)

T9 'steal' an 8.333 kHz TTL clock signal from the transmitter and connect it to the CLK input.

T10 in the first instance 'steal' the frame synchronization signal FS from the transmitter by connecting it to the frame synchronization input FS of the receiver. At the same time ensure that the FS SELECT toggle switch on the receiver is set to EXT. FS.

T11 ensure both channels of the oscilloscope are set to accept DC; set their gains to 1 volt/cm. With their inputs grounded set their traces in the centre of their respective halves of the screen. Remove the grounds.

T12 connect CH2-A to the sample-and-hold output of the PCM DECODER.

!

a DC message

You are now ready to check the overall transmission from transmitter input to decoder output. The message is a DC signal.

T13 connect the PCM DATA output signal from the transmitter to the PCM DATA input of the receiver.

T14 slowly vary the DC output from the VARIABLE DC module back and forth over its complete range. Observe the behaviour of the two traces. The input to the encoder moves continuously. The output from the decoder moves in discrete steps. These are the 16 amplitude quantizing steps of the PCM ENCODER.

You are observing the source of quantizing noise. The output can take up only one of 16 predetermined values.

T15 draw up a table relating input to output voltages.

You can now see the number of quantizing levels at the transmitter, and their values.

T16 compare the quantizing levels just measured with those determined in the experiment entitled **PCM encoding**.

T17 reset the coding scheme on both modules to 7-bit. Sweep the input DC signal over the complete range as before. Notice the 'granularity' in the output is almost un-noticeable compared with the 4-bit case. There are now 2^7 rather than 2^4 steps over the range.

a periodic message

It was not possible, when examining the PCM ENCODER in the experiment entitled *PCM encoding*, to see the sample-and-hold waveform within the *encoder*. But you have just been looking at it (assuming perfect decoding) at the output of the *decoder*.

With a periodic message its appearance may be more familiar to you.

T18 change to a periodic message³ by connecting the SYNC MESSAGE of the PCM ENCODER, via a BUFFER AMPLIFIER, to its input V_{in} . An amplitude of $2 V_{pp}$ is suitable. Slow down the oscilloscope sweep speed to 1 ms/cm. Observe and record the signal at CH2-A.

When you agree that what you see is what you expected to see, prepare to make a change and predict the outcome.

³ the message was set up in Task 1 to be a 130 Hz sinewave, synchronized to the sampling rate

Currently the encoding scheme is generating a 4-bit digital word for each sample.

What would be the change to the waveform, now displaying on CH2-A, if, at the encoder, the coding scheme was changed from 4-bit to 7-bit ?

Sketch your answer to this question - show the waveform *before* and then *after* the change.

T19 *change the coding scheme from 4-bit to 7-bit. That is, change the front panel toggle switch of **both** the PCM ENCODER **and** the PCM DECODER from 4-bit to 7-bit. Observe, record, and explain the change to the waveform on CH2-A.*

When satisfied, proceed.

message reconstruction

You can see, qualitatively, that the output is related to the input. The message could probably be recovered from this waveform. But it would be difficult to predict with what accuracy.

Lowpass filtering of the waveform at the output of the decoder will reconstruct the message, although theory shows that it will not be perfect. It will improve with the number of quantizing levels.

What amplitude characteristic is required for the reconstruction filter ? See Tutorial Question Q3.

If any distortion components are present they would most likely include harmonics of the message. If these are to be measurable (visible on the oscilloscope, in the present case), then they must not be removed by the filter and so give a false indication of performance. Recall the experiment entitled *Amplifier overload* (within *Volume A2 - Further & Advanced Analog Experiments*).

So we could look for harmonics in the output of the filter. But we do not have conveniently available a spectrum analyzer.

An alternative is to use a two-tone test message. Changes to its shape (especially its envelope) are an indication of distortion, and are more easily observed (with an oscilloscope) than when a pure sinewave is used. It will be difficult to make one of these for this experiment, because our messages have been restricted to rather low frequencies, which are outside the range of most TIMS modules.

But there is provided in the PCM ENCODER a message with a shape slightly more complex than a sinewave. It can be selected with the switch SW2 on the encoder circuit board. Set the left hand toggle UP, and the right hand toggle DOWN. See the Appendix to the experiment entitled *PCM encoding* for more details.

A message reconstruction LPF is installed in the PCM DECODER module (version 2 and above). If you do not have such a module then bypass the next two Tasks.

T20 *change to the complex message from the PCM ENCODER as described above.*

T21 include the built-in LPF in the output of the PCM DECODER, and observe the reconstructed message. Make comparisons between the 4-bit linear and the 7-bit linear coding schemes. Try different message amplitudes into the PCM ENCODER. Can you observe any distortion? Record your observations.

If you think the LPF itself might have introduced some distortion, you could check by connecting the complex message to its input direct, and observing the output.

companding

It is now time to verify the companding algorithm installed in the encoder.

T22 use the front panel toggle switches (on both modules) to select 4-bit companding. Use both 'low' and 'high' level messages into the PCM ENCODER. Check the quantizing characteristic. Record your observations and comment upon them.

Because of the speed limitations of the PCM modules it is not possible to use speech as the message, and so to observe the effects of companding. The effective bandwidth of the system is not wide enough.

See Tutorial Question Q7.

frame synchronization

In all of the above work the frame synchronization signal FS has been stolen from the encoder (as has been the clock signal). This was not necessary.

The PCM ENCODER has circuitry for doing this automatically. It looks for the alternating '0' and '1' pattern embedded as the LSB of each frame. It is enabled by use of the FS SELECT front panel toggle switch. Currently this is set to EXT FS.

T23 change the FS SELECT switch on the front panel of the PCM DECODER module from EXT FS to EMBED. Notice that frame synchronization is re-established after a 'short time'. Could you put an upper limit on this time? See Tutorial Question Q4.

TUTORIAL QUESTIONS

- Q1** in the present experiment a 'stolen' clock signal was used. Why would transmission of the PCM signal via a bandlimited channel necessitate phase adjustment of this stolen clock signal to the PCM DECODER ?
- Q2** sketch the waveforms at the output V_{out} from the decoder, for the 4-bit and the 7-bit linear encoding scheme (and a 'large amplitude' sinusoidal, synchronous message at the encoder). A 'sketch' might show these as being the same, but a more accurate drawing would show more clearly the difference. Explain.
- Q3** how would you arrive at a specification for the reconstruction filter used in this experiment ?
- Q4** from the information in Table A-1 make some quantitative comments on the length of time the built in circuitry of the PCM DECODER would take to recover the frame synchronization signal FS from the incoming data stream. Were you able to verify this by observation ?
- Q5** two sources of distortion of the reconstructed message have been identified; they were called sampling distortion and quantizing distortion.
- a) assuming a sample-and-hold type sampler, what can be done about minimizing sampling distortion ?
- b) what can be done about minimizing quantizing distortion ?
- Q6** quantizing distortion decreases with the number of quantizing levels available. There is usually a price to be paid for such an option. What would this be ? Was that apparent in the present experiment ? Explain.
- Q7** companding is claimed to offer certain advantages. What are they ? Were you able to demonstrate any of these during the experiment. Explain.

APPENDIX

automatic frame synchronization

The PCM DECODER module has built in circuitry for locating the position of each frame in the serial data stream. The circuitry looks for the embedded and alternating '0' and '1' in the LSB position of each frame.

The search is made by examining a section of data whose length is a multiple of eight bits.

The length of this section can be changed by the on-board switch SW3. Under noisy conditions it is advantageous to use longer lengths.

The switch settings are listed in Table A-1 below.

left toggle	right toggle	groups of eight bits
UP	UP	4
UP	DOWN	8
DOWN	UP	16
DOWN	DOWN	32

Table A-1: synchronization search length options

