

Anywhere Travel Companion

Operations Manual



Introduction	1
Map Screen	2
TOOLBARS:	3
UNIVERSAL FINDER	4
DIRECT TO	4
FIND NEAREST ANYTHING™	4
FLIGHT PLAN	4
FLIGHT CALCULATOR.....	7
EMERGENCY MODE.....	7
PERSONAL DIGITAL COPILOT	8
VIEWS	8
XM WEATHER SETTINGS	12
ZOOM Options	12
TOOLS	13
SETTINGS MENU:	17
AIRCRAFT SETTINGS:	17
Using XM Weather:.....	19
XM Activation and Refresh.....	19
METARS and TAFS	20
Updating ATC	20

Introduction

The Anywhere Travel Companion (ATC) is a unique and high performance touch screen handheld device developed specifically for mobile navigation both in the aircraft as well as in an automobile. The automotive application instructions, basic operations and care of the unit are covered in a very detailed and easy to read manual on the HP 310 Companion CD in the original shipping carton. Familiarizing yourself with this device using those instructions first may help you gain an excellent understanding of how this powerful device works.

This manual contains complete operation instructions for the Anywhere Map and XM WX application built into this device.

Starting Up

To activate/deactivate the ATC, press and hold the power button. The initial screen you're presented with after a cold power up is the Main System Menu:

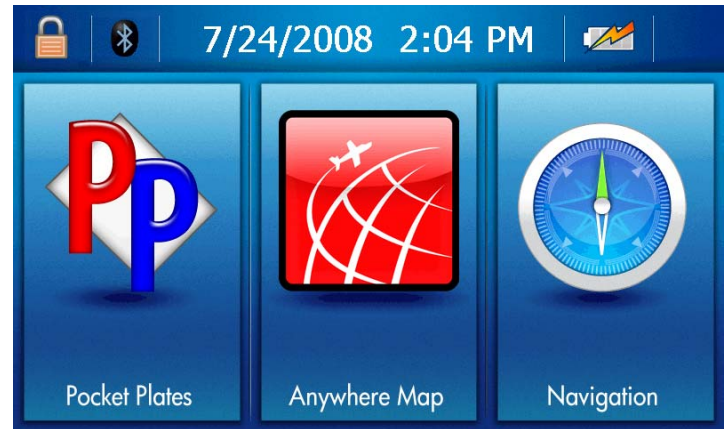

NOTE: Use the Power button to turn the power on or off. If the device is switched off while navigating on the ground or in the air, the GPS stops working. Consequently your position is not calculated, the track log is not saved, and the navigation stops. When you turn the device on, your ATC continues navigating as soon as the built-in GPS determines the location.

Tapping the Navigation button will take you to the Oasis control panel:



Oasis is the standard interface of the machine, which offers access to 3-D street mapping, contact and phone number management, and entertainment.

To begin using Anywhere Map, simply tap on the Anywhere Map button and after a brief loading sequence you'll be presented with the a map screen similar to this one:

Map Screen

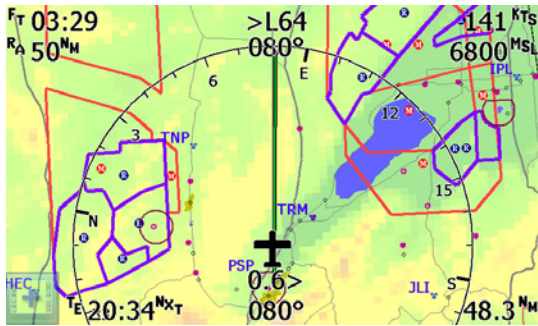

NOTE: NEVER REMOVE THE ATC MEMORY CARD while Anywhere Map is running as database corruption may occur.

OVERVIEW:

The main map screen is highly interactive and can be easily customized to show your choice of standard aeronautical chart items as well as numerous (unique to Anywhere Map- features including Cones of Safety, a Virtual Glideslope indicator, and Obstacles as low as 200' AGL. Many of the items you see on the main map screen are able to be tapped for more information. A single tap on items such as airports, obstacles, navaids, graphical METAR flags, and MOAs/Restricted areas will bring up a small text box containing 'quick' information about the selected item. These text boxes will auto-hide after a few moments, OR can be cleared immediately by tapping the "Clear All Tags" button that appears just below the airplane icon while any text boxes are activated. Double tapping (tapping the same item twice in rapid succession) will bring up the complete details for the selected items. Airport data screens deliver items such as radio frequencies, remarks, raw textual METAR/TAF information, runway data, and Taxi Express™ GPS enabled taxiway diagrams. Adding the selected airport or navaid item to the flight plan can also be done on these screens. For map screen customization instructions please reference the VIEWS section of this manual.

The map screen also contains features that are always displayed and are always located in the same fixed position for easy reference regardless of user configuration.

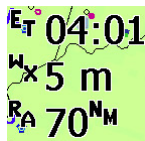

Starting in the top left, you'll find the Flight Timer area. This area can be used to display 3 different timers. FT or Flight Timer can begin at your designated taxi/runway speed and keeps track of the time aloft. ET or Elapsed Timer is a 'stopwatch' type function, which can be handy on approach. ZT or Zulu Time can also be displayed making second-guessing your time conversion from local to Zulu time a thing of the past. To use this area, simply tap on it to change modes until the desired timer is selected. The ET can be cleared by tapping on the elapsed time and then tapping the blue "Clear ET" tag that comes up. Zulu time is calculated automatically using the internal NMEA GPS clock.

Directly below the Flight Timer area is the weather status area. The WX status displays quite a bit of data about the XM WX portion of Anywhere WX with a single line of text. This single line will toggle between the current state of the WX Radio receiver/age of the NEXRAD file displayed and the quality of the signal being received

from XM Satellites. Listed below are the items that can be displayed and what they mean:

STARTUP- Anywhere Map is connecting to the Bluetooth Radio in the ATC for the com port and connection of the WX Radio (WX Worx Dual Ensemble receiver).

INIT= Initialize. Anywhere Map is searching in an attempt to connect to a WX Radio.

ACT CHK= Activation Check. Anywhere Map is checking the activation status of the WX Radio.

REQST= Request. Anywhere Map is requesting the appropriate items for the WX Radio unit to decode for display on the map screen.

WX: --- = the first NEXRAD radar file has not been received yet. Normally the first radar file takes 4-6 minutes to appear on the screen

WX:0m = The current radar file being displayed on the screen has just been delivered via the XM WX broadcast and is currently 0 minutes old. 3 minutes after this image is delivered the time will then show "WX: 3m"

ACTXM = The WX Radio receiver has confirmed to Anywhere Map that it is not activated or that it hasn't been used recently and doesn't know how to decipher the current encryption of the weather files being delivered by XM satellites. See page 19 of this manual for more WX Radio Activation/Refresh instructions.

XM-ANT = XM Antenna is not connected or is reported to be defective by the WX Radio box. Try removing/re-inserting the WX Radio antenna. If this message persists, the antenna may need to be replaced.

Signal quality is reported by 3 green bars for GOOD signal, 2 yellow bars for FAIR signal, 1 red bar for POOR signal, and NOXMSAT which means the antenna is connected but doesn't have any reception normally due to a poor/non-existent view of the sky.

NOTE: After boot of the Anywhere Map software and connection to the WX Radio box has been established through Bluetooth, the signal quality to XM satellites will be displayed following INIT, ACT CHK, and REQST phases have completed (approx 30 seconds or less). Once an acceptable level of signal (GOOD or FAIR) has been maintained for 4-6 minutes, the first WX files will begin to show up automatically on the map screen. More on the XM Weather operations can be found in the XM Weather section of this manual.

The last line on the top left map screen area is the Range indicator. The example shown on the previous page illustrates a 37 statute mile range. This distance is measured from the aircraft position on the map screen to the top arc of the compass rose.

Moving on to the upper right corner of the screen you'll find the GPS status.



This area will display "NO SAT" if the internal GPS hasn't acquired at least 3 satellites sufficient to provide

a 3D position on the map screen. Once the GPS acquires your position this area will display your ground speed and GPS altitude in feet above mean sea level or MSL. GPS acquisition time usually takes 15-30 seconds with a clear view of the sky, but can take 2-3 minutes if the unit has been transported 60 or more miles while powered OFF. Upon GPS acquisition, the map screen will localize to show the aircraft location in the proper position on the map screen. The GPS status area has 2 areas that can be tapped for more information.

Tapping 'KTS' will quickly change the map from metric to English measurements resulting in ground speed being displayed in miles per hour or 'MPH' and map distances are converted from nautical miles (NM) to statute miles (SM). Tapping 'MPH' will change back to metric measurements.

Tapping the altitude readout will recall the strength of satellite lock currently held by the internal GPS. '3D 10SAT' for example can be interpreted as: 3 dimensional lock tracking 10 satellites. This readout reverts to the GPS altitude automatically within a few moments.

The top center of the screen just above the peak of the compass rose, a 3-digit number shows the current heading of the aircraft.

The lower left and right corners of the map screen are reserved for the active flight plan data. The lower left corner will display the estimated time enroute (ETE) or estimated time of arrival (ETA) once a flight plan is activated. The distance to the next waypoint or to the destination, appear in the lower right. If the map doesn't have an active flight plan, the lower left and right corners of the map will be void of these fields. These features will be further described in the Flight Plan section of this manual.

Note:  this button will always return you directly to the main Map screen.

About  displays the version of Anywhere Map software you're using along with the effective dates of the 28 day GPS mapping data installed.

 closes the Anywhere Map software completely when you're done flying.

TOOLBARS:

The ATC uses a highly sensitive touch screen as the primary input means. Anywhere Map features and tools have been categorized into toolbar buttons that can be recalled by tapping the transparent button in the lower left. Tapping on the toolbar icon will recall 2 banks of tool buttons shown below:

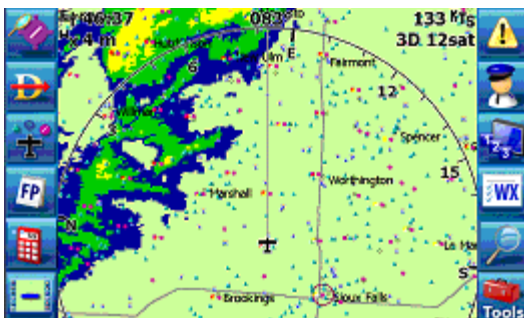

Left Side top to bottom:



Universal Finder: Search utility for airports, nav aids, fixes/intersections, & user waypoints.



Direct To: Sets up "GPS Direct" from current loc. to any airport, nav aid, fix, or user waypoint.



Find Nearest: Quick list closest airports, nav aids, fixes, ATC center, AWOS, cheapest fuel, etc.



Flight Plan Manifest: Full details of flight legs, save/load flight plan, Route Wizard, etc.



Flight Calculator: Calculate density altitude, true air speed, and winds aloft.



Toolbar show/hide toggle: Show/hide left and right toolbars on edges of map screen.

Right Side top to bottom:



Emergency: Single tap to enter E-mode and pick airport and activate emergency descent VNAV.



Personal Digital Copilot: Setup reminders for switch tanks, lower gear, & begin descent.



Views: Quickly select and modify your preset map display configurations.



WX Settings: Show/hide XM WX items from the map display.



Zoom/Backlight settings: Preset zoom levels, backlight adjustment, & night/day toggle.



Tools: Leaves map screen for setup of aircraft profiles and advanced functions.

UNIVERSAL FINDER

The Universal Finder is a powerful way to find items in the Anywhere Map database to which you may navigate including airports, navaids, fixes, and user waypoints.

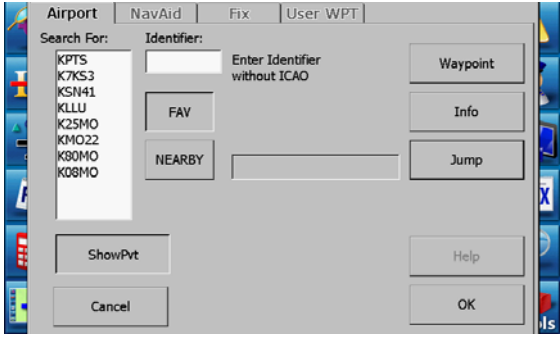

The Universal Finder screen is constructed with the following sections:

Type Tabs across top: these tabs allow you to select which type of item to find – airport, navaid, fix, and user waypoint

FAV / NEAR: These buttons allow you to list the results in the selection box either by the most frequently used or by nearest to your current GPS position.

Range/Bearing: This box, to the right of the history/suggestion area, shows the distance and bearing from your current position to the item you have highlighted in the list box.

Entry box: Enter your search criteria in this box to see the list respond with items that fit your criteria. Use the on-screen keyboard for text entry if you do not see the item you're after in the Selection box below the Entry Box.

Hide KB: hides the pop up keyboard so you can see the rest of the UF function buttons.

Jump: Directs Anywhere Map to jump to the item you have selected. If you have a GPS connected, the map will change to "Preview Mode" when you jump because the map is no longer showing your current GPS position. To cancel and return to your current position on the map, simply tap "Restore Position" in the upper right corner of the map.

Waypoint: Inserts the item you have selected as a waypoint in the active flight plan. You will see a window appear that gives you the option to decide how the item should be inserted into the plan: as a new destination (new plan), as next waypoint (literally, the one you'll fly to next directly from your current position), as a waypoint (inserts the waypoint into the flight plan sequence using the course as a guide for insertion), and as final destination (extends the current flight plan to this new waypoint as it is now the real destination, and occurs after the original destination).

Info: Opens the Airport Information screen which provides runway data, radio frequencies, GPS enabled Taxi Express airport diagrams, remarks, Virtual Approach procedures, 100LL fuel prices, FBO facility directory, and weather information.

Note: See item #2 on page 11 for practical usage and text entry into the Universal Finder.

DIRECT TO

Opens the Direct To screen so you can alter your flight plan OR create a Direct (single leg) route to a particular point. The screen opens in the basic form shown below with airports listed first, in order of nearest to farthest. Farther down the list changes to navaids, again with the nearest being listed first. Finally the fixes are listed. You can also open the Universal Finder from here to select a more distant waypoint if you don't find it in the list on this screen.

One distinction of the ATC Direct To screen above nearly all other systems on the market: It shows the list of waypoints when you have an active flight plan. In this case you can use the Direct To to skip waypoints and fly direct to a waypoint much farther down the plan from your current position. This happens often when ATC clears you to bypass several short legs when departing a terminal area, for example. Instead of searching for a waypoint you know is in the plan, simply tap Direct To, and pick from the list of active flight plan waypoints.

FIND NEAREST ANYTHING™

This function allows you to access ATIS, AWOS, FSS, ATC CENTER, VOR's, and Airports within approximately 50-100 nm of your current position. This is especially handy for looking up nearby facilities that may control SUAs or to get enroute weather information.

Placing a checkmark in the Only Look Ahead box will return only results along your route lying ahead of your current GPS position. With a subscription to 100LL fuel data, you'll also be able to search for the nearest Cheap Fuel.



Pressing the Include NDB box will return both VOR's and NDB's when the search is requested.

FLIGHT PLAN

A flight plan is a list of waypoints that define the route of a flight. Each flight plan will have at least a START POINT and a DESTINATION. Many flights will also include intermediate WAYPOINTS, which are points along a route that define the path, generally to keep the flight path out of undesired areas such as restricted airspace.



Tapping the  button will open the Flight Plan Manifest screen where you can view the leg details of your active flight plan, save/load a flight plan, and even add wind data and/or VNAV attributes to each leg. You can also re-arrange the waypoints, clear the flight plan from the map, or access the Route Wizard tool.

The flight plan screen contains a listing or manifest of the flight legs and waypoints as well as three management tabs (Edit, Create, and File). In the manifest window you can see the data that has been calculated for each of leg of the flight including waypoint name, course, speed, winds, VNAV, time, distance, fuel used. The flight totals are summed at the bottom of the manifest area.

EDIT Tab: Contains the buttons that allow enroute flight plan modification. Frequently a controller may order changes to your flight plan that require addition or deletion of waypoints, re-ordering waypoints, or even entering holds. The functions on this first tab were chosen because they are the most common activities.

Add WP: Opens the Universal Finder screen so you can lookup an airport, Navaid, fix or user waypoint for inclusion as a waypoint in the current flight plan. This is repeated from the Edit tab.

Delete WP: After selecting an existing waypoint (single tap) in the flight plan manifest, this allows you to delete the waypoint. The result will be that the flight course will then run from the prior waypoint directly to the next waypoint. This is repeated from the Edit tab.

VNAV: After selecting a waypoint, allows you to specify an altitude at which you want to cross the waypoint. Once set, a blue arrow will display next to the waypoint designator (upper center of map screen) showing you whether to climb or descend as you approach the next waypoint. In addition, a required rate of climb/descent number will display in the lower right corner and a target arc will arch across the flight course showing the point at which you'll reach the specified VNAV altitude based on your current rate of climb/descent and your ground speed. This is repeated from the Edit tab. For more information, see VNAV Concepts page .

Next WP: Allows you to select a waypoint from the manifest and make it the next waypoint in the plan. This will NOT delete any intermediate waypoints that may exist, but does set the waypoint number, bearing and distance data on the map to the waypoint selected. Anywhere Map will normally "follow" your flight progress and will automatically know which flight plan waypoint is "next" but in those cases where it gets out of sync with the pilot, this button allows you to synchronize the software.

Winds: Opens a screen to enter wind speed and direction. There are two cases of using winds in the flight plan: 1) manual entry of the winds (available for both Anywhere Map and Anywhere Wx customers) and 2) forecast winds from the winds aloft feed in XM weather (Anywhere WX customers only). If XM is available, then the winds for the altitude selected in View Setup > Wx will be used to calculate speeds, times, and fuel. If XM is not available, then winds can be entered manually using this WINDS button or you can leave them at zero for a no-wind plan.

Hold: Toggles with UnHold. This function will PREVENT the map from advancing to the next waypoint automatically when a flight plan waypoint is passed. If ATC were to instruct you to "hold east of OSWEGO" and you were approaching this VOR from the east, tapping this button before arrival would prevent the waypoint sequencing logic in Anywhere Map from noting station passage, even though you would be over-flying the VOR on each holding pattern orbit. To resume navigating, tap the UNHOLD button when inbound to the VOR, and the next waypoint will advance automatically when crossing the VOR.

Move Up / Dn: These buttons will take the selected waypoint/leg of the flight plan and move it up or down in the order of the flight plan allowing a re-sequencing of the waypoints in the manifest.

Close: Closes the flight plan screen and returns to the map with any changes made in this screen implemented on the map.

CREATE Tab:

These flight planning functions are primarily used in the creation of new flight plans and the modification of existing ones. The most common functions are repeated from the Edit tab.

- **Add WP:** Opens the Universal Finder screen so you can lookup an airport, Navaid, fix or user waypoint for inclusion as a waypoint in the current flight plan.
- **Delete WP:** After selecting an existing waypoint (single tap) in the flight plan manifest, this allows you to delete the waypoint. The result will be that the flight course will then run from the prior waypoint directly to the following.
- **VNAV:** After selecting a waypoint, allows you to specify an altitude at which you want to cross the waypoint. Once set, a blue arrow will display next to the waypoint designator (upper center of map screen) showing you whether to climb or descend as you approach the next waypoint. In addition and required rate of climb/descent will display in the lower right corner and a target arc will arch across the flight course showing the point at which you'll reach the specified VNAV altitude based on your current rate of climb/descent.
- **Next WP:** Allows you to select a waypoint from the manifest and make it the next waypoint in the plan. This will NOT delete any intermediate waypoints that may exist, but does set the waypoint number, bearing and distance data on the map to the waypoint selected.
- **Route Wizard:** Tapping the Rt Wizard Button will bring up the Route Wizard screen. Enter the full ICAO Airport identifier in the From and To fields. Each Via (optional waypoint) identifier should be separated by a space. See the Route Wizard explained in further detail with an example on page 13.
- **Reverse:** This function will reverse the order of the flight plan in use for the return trip.

FILE Tab:

LOAD button: Calls up a screen containing previously created and saved flight plans. If the flight plan you wish to load shows on the screen, tap the filename and tap OK.

Save: After creating a flight plan on the ATC, enter this screen and type a unique filename in the “save as” box of this screen. For instance to save a flight plan from PTS to MCK you might type “PTS 2 MKC” in the SAVE AS box and tap the Save button.

Clear: This will remove the current flight plan from the screen. This will not delete the flight plan from the memory.

Delete: This will permanently remove the flight plan from the PDA’s memory.

Note: The Anywhere Map computes fuel consumption, course, and ETA. Entering Aircraft Profile information will make these calculations more accurate. Place wind direction in the top text box, and place the wind speed in the lower text box. These values may be easily edited with the stylus on the slider controls. These values can be shown as the wind vector in the upper left corner of the screen unless changed or overridden. Tap OK when done.

Creating Flight Plans

There are several ways to create a flight plan on the ATC. One important thing to remember when creating flight plans is that the Start Point is the aircraft’s location on the map screen. If the internal GPS has acquired its position, this is where your flight plan will begin. If you’re indoors and the GPS hasn’t acquired its position you can manually ‘jump’ your aircraft to the desired Start Point before beginning your flight plan creation. The only exception to this rule is the Route Wizard method. Here are the different methods you can use to create flight plans in the ATC.

1. **Map based flight plan creation:** If the waypoint icon you wish to use is visible on the map screen, simply pick the destination from the screen by double tapping on it and tap the Waypoint button on the information screen that appears. If you did not have any active flight plan, the map screen will return and you will have a ‘GPS Direct’ flight plan from the Start Point to the selected item. If there already one or more legs created, you’ll be presented with a multiple choice screen to make sure the item is integrated properly into your flight plan:
 - **Go Direct To-** This option will erase any current flight plan and go ‘GPS Direct’ to the selected item.
 - **As Next Waypoint-** This option will add the selected item before all other waypoints chronologically, making it your next plotted waypoint.
 - **As A Waypoint-** This option will automatically add the selected item chronologically into your existing flight plan.
 - **As Final Waypoint/Destination-** This option will add the selected item on as the last waypoint in the existing flight plan. When creating a multi-leg flight plan in

chronological order, each waypoint added would be done so using this option.

Database search based flight plan creation: Tap the UNIVERSAL FINDER  icon on the toolbar and enter the identifier. Then tap the Waypoint button on the information screen that appears. The Universal Finder screen is very handy to use, even if you you’re unsure of the exact ident. The universal finder allows you to save many keystrokes entering an airport or fix identifier as it always lists the eight nearest matches to the partial identifier entered. This ‘auto-complete’ function can nearly eliminate the need to enter the entire identifier. See the Universal Finder section of this manual for more instructions of this feature.

DIRECT TO based flight plan creation: Tap the DIRECT TO  button and select a waypoint from the list of nearby airports, nav aids, fixes, or waypoints from your active flight plan.

Rubber Band Flight Plan creation: The Rubber Band Flight Planning tool is fast, easy, and convenient. This tool allows you to ‘drag and drop’ your course line to different airports or nav items (or any infinite point on the map) thereby creating the flight plan course. This is a handy feature for making minor in-flight adjustments due to ATC vectors, weather and terrain deviation, or just for sight-seeing. Activate this feature by tapping:  Tools+

 and you’ll see on the map a red circle on your actual waypoints, and a blue circle over the midpoints of each leg. The blue circles allow you to create a new waypoint by dragging it to the desired position thus making it an actual waypoint in your flight plan (which turns it red). The red circles (waypoints) can also be ‘dragged and dropped’ to change waypoints/destination on the fly.

Route Wizard based flight plan creation: The Route Wizard is a quick and easy way to create a flight plan if you know the starting point and destination of your flight, and the names of the waypoints or VOR’s you are going to use. The idents you enter must be typed correctly, or they will be left out of the flight plan by default. Tap the  + Create tab + Route Wizard button and enter in the airport of origin’s identifier in the From box. Next, enter the airport identifier for the destination airport in the To box. Airports must be entered using four letters/numbers. Prefix three letter identifiers with a “K” if in the lower 48 United States, “C” for Canada, and “P” for Alaska, for example.

Finally, use the ‘VIA’ box to enter the VORs and fixes you wish to travel by way of , if any. Separate each entry with a space. VOR/NDB’s must be entered as three letters and fixes must be entered as 5 letters. Tap the OK button, and you will be returned to the Flight Plan Manifest screen.

Look over the flight plan you’ve just created. If any of the legs are in the wrong spot, you can highlight the leg by single tapping on it then tap the Move Up or Move Down button until it is in the right position.

Here is an example of a flight from Johnson County Exec to Atkinson Muni. Via CNU vortac:

FROM: kojc TO: kpts VIA: cnu



VNAV CONCEPTS:

The basic concept of VNAV is the TARGET ALTITUDE. Anywhere Map allows a target altitude to be assigned to any waypoint in a flight plan. If a target altitude is active for a waypoint, the software will compute the rate or climb or descent necessary to reach that altitude, based on the time-to-fix and altitude difference. When the next waypoint has a target altitude associated with it, the software will draw an up or down arrow next to the fix name at the top of the screen, indicating that a climb or descent is required.

Tap  + Views Settings + Format tab + VNAV Info button to enable this powerful tool and the target rate of climb or descent will be shown in the lower right corner of the map screen. The value shown is not the current rate of climb/descent, but the rate of climb/descent NEEDED to reach the target altitude concurrently with reaching the fix.

If the rate of climb or descent is greater than 200 feet per minute, a VNAV target altitude arc will appear in front of the aircraft at the point in space where the target altitude will be reached. This arc will span from about 20 degrees left to 20 degrees right of the aircraft.

Note: GPS altitude 'jitter' may cause this arc to jitter a bit as well, but if the aircraft is in a steady climb or descent, this arc will show clearly where the target altitude will be reached.

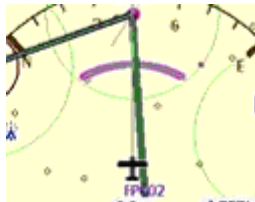

To set up a VNAV target altitude, enter the flight plan using any method (see Flight Plan portion of the manual) and then enter the Flight Plan Manifest screen . Next, tap once on the desired waypoint in the flight plan listing in this screen – this will highlight this leg of the flight plan. Then tap the VNAV button at the bottom of the screen to call up the TARGET ALTITUDE slider. Use the slider control and/or the scrollwheel on the side of the ATC to enter and 'fine tune' the target altitude. You may also tap in the altitude box and type in the altitude with the keyboard number pad if you wish. Tap OK to set the target altitude, or DISABLE VNAV to shut off VNAV coaching.

Automatic VNAV

When you set up a flight plan to an airport, VNAV is automatically selected with a target altitude of the airport's elevation plus 1000 feet. This will result in arriving at the airport at approximately pattern altitude.

IMPORTANT: Remember that VNAV is always based on GPS ALTITUDE, it does not allow for any difference between GPS altitude and indicated altitude (which is what ATC expects everyone to be using).

IMPORTANT : VNAV only works on the NEXT waypoint in the flight plan. Thus if you have a target altitude to a distant waypoint, and an intermediate waypoint is inserted between the distant waypoint and the current position, VNAV coaching will not begin till the intermediate waypoint is passed.

FLIGHT CALCULATOR

Density Altitude: To figure the Density Altitude, type in the Outside Air Temperature (OAT). Use the slide bar underneath the text box to get close and then fine-tune it with the arrows on either side of the text box. When a temperature is entered, the deviation from ISA is computed and saved. If you re-enter this screen later in the flight, the temperature value will be remembered and filled in for you. Tap the Density Altitude button, and it will be displayed in the gray box above the button.

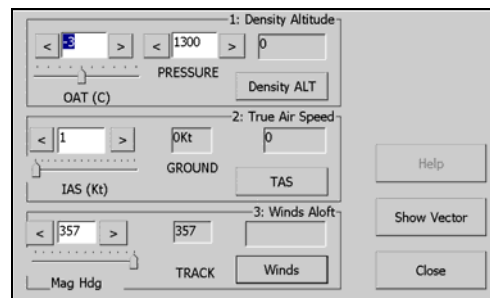

True Airspeed: Enter the Indicated Air Speed (IAS) in the text box in knots. Use the slide bar underneath the text box for a general number, and fine-tune it with the arrows on either side of the text box. The True Air Speed (TAS) will show in the gray text box above the TAS button.

Winds Aloft: Enter the Magnetic heading of the aircraft in the box shown. The GPS reported ground track is shown in the TRK box. Tapping WINDS will cause the actual winds aloft to be calculated and displayed. This step assumes that the altitude, temperature, and airspeed have already been computed. To have a visual reminder of the wind data just entered, tap Show Vector. To hide the wind vector, go to the Flight Plan screen and tap WINDS and tap HIDE VECTOR.

EMERGENCY MODE

Replaces existing flight plan with Direct-To plan to selected airport with VNAV to the airport such that it shows required rate of descent to get there.

Tapping this button on the toolbar also switches the display to VIEW 6, which should be preset to your preferences for an emergency landing.

Once an airport is selected by a single tap of the icon on the screen, this mode shows a "VNAV target arc" based on your current rate of descent and ground speed, which is actually the point at which you'll reach the ground (based on field elevation).

Since the VNAV target arc is based on actual GPS rate of descent and GPS groundspeed, the target arc is already compensated for headwinds or tailwinds. Due to GPS altitude jitter, the target arc will jump around somewhat however in an actual emergency if it consistently falls short of the target airport runway then you will likely NOT reach the field at the current glide speed and configuration. To cancel E-mode, tap File > Flight Plan or tap the Hot Key programmed for Flight Plan, then tap the File tab, then tap Clear. See VNAV Concepts on page 13 for more information.

PERSONAL DIGITAL COPILOT

These settings provide numerous safety capabilities for the user. These settings remind you to perform critical steps such as lowering the landing gear and turning on oxygen. When activated, a red or blue reminder will appear on the screen that will either hide on its own after several seconds or you can hide them by tapping them once.

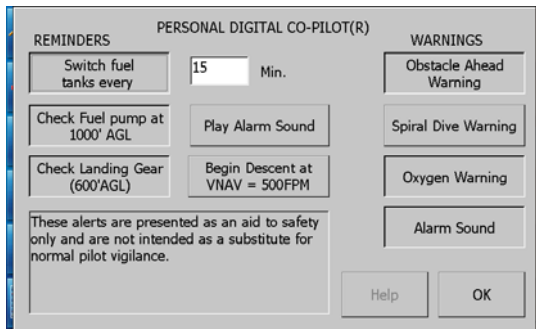

Optionally, you can also choose to have the ATC's audio speaker sound an alert when the reminders pop up. Check the associated box to turn on the alarm function.

Check Fuel Pump: This reminds you to check the fuel pump as you pass through 1000' AGL.

Switch Fuel Tanks: This reminds you to switch the fuel tanks. You set the time interval between switch tank reminders in the text box.

Check Landing Gear: This important reminder prompts you to check the landing gear when the airplane passes through 600' AGL.

Begin Descent: This pops up a reminder box when the required rate of descent to reach pattern altitude by the time you reach your destination is 500 feet per minute.

Obstacle Ahead Warning: Alerts you to the presence of an obstacle that is within 500' of your GPS altitude and within 10 nautical miles of your current position.

Spiral Dive Warning: Alerts you to a continuous change in track with a continuous descent.

Oxygen Warning: Reminds you to begin oxygen use when the GPS altitude is 12,000 MSL or above. (Remember, this is GPS altitude and not barometric altitude.)

VIEWS



Allows you to create, save, and change map display 'pre-sets'. Rather than making frequent and repetitive map display settings, you can save customized map views for specific flight needs and save them

under a name for rapid recall. For example, you could save a map view for VFR Day Operations with terrain and special use airspace turned off, but weather data, airways and fixes turned on.



By saving this configuration as VFR any time you select 1VFR the preset display settings take place. You may save up to 6 different View configuration pre-sets. View 6 is reserved for Emergency Mode and the settings automatically take place when you enter Emergency Mode.

To create and save a map view:

1. Tap  + 
2. Using the NAVAID, Airport, Airspace, Topo (Surface Features), Format, and Weather tabs, set the display features the way you want them to appear.

Select which View # to assign to this configuration (View 1-5).

NOTE: You should set up View 6 with the feature selections you wish to see in the Emergency Mode.

If you wish to give the map view a special name (such as IFR or VFR Day) then type this name into the View Name box on the SET Tab.

Tap Save View and your current feature settings will be saved under that view.

What is saved in a view?

All of the information in the View Setup screen with the exception of the FULL HSI setting.

Any weather display selections (show / hide NEXRAD, Metars, etc and Wind vector)

The zoom range

What is NOT saved in a view?

Aircraft profile information

Software settings NOT related to the graphical display of the screen

The status of the Full HSI as well as the virtual ILS and flight plan information

Sample views (come preset)

VFR View – This is a “sectional” looking display with shaded terrain, roads, lakes, airports, towers, and SUA's enabled

TAWS view – This is the VFR view with color coded terrain above and elevation values added

IFR View – This is an “enroute chart” looking view. SUA’s and class b/c/d/ airspace is suppressed, as is terrain. Holds and airways MEA’s are added in.

Approach View – IFR view with approach waypoints added in

Weather View – the IFR view with weather enabled (weather systems only)

Emergency view – a simple sparse view with Cones of Safety, DME to airport, compass rose display, no SUA’s or airspace information, but terrain turned on.

Special considerations about the Emergency view –

The E-View should be set up for fast screen update rates (turn off SFR’s, class b/c/d airspace and MOA’s, turn on Cones of safety and terrain if in a mountainous area (leave terrain off if NOT in a mountainous area). If private airports are enabled in E-VIEW, when you tap on the screen to select an emergency landing field, private airports can be selected, of they are not shown, only public airports can be selected.

NAVAID Tab: This tab shows all of the Navaid features that can be displayed.

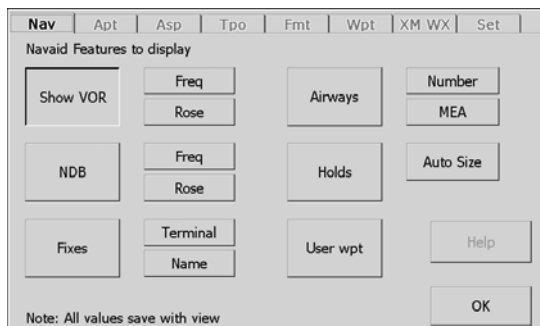

VORs and NDBs: You may display the VOR’s and NBD’s with or without the Compass Roses and frequencies.

Fixes: You may display the enroute fixes, the terminal fixes, and the names for the fixes.

Airways: The airways may be displayed with and without the number and the MEA shown.

Holds: Holds allows the holding patterns to be shown. Auto Size adjusts the size of the hold based on your ground speed so you retain one-minute legs.

User Waypoints: User waypoints to be shown.

AIRPORT (APT) Tab: Airport tab shows all of the airport information that can be displayed on the map such as elevation, frequencies, runway length, Taxi Express diagrams, textual weather, remarks, FBO services, and virtual approaches.

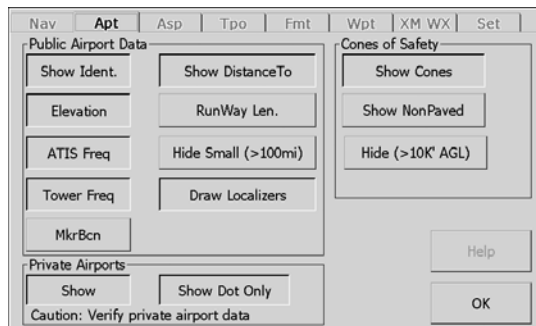

Elevation: displays airport elevation above sea level

ICAO: displays airport identifier

ATIS and Tower: displays CT and AT frequencies beside the airport at close zoom levels (approx 25NM)

Marker Beacon / LOC / ILS: displays marker beacons (as circles) and LOC feathers for associated airports

Distance To: displays distance from your current position to the airport

Runway Length: displays the length of the longest runway (in hundreds) next to the airport on the map, L55 means this airport has at least one 5500 foot runway. This data is only shown when zoomed in closer than 25 NM

Hide Small: Hides non-towered airports when zoom level (radius) is > 100 nm.

Cones of Safety®: To enable the Cones of Safety feature, place a check in that box. If you want to display Cones of Safety for non-paved runways, check that box also. To reduce screen clutter, you can also select to automatically hide the Cones at GPS altitudes greater than 10,000 feet MSL.

The last section allows the user to show private airports as a dot, or as a dot with a name, or not at all (no check marks).

AIRSPACE (ASP) Tab: Displays Airspace information as selected. In the box on the top, you control if you want the Class B/C/D Airspace shown, and whether floor and ceiling values of these airspaces should be displayed.

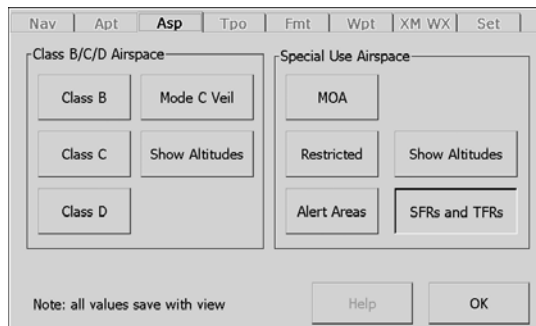

In the lower box, the Special Use Airspace is listed. These include MOA, Restricted, Alert Areas, TFR’s (Temporary Flight Restrictions) and Mode C veils. Checking “Show Altitudes” box will show the SUA’s altitude of operation. There is a grayed out box labeled “Warn Me”, this is a future feature, not currently enabled in the software. You can also see more information about the SUA if

you double-tap the center point of the airspace (at wider view levels there is a small dot there). This will show you the airspace, altitude limits, last regular hours of operation, and even the controlling facility frequency.

TOPO (Surface Features) Tab: Display options regarding geographic features and terrain. In the Surface Features box, you may display the lakes, highways, cities, state lines, and towers. You may optionally display the name of the cities, lakes and highways. Placing a check in the box next to Urban Areas will allow the user to see the outer boundaries of urban areas in a slightly darker color than the surrounding terrain. You can also choose to display loitering-sensitive objects such as stadiums and nuclear power plants, and may optionally display the 3 nm veil that surrounds them.

Data Tags are approach/departure frequency tags that appear around some of the higher density airspace. When zoomed out, there is a small green dot on which you can tap to see the frequency. When zoomed in, the dot is replaced with a rectangular box in which the frequency is displayed.

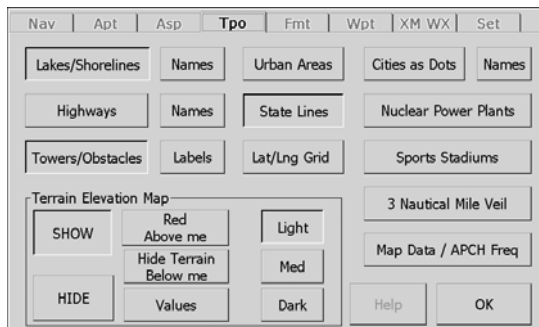

In the Terrain Elevations Map section, you can choose whether to display terrain. Terrain is depicted in colored tiles that denote elevation of a point within that tile. The size of each tile is 1 mile square (high resolution at close zoom levels). Terrain resolution increases as the zoom level is changed from wide to close. This is done to keep the map performance optimized. Terrain color is also adjustable. You can choose from light, medium, or dark. In the dark setting the lower terrain altitude will be rich dark green.

In the light setting the low altitude terrain will be very light green. Terrain color shading transitions from green to orange to brown at higher altitudes to finally white, making the mountain tops appear white. You may wish to use a lighter terrain color during the daylight hours if you are flying in an area with low elevations to improve contrast. In higher elevations it is often better to use a darker color.

The Terrain Settings group select additional options:

Red Above: In this mode the terrain that is above and near your GPS altitude is shown in 3 special colors:

Terrain 1000' to 500' below the aircraft is shown in **YELLOW**

Terrain 500' to 200' below the aircraft is shown in **ORANGE**

Terrain less than 200' below and all terrain above the aircraft is shown in **RED**

Terrain that is more than 1000 feet below the aircraft is rendered in normal colors.

Values: Turns on the display of the highest terrain value in each terrain tile. This is the highest elevation within that tile (in hundreds of feet) This is very handy for estimating the height of terrain ahead.

Above Alt: This turns on terrain mapping only when the terrain is above your current GPS altitude. This can be useful for reducing screen clutter in mountainous areas while still seeing terrain of particular concern (above you). This mode can be used in conjunction with RED ABOVE to include the “nearby” terrain (1000' to 200' below the aircraft).

Lat/Long Grid: Enables the drawing of Latitude and Longitude grid lines on the map.

FORMAT (FMT) Tab: FMT tab allows you to set various ancillary display features that either enhance the map, the data displayed, or the navigation capability.

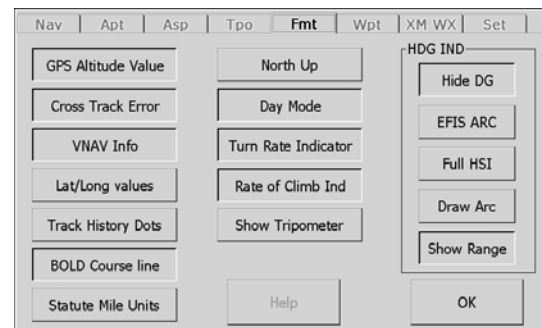

GPS Altitude: Displays GPS derived altitude in the upper right corner. Note that GPS altitude is actually very close to the correct geometric altitude, but it may vary significantly from the altitude indicated by a pressure altitude, depending upon the altitude AGL and the local deviation from ISA temperature. Temperatures +20C above ISA standard will cause the pressure altimeter of the aircraft to read approximately 200 feet low for each 5000 feet AGL. **Cross Track Error:** Your course deviation is shown on the map in the lower screen center in tenths of a mile. An arrow shows you in which direction your course is from your current position.

VNAV: This displays required rate of descent data in the lower right corner of the map when your descent to the destination airport pattern altitude (assuming 1000' PA) is 250 ft. per minute or greater. This box must also be checked to show VNAV information in flight plans. For more information see VNAV Concepts on page 12-13.

Lat/Long: Your current position in latitude/longitude is shown in the bottom left corner of the map.

Track History: This feature leaves breadcrumbs (small dots) along the path flown.

Bold Course Line: This function places a heavy black line on either side of the flight plan course line in normal flight. The course line is green for the active leg and aqua for all other legs of the flight plan.

Statute Miles: This toggles all map data between statute miles and nautical miles.

Day Mode: Toggles between the day color set (light background) and the night color set (black background).

Max/Min Mode: When you select the Maximum screen display mode (tap rough air button, then MAX) the button that cancels this mode will be in the lower right instead of the lower left corner of the screen.

Trip meter: Displays a Trip meter in the lower left corner that is the total distance flown since last reset. To reset the trip odometer, tap File > Tools > Odometer/Trip meter.

Hide DG: This removes the compass rose from the screen entirely.

EFIS Arc: This changes the compass rose view to an EFIS ARC display. This is also known as the “look-ahead” view because it also moves the aircraft position on the map to the lower third so you can see more area ahead of you than beside or to the rear. This setting can also be toggled from the map screen by tapping the tan button that has an aircraft and DG that arcs above it.

Full HSI: This will enable the HSI function to show on the screen and un-checking it will remove the HSI display leaving only the EFIS or compass rose.

Draw Arc: This will draw an arc on the EFIS ARC display on in the compass rose view. If unchecked, the Tick marks for 10 degree increments are drawn but the arc is not shown. The arc drawn when this is checked is the “zoom range” shown when radius (below) is checked.

Disp: R: NM: This is very handy for knowing what range is being displayed on the map. It displays the distance from the aircraft icon to the EFIS arc/circle. It immediately sets context for the distance between you and items being displayed on the map such as towers, airports, airspace, and especially weather. The range in nautical miles (or statute if so set) is shown in the upper left corner of the map under the flight timer. If this box is unchecked, the range value will display briefly when changing zoom ranges and will automatically hide after about five seconds to save screen real-estate.

North-Up Mode: Plane will appear in the center of the screen, and it will rotate instead of the map. Map screen will always have North at the top of the screen.

Turn Coord: Displays a circular Rate of Turn instrument in the lower left corner of the map. The rate of turn, in degrees per minute, is shown digitally.

Rate/Climb: Displays a Rate of Climb/Descent indicator in the lower right corner of the map.

Note: A map view can be activated at anytime by selecting the desired view button under: 

WAYPOINT (WPT) Tab: This tab allows you to control how waypoints are used in the creation of flight plans and also during the flight.

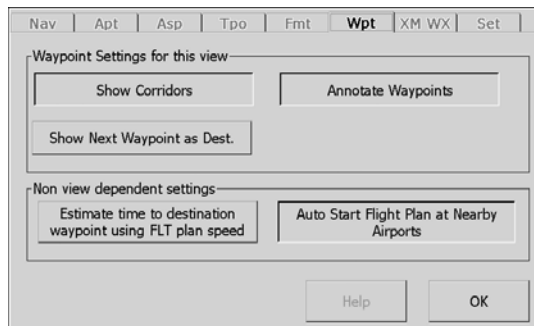

Show Corridors: In a flight plan, waypoints designate course changes as you progress. Changing course as each waypoint is reached is usually done after you cross the waypoint (Navaid, fix, etc.) which also usually results in your being off course for the next leg and having to return to the line as you start down the next leg. Many pilots want to smooth the corner so they turn before reaching the waypoint, thereby making a nice transition from one leg to the next.

However, in doing so they actually do not fly directly over the waypoint and therefore Anywhere Map needs to know whether you just missed it (and you intend to return to it) or whether you intend for the next leg to become active. The corridors have been created to allow "corner cutting" so that you can smooth the corners in your flight and still have the flight plan logic follow as you progress.

The corridors are depicted as gray or red lines (red if the waypoint is set as a holding waypoint) that bisect the angle made by the legs that are inbound and outbound from the waypoint. The length of the line is based on the distance between waypoints and the angle made by the two legs. As long as you cross the corridor line, the waypoint will be considered "crossed" and the next leg will become active.

Show Next Waypoint as Destination: Displays the next waypoint in a flight plan at top center of the screen. The waypoint can be an airport, fix or user waypoint. If unchecked the final waypoint of the flight plan is shown at the top of the screen.

Annotate Waypoints: The waypoints you are using in the flight plan have data tags on them even if the names of the waypoint type (VOR, NDB, Fixes, etc.) are turned off in the settings.

Estimate time to destination waypoint using FLT plan Spd:

If this box is UNCHECKED, the estimated time to destination is computed using the total flight plan distance divided by the current ground speed. This is the method used by most GPS units, and it is conceptually very simple. This is Current Ground Speed mode. This method does not work well on “round robin” flight plans, with strong winds aloft.

With the box CHECKED, the time to destination is figured using the TE to the next waypoint (using current GPS groundspeed) PLUS the sum of the TE's for each subsequent leg shown in the flight planning screen, using the speed shown in the flight plan screen. This method is generally more accurate, but requires that the aircraft speed and winds aloft be properly entered so the resulting speed is accurate.

Auto Start FP at Nearby Airport:

If this box is unchecked, when you select an airport and tap FLY TO, you will be asked “Start at airport?” if you are within about 3 miles of an airport.

If you tap NO here, the flight plan will originate at a special user waypoint using current GPS position on the map. If you tap YES here, the flight plan starting point will be at the “reference point” of the nearby airport.

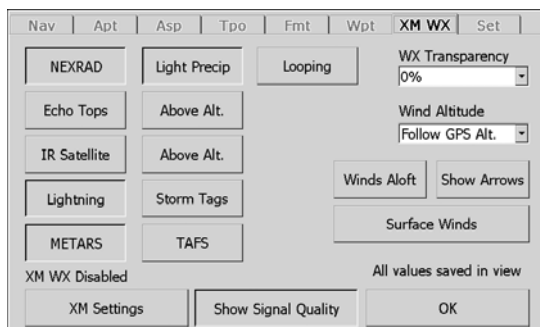

If checked it will be assumed that your answer is always YES to this question.

WEATHER (WX) Tab: WX tab allows the weather products to be selected for display or hidden from view. It does not control reception of the weather data, only the display. In addition, by setting weather display features and then saving the view, the view you are modifying will always have those weather display settings associated with it until further modified and saved. This way, you can have just METARs turned on in one view, and the full compliment of weather features turned on in another view.

These settings are duplicated in the  menu for quick and easy access.

SET Tab: Set Tab allows you to save your recently configured settings under a default or custom name.

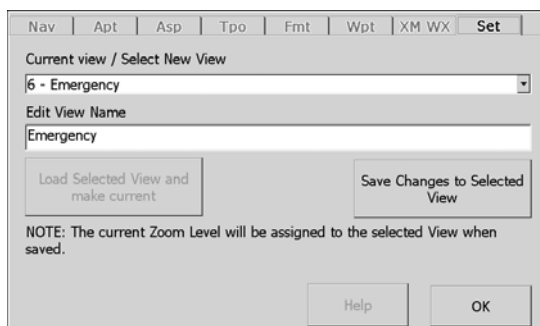

XM WEATHER SETTINGS

These check boxes turn on and off the display of the associated weather products. This does NOT control reception of the products and this varies according to the weather platform being used and the content being received from XM Satellite Weather, the weather data provider. This feature **REQUIRES** a WX Worx Dual Ensemble receiver purchased from Control Vision Corp. This component is optional equipment when you purchase an ATC. It also requires a subscription to XM Satellite Weather for the data broadcast to be decoded by your receiver.

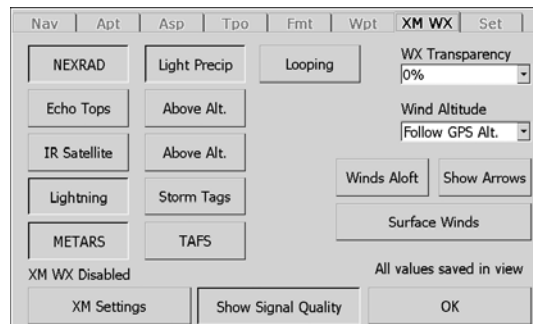

For XM Weather, the settings control display of the specific weather items on the Map. Remember, XM is a broadcast over which the pilot has no control. They send each file type (radar, METARs, etc.) on a schedule and once your system is powered on, you can only wait until the next files are broadcast. For example, radar is broadcast every 5 minutes and METARs/TAFs every 12 minutes. This screen also contains the ‘advanced’ button, where more XM controls are located including the tools required for re-activating your XM unit should it lose activation.

We suggest you do not use the advanced button without help from Control Vision technical support. Most importantly, the status shows that you are receiving weather files and also signal strength. The Sat Error rates need to be as close to 0 as possible. The higher they are, the greater the chance that weather files will not be received properly and therefore will not be displayed. In this case, the age of the weather file being displayed will simply continue to count upward until the next file broadcast.

Antenna placement is the single biggest reason that updated weather files are missed and not displayed. If you have low error rates, your chance of getting all the weather data is much better.

ZOOM Options

Changing the range on the ATC couldn't be easier. The scroll wheel on the top-right side of the chassis allows you to zoom in or out on the main map screen. This is an easy, tap-less way to make adjustments to the map range you're viewing.





Tapping the  button will recall the zoom screen and allow you to pick from several different pre-set zoom levels and/or activate the Auto Zoom, Zoom to the entire Flight Plan, Box Zoom or Pan Zoom tool.





This screen is also used to switch between the Day and Night modes, enable the map panning tool and adjust the backlight brightness of the ATC:

 Enables the map range to automatically decrease (zoom in) as you approach the next waypoint or your destination. Pressing the same button will deactivate this feature.

Tapping  will increase the range on the map screen just enough to show your entire flight plan course line all on one screen. Also handy for viewing any possible weather threats and MOA/Restricted or Class airspace you may be on course for. This feature also puts the map into Preview Mode (disables GPS temporarily). Tap 'Restore Map' to return to the main map mode. The Day/Night button will toggle the color scheme to make Anywhere Map more useable during very bright or very dark conditions. Adjusting the backlight brightness (5 different settings)

can be done with: 

 Great follow up feature to the  button. After enabling zoom to entire flight plan, you can quickly and easily zoom in on any area of interest by simply tapping down and dragging diagonally to draw a box on the screen. This dotted-finger/stylus from the screen. When you're finished, tap Restore Map in the top right corner and the map screen will return with the zoom level that you left it at (before zooming to entire flight plan) and the GPS tracking will resume.

 Tap to Pan mode enables you to move the map position ahead, backward, and sideways by single-tapping on the screen. Each time you tap, the map moves to that position. If you have a GPS connected, then the map will also go into Preview Mode, which reminds you that you are looking at an area that does not include your current position.

Hint: To cancel the Preview Mode, tap the red square in the upper right corner, Restore Map.

Hint: To cancel the Tap to Pan mode, tap the cancel icon in the lower right corner. This will restore the ability to interact with the map items.

TOOLS

Tapping the Tools menu button will switch from the main map screen to a page that looks like this:



 This feature acts as a poor man's autopilot, not because it controls the airplane, but because it helps you keep the airplane on a constant heading and/or altitude.

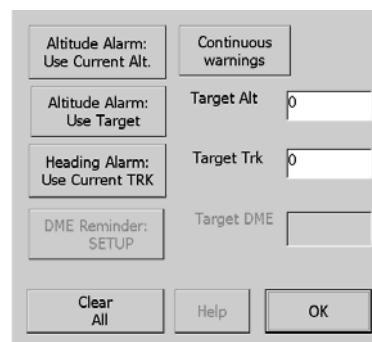

You can either use current altitude or set an altitude target. You set the current heading and a target heading 'bug' triangle displays at the top of the screen showing you the allowable heading deviation window.

Once the aircraft has strayed from course far enough for the 'bug' to exceed the limits, an alarm will sound and an alert box will remind you of the deviation. To shut off Flight Following, simply tap Clear All.

 This function allows you to modify a flight plan right on the map by dragging the course line to a new point and "dropping" it. The point at which you drop the course line becomes a new waypoint in the flight plan. When you activate this mode, a red circle will appear at each waypoint that is currently in the flight plan. Each segment (leg) of the flight plan course will have a thin blue circle positioned about half way along it. You drag and drop these circles to modify the flight plan in the following ways:

Modify an existing waypoint: Drag a red circle to move a waypoint. The original waypoint will change to the new point at which you drop the red circle.

Add a waypoint: Drag a blue circle to insert a waypoint. Once you begin dragging a blue circle, a waypoint will be created wherever you drop it.

Delete a waypoint: Drag the red circle that represents the waypoint you want to delete to either the red circle for the waypoint before or after the one you're deleting. Drop it on top of the red circle before or after, and the waypoint will be deleted.

Log Book... After a flight, log it by double tapping on the timer block in the display.

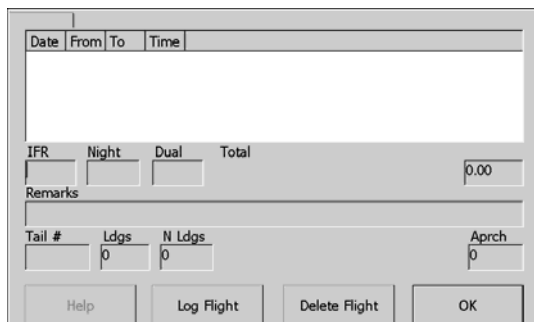

Tap **Tools** + **Log Book...** to call up the logbook screen which already knows the aircraft tail number, type, date of flight, and flight duration. Tap Log Flight and allocate the flight time between day and night, and IFR and VFR conditions of flight, then tap Record. This data is now saved to the memory of the PDA and may later be transferred to your desktop computer to be printed and stored.

Log Flight... After a flight, log it by tapping on this menu item. The time, date, etc. will be saved in the log book.

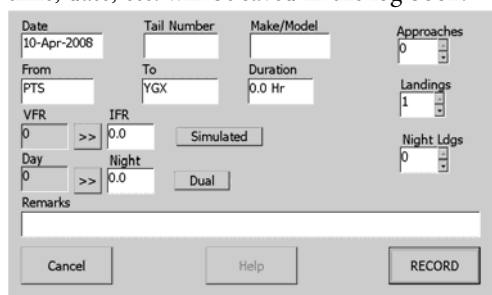

Odometer/ Tripmeter... This screen contains the two trip odometer resets that can be used to track total distance flown for a flight and for each leg. Resets automatically each time the program is started.

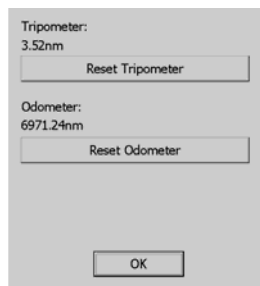

User Waypoints... Delete WP: To delete a waypoint, first select the waypoint in the Select user waypoint screen. Tap the Delete WP button. A screen will pop up asking you Erase user waypoint? Tap Yes, this will bring up the Create/Edit User Waypoint screen with all of the boxes blank. Tap OK, this will bring you to the main map screen. The waypoint has been deleted. If waypoint cannot be deleted, make sure it is not in use in a flight plan on the screen.

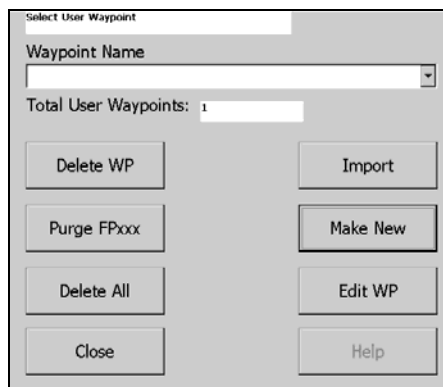

Import WP: Anywhere Map accepts Garmin WPT (Waypoint) files. They become user waypoints in the map system and may be used as any user waypoints. Select the desired file from the list on the screen, tap OK and the waypoints will be read into the map system. A maximum of 1,000 user waypoints is allowed. If you wish to exceed that number, you'll need to break the data into multiple files.

Purge FPs: To delete all of the FPxxx waypoints in the system, simply tap the Purge FPxxx button. These files are created when the user uses the Direct To feature; it is the point at which you are at the time you say Direct To.

Make New WP: Tapping the Make New button on the Select User Waypoint screen will bring up the Create/Edit User Waypoint screen. To create a waypoint at your current location, simply tap CURRENT LOC. This will place the latitude and longitude in the appropriate boxes on the screen. You can also manually enter the desired Lat/Long so the point can actually be saved and added to your flight plan before you arrive at that point. To name the waypoint, tap in the Name box, and enter a name in the box.

Delete All WP: Tapping the Delete All button will delete ALL of the user waypoints in Anywhere Map. When this button is pushed, a box comes up that says Erase ALL user waypoints? Tapping Yes on this screen will erase all user waypoints. Tapping No on this screen will take you back to the Select User Waypoint screen. The changes will take place when you tap OK on the Select User Waypoint screen and return to the Main Map screen.

Edit WP: By tapping the Edit WP button on the Select User Waypoint screen, you may edit user waypoints in Anywhere Map. First select the waypoint you want to edit in the Waypoint Name box, tap Edit WP. This will bring up the Create/Edit User Waypoint screen. You may change any of the information in the text fields, including Name, Comment, Latitude, Longitude, Range and Radial.

Setup HSI... Allows you to use the HSI for guidance to Airports, nav aids, or along your flight plan segments.

Even without a flight plan you can use the HSI to guide you to an airport or Navaid along a specific radial that you prescribe. For example, you may be approaching an airport from the west but want to intercept and track inbound to it on the 220 (SW) degree radial, just as if there were a VOR on the field.

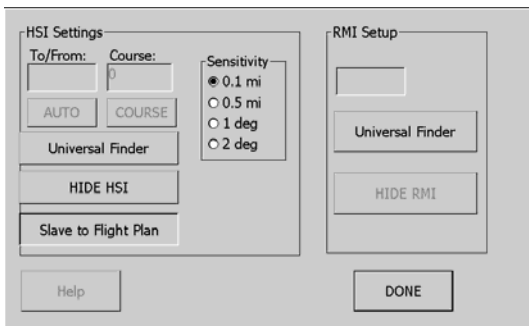

Check “Slave to flight plan” to cause the HSI course arrow to automatically align with the flight plan segments. Tapping Universal Finder pops up the Universal Finder window so you can search for any type of navigation point to use for the HSI.

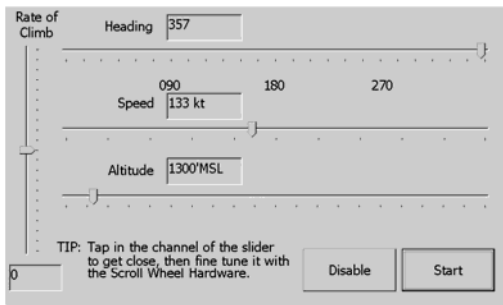

Once a “target” (Airport or Navaid) has been selected, the COURSE and AUTO buttons are enabled. Tap COURSE to pop up a screen that allows the HSI needle course setting to be entered. Tap AUTO to set the course to the radial that the aircraft is currently on relative to the target. Hide will cancel the display of the HSI needles. The Sensitivity selection sets the value of “one dot” of needle deflection on the HSI.

For VORs and NDBs you can set a specific radial to track to/from the Navaid by double-tapping the Navaid on the screen and then checking the Enable box and specifying the radial/course to use. The RUNWAY button is used to activate the virtual ILS function.

Sim Mode...

Sim Mode allows you to ‘fly’ a flight plan from your desk or couch for practice. Tapping this button will bring you to a new screen where you can enter your desired simulation altitude, heading, and speed. Click >Start to begin, or tap Disable to turn Sim Mode off.

Search Grid...

The search grid is a handy tool for creating a consistent grid to fly in a search and rescue mission. To set the grid, first establish the location of the starting point using the latitude / longitude entry screen. This is reached by tapping Set Location. See Latitude / Longitude Input screen for details.

Leg Length: This is the length of each leg of the search grid.

Total Width: This sets the total width of the search area and spans from the first leg to the last leg.

Track Spacing: This specifies the distance between legs for the grid.

Initial Course: This is the direction of the first leg. Of course, each return leg will have the reciprocal course and each cross leg will be 90* from the search legs.

Create: Once the parameters for the grid are set, tap Create to generate the grid.

To remove the grid, go to the Flight Plan Screen, tap the File tab, then tap Clear. The grid will be removed from the map.

Weight & Balance...

This section allows you to set up the arms for your aircraft and then lock them so each flight is simply a matter of entering the weights associated with the flight.

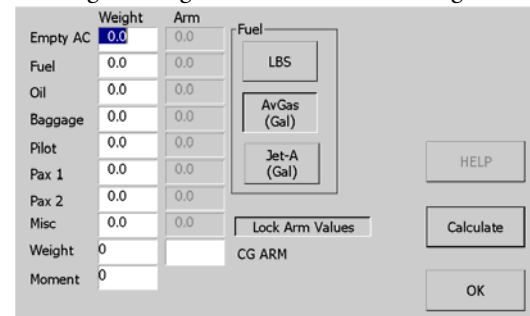

First, uncheck the Lock Arm box so arm values can be entered.

Next, using your Pilot’s Operating Handbook plus any supplemental weight information from the aircraft’s Weight & Balance certificate, fill in the Arm items for each applicable part of your airplane. Calculate fuel in pounds (gallons x 6) or check the appropriate radio button.

If your aircraft’s basic empty weight includes a full load of oil, leave the field blank. Some older aircraft refer to Licensed Empty Weight that does not include drainable oil. In this case, it must be added in the Oil Quarts field. Oil weighs 7.5 lbs per gallon, or 17/8 lbs per quart. After filling in the fields, tap Lock Arm again to preserve the arms.

Now enter the weights for each parameter for the flight you are about to take. Tap Calculate to get total Weight, Moment and Center of Gravity arm (CG ARM). Use the CG ARM value on your Center of Gravity envelope chart found in the P.O.H.

Note: The weight and balance settings are saved as part of the aircraft profile that is created and saved in Aircraft Settings. So when you set up an aircraft (especially if you will use Anywhere Map in more than one airplane) make sure you set up the weight and balance data for the airplane BEFORE you save the aircraft profile.

Note: this button will always return you directly to the main Map screen.

Airport Data Screens: Double tapping on an airport, or searching by ident through Universal Finder will open up the Airport Data Screen. This screen has 8 different tabs across the top which host a wealth of information about the facility.



The first tab provides runway data, field elevation, range/bearing from your current GPS position, and a 'stick' layout of the runways. Tapping the red feather icon will extend the centerlines of the runways on the map screen. Tapping the 'D' icon will open the Taxi Express, GPS enabled diagram of the airfield. See *Using Taxi Express* section on page 31 for more information on this powerful safety feature.



The second tab provides the appropriate COM radio frequencies, AWOS phone number, and Localizer frequencies (if available) for the selected airport.

The third tab contains airport remarks.



The fourth tab contains FBO facility information.



The fifth tab contains current fuel pricing information for each fuel providing FBO on the field. The fuel prices and FBO facility information are updated via the Download Center at www.anywheremap.com



The sixth tab displays local restaurant and hotel information. Most facilities listed are located either on the field, or within 1 mile.



The seventh tab offers a list of Virtual Approach Procedures. These are a top-down view of the approach path with automatic VNAV assistance. These are NOT part 91 approved plates, but instead act as an excellent situational awareness tool on arrival to the selected airport even if the field doesn't offer any actual published approach procedures.



The eighth and final tab displays the raw/undecoded METAR and TAF delivered through the XM Satellite Weather broadcast.



Taxi-Express™ displays an aircraft's GPS position on an airport diagram during taxi operations. This brings pilots an added measure

of safety at airports they are unfamiliar with or during night operations.

The Taxi-Express chart lets you monitor ground position while communicating with Tower and Ground as well as other aircraft. Taxi-Express charts are derived from FAA Terminal Procedures. Taxi-Express is built into the ATC.

USING TAXI-EXPRESS:

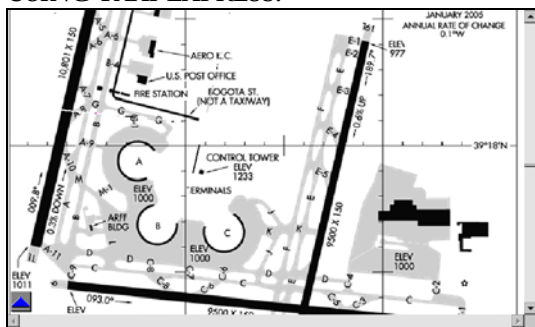

1. Select an airport and open its Information screen.

Double-tap the runway diagram in the top right corner of the Airport Info screen.

The Taxi-Express diagram appears and will show your live GPS position over it if you're near the field.

A soft blue 'up arrow' key in the lower left corner of the diagram produces a menu when tapped that'll allow you to 'Zoom to Fit' the diagram to the screen. This menu also contains the 'close diagram' button which will return you to the Map screen.

SETTINGS MENU:

Tapping + will take you to the second menu page that looks like this:



AIRCRAFT SETTINGS:

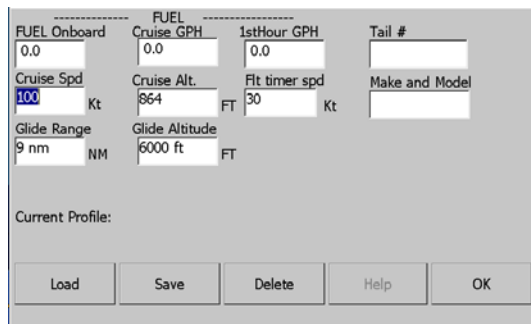
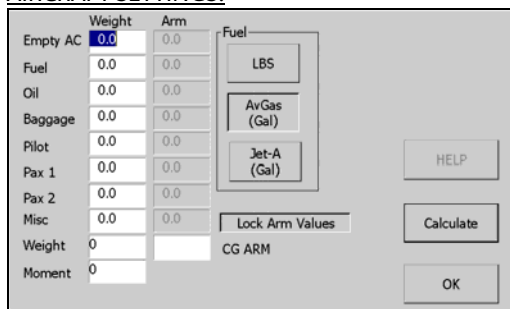

An aircraft profile saves all of the settings that are tied to a particular aircraft in a single file that can be loaded and saved to the file system of the Pocket PC. This is very convenient for the pilot who flies multiple aircraft.

The following information is saved in an Aircraft Profile:

All of the information on the Aircraft Settings Screen: + + Aircraft Settings.

All of the information on the Weight and Balance Screen: + + Weight & Balance.

To create an aircraft profile, set up the values in the Aircraft settings screen, as well as the weight and balance screen as desired, and tap the SAVE button in the aircraft settings screen. This will pop up a screen that allows you to name the aircraft settings file. In most cases the default name, which will be a combination of the aircraft make and model and tail number will suffice.

To load an aircraft profile, go to the Aircraft settings screen, and tap the LOAD button. This will pop up a list of stored aircraft profiles on the system. Double tap on any entry or tap once and tap OK to select it.

These parameters are used for flight plans, Cones of Safety, and flight timer operation. In addition, when you save the profile, the weight and balance data currently in use are also saved under this aircraft profile making them easily usable on subsequent flights.

Fuel onboard: This is the total usable fuel on board in gallons.

Cruise GPS: This is the average fuel burn in gallons per hour for the enroute portion of the flight other than the first hour.

1st Hour GPS: This is the first hour fuel burn which is normally a bit higher than cruise due to the high power settings associated with take off and climb.

Cruise Speed: This is the normal cruise speed in knots. You can enter this as True Airspeed if you use winds in the flight plan to compensate. Otherwise you can use an average ground speed (considering winds separately) and disregard using winds in the flight plan.

Cruise Altitude: Cruise Altitude is the altitude used for Sim Mode operations and for displaying Cones of Safety when a GPS is not connected. This is overridden by the GPS altitude when in flight.

Flight Timer: This is the speed at which you want the flight timer to automatically initiate. Usually this is set at a speed faster than taxiing, but less than rotation speed so the timer starts on the takeoff roll.

Cones of Safety:

Glide Range: These parameters set the Cones of Safety calculation. By setting the glide ratio, the Cones of Safety can be sized properly.



Glide Altitude: The altitude from which the glide range can be achieved.



Remember, the Cones of Safety are NOT compensated for winds at any altitude. They are merely an assistance to making a good forced landing decision but the pilot MUST account for wind in the final airport decision.

Load, Save, Delete: These allow the aircraft profile to be saved (takes you to the profile list screen), loaded (also goes to the profile list screen) from the existing list, and deleted from the system. Weight and balance data is saved with the profile.

Cones of Safety: Around each airport there is a region of airspace from which an airplane can safely glide to a landing. We refer to this space as the Cone of Safety.

The Cones of Safety are represented by a thin green circle around each airport. In the night mode, the Cones stand out against the dark background. The circle's diameter varies with the aircraft's altitude above the field and with the pre-set glide performance.

To set up the Cones of Safety, you must first go to  +  + Aircraft Settings enter in the glide ratio of the aircraft into the appropriate boxes. You can usually find this information in the

POH. Once you have entered this information in the appropriate boxes, then go to:  + View Settings + APT Tab. Place a check mark in the box next to Cone of Safety. The cones will now be shown around all airports. If they are not, it is because the aircraft is sitting on the ground or, if no GPS is attached, the map "thinks" the aircraft's altitude is below that where the CoS are visible. To check this go to:  +  + Aircraft Settings and set the Cruise Altitude to some value above 3000' for example. The green CoS circles should now show on the map around each airport.

Caution: The Cones of Safety are not compensated for wind. It is wise to stay away from the down-wind side of the cone. The Cone converges on a "reference point" of the airport, generally the center of the airfield. In other words, do not continue to use the Cone of Safety when you are trying to land, but rather concentrate on the task at hand.

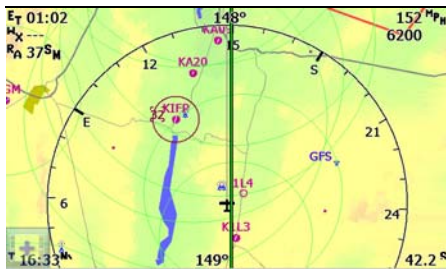

GPS Settings: Allows you to configure several parameters pertinent to the GPS including an output port for the GPS data/steering corrections for integration with an auto-pilot in an experimental aircraft. This feature is only available when using the BlueLink Autopilot adapter available from Control Vision. The instructions for configuring this feature are included with the adapter.

Checking the "Lock Heading below 2 MPH" box on this screen will enable enhanced stability of the map screen while sitting still on the ground.

Timer Settings: Allows you to setup or clear the different timers available in the ATC. "Reset FT" button will clear the Flight Timer. The Flight Timer is also cleared automatically when the Anywhere application is closed and reopened. "ET Countdown" provides a field where you can enter a time value to count down from rather than standard stopwatch function. This screen also allows you to set the minimum speed that you want the Flight Timer to start.

Bluetooth Manager: This button launches the Bluetooth browser in the ATC. This browser gives you the ability to connect to the WX Worx receiver box. Follow the onscreen commands to link up, then click the 'back/return to map' screen to resume navigation. See *Using XM Weather* on page 33 for more details on WX receiver connection through Bluetooth.

XM Status: Allows you to view the statistics of the active XM WX connection. The total count of weather files received and the age of the most current file are displayed here. A 'quick' view of this screen can be called up right from the map screen by tapping the WX status line in the top left one time. This screen will come up by double tapping on the same area.

XM Radio: Allows you to tune the audio channel and adjust the volume level in the WX Worx Dual Ensemble receiver that is connected through Bluetooth to the ATC. The audio signals are output directly from your WX Worx receiver through an optional cable which connects to your compatible headset or entertainment jack in the audio panel. This feature requires an additional (to your WX data subscription) monthly subscription to XM Satellite Weather.

XM Settings: Shows the connection status of the WX box and gives you access to manually open the "Advanced" / Receiver Activation screen manually. You should never need to visit this screen unless advised by Technical Support.

Color Tables: 3 different buttons give you the ability to launch the XM weather color keys over the map screen.



Shows relative colors (in gray) of the IR Satellite Imagery with dark charcoal being the lowest cloud top and light purple being the highest.



NEXRAD COLOR CHART

Shows colors of the NEXRAD for relative storm intensity from green being the lowest precipitation intensity and magenta the highest.



ECHO TOPS COLOR CHART

Shades of gray denote the highest altitude at which a radar return was received in that geographic tile. In other words, this shows the tops of the radar returns. This is NOT necessarily the tops of the clouds! For example, you could have a very large area of clouds that go from 2000' AGL to FL120. The IR Sat shows the tops of the clouds at FL210 using the appropriate color coding for that altitude. There is precipitation and it shows on radar. But the precipitation does not begin at FL210. Instead, the precip begins at 17,000'. So the color coding of the EchoTops would be for the lower altitude. In addition, EchoTops, being a radar product, are not filtered like the color-coded radar is at the bottom (low intensity) end of the scale. That means that an EchoTops will show all precip regardless of intensity where the radar will only show precipitation from a certain level of intensity upward. EchoTops, therefore, give you a clue to things that are happening but that do not yet show up on radar. This is especially handy in convective situations where EchoTops "fill in" the gaps between storm cells painted by radar. When you see this, you can expect convective activity (at least bumps) in that area even though radar does not paint any colors there. You may want to go around the area of the two cells instead of between them, when you see this situation.

Using XM Weather:

The ATC will connect automatically to an ATC configured XMWX weather receiver. The ATC will not connect to third party XMWX receiver units, even if they are Bluetooth equipped.

XM weather can be enabled or disabled in the XM Settings screen (TOOLS > SETTINGS).

XM may be disabled for those days when you have no need to check the weather. If no compatible XM weather box is found in the automatic search sequence, XM will be automatically disabled and may be re-enabled at any time.

When XM is enabled the first time, your ATC will look for any compatible XMWX receiver.

After you connect the ATC to a particular XMWX receiver, the ATC will remember that radios unique ID code and will automatically try to reconnect to that receiver in the future.

This is referred to as being PAIRED with a receiver. Your ATC can only pair with one receiver at a time, however it is a very simple process to pair it with any receiver at any time.

Connecting with a PAIRED receiver

Under normal circumstances, your ATC will be paired with a XMWX receiver. This connection process is automatic and takes place in just a few seconds. The power to the Bluetooth radio

system is controlled automatically. When Anywhere Map is launched from the ATC startup screen, the Bluetooth radio is enabled (powered up) by the Map software. If the ATC detects the paired receiver on power up, the Bluetooth connection with this device will automatically be established as the software starts up. If the Bluetooth radio in the ATC is off (no blue LED) the software will automatically start the Bluetooth system, this may take 15-30 seconds. The actual connection takes only a fraction of a second to establish. The XM Status area of the map screen will show each step as it happens...

BT ON < Please Wait> C O NNECT INIT ACT CHK REQST SIGNAL

The map is frozen for 15-30 seconds while the Bluetooth is being turned on (the first two steps).

This happens only when starting Anywhere Map or whenever the ENABLE XM button is pressed. The other steps may take another 15-30 seconds to complete, but they happen in the background as you use the map. Some of these steps may happen so quickly that they do not always show up in the XM status area. Once the XM connection progresses to the SIGNAL STRENGTH state, weather files can begin being received.

If the matching XMWX weather radio is not detected within a short time, the XM weather status in the ATC is switched to NORADIO and this value is displayed in the upper left corner of the screen, and the system stops searching for the missing radio. The status of the XM weather system is set to DISABLED. At this point, the Bluetooth radio is also shut down to save power.

This results in the blue LED going dark.

Manual Connection

To later connect to a Bluetooth XMWX receiver, simply power up the weather receiver, and go to the TOOLS > SETTINGS > XM Settings screen, and press the ENABLE XMWX button.

This will cause the Bluetooth connection process to be repeated and the connection process will be repeated, exactly as above.

XM Activation and Refresh

In order to use an XM weather receiver, your radio must be "activated" by a special signal from the XM radio satellites. This step is normally completed for you at Control Vision before the XM radio is shipped. However, your XM radio may "lose" its activation from time to time due to inactivity. This circumstance is usually evidenced by the Wx status in the upper left corner of the screen showing ACTXM, followed by the XM Radio Activation window opening automatically:

Radio ID: If the Radio ID is shown at the top, then you have a good Bluetooth connection. Continue down the items below. If you do not see the Radio ID, then please power down your system and restart it. If this screen reappears and you still don't see the Radio ID, then call Anywhere Map Technical Support.











Signal Strength: If the signal strength is GOOD (3 green bars), then your antenna is properly installed and "seeing" satellites. If signal strength is Fair or Poor, move the antenna (or turn the airplane) until it shows GOOD. This is critical to proper operation. If the

signal strength is NOXMSAT, then either your antenna is not connected properly, you have a bad antenna, or the antenna is completely out of view of the satellites (the plane is in the hangar).

XM Status: If the Status shows None, then your unit has probably lost activation. Call XM (800-985-9200), give them the Radio ID and ask them to refresh the radio for you. Your unit **MUST** be running and displaying this screen for the reactivation to work! Within about 10 minutes after XM initiates the refresh, you should see codes on this line: “M1” for Aviator Lite or “M128” for Aviator. You may see a 0 or 3 there as well. This is no problem.

XM Activation: Once the codes in XM Status begin appearing, this line will change from “Not Activated” to “Partially Activated”. Once the proper codes are received, this line will show “Aviator Lite” or “Aviator”. Now simply tap DONE and you will return to the map where the XM unit will reinitialize as normal. The activation process is one in which your receiver’s identification code is sent down to the radio over the XM satellites. The receiver then stores this activation code internally for a certain time period. If you fail to keep your subscription up to date, the receiver will be deactivated and will no longer operate until it is activated by XM again. Note that to activate your radio use this screen, you must have your XM radio receiver module connected and the antenna in an area of good reception.

METARS and TAFS

Ceiling	Visibility
>10000 ft. 	>10 mi. 
>3000 ft. 	>5 mi. 
1-3000 ft. 	3-5 mi. 
500-1000 ft. 	1-3 mi. 
<500 ft. 	<1 mi. 

Anywhere WX delivers weather information originating with the National Weather Service and broadcast by XM Satellite Weather. Included are two types of text reports: METARs which are scheduled hourly observations, and TAFs which are forecasted conditions at an airport usually during a 24 hour period.

Graphical METARs can be ‘read’ first by color. The top color indicates ceiling while the bottom color is for visibility.

Blue indicates high VFR conditions.

White indicates VFR conditions.

Yellow indicates Marginal conditions.

Red indicates IFR conditions.

Magenta indicates Low IFR conditions.



The above graphic: now would indicate IFR ceiling, with Marginal visibility.

Single-tapping a reporting airport or one associated with a graphical METAR on the map screen will give you a ‘quick/translated’ view of the METAR showing Altimeter, Temperature, Dewpoint, Ceiling,

Visibility and Wind direction and Speed. Double tapping the airport and then tapping the WX tab in the Airport Information Screen will open the full UNDECODED METARS showing the full coded text METAR as created by the NWS.

Updating ATC

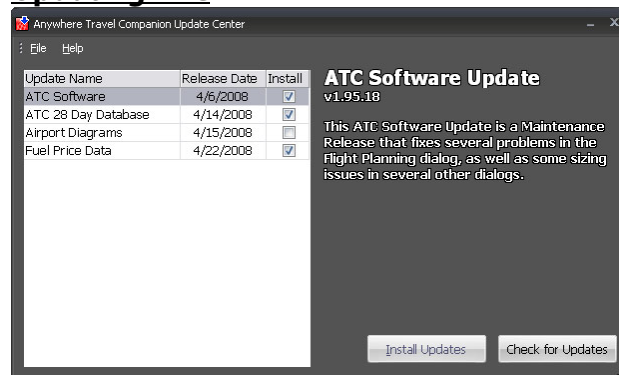

The ATC can be connected to your desktop, laptop, or tablet PC running Windows 2000, NT, XP, or Vista for updates. Before any updates can be installed, you must register the ATC Product Activation Key. This key can be found on a silver sticker located under the battery cover of the ATC and also on your invoice.

Register this code online at:

<http://www.anywheremap.com/registration/>

After registering you’ll need to download and install the Update Center. The Update Center (UC) application manages all software and database upgrades for your ATC by automatically downloading the information and will prompt you when ready install to the ATC device itself. The UC application can be downloaded from <http://updatecenter.anywheremap.net>

If you are prompted to install Visual Studio Redistributable, do so, but it is not necessary to restart your PC when prompted, you should wait until the Update Center is fully installed.

After installation, the Update Center can be found in Start>All Programs>Anywhere Map>Anywhere Update Center. Double click on it and it will place an icon in the system tray down by the clock. Double-clicking the icon will open up the main window. The first time you run Update Center, you will need to go to File>Settings and enter your User Name and Password (twice to verify it).

Exit out of AWM so that on the ATC you see the three main icons. Connect the ATC with the supplied USB cable, you will see a sync icon on the ATC.

Clicking the button “Check for Updates” will make the UC check the server for any new chart databases, TFR/SFRs, Airport/FBO facility directory, Fuel Prices, software upgrades, and/or other updates since your last upgrade. Select Yes when prompted to download the updates.

When the downloads are complete, click “Install Updates” to begin upgrading the ATC with the updates you just downloaded.

Once complete, disconnect your ATC from the PC and press in the reset button (found on the right side of the device). You are now ready to use the ATC with the current updates.