

Series 103

User's Manual



On/Off Temperature Controller



**TOTAL
CUSTOMER
SATISFACTION**
3 Year Warranty

ISO 9001



Registered Company
Winona, Minnesota USA



1241 Bundy Boulevard, P.O. Box 5580, Winona, Minnesota USA 55987-5580
Phone: +1 (507) 454-5300, Fax: +1 (507) 452-4507, Internet: <http://www.watlow.com>

0600-0004-0007 Rev D
January 2001
Supersedes: 0600-0004-0007 Rev C

\$5.00 Made in the U.S.A.
Printed on Recycled Paper
10% Postconsumer Waste



General Description

The Watlow Series 103 is a DIN rail mount, on-off temperature controller with a thermocouple or RTD sensor input. The DIN rail mounting offers quick and easy installation with the use of simple hand tools. The controller may also be flush mounted.

The Series 103 can be factory configured as either a heat or cool output. Output types include electromechanical relay, solid-state relay or open collector output.

The Series 103 has an LED for output status indication and can be ordered with an integral, adjustable set point or a fixed set point.

Specifications

(2001)

Control Mode

- On-off
- Nominal switching hysteresis, typically 3°F (1.7°C)

Operator Interface

- LED indication of output status
- Dial scale calibrated to compensate for sensor non-linearities
- Integral set point
 - Dual temperature scale (°F and °C)
- Fixed set point
 - Manufactured to specified value

Input

- Thermocouple or platinum RTD available
- Thermocouple with automatic cold junction compensation
- Thermocouple may be isolated or grounded
- Thermocouple and RTD break protection de-energizes output
- 2- or 3-wire RTD input, 100Ω, 500Ω or 1000Ω @ 0°C calibrated for 0.003850Ω/°C curve, factory selectable

Output

- Solid-state relay, Form A, 0.5A @ 24V~ min., 264V~ maximum, opto-isolated, zero cross switching
- Switched dc signal provides a non-isolated minimum turn-on voltage of 3V~ (dc) into a minimum 500Ω load, maximum on voltage not greater than 32V~ (dc)
- Electromechanical relay, 8A, Form C, SPDT: 8A @ 240V~ resistive, 8A, 28V~ (dc) resistive, 275 VA pilot duty rated

Accuracy

Adjustable Set Point

- Calibration accuracy: ±1% of span, at 77°F ±5°F (25°C ± 3°C) ambient and rated line voltage ± 1%
- Set point accuracy: ±3% of dial scale
- Accuracy span: 1000°F (540°C) minimum

Fixed Set Point

- Calibration accuracy: ±10°F/±6°C of setting, at 77°F ±5°F (25°C ±3°C) ambient and rated line voltage ±1%

Temperature Stability

- Thermocouple: Typically 5μV/°F ambient (9μV/°C ambient) input referenced
- RTD: Typically 0.2°F/°F ambient (0.2°C/°C ambient)

Voltage Stability

- ±0.01% of span (min span of 1000°F or 540°C) per % of rated line voltage

Agency Approvals

- CE: EN61010 - Safety
EN61326 - Industrial Immunity, Class B Emissions
Installation Category 2, Pollution Degree 2
- 873, File #E43684
- to C22.2 No. 24, File #E43684
- Approved for use in commercial cooking applications

Terminals

- Captive screw, cage clamp connection, 0.155 in. (4mm) max. width screwdriver blade, 30 to 14-gauge wire

Mounting

- DIN rail, DIN EN50022, 35mm x 7.5mm
- Sub-panel mounting

Power

- 120V~, +10%/-15%, 50/60 Hz
- 230V~ to 240~, +10%/-15%, 50/60 Hz
- 10VA maximum power

Operating Environment

- 32 to 131°F (0 to 55°C)
- 0 to 90% RH, non-condensing
- Storage temperature: -4 to 185°F (-20 to 85°C)

Dimensions

- Width: 2.28 in (60 mm)
- Height: 4.45 in (115mm)
- Depth: 3.89 in (100 mm)

Weight

- 0.7 lb. (0.3kg)

UL® is a registered trademark of Underwriter's Laboratories, Inc.
Note: Specifications subject to change without notice.

Dimensions

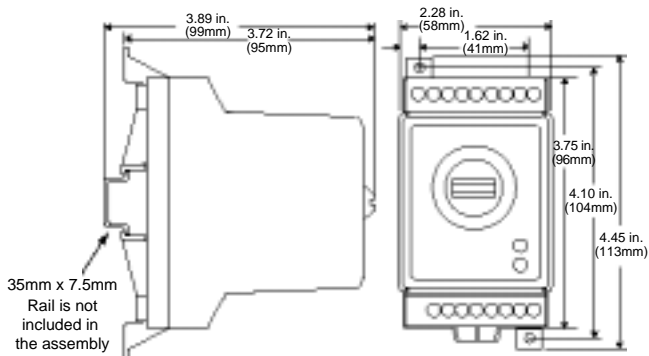

Figure 2a — Series 103 dimensions.

Installation

Sub-Panel Mounting the Series 103

1. Using the controller as a location template, mark both mounting holes.
2. Drill two 0.19 in. (5mm) diameter holes in the desired panel location. See Figure 2a for hole locations.
3. Mount the Series 103 using two #8-32 screws.

DIN Rail Mounting the Series 103

1. Place the Series 103 upper mounting clip on the top edge of the DIN rail. See the Figure 2b on this page.
2. Press down firmly on the top front edge of the Series 103. The control “snaps” securely onto the rail. If the control does not snap on, check to see if the DIN rail is bent. Minimum clipping distance is 1.37 in. (34.8mm), the maximum is 1.39 in. (35.3mm).

Removing the Series 103 from the DIN Rail

1. Place your fingers on the release lever located at the base of the Series 103.
2. While gently pressing on the top of the case, above Terminals 1 to 9, pull forward on the release lever.

Safety Information

Note, caution and warning symbols appear throughout this book to draw your attention to important operational and safety information.

A “NOTE” marks a short message to alert you to an important detail.

A “CAUTION” safety alert appears with information that is important for protecting your equipment and performance.

A “WARNING” safety alert appears with information that is important for protecting you, others and equipment from damage. Pay very close attention to all warnings that apply to your application.

The  symbol (an exclamation point in a triangle) precedes a general CAUTION or WARNING statement.

The  symbol (a lightning bolt in a triangle) precedes an electric shock hazard CAUTION or WARNING safety statement.

Mounting

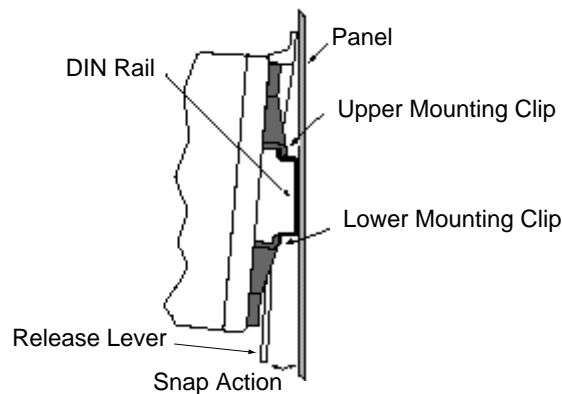

Figure 2b — Series 103 side view mounting.

Wiring Guidelines

- Use the correct sensor type per the model number on the unit sticker.
- Use the proper thermocouple or RTD polarity.
- Insulate the thermocouple mounting from the mounting surface to prevent heat migration input errors.
- Thermocouple leads should be twisted pair wire and routed separately from any other lines.
- In electrically noisy environments (heavy switching of contactor, motors, solenoids, etc.) use shielded thermocouple lead wire with the shield connected at the sensor end only.
- All wiring and fusing must conform to the National Electric Code (NEC) NFPA70 and any other locally applicable codes.
- Fuse the independent load voltage on the L1 (hot) side and connect it to the common (COM) side of the relay.



CAUTION: A power disconnect switch located near the controller is recommended to shut down power in case of controller failure.

- Long lead lengths create electrical resistance. When using a two-wire RTD, there will be an additional error for every 1Ω of lead length resistance. That resistance when added to the resistance of the RTD element, can result in erroneous input to the temperature controller. To overcome this problem, use a three-wire RTD sensor, which compensates for lead length resistance. When extension wire is used for a three-wire RTD, all three extension wires must have the same electrical resistance (i.e. same gauge, copper stranded).

Power Wiring

120V~ 103_ **1** _ _ _ - 0000

230 to 240V~ 103_ **2** _ _ _ - 0000

NOTE: The line voltage is specified by your model number.



WARNING: To avoid potential electric shock, use National Electrical Code safety practices when wiring and connecting this unit to a power source and to electrical sensors or peripheral devices. Failure to do so could result in injury or death.

All wiring and fusing must conform to the National Electric Code and to any locally applicable codes.



CAUTION: Applying incorrect voltage may result in irreversible damage to the control.

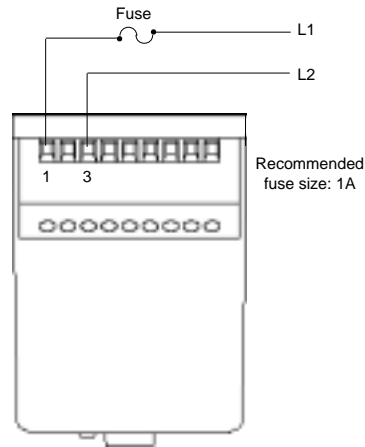

Figure 3a — Power wiring.

Input Wiring

Thermocouple

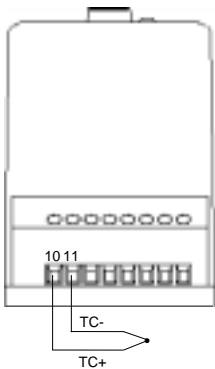

Figure 3b — Thermocouple wiring.

2- and 3-wire RTD

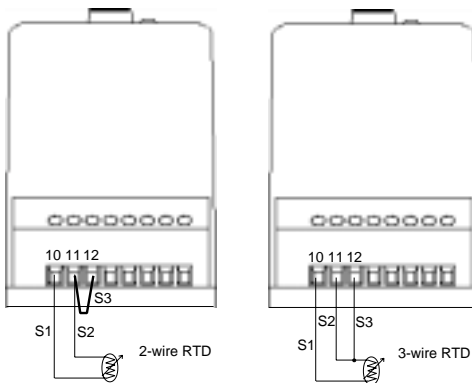

Figure 3c — 2- and 3-wire RTD wiring.

NOTE: 2- or 3-wire RTD input, calibrated for 0.003850Ω/Ω °C curve.

Output Wiring

Electromechanical Relay, Form C without contact suppression

10A 103 **E** - _ _ _ _ - 000

Solid-State Relay, Form A, 0.5A without contact suppression

5A 103 **K** - _ _ _ _ - 000

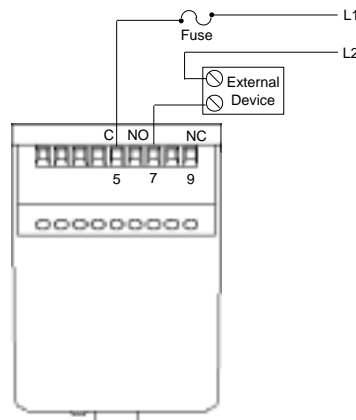

NOTE: We strongly recommend that all control loops use an approved temperature limit for over or under temperature limit protection.



WARNING: Failure to install a temperature limit for protection where a potential hazard exists could result in damage to equipment and property wiring and injury to personnel.

Figure 3d — Electromechanical and solid-state relay wiring.

NOTE: Switching inductive loads (relay coils, solenoids, etc.) with the mechanical relay, switched dc or solid-state relay output options requires use of an R.C. Suppressor. Watlow carries the R.C. suppressor Quencharc brand name, which is a trademark of ITW Paktron. Watlow Part No. 0804-0147-0000.

Switched DC

103 **C** - _ _ _ _ - 000

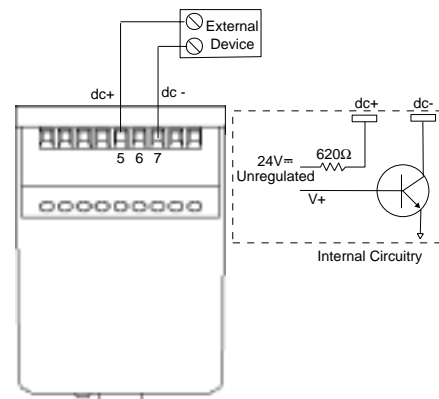

Figure 3e — Switched dc

System Example

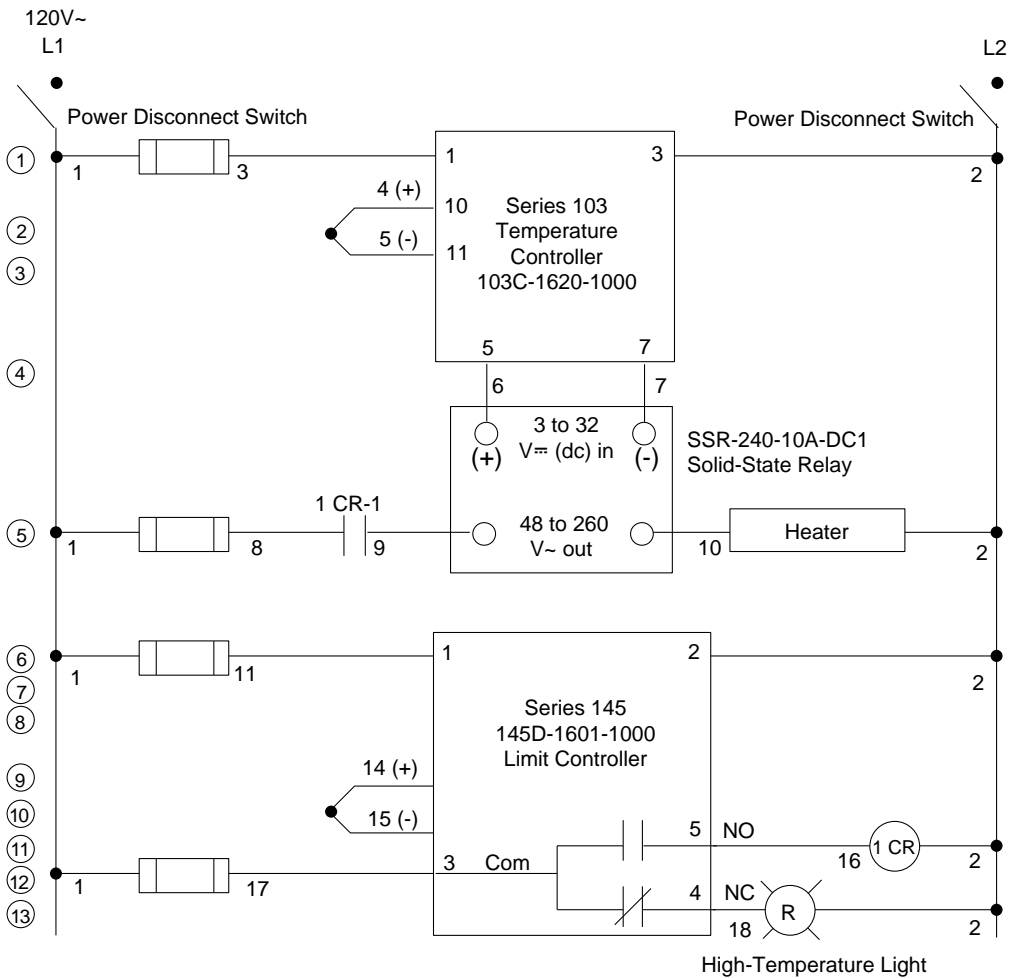
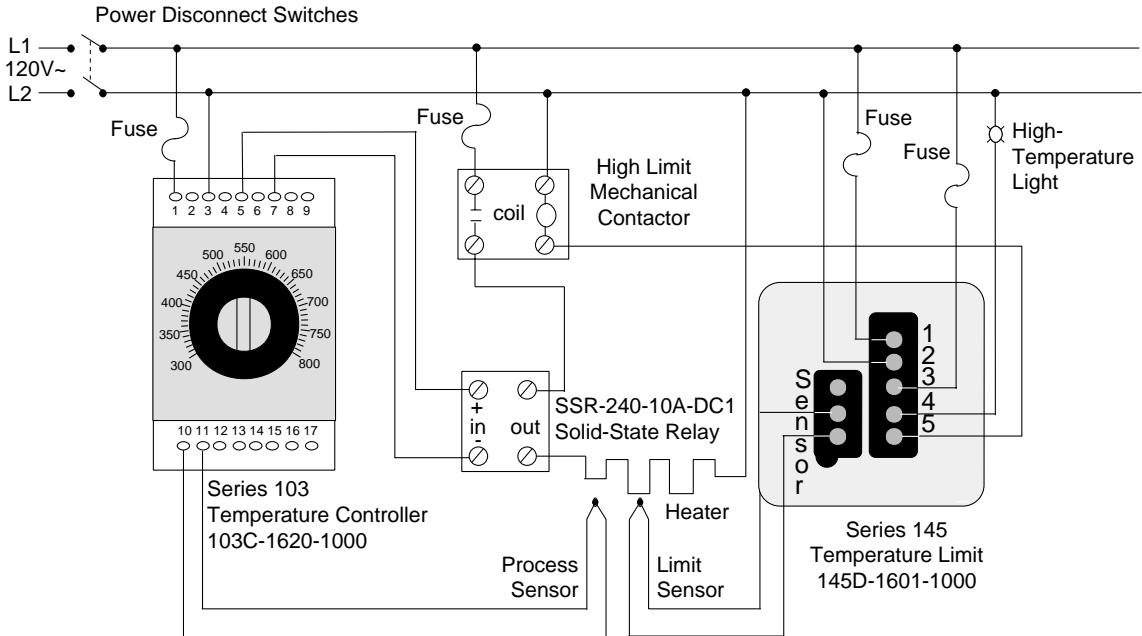

Figure 4 — System wiring examples.

Declaration of Conformity

Series 103



WATLOW WINONA

1241 Bundy Boulevard

Winona, Minnesota 55987 USA

Declares that the following product: **English**

Designation: Series 103
Model Number(s): 103(C, E or K) - (1 or 2) (100-999)-(1 or 2) (any 3 letters or numbers)
Classification: Installation Category II, Pollution Degree II
Rated Voltage: 120 or 240V~

Rated Frequency: 50/60 Hz
Rated Power Consumption: 10VA maximum

Meets the essential requirements of the following European Union Directive(s) using the relevant section(s) of the normalized standards and related documents shown:

89/336/EEC Electromagnetic Compatibility Directive

EN 61326:	1997	Electrical equipment for measurement, control and laboratory use - EMC requirements (Emissions Class B)
EN 61000-3-2:	1995	Limits for harmonic current
EN 61000-3-3:	1995	Limitations of voltage fluctuations and flicker
EN 61000-4-2:	1995	Electrostatic discharge
EN 61000-4-3:	1997	Radiated immunity
EN 61000-4-4:	1995	Electrical fast transients
EN 61000-4-5:	1995	Surge immunity
EN 61000-4-6:	1994	Conducted immunity
EN 61000-4-11:	1994	Voltage dips, short interruptions and voltage variations immunity
ENV 50204:	1995	Cellular phone

73/23/EEC Low-Voltage Directive

EN 61010-1:	1993	Safety requirements for electrical equipment for measurement, control, and laboratory use, Part 1: General requirements
-------------	------	---

Déclare que le produit suivant : **Français**

Désignation : Série 103
Numéro(s) de modèle(s) : 103(C, E ou K) - (1 ou 2)(100-999) - (1 ou 2) (trois lettres ou chiffres quelconques)
Classification : Installation catégorie II, degré de pollution II
Tension nominale : 100 ou 240 V~
Fréquence nominale : 50/60 Hz
Consommation d'alimentation nominale : 10 volt-ampères maximum

Conforme aux exigences de la (ou des) directive(s) suivante(s) de l'Union Européenne figurant aux sections correspondantes des normes et documents associés ci-dessous :

89/336/EEC Directive de compatibilité électromagnétique

EN 61326:	1995	Appareillage électrique pour la mesure, la commande et l'usage de laboratoire — Prescriptions relatives à la Compatibilité Electro Magnétique (Émissions classe B)
EN 61000-3-2 :	1995	Limites d'émission de courant harmonique
EN 61000-3-3 :	1995	Limites de fluctuation de tension
EN 61000-4-2 :	1995	Décharge électrostatique
EN 61000-4-3:	1997	Insensibilité à l'énergie rayonnée
EN 61000-4-4 :	1995	Courants électriques transitoires rapides
EN 61000-4-5 :	1995	Insensibilité aux surtensions
EN 61000-4-6:	1996	Insensibilité à l'énergie par conduction
EN 61000-4-11 :	1994	Insensibilité aux chutes subites, aux courtes interruptions et aux variations de tension
ENV 50204 :	1995	Téléphone cellulaire

73/23/EEC Directive liée aux basses tensions

EN 61010-1 :	1993	Exigences de sécurité pour le matériel électrique de mesure, de commande et de laboratoire, Partie 1 : Exigences générales
--------------	------	--

(2003)

Erklärt, daß das folgende Produkt:

Deutsch

Beschreibung: Serie 103
Modellnummer(n): 103(C, E oder K) - (1 oder 2) (100-999) - (1 oder 2) (3 beliebige Buchstaben oder Ziffern)
Klassifikation: Installationskategorie II, Emissionsgrad II
Nennspannung: 120 oder 240 V~
Nennfrequenz: 50/60 Hz
Nominaler Stromverbrauch: Maximaler 10VA

Erfüllt die wichtigsten Normen der folgenden Anweisung(en) der Europäischen Union unter Verwendung des wichtigsten Abschnitts bzw. der wichtigsten Abschnitte der normalisierten Spezifikationen und der untenstehenden einschlägigen Dokumente:

89/336/EEC Elektromagnetische Übereinstimmungsanweisung

EN 61326:	1997	Elektrogeräte zur Messung, Regelung und zum Laboreinsatz EMC-Richtlinien (Emissions Klasse B)
EN 61000-3-2:	1995	Grenzen der Oberwellenstromemissionen
EN 61000-3-3:	1995	Grenzen der Spannungsschwankungen
EN 61000-4-2:	1995	Elektrostatische Entladung
EN 61000-4-3:	1997	Strahlungsimmunität
EN 61000-4-4:	1995	Elektrische schnelle Stöße
EN 61000-4-5:	1995	Spannungsstoßimmunität
EN 61000-4-6:	1994	Störimmunität
EN 61000-4-11:	1994	Immunität gegen Spannungsgelände, kurze Unterbrechungen und Spannungsabweichungen
ENV 50204:	1995	Mobiletelefon

73/23/EEC Niederspannungsrichtlinie zu entsprechen

EN 61010-1:	1993	Sicherheitsrichtlinien für Elektrogeräte zur Messung, zur Steuerung und im Labor, Teil 1: Allgemeine Richtlinien
-------------	------	--

Declara que el producto siguiente:

Español

Designación: Serie 103
Números de modelo: 103(C, E ó K) - (1 ó 2)(100-999) - (1 ó 2) (Cualquier combinación de tres números y letras)
Clasificación: Categoría de instalación II, grado de contaminación ambiental II
Tensión nominal: 120 ó 240 V~
Frecuencia nominal: 50/60 Hz
Consumo nominal de energía: 10 VA máximo

Cumple con los requisitos esenciales de las siguientes Directivas de la Unión Europea, usando las secciones pertinentes de las reglas normalizadas y los documentos relacionados que se muestran:

89/336/EEC - Directiva de Compatibilidad Electromagnética

EN 61326:	1997	Equipo eléctrico para medición control y uso en laboratorios - Requisitos de compatibilidad electromagnética (Emisiones Clase B)
EN 61000-3-2	1995	Limites para corriente armónica
EN 61000-3-3	1995	Limitaciones de oscilaciones y fluctuaciones de voltaje
EN 61000-4-2:	1995	Descarga electrostática
EN 61000-4-3:	1997	Inmunidad radiada
EN 61000-4-4:	1995	Perturbaciones transitorias eléctricas rápidas
EN 61000-4-5:	1995	Sobretensión
EN 61000-4-6:	1994	Inmunidad conducida
EN 61000-4-11:	1994	Caídas de tensión, interrupciones breves y variaciones de tensión
ENV 50204:	1995	Teléfono portátil

73/23/EEC Directiva de Baja Tensión

EN 61010-1:	1993	Requerimientos de seguridad para equipos eléctricos de medición, control y uso en laboratorios, Parte 1: Requerimientos generales
-------------	------	---

William R. Blaisdell

Name of Authorized Representative

Winona, Minnesota, USA

Place of Issue

Plant Manager

Title of Authorized Representative

May 15, 2000

Date of Issue

Signature of Authorized Representative

Ordering Information

(2002) **103** - - - - **0 0 0**

Output Type _____

C = Switched dc, non-isolated
 E = Electromechanical relay, 8A, Form C
 K = Solid-state relay, Form A, 0.5A

Line Voltage _____

1 = 120V~
 2 = 230V~ to 240V~

Input and Range _____

Type E
 619 = 32 to 1470°F (0 to 799°C)
 Type J
 601 = 32 to 600°F (0 to 315°C)
 602 = 32 to 1382°F (0 to 750°C)
 618 = 0 to 200°F (-17 to 93°C)
 620 = 300 to 800°F (149 to 427°C)
 623 = 110 to 130°F (43 to 54°C)
 624 = 75 to 275°F (24 to 135°C)
 Type K
 603 = 32 to 2282°F (0 to 1250°C)
 611 = 32 to 1112°F (0 to 600°C)
 626 = 60 to 300°F (16 to 149°C)
 627 = 32 to 150°F (0 to 66°C)
 Type T
 629 = -328 to 662°F (-200 to 350°C)
 630 = -22 to 158°F (-30 to 70°C)
 RTD
 101 = -100 to 1112°F (-73 to 600°C)

Control Mode _____

1 = Heat
 2 = Cool

Note: Electromechanical relays are warranted for 100,000 closures only. Solid-state relay switching devices are recommended for applications requiring extended service life.

Note: Outputs with contact suppression should be used with inductive loads.

Note: User documentation may be available in French, German, Spanish, Italian, and Dutch, as well as English. Check Watlow's website (www.watlow.com/) for availability. Specify language at time of order.

Warranty

The Series 103 is warranted to be free of defects in material and workmanship for 36 months after delivery to the first purchaser for use, providing that the unit has not been misapplied. Since Watlow has no control over its use or misuse, we cannot guarantee against failure. Watlow's obligations hereunder, at Watlow's option, are limited to replacement or refund of purchase price of a unit which upon examination proves to be defective within the warranty period. This warranty does not apply to damage resulting from transportation, alteration, misuse or abuse.

Returns

- Call or fax Customer Service for a Return Material Authorization (RMA) number before returning a product.
- Put the RMA number on the shipping label, and also a description of the problem.
- A 20% of net price restocking charge applies to all standard units returned to stock.

Contact

- Phone: 507/454-5300
- Fax: 507/452-4507

Technical Support

If you encounter a problem with your Watlow controller, verify that your wiring is correct for your specific model number. If the problem persists, an Application Engineer can discuss your application with you.

Before calling, please have the complete model number and user's manual available. You can get technical support by dialing 507/494-5656, 7 a.m. to 7 p.m. Central Standard Time. The Series 103 User's Manual is copyrighted by Watlow, Inc., © January 2001, with all rights reserved. (2000)

Troubleshooting

Problem	Probable Cause	Action
The load will not turn on.	An open sensor.	Repair or replace.
	The load circuit is open.	Check the fuses, circuit breakers, load and wiring.
	The ac input is not connected or is connected improperly.	Compare the ac input connections with the appropriate wiring diagram.
The load will not turn off.	The thermocouple polarity is reversed.	Compare the input connections with the appropriate wiring diagram.
	A faulty unit.	Remove power to the controller and the controller from the system. Apply power to the system with the controller removed. If the load turns off, return the controller to the factory. If the load remains on, there are other problems in the system that must be resolved. Consult the factory.