



**JETPoE**

**JetNet 6710G / 6810G Series**

**Industrial 8-Port PoE plus 2 Gigabit-TX  
Managed Ethernet Switch**

**Quick Installation Guide**

V1.0

[www.korenix.com](http://www.korenix.com)

## 1. Overview

The JetNet 6710G/6810G series are Managed Industrial Power over Ethernet Switches, equipped with eight 10/100 TX ports with 15.4 watts PoE injector and dual 10/100/1000 TX ports for uplink connection.

By software configuration or by LLDP auto detection, the eight 10/100 TX PoE injector ports of JetNet 6710G series can deliver 15.4W by IEEE 802.3af or 30W by the latest High Power PoE IEEE 802.3at standard for supporting High Power Requiring Devices (PD).

Besides, the eight IEEE 802.3af PoE injector ports of JetNet 6810G series are designed with the Korenix patented Booster PoE technology, which allows the switches to adopt 24~57VDC input and deliver 15.4W per port at 48V for applications where DC 48V power supply is not available.

The 2 Gigabit Ethernet ports can provide high speed uplink connectivity to higher level backbone switches with Korenix MSR™ network redundancy technology, which can recover any failure in less than 5milliseconds. To work under vibration and shock environments, the switches are designed with industrial D-coded M12 connectors or rugged RJ45 connectors to ensure exceptional solid Ethernet and PoE connections.

### 1-1 Packing List Checking

The JetNet 6000G series is shipped with the following items. If any of these items is missing or damaged, please contact your customer service representative for assistance.

	JetNet 6710G-M12	JetNet 6710G-RJ	JetNet 6810G-M12	JetNet 6810G-M12
JetNet 6710G Managed High Power IEEE 802.3at PoE Switch (M12 / Rugged RJ)	1	1		
JetNet 6810 Managed Booster PoE Switch ( M12 / Rugged RJ)			1	1
M12 on DB9 Shielded Console Cable	1	1	1	1
Rugged M12 D-coded 4-pole Field Assemble able Connector	8		8	
Rugged M12 A-coded 8-pole Field Assemble able Connector	2		2	
Rugged RJ45 Field Assemble able Connector		10		10
2 Wall-Mount kits & 8 Screws	1	1	1	1
Quick Installation Guide	1	1	1	1
Documentation and Software CD-ROM	1	1	1	1

## 1-2 Introduction to the Manual

The following manuals are included as PDF files on the CD-ROM:

- ▶ Quick Installation Guide: includes information on installing all versions of JetNet 6710G / 6810G series PoE Switch
- ▶ User manual – Configuration: applied to the managed versions of JetNet 6710G/ 6810G series PoE Switch

## 2. Appearances

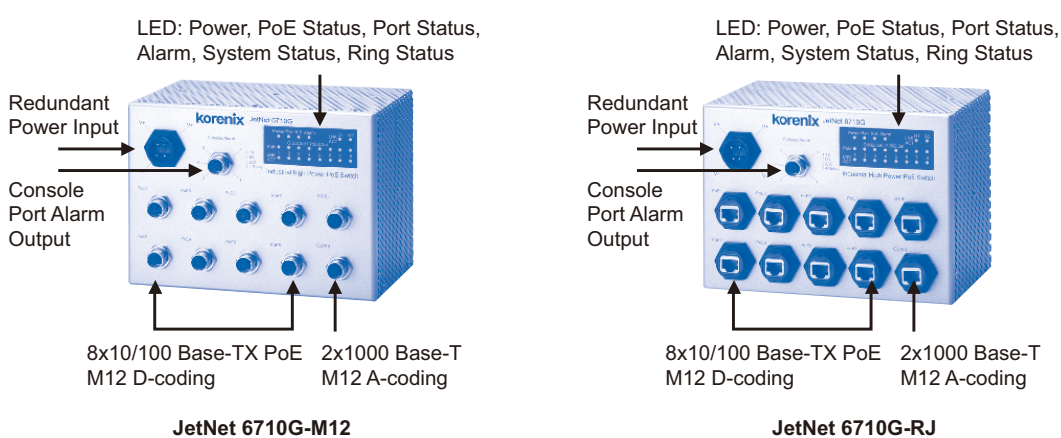

## 3. Hardware Installation

### 3-1 Powering of the system

The Power input port is located at the top of the front panel and supports redundant input function via a proprietary assembly capable IP-67 connector (CDG-L207SA) included in the shipment. If you cannot find this power connector, please contact your local distributor. For the available input power range and recommended cable size, please refer to the below table.

	Power Input (DC Voltage)			Input Conductor	Cable Size
	Minimum	Maximum	Recommended		
<b>JetNet 6710G-M12</b>	48	60	48	V1, V2	AWG 14 / 2.0
<b>JetNet 6710G-RJ</b>	48	60	48	V1, V2	AWG 14 / 2.0
<b>JetNet 6810G-M12</b>	22	60	24	V1, V2 bind together	AWG 14 / 2.0
<b>JetNet 6810G-RJ</b>	22	60	24	V1, V2 bind together	AWG 14 / 2.0

The JetNet 6810G only supports single power input that binds V1 and V2 together to obtain higher current for the booster.

Use the UL listed Switching power supply to power the JetNet Switch. For the power wiring method, please refer to the figures 3.1-1 and 3.1-2. For system safety and the anti-immunity ability, the chassis ground screw should be well grounded to the earth ground.

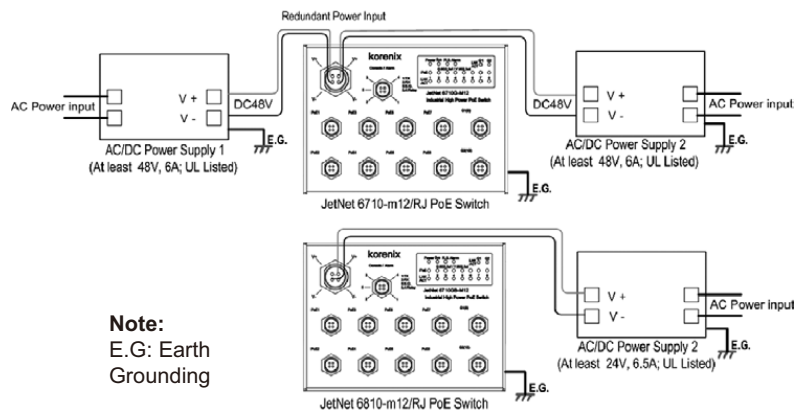

**Note:**  
E.G: Earth  
Grounding

Figure 3.1-1. Power Supply wiring architecture

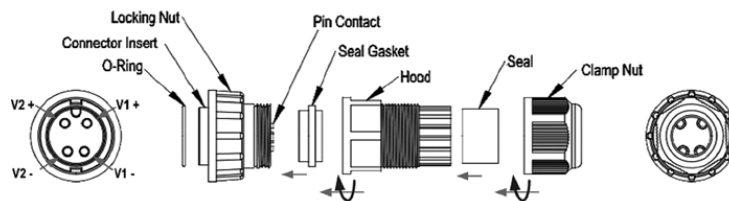

Figure 3.1-2 Power connector assembly diagram

### 3.2 RS-232 console and Relay Output Connection

The RS-232 console and the alarm relay are connected via the assembly type of 5-pole M12 A-coding connector included in the supplied package of JetNet switch. The following figure 3-2-1 is the disassembly diagram of M12 A-coding connector.

In the M12 connector packing, the parts 1, 2, 3 are already assembled.

Follow the steps for soldering and assembling the cable and connector together:

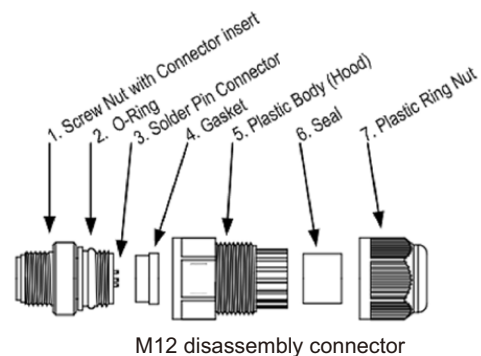
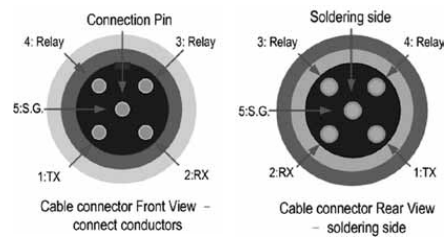

Figure 3.2-1 Field Assemble

**Step -1:** Slide component 4, 5, 6 and then 7 over the console cable. Keep them loose. Do not tighten them yet. 2 cable glands are provided for cable diameter from 3.5 to 5.8 mm. Choose the one that best fits the cable.



**Step-2:** Solder the conductors with the copper wires according to the pin assignment. The soldering side view of the pin is shown as below:



Console port pin assignment

**Step-3:** Fasten the components 4, 5, 6 and 7 in sequence. Be sure the gasket is on the right position. See the below M12 assembly diagram:



1. Assembly part 1 and 4, ensure the solder pins are protected by part 4-gasket, then locking part 1 and 5.



2. Insert part 6-seal into part 5.



3. Locking part 5 and 7.



4. Finalized

### 3.3 Assembly of Ethernet Patch Cables

You can connect terminal devices and other segments via twisted pair cables. Ports which are not assigned should be closed with the covering caps contained in the package list of delivery to guarantee the connector is clear without rust.



Never install or work on/with the equipment or the cabling during the period of its lightning activity.

### 3.3.1 Assembly of M12 Ethernet Connector

For Fast Ethernet M12 D-Code to M12 D-Code connection, you can use either version below:

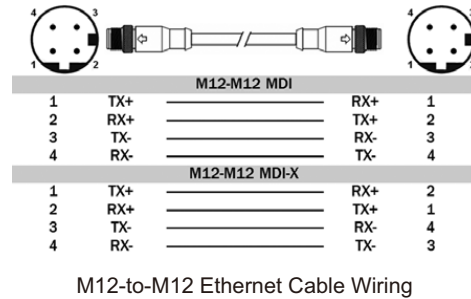

For Fast Ethernet M12 D-Code to RJ45 connection, the pin assignment of the patch cable is shown below:

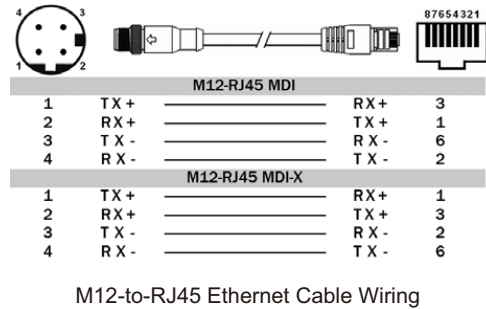

For Gigabit Ethernet M12 A-Code to RJ45 connection, the pin assignment of the patch cable is shown below:



### 3.3.2. Assembly of Rugged RJ45 Connector

The RJ version provides robust connection by the field assembly capable rugged RJ45 connector. Each component of the connector is shown below:

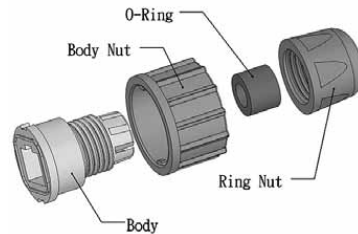

3.3.2-1 Rugged RJ45 Connector Components



Follow the steps to assemble the rugged RJ45 connector:

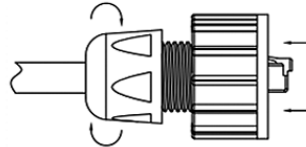
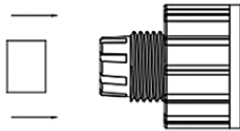
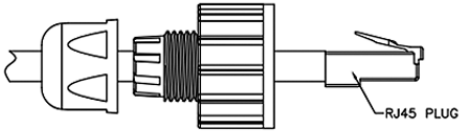
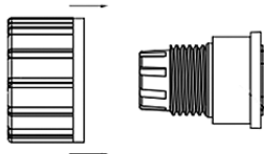
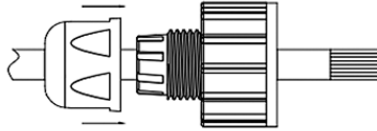
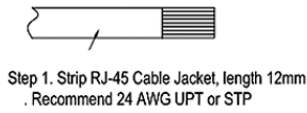

### M12-to-RJ45 Ethernet Cable Wiring

Following picture-19 shows the color code of Cat.-5E UTP/STP cable based on the two standards released by TIA/EIA – 568A and 568B. The 568B wiring is by far, the most common wiring method. You can choose the method that suits your application; but ensure that both ends of the cable use the same standard.

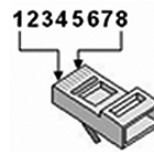
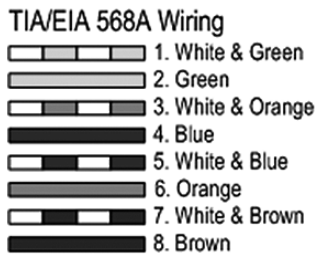

RJ-45 Plug conductor number

RJ45 Cable color code

### 3.4 Wall /Panel Mounting Installation

The JetNet 6710G/6810G series are shipped with 1 set mounting bracket which allows users to install JetNet 6710G/6810G on the panel or wall. Assemble the brackets on the rear side of JetNet 6710G/6810G body, then using a suitable screw install onto wall / panel of cabinet with good heat dissipation.

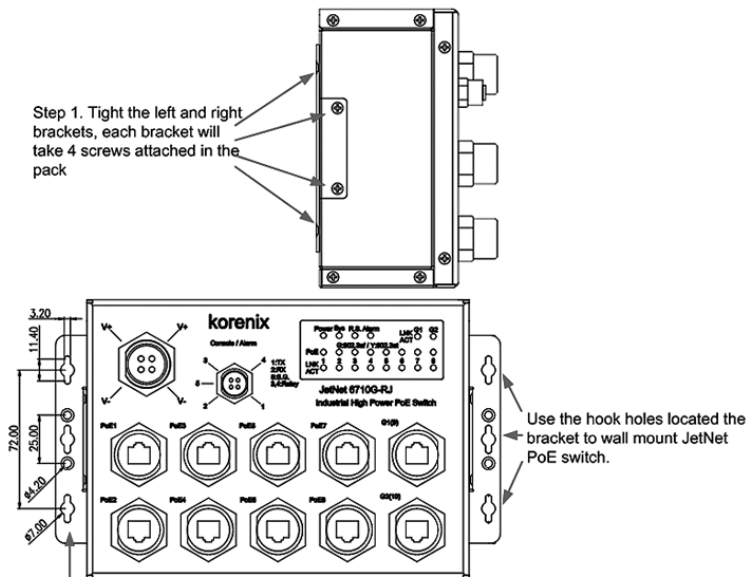

Step 2. The size of screw-nut must between  $\Phi 7.0$  to 3.2mm. Lock screw slightly, move and clamp the bracket then tighten the screws.

## 4. Device Management

JetNet 6710G / 6810G series switches provide both in-band and out-band configuration methods. You can configure the switch via the RS232 console with the attached console cable, or you can remotely manage the switch via network using Telnet/SSH, Web/HTTPS management.

### 4.1 Preparation for console management

Attach the RS-232 DB9 connector to your PC's COM port. Connect the M12 A-code 5-pin connector to the console port of the JetNet 6710G/6810G.

4.1.1 Go to Start -> Program -> Accessories -> Communication -> Hyper Terminal

4.1.2 Give a name to the new console connection to create a new serial communication session.

4.1.3 Choose the COM name, and select the correct serial settings. The serial settings of JetNet 6710G/6810G are as below:

Baud Rate: 9600 / Parity check: None / Data Bit: 8 / Stop Bit: 1



4.1.4 After connected, you can see Switch login request. Type-in the username and password to login. The default username is “admin”, password is “admin” for console interface.

4.1.5 Follow the manual to configure the device features.

## 4.2 Preparation for Web management

Before you attempt to use the embedded web interface to manage switch operation, verify that your JetNet switch is properly installed on your network and that every PC on this network can access the switch via the web browser.

4.2.1 Launch the web browser (Internet Explorer or Mozilla Firefox) on the PC.

4.2.2 Type `http:// 6710G_IP_Address` or `6810G_IP_Address` (The default IP address is 192.168.10.1.), then press Enter.

4.2.3 The login screen will appear next. Type-in the user name and the password. The default user name and password is admin/admin.

4.2.4 Click OK, and then the welcome page of the web-based management interface will appear.

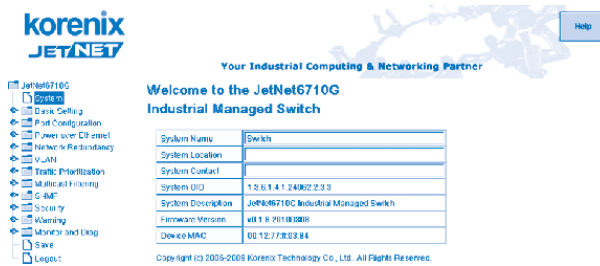

At the left column of the Web management interface are listed the available software features; by pressing the ring column you can also view the detailed configuration interface.

For more detailed management features please refer to the software’s users’ manual. The software user manual can be downloaded from Korenix Website as below:

<http://www.korenix.com/downloads.htm>



**korenix**

Tel:+886-2-89111000

Fax:+886-2-29123328

Business service:sales@korenix.com

Customer service:koreCARE@korenix.com

CPQ000N6710000