

LonWorks[®] Option Board for VS Series Drives

User Manual

New Information
August 2004



VS IntelliPass Bypass



VS Open

August 2004

Important Notice – Please Read

The product discussed in this literature is subject to terms and conditions outlined in Johnson Controls selling policies. The sole source governing the rights and remedies of any purchaser of this equipment is the relevant Johnson Controls selling policy.

NO WARRANTIES, EXPRESS OR IMPLIED, INCLUDING WARRANTIES OF FITNESS FOR A PARTICULAR PURPOSE OR MERCHANTABILITY, OR WARRANTIES ARISING FROM COURSE OF DEALING OR USAGE OF TRADE, ARE MADE REGARDING THE INFORMATION, RECOMMENDATIONS AND DESCRIPTIONS CONTAINED HEREIN. In no event will Johnson Controls or Eaton Electrical Inc. be responsible to the purchaser or user in contract, in tort (including negligence), strict liability or otherwise for any special, indirect, incidental or consequential damage or loss whatsoever, including but not limited to damage or loss of use of equipment, plant or power system, cost of capital, loss of power, additional expenses in the use of existing power facilities, or claims against the purchaser or user by its customers resulting from the use of the information, recommendations and descriptions contained herein.

The information contained in this manual is subject to change without notice.

Cover Photo: Johnson Controls VS Series Drives.

Table of Contents

LIST OF FIGURES	iii
LIST OF TABLES	iii
SAFETY	iv
Definitions and Symbols	iv
Hazardous High Voltage	iv
Warnings and Cautions	v
CHAPTER 1 — GENERAL	1-1
CHAPTER 2 — LONWORKS OPTION BOARD TECHNICAL DATA	2-1
General Specifications	2-1
Physical Media and Wiring	2-2
Profiles	2-3
Adjustable Frequency Drive Profile	2-3
CHAPTER 3 — LONWORKS FIELDBUS BOARD LAYOUT AND CONNECTIONS	3-1
LonWorks OPTC4 Option Board	3-1
Grounding of Bus Cable Shield in OPTC4	3-1
Bus Termination Resistors	3-3
LED Indications	3-4
CHAPTER 4 — INSTALLATION OF LONWORKS OPTION BOARD	4-1
Board Information Sticker	4-3
CHAPTER 5 — START-UP	5-1
Fieldbus Board Parameters	5-1
Start-Up Test	5-2
CHAPTER 6 — LONWORKS INTERFACE	6-1
Features of the LonWorks Interface	6-1
General Information	6-1
Input Network Variables	6-3
Output Network Variables	6-6
Network Configuration Variables	6-8
Process Data	6-10
CHAPTER 7 — FAULT TRACKING	7-1
CHAPTER A — PROCESS DATA	A-1
Process Data OUT	A-1
Process Data IN	A-1

August 2004

List of Figures

Figure 2-1: Doubly Terminated Bus Topology	2-2
Figure 2-2: Singly Terminated Bus Topology	2-2
Figure 2-3: Star Topology	2-2
Figure 2-4: Loop Topology	2-2
Figure 3-1: LonWorks Option Board OPTC4	3-1
Figure 3-2: Using Jumper X5 to Set the Bus Termination	3-3
Figure 3-3: LED Indications on the LonWorks Board	3-4
Figure 4-1: Information Sticker	4-3
Figure 5-1: Changing the Parameter Value	5-1
Figure 6-1: The Node Object Diagram	6-1
Figure 6-2: The Adjustable Frequency Motor Drive Object Diagram	6-2
Figure 6-3: Control of Drive through LonWorks	6-10

List of Tables

Table 2-1: LonWorks Technical Data	2-1
Table 2-2: Line Length for Different Transmission Speeds	2-3
Table 3-1: OPTC4 Bus Connector Signals	3-1
Table 3-2: Grounding the Bus Cable Shield	3-2
Table 3-3: Neuron Status (H3) GREEN	3-4
Table 3-4: Board Status LED (H2) YELLOW	3-4
Table 3-5: Bus Status LED (H1) GREEN	3-5
Table 4-1: Installation of LonWorks Option Board	4-1
Table 5-1: LonWorks Parameters	5-1
Table 6-1: Input Network Variables	6-3
Table 6-2: Speed Setpoint Variable Parameters	6-3
Table 6-3: Fault Reset Variable Parameters	6-4
Table 6-4: Digital In Variable Parameters	6-4
Table 6-5: Grouping of ID Numbers	6-5
Table 6-6: Output Network Variables	6-6
Table 6-7: Object Status Variable Parameters	6-6
Table 6-8: Status Word Bit Descriptions	6-7
Table 6-9: Digital Out Variable Parameters	6-7
Table 6-10: Network Configuration Variables	6-8
Table 7-1: LonWorks Option Board Faults	7-1
Table 7-2: Drive Response to Faults	7-1
Table A-1: Process Data OUT Values	A-1
Table A-2: All Applications	A-1

Safety

Definitions and Symbols

 WARNING

This symbol indicates high voltage. It calls your attention to items or operations that could be dangerous to you and other persons operating this equipment. Read the message and follow the instructions carefully.

 WARNING

This symbol is the "Safety Alert Symbol." It occurs with either of two signal words: CAUTION or WARNING, as described below.

 WARNING

Indicates a potentially hazardous situation which, if not avoided, can result in serious injury or death.

 CAUTION

Indicates a potentially hazardous situation which, if not avoided, can result in minor to moderate injury, or serious damage to the product. The situation described in the CAUTION may, if not avoided, lead to serious results. Important safety measures are described in CAUTION (as well as WARNING).

Hazardous High Voltage

 WARNING

Motor control equipment and electronic controllers are connected to hazardous line voltages. When servicing drives and electronic controllers, there may be exposed components with housings or protrusions at or above line potential. Extreme care should be taken to protect against shock.

Stand on an insulating pad and make it a habit to use only one hand when checking components. Always work with another person in case an emergency occurs. Disconnect power before checking controllers or performing maintenance. Be sure equipment is properly grounded. Wear safety glasses whenever working on electronic controllers or rotating machinery.

August 2004

Warnings and Cautions

 **WARNING**

Internal components and circuit boards are at high potential when the drive is connected to the power source. This voltage is extremely dangerous and may cause death or severe injury if you come into contact with it.

 **CAUTION**

Make sure that the drive is **switched OFF** before an option or fieldbus board is changed or added.

August 2004

Chapter 1 — General

Johnson Controls VS Series Drives powered by Cutler-Hammer® technology from Eaton's electrical business can be connected to the LonWorks® network using a fieldbus board. The drive can then be controlled, monitored and programmed from the host system.

The LonWorks board shall be installed in slot E on the control board of the drive.

LonWorks technology has been developed by Echelon Corporation. LONWORKS network is used in applications like industry and building automation, controlling household electronics, medical instrumentation and many others. The target of the LONWORKS network is to provide a common vendor independent communication network for intelligent devices.

In a LONWORKS network, no central control or master-slave architecture is needed. Nodes on a network communicate with each other using LonTalk® protocol. Interoperable nodes use Standard Network Variable Types (SNVT) for communicating over the network. The definition of an SNVT includes units, a range, and an increment. The Johnson Controls OPTC4 option board uses only Standard Network Variable Types for the data types.

All network variables are either input (data is coming from the network to the device) or output (data is sent to the network by the device) network variables. When network variables on different nodes on the network have been bound together by an installation tool, passing of data is automatic between the right nodes. Only the same type of network variables can be bound together, so it is very important to have compatible interfaces.



WARNING

Internal components and circuit boards are at high potential when the drive is connected to the power source. This voltage is extremely dangerous and may cause death or severe injury if you come into contact with it.

August 2004

Chapter 2 — LonWorks Option Board Technical Data

General Specifications

Table 2-1: LonWorks Technical Data

Description	Specification
LonWorks Connections	
Interface	Pluggable Connector (5 mm)
Communications	
Channel type	TP/FT-10
Transfer cable	Twisted pair
Baud rate	78 Kbit/s
Environment	
Ambient operating temperature	14° – 122°F (-10° – 50°C)
Storing temperature	-40° – 158°F (-40° – 70°C)
Humidity	<95%, no condensation allowed
Altitude	Max. 1000m
Vibration	0.5 G at 9 – 200 Hz
Safety	
Standards	Fulfils EN 50178 standard

Physical Media and Wiring

LonWorks networks can be implemented on many different physical media. The OPTC4 option board is equipped with an FTT-10A transceiver supporting the Free Topology transformer coupled network, which allows the network wire to be connected as bus, star, loop or combination of these. This media reaches a communication speed of 78 kBits/s. The FTT-10A transceiver is compatible with Echelon's LPT-10 Link Power Transceiver, and these transceivers can communicate with each other on a single twisted pair cable.

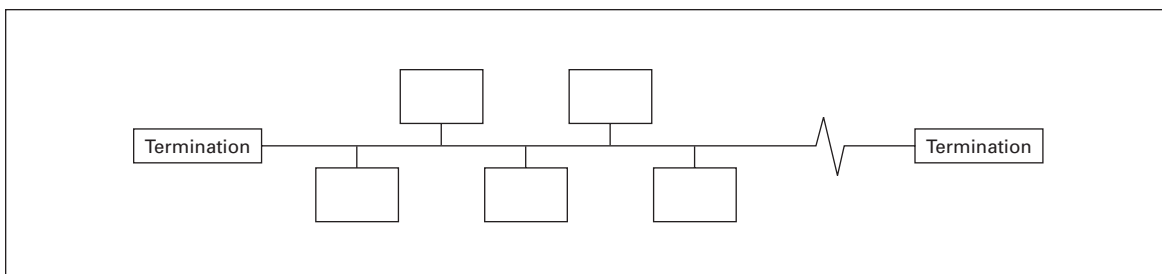

Figure 2-1: Doubly Terminated Bus Topology

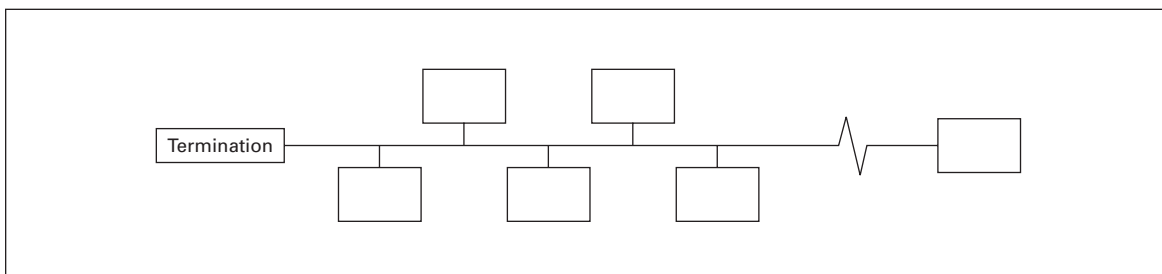

Figure 2-2: Singly Terminated Bus Topology

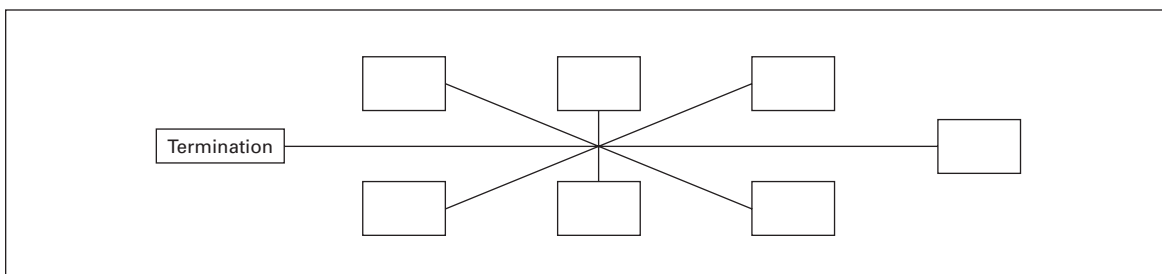

Figure 2-3: Star Topology

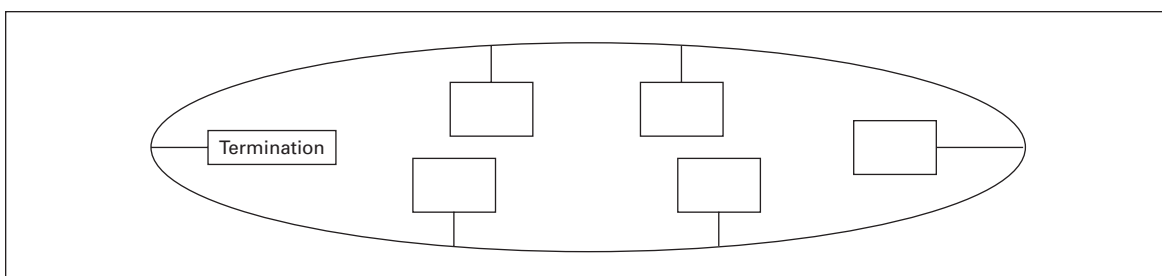

Figure 2-4: Loop Topology

August 2004

Up to 64 FTT-10 transceiver nodes are allowed per network segment, the individual segments can be connected together by a router. See **Table 2-2** for recommended cable types and cable lengths for FTT-10. Even if unshielded cable types are recommended to be used with this type of transceiver, it is still *highly recommended to use only shielded cables with adjustable frequency drives*. Attention should be paid to proper grounding of the shield to ensure bus operation. Grounding of the shield should be done at both ends of the cable.

Table 2-2: Line Length for Different Transmission Speeds

Cable Type	Maximum Doubly Terminated Bus Length	Maximum Free Topology Wire Length	Maximum Node-to-Node Distance
Belden 85102 (unshielded)	8,860 Ft. (2700m)	1,640 Ft. (500m)	1,640 Ft. (500m)
Belden 8471 LONAK 2x1.3 (unshielded)	8,860 Ft. (2700m)	1,640 Ft. (500m)	1,315 Ft. (400m)
Level IV, 22 AWG LONAK 2x2x0.65 (unshielded)	4,595 Ft. (1400m)	1,640 Ft. (500m)	1,315 Ft. (400m)
JY (St) Y 2x2x0.8 mm LONAK 2x2x0.8 (shielded)	2,955 Ft. (900m)	1,640 Ft. (500m)	1,050 Ft. (320m)

Profiles

LonMark Functional Profiles describe in detail the application layer interface, including the network variables, configuration properties, and default and power-up behaviors required on LonMark devices for specific, commonly used control functions.

Adjustable Frequency Drive Profile

Leading manufacturers of drive technology have jointly defined the LonMark profile. The profile specifies how the drives are to be parameterized and how the setpoints and actual values are to be transmitted. This enables drives from different vendors to be exchanged. The profile contains necessary specifications for speed control and positioning. It specifies the basic drive functions while leaving sufficient freedom for application-specific expansions and further developments.

August 2004

Chapter 3 — LonWorks Fieldbus Board Layout and Connections

The Johnson Controls LonWorks Fieldbus Board is connected to the fieldbus through 3-pin pluggable bus connector. The communication with the control board takes place through the standard Interface Board Connector.

LonWorks OPTC4 Option Board

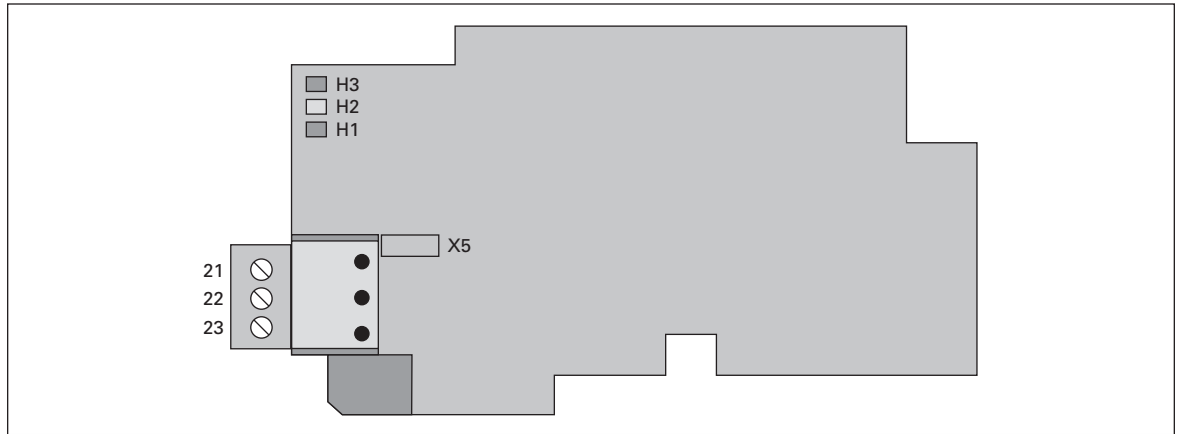

Figure 3-1: LonWorks Option Board OPTC4

Table 3-1: OPTC4 Bus Connector Signals

Signal	Connector	Description
A1	21	Data
A2	22	Data
0Shield	23	Shield

Grounding of Bus Cable Shield in OPTC4

The bus cable shield can be grounded to the frame of the drive through an RC filter located on the OPTC4 board.

Note: Normally, the option board has already been installed in slot E of the control board. It is not necessary to detach the whole board for the grounding of the bus cable shield. Just detach the terminal block.

Grounding the Bus Cable Shield Directly to the Drive Frame Using the RC-Filter

Table 3-2: Grounding the Bus Cable Shield

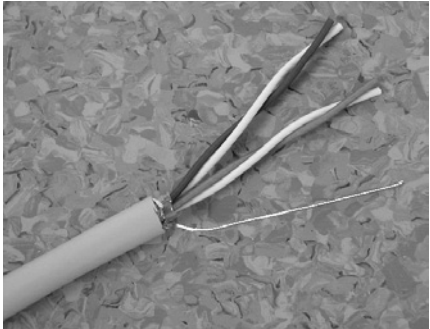
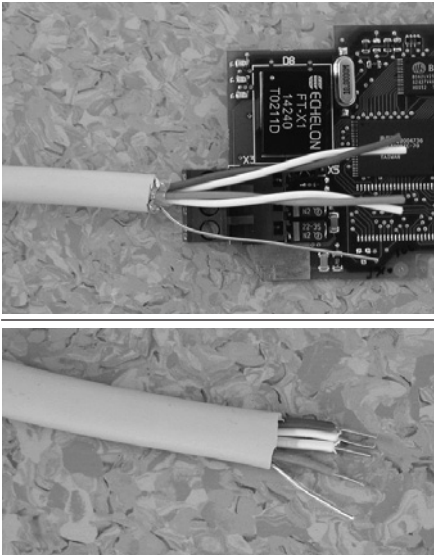
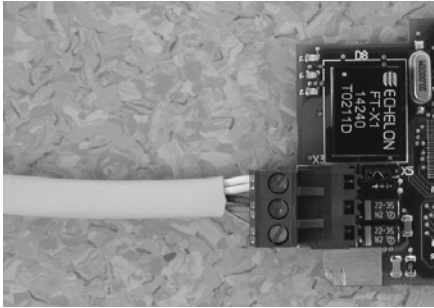
Step	Procedure
A	Strip about 2 Inches (50 mm) of the cable as shown in the picture. 
B	Leave no more than 1/4 Inch (7 mm) of the data cable outside the terminal block (top) and strip the data cables at about 3/16 Inch (5 mm) to fit in the terminals (bottom). 
C	Insert the data cables and the shield in their respective terminals. See Table 3-1 . 

August 2004

Table 3-2. Grounding the Bus Cable Shield, continued

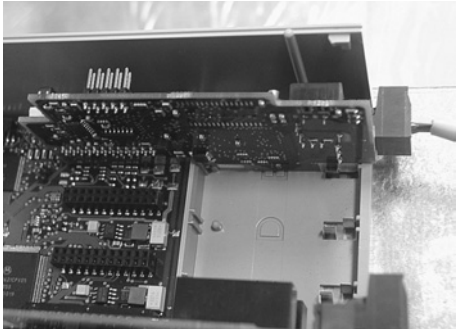
Step	Procedure
D	<p>If the LonWorks board was detached from the control unit, place it into slot E of the control board (see Page 4-2). Otherwise attach the terminal block. Fix the cable on the frame with the clamp.</p> 

Bus Termination Resistors

To assure a proper data transmission, termination of the network segments is required. Depending on the type of network, either one or two terminations are necessary. Free topology network segment requires only one termination whereas a doubly terminated bus topology requires two.

The jumper X5 on the LonWorks board must be set accordingly. Use 94-ohm termination resistance when only one termination is needed and 47-ohm for two terminations.

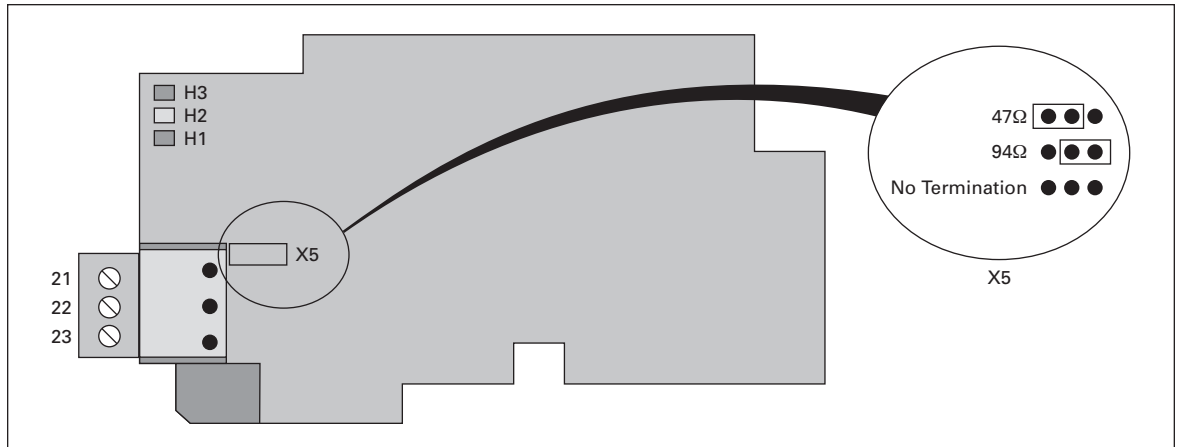

Figure 3-2: Using Jumper X5 to Set the Bus Termination

LED Indications

The three LED indications next to the connector show the present statuses of the Neuron (green H3), the LonWorks board (yellow H2) and the Fieldbus Module (green H1). From the user's viewpoint, the first two are the most significant.

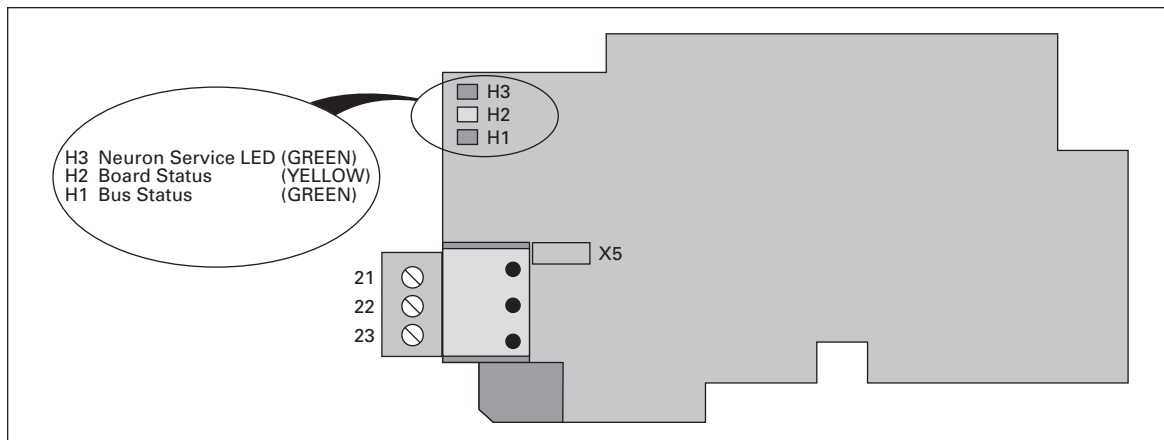

Figure 3-3: LED Indications on the LonWorks Board

Table 3-3: Neuron Status (H3) GREEN

LED Is:	Meaning	State Code
OFF	Configured	4
ON	Applicationless and Unconfigured	3
Flashing	Unconfigured	2

Table 3-4: Board Status LED (H2) YELLOW

LED Is:	Meaning
OFF	Option board not activated
ON	Option board in initialization state waiting for activation command from the drive
Blinking fast (once/1S)	Option board is activated and in RUN state
	Option board is ready for external communication
Blinking slow (once/5S)	Option board is activated and in FAULT state
	Internal fault on option board

August 2004

Table 3-5: Bus Status LED (H1) GREEN

LED Is:	Meaning
OFF	Fieldbus module is waiting for parameters from the drive
	No external communication
ON	Fieldbus module is activated
	Parameters received and module activated
	Module is waiting for messages from the bus
Blinking very fast for 5S (once/0.2S)	Fieldbus module has received a wink request
Blinking fast (once/1S)	Module is activated and receiving messages from the bus
Blinking slow (once/5S)	Module is in FAULT state
	No messages from Net within the watchdog time
	Bus broken, cable loose

August 2004

Chapter 4 — Installation of LonWorks Option Board

⚠ CAUTION

Make sure that the drive is **switched OFF** before an option or fieldbus board is changed or added.

Table 4-1: Installation of LonWorks Option Board





Step	Procedure
A	VS Series Adjustable Frequency Drive. 
B	Remove the cable cover. 
C	Open the cover of the control unit. 

Table 4-1. Installation of LonWorks Option Board, continued

Step	Procedure
<p>D</p>	<p>Install LonWorks option board in slot E on the control board of the drive. Make sure that the grounding plate (see below) fits tightly in the clamp.</p>  
<p>E</p>	<p>Make a sufficiently wide opening for your cable by cutting the grid as wide as necessary.</p> 
<p>F</p>	<p>Close the cover of the control unit and the cable cover.</p> 

August 2004

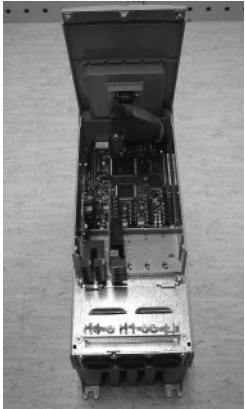
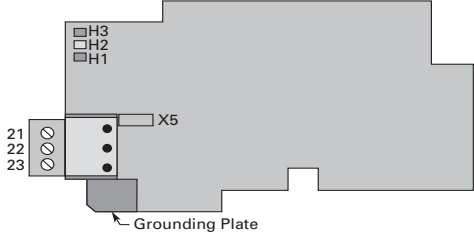
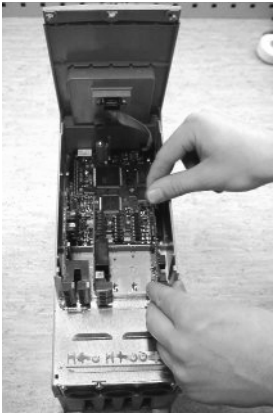
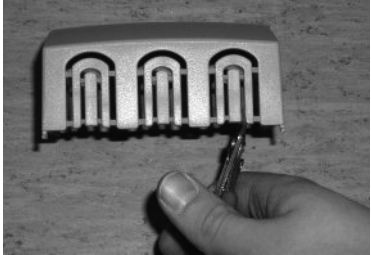
Board Information Sticker

The LonWorks option board package delivered by the factory includes a sticker (shown below). Please mark the board type (1), the slot into which the board is mounted (2) and the mounting date (3) on the sticker. Finally, attach the sticker on your drive.

		Drive modified:			
<input type="checkbox"/>	Option board:	OPT.....	Date:.....		
	in slot:	A B C D E			
<input type="checkbox"/>	IP54 upgrade/ Collar		Date:.....		
<input type="checkbox"/>	EMC level modified:	H → T / T → H	Date:.....		

Figure 4-1: Information Sticker

August 2004

Chapter 5 — Start-Up

First read the Start-Up chapter in your *VS Series Drive User Manual*.

Fieldbus Board Parameters

The LonWorks board is commissioned with the control keypad by giving values to appropriate parameters in menu M6 (for locating the expander board menu, see the *VS Series Drive User Manual*).

Expander Board Menu (M6)

The Expander board menu makes it possible for the user 1) to see what expander boards are connected to the control board and 2) to reach and edit the parameters associated with the expander board.

Enter the following menu level (G#) with the menu button right. At this level, you can browse through slots A to E with the browser buttons to see what expander boards are connected. On the lowermost line of the display, you also see the number of parameter groups associated with the board.

If you still press the menu button right once, you will reach the parameter group level including one parameter (Service pin).

LonWorks Parameters

To commission the LonWorks board, enter the parameter G6.5.1.1 from the Parameters group (G6.5.1). Give the desired value to the LonWorks parameter.

Table 5-1: LonWorks Parameters

#	Name	Default	Range	Description
1	Service Pin	0	0 – 1	Broadcasts a service pin message to the network.

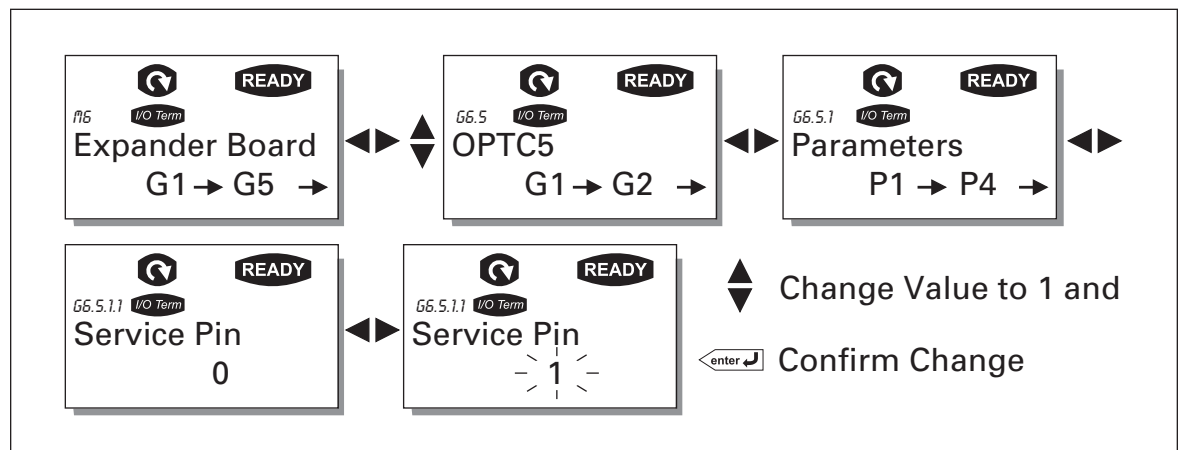

Figure 5-1: Changing the Parameter Value

Start-Up Test

Drive Application

Choose Fieldbus (Bus/Comm) for the active control place (see the *VS Series Drive User Manual*).

Master Software

1. Write 100.0 1 to nviDrvSpeedStpt.
2. Drive status is RUN and output frequency is $1.00 * \text{nviDrvSpeedScale}$
3. Write 0.0 0 to nviDrvSpeedStpt
4. Drive status is STOP.

If nvoDrvStats bit 3 = 1, Status of drive is FAULT.

August 2004

Chapter 6 — LonWorks Interface

Features of the LonWorks Interface

- Direct control of VS Series drive (e.g. Run, Stop, Direction, Speed reference, Fault reset)
- Full access to all VS Series drive parameters
- Monitor VS Series drive status (e.g. Output frequency, Output current, Fault code)

General Information

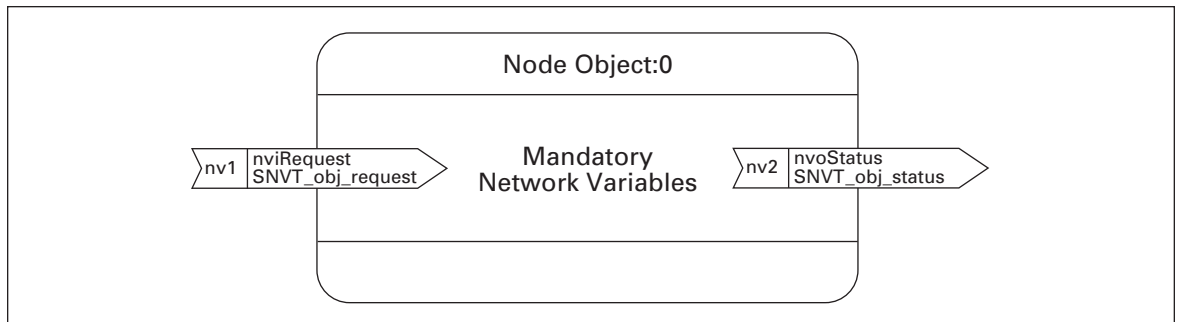

Figure 6-1: The Node Object Diagram

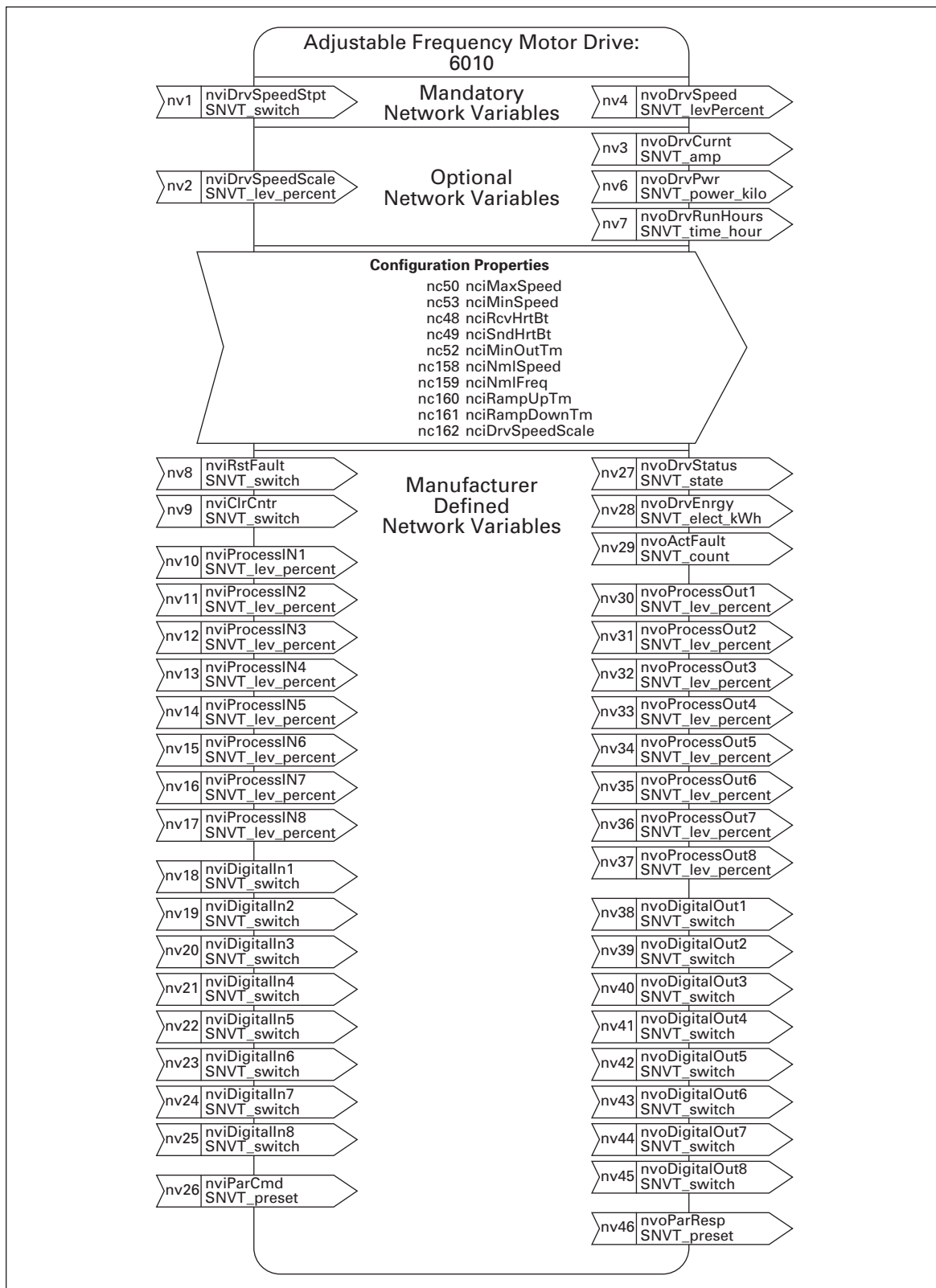

Figure 6-2: The Adjustable Frequency Motor Drive Object Diagram

August 2004

Input Network Variables

Table 6-1: Input Network Variables

Function	Variable Name	SNVT Type	Min. Value	Max. Value
Node Object request	nviRequest	SNVT_obj_request	—	—
Driver speed setpoint	nviDrvSpeedStpt	SNVT_switch	n/a	n/a
Driver setpoint speed scaling	nviDrvSpeedScale	SNVT_lev_percent	-163.840%	163.830%
Reset fault	nviRstFault	SNVT_switch	n/a	n/a
Clear kWh trip or Drive total running hours trip counters	nviClrCntr	SNVT_switch	1	2
Process In Data	nviProcessIn1-8	SNVT_lev_percent	0	65535
Digital Inputs	nviDigitalIn1-8	SNVT_switch	0	4
Parameter Set	nviParCmd	SNVT_preset	n/a	n/a

nviRequest

This input network variable provides the mechanism to request a particular mode for the Node object or the Adjustable Frequency Motor Drive object within a node. Supported requests are RQ_NORMAL, RQ_UPDATE_STATUS, RQ_CLEAR_STATUS, RQ_REPORT_MASK, RQ_DISABLED, RQ_ENABLE and RQ_CLEAR_ALARM.

nviDrvSpeedStpt

This input network variable provides control and a low resolution speed setpoint.

Table 6-2: Speed Setpoint Variable Parameters

State	Value	Command
0	NA	Stop
1	0	0%
1	1 to 200	0.5 to 100%
1	201 to 255	100.0%
0xFF	NA	Auto

nviDrvSpeedScale

This input network variable provides scaling for nviDrvSpeedStpt. Negative values indicate a motor direction in reverse. For example, if the nviDrvSpeedStpt value is 50% and nviDrvSpeedScale -150%, then the actual speed setpoint is -75%, or 0.75 times the nominal speed in reverse direction. The valid range is -163,840% to 163,830. The value 0x7FFF (+163,835%) will be handled as an invalid value. Default value is determined by nciDrvSpeedScale. This value will be adopted at power-up and in case of not receiving an update within the specified Receive Heartbeat time.

nviRstFault

This input network variable provides a fault reset. Setting value 1 for State and a non-zero value for Value will reset an active fault. Default value is 0; 0.

Table 6-3: Fault Reset Variable Parameters

State	Value	Command
0	any	no action (0; 0)
1	0	no action (0; 1)
1	> 0	reset fault (200; 0)
-1 (0xFF)	any	invalid (no action)

nviClrCntr

This input network variable provides a mechanism to clear the kWh trip counter or the Drive total running hours trip counter.

- 1 MWh trip counter
- 2 Operation day trip counter

nviProcessIn1-8

These input network variables are sent directly to the application (see more detailed explanation in **Figure 6-3 on Page 6-10**). The valid range is 0 to 65535 (-163,840 to 163,835).

nviDigitalIn1-8

These input network variables are sent directly to the application (see more detailed explanation in **Figure 6-3 on Page 6-10**). Default value is 0; 0.

Table 6-4: Digital In Variable Parameters

State	Value	Command
0	any	off (0; 0)
1	0	off (0; 1)
1	> 0	on (200; 1)
-1 (0xFF)	any	invalid (no action)

August 2004

nviParCmd

This input network variable is used to read and write the parameters. The parameter addresses are determined in the application. Every parameter and actual value has been given an ID number in the application. The ID numbering of the parameter as well as the parameter ranges and steps can be found in the application manual in question. The parameter value must be given without decimals. Find the ID numbers of each parameter/actual value in the application manual. The ID numbers are grouped as follows:

Table 6-5: Grouping of ID Numbers

Parameter ID	Group	Description
0	Not used	
1 – 98	Actual Values	
99	Active Fault Code	
100	Not Used	
101 – 899	Parameter	
900 – 999	Reserved	Reserved for LonWorks board internal usage
1000	Not Used	
1001 – 1999	Parameter	

Examples

Data format in examples is:

- learn selector <byte(3) byte(2) byte(1) byte(0)> day hour minute second millisecond
- x = meaningless.

Example 1

Write to parameter number 102 (Max frequency "Basic Application par. ID102") value 4500 (45 Hz).

Write command to nviParSet

- LN_LEARN_CURRENT 102 <x x 11 94> x x x x

If the write command is successful then nvoParOut value is

- LN_LEARN_CURRENT 102 <0 0 11 94> 0 0 0 0

If the write command fails then nvoParOut value is

- LN_NUL 102 <0 0 11 94> 0 0 0 0

Example 2

Read parameter number 112 (Nominal speed of the motor "Basic Application par. ID112") default value 1440 (1440 rpm).

Read command to nviParSet

- LN_RECALL 112 <x x x x> x x x x

If the read command is successful then nvoParOut value is

- LN_RECALL 112 <0 0 5 A0> 0 0 0 0

If the read command fails then nvoParOut value is

- LN_LN_NUL 112 <0 0 0 0> 0 0 0 0

Output Network Variables

Table 6-6: Output Network Variables

Function	Variable Name	SNVT Type	Min. Value	Max. Value
Node Object status	nvoStatus	SNVT_obj_status		
Drive speed feedback	nvoDrvSpeed	SNVT_lev_percent	-163.840%	+163.830%
Actual motor current	nvoDrvCurnt	SNVT_amp	0.0A	3276.7A
Actual drive power	nvoDrvPwr	SNVT_power_kilo	0.0 kW	6553.5 kW
Drive total running hours	nvoDrvRunHours	SNVT_time_hour	0 h	65535
Status word	nvoDrvStatus	SNVT_state	n/a	n/a
kWh trip counter	nvoDrvEnrgy	SNVT_elect_kwh	0 kWh	65535 kWh
Active fault code	nvoActFault	SNVT_count	0	41
Process Out	nvoProcessOut1-8	SNVT_lev_percent	0	65535
Digital Out	nvoDigitalOut1-8	SNVT_switch	0	4
Parameter Out	nvoParResp	SNVT_preset	—	—

NvoStatus

This output network variable reports the status for Node object or Adjustable Frequency Motor Drive object.

Table 6-7: Object Status Variable Parameters

Field	Description
object_id	ID of object within node
invalid_id	1 means requested ID is not implemented in this node
invalid_request	1 means request for unimplemented function
disabled	1 means object disabled
electrical_fault	1 means drive is faulted
in_alarm	1 means drive is in alarm
report_mask	1 means status is an event mask

nvoDrvSpeed

This output network variable provides the speed of the drive as a percentage of the nominal speed.

nvoDrvCurnt

This output network variable provides the drive output current in amperes.

nvoDrvPwr

This output network variable provides the drive output power in kW.

August 2004

nvoDrvRunHours

This output network variable provides the drive resettable operation time counter for the motor in running hours. The maximum value for used SNVT is 65535 h. On the drive, the value can go much higher. If the counter exceeds the SNVT's maximum value, the network variable stays at its maximum. In such cases the real value can be seen on the operating keypad.

nvoDrvStatus

This output network variable provides the drive status.

Table 6-8: Status Word Bit Descriptions

Bit	Description	
	Value = 0	Value = 1
0	Not Ready	Ready
1	FC stopped	Running
2	Clockwise	Counterclockwise
3	No fault	Fault active
4	No warning	Warning active
5	Reference ≠ Actual value	Reference = Actual value

nvoDrvEnrgy

This output network variable provides the drive resettable energy consumption counter. The maximum value for used SNVT is 65535 kWh. On the drive the value can go much higher. If the counter exceeds the SNVT's maximum value, the network variable stays at its maximum. In such cases the real value can be seen on the operating keypad.

nvoActFault

This output network variable provides the drive active fault code. If the value is 0, the drive has no fault. See the fault code list in the *VS Series Drive User Manual* for fault identification.

nvoProcessOut1-8

These output network variables are sent directly from the application (see more detailed explanation in **Figure 6-3** on **Page 6-10**). The valid range is 0 to 65535 (-163,840 to 163,835).

nvoDigitalOut1-8

These output network variables are sent directly from the application (see more detailed explanation in **Figure 6-3** on **Page 6-10**).

Table 6-9: Digital Out Variable Parameters

State	Value	Command
0	0	off (0; 0)
1	200 (0xC8)	on (200; 1)
-1 (0xFF)	any	invalid (NULL)

nvoParResp

Explained in chapter **nviParCmd** on **Page 6-5**).

Network Configuration Variables

Table 6-10: Network Configuration Variables

Function	Variable Name	SNVT Type
Maximum motor speed	nciMaxSpeed	SCPTmaxSetpoint
Minimum motor speed	nciMinSpeed	SCPTminSetpoint
Receive heartbeat time	nciRcvHrtBt	SCPTmaxRcvTime
Send heartbeat time	nciSndHrtBt	SCPTmaxSndTime
Minimum output time	nciMinOutTime	SCPTminSndTime
Nominal motor speed in RPM	nciNmISpeed	SCPTnomRPM
Nominal motor frequency	nciNmIFreq	SCPTnomFreq
Minimum ramp up time	nciRampUpTm	SCPTrampUpTm
Minimum ramp down time	nciRampDownTm	SCPTrampDownTm
Default value for nviDrvSpeedScale	nciDrvSpeedScale	SCPTdefScale

nciMaxSpeed

This configuration property is used to define the maximum speed of a motor. The value is entered as a percentage of nominal speed in RPM, as defined by the Nominal Speed (nciNmISpeed) configuration value. The value of the maximum speed must be validated against the value of the minimum speed as follows:

$$-163.840 \leq \text{minimum speed} \leq \text{maximum speed} \leq 163.830$$

nciMinSpeed

This configuration property is used to define the minimum speed of the motor. The value is entered as a percentage of nominal speed in RPM, as defined by the Nominal Speed (nciNmISpeed) configuration value. The value of the minimum speed must be validated against the value of the maximum speed as follows:

$$-163.840 \leq \text{minimum speed} \leq \text{maximum speed} \leq 163.830$$

nciRcvHrtBt

This configuration property is used to control the maximum time that elapses after the last update of the network variables nviDrvSpeedStpt or nviDrvSpeedScale before the VSD object starts to use the default values.

nciSndHrtBt

This configuration property defines the maximum period that expires before the network variables nvoDrvSpeed, nvoDrvCurnt and nvoDrvPwr are automatically updated.

nciMinOutTime

This configuration property defines the minimum period of automatic network variable transmission.

August 2004

nciNmISpeed

This configuration property is used to provide the nominal speed of the motor in RPM. This value is necessary to determine the minimum and maximum speeds for the motor, based on the configuration properties nciMinSpeed, nciMaxSpeed (entered as a percentage of nominal speed).

nciNmIFreq

This configuration property is used to provide the nominal frequency for the motor.

nciRampUpTm

Defines the acceleration time for the VS Series drive. The valid range is 0.0 to 6,553.4 sec (0.1 sec).

nciRampDownTm

Defines the deceleration time for the VS Series drive. The valid range is 0.0 to 6,553.4 sec (0.1 sec).

nciDrvSpeedScale

This configuration property is used as the default value for nviDrvSpeedScale. This value will be adopted at power-up and in case no input variable within the specified Receive Heartbeat time is received.

Process Data

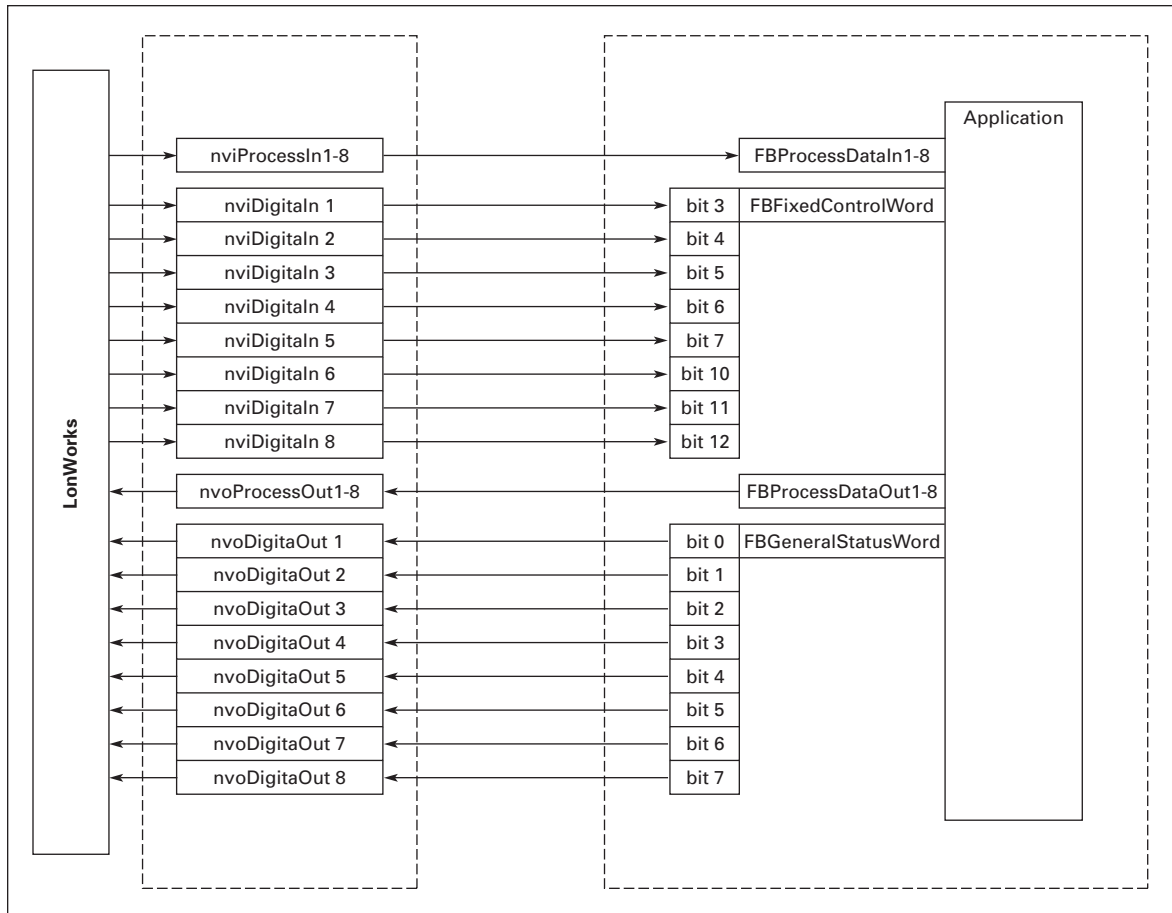

Figure 6-3: Control of Drive through LonWorks

Chapter 7 — Fault Tracking

The table below presents the faults related to the LonWorks option board. For more information, also see *VS Series Drive User Manual*.

The LonWorks option board status LEDs are described in more detail on **Page 3-4**.

Table 7-1: LonWorks Option Board Faults

Fault Code	Fault	Possible Cause	Correcting Measures
37	Device change.	Option board changed.	Reset.
38	Device added.	Option board added.	Reset.
39	Device removed.	Option board removed.	Reset.
40	Device unknown.	Unknown option board.	Contact Johnson Controls.
53	Fieldbus fault.	The received heartbeat time has expired.	Check the installation. If installation is correct contact Johnson Controls.
54	Slot fault.	Defective option board or slot.	Check the board and slot. Contact Johnson Controls.

You can define with parameters how the drive will react to certain faults:

Table 7-2: Drive Response to Faults

Code	Parameter	Min	Max	Unit	Step	Default	ID	Note
P2.7.22	Response to fieldbus fault	0	3		1	0	733	0 = No response 1 = Warning 2 = Fault, stop acc. to 2.4.7 3 = Fault, stop by coasting
P2.7.23	Response to slot fault	0	3		1	0	734	0 = No response 1 = Warning 2 = Fault, stop acc. to 2.4.7 3 = Fault, stop by coasting

August 2004

Appendix A — Process Data

Process Data OUT

The nodes can read the drive's actual values using process data variables.

Standard, Duct Static, Building Static, Pressure Control and Temperature Control Applications use process data as follows:

Table A-1: Process Data OUT Values

Data	Value	Unit	Scale
Process data OUT 1	Output Frequency	Hz	0.01 Hz
Process data OUT 2	Motor Speed	rpm	1 rpm
Process data OUT 3	Motor Current	A	0.1A
Process data OUT 4	Motor Torque	%	0.1%
Process data OUT 5	Motor Power	%	0.1%
Process data OUT 6	Motor Voltage	V	0.1 V
Process data OUT 7	DC link voltage	V	1V
Process data OUT 8	Active Fault Code	—	—

The Standard Control Application has a selector parameter for every Process Data. The monitoring values and drive parameters can be selected using the ID number (see *VS Series Drive User Manual* tables for monitoring values and parameters). Default selections are as in **Table A-1**.

Process Data IN

Process Data is used with All Applications as follows:

Table A-2: All Applications

Data	Value	Unit	Step
Process Data IN1	Reference for PID controller	%	0.01%
Process Data IN2	Actual Value 1 to PID controller	%	0.01%
Process Data IN3	Actual Value 2 to PID controller	%	0.01%
PD4 – PD8	Not Used	—	—

August 2004



Powered by **Eaton's Cutler-Hammer Technology**

Controls Group
507 E. Michigan Street
P.O. Box 423
Milwaukee, WI 53201

© 2004 Johnson Controls
All Rights Reserved
Printed in USA
Publication No. LIT-1201830/CPG
www.johnsoncontrols.com
August 2004