

# Stellaris® Brushed DC Motor Control Module with CAN (MDL-BDC24)

## Ordering Information

Product No.	Description
MDL-BDC24	Stellaris® Brushed DC Motor Control Module with CAN (MDL-BDC24) for Single-Unit Packaging
RDK-BDC24	Stellaris® Brushed DC Motor Control with CAN Reference Design Kit (includes the MDL-BDC24 module)



Figure 1. Brushed DC Motor Control Module

## Contents

<b>General Description</b> .....	<b>1</b>
Overview .....	2
Detailed Features .....	2
<b>Operational Specifications</b> .....	<b>4</b>
Servo-style PWM Input .....	8
Electrical Interface .....	8
Power Supply .....	8
Motor Selection .....	9
Operating Modes .....	9
Default Parameters .....	10
Wiring .....	10
Mechanical Details .....	11
Status LED .....	12
Jumper Settings .....	12
Fault Detection .....	13
Calibration .....	13
CAN Communication .....	13
Coast/Brake Input .....	14
Analog Input .....	15
Encoder Input .....	15
Limit Switch Inputs .....	16
Firmware Update .....	16
<b>Additional Information</b> .....	<b>16</b>

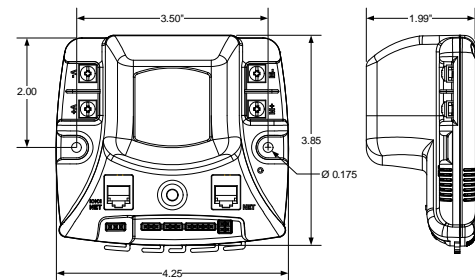

Figure 2. Mechanical Drawing

## General Description

The MDL-BDC24 motor control module is a variable speed control for 12 V and 24 V brushed DC motors at up to 40 A continuous current. The motor control module includes high performance CAN networking as well as a rich set of control options and sensor interfaces, including analog and quadrature encoder interfaces.

The high-frequency pulse width modulator (PWM) enables the DC motor to run smoothly and quietly over a wide speed range. The MDL-BDC24 uses highly optimized software and

# BOARD DATA SHEET

---

a powerful 32-bit Stellaris microcontroller to implement open-loop speed control as well as closed-loop control of speed, position, or motor current.

The MDL-BDC24 is a Stellaris reference design. The Brushed DC Motor Control Reference Design Kit (RDK) contains an MDL-BDC24 motor control module as well as additional hardware and software for evaluating CAN communication. After evaluating the RDK-BDC24, users may choose to either customize the parts of the hardware and software design or use the MDL-BDC24 without modification. For detailed circuit-level information and reference design kit details, see the *Brushed DC Motor Control Reference Design Kit (RDK) User's Manual* (available for download from [www.ti.com/rdk-bdc24](http://www.ti.com/rdk-bdc24)). Use the *MDL-BDC24 Getting Started Guide* if you are using the MDL-BDC24 without modification. Figure 2 shows the MDL-BDC24 motor control module from the top view.

**Figure 2. MDL-BDC24 Motor Control Module**



## Overview

The MDL-BDC24 motor control board provides the following features:

- Controls brushed 12 V and 24 V DC motors up to 40 A continuous
- Controller Area Network (CAN) interface at 1 Mbit/s
- Industry-standard servo (PWM) speed input interface
- RS232 to CAN bridge
- Limit switch, encoder, and analog inputs
- Fully enclosed module includes cooling fan
- Flexible configuration options with simple source file modification
- Easy to customize—full source code and design files available

## Detailed Features

This section describes the MDL-BDC24's features in detail:

- Quiet control of brushed DC motors
  - 15 kHz PWM frequency

# BOARD DATA SHEET

---



- Three options for Speed control
  - Industry-standard R-C servo type (PWM) interface
  - Controller Area Network (CAN) interface
  - RS232 serial interface
- CAN communication
  - Multicast shared serial bus for connecting systems in electromagnetically noisy environments
  - 1M bits/s bit rate
  - CAN protocol version 2.0 A/B
  - Full configurability of module options
  - Real-time monitoring of current, voltage, speed, and other parameters
  - Firmware update
- RS232 serial communication
  - Bridges RS232 port to a CAN network
  - Directly interfaces to a PC serial port or National Instruments cRIO
- Status LED indicates Run, Direction, and Fault conditions
- Motor brake/coast selector
- Limit switch inputs for forward and reverse directions
- Quadrature encoder input (QEI)
  - Index input
  - 5 V supply output to encoder
- Analog input
  - Accepts 10 k $\Omega$  potentiometer or 0-3 V input
- Screw terminals for all power wiring
- Headers (0.1 inch pitch) for all control signals

# BOARD DATA SHEET



**Figure 3. Detailed Drawing of the MDL-BDC24 Motor Control Module**

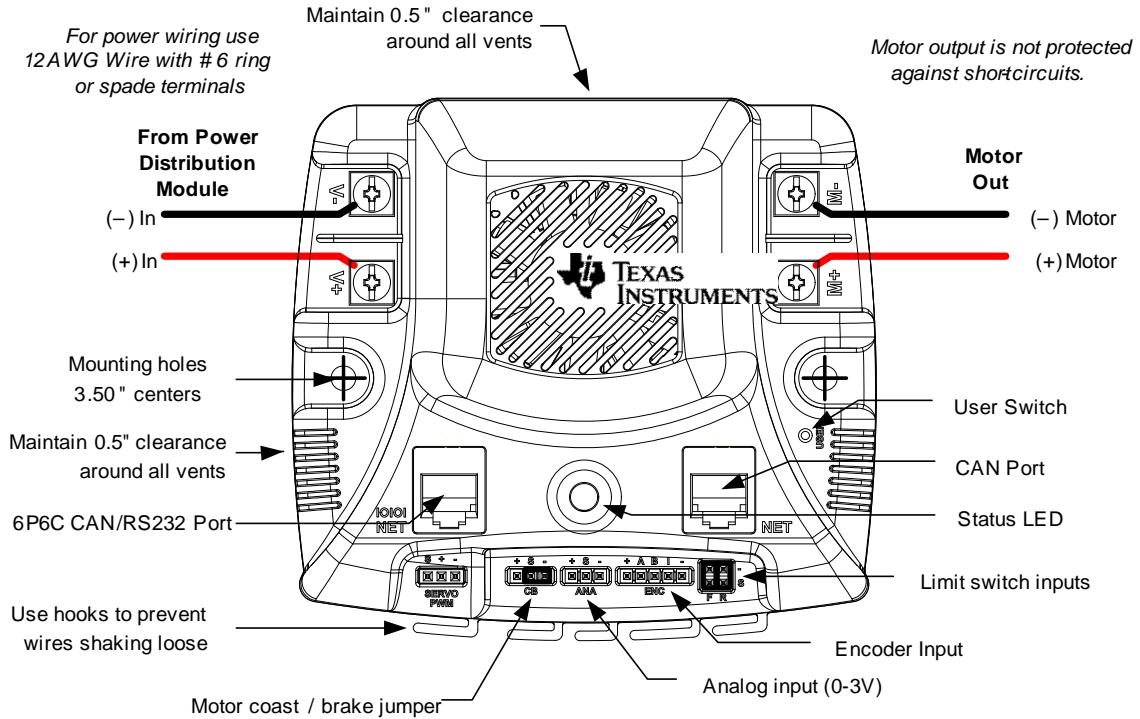

## Operational Specifications

The following tables provide the operation specifications for the MDL-BDC24 motor control board.

**WARNING – Do not exceed the maximum supply voltage of 30 V<sub>DC</sub>. Doing so will cause permanent damage to the module.**

**Table 1. Power Supply**

Parameter	Min	Typ	Max	Units
Supply voltage range (V <sub>IN</sub> )	5.5 <sup>a</sup>	12/24	30	Vdc
Supply voltage absolute maximum	–	–	35 <sup>b</sup>	Vdc
Supply current (motor off, fan off) (V <sub>IN</sub> = 12 V)	–	35	–	mA
Supply current (motor off, fan on) (V <sub>IN</sub> = 12 V)	–	105	–	mA
Under-voltage detect threshold	–	6.0	–	Vdc

a. Power supply requires V<sub>IN</sub> ≥ 7.0 V<sub>DC</sub> to start up.

b. Exceeding this limit, even momentarily, will cause permanent damage.

# BOARD DATA SHEET



**Table 2. Motor Output**

Parameter	Min	Typ	Max	Units
Motor voltage <sup>a</sup>	0	–	V <sub>IN</sub>	V
Motor current - continuous	–	–	40	A
Motor current – for 2 seconds	–	–	60	A
Motor current – peak at starting	–	–	100	A
PWM frequency	–	15.625	–	kHz
PWM resolution	–	0.1	–	%
Output current for resistive loads <sup>b</sup>	–	–	30	A

- a. The motor voltage is controlled by using a pulse-width modulated waveform.
- b. The output current for resistive loads is continuous and the value shown is the maximum value.

**Table 3. Environment**

Parameter	Min	Typ	Max	Units
Operating temperature range	0	–	50	°C
Storage temperature range	-25	–	85	°C
Fan on temperature	–	42	–	°C
Fan off temperature	–	38	–	°C

**Table 4. Servo-Style Speed Input**

Parameter	Min	Typ	Max	Units
Minimum pulse width <sup>a,b</sup>	–	0.67		ms
Neutral pulse width <sup>b</sup>	–	1.5	–	ms
Maximum pulse width <sup>b,c</sup>	–	2.33	–	ms
Servo signal period	5.0125	–	29.985	ms
Valid pulse width range	0.5	–	2.50625	ms
Duty cycle range	–	–	50	%
Digital high-level input current	2	5	25	mA
Digital low-level input current	–	–	0.3	mA
Watchdog time-out	–	100	–	ms
Voltage isolation (servo+/- to other signals) <sup>d</sup>	–	–	40	V

- a. Sets full-speed in reverse.
- b. These are the default values. Pulse-width range can be calibrated for different values. See the servo PWM calibration procedure on page 13.
- c. Sets full-speed in forward direction.
- d. The servo input is optically isolated.

# BOARD DATA SHEET



**Table 5. Analog Input**

Parameter	Min	Typ	Max	Units
Analog input voltage	0	–	3	V
Potentiometer value	–	10	–	k $\Omega$
Potentiometer reference voltage (+ pin) <sup>a</sup>	2.9	3.0	3.1	V
Measurement resolution	–	10-bit	–	bits
Measurement rate	–	15.625	–	kHz

a. With 10 k $\Omega$  potentiometer connected.

**Table 6. Voltage, Current, and Temperature Measurement**

Parameter	Min	Typ	Max	Units
Temperature measurement accuracy	–	+/- 6	–	$^{\circ}$ C
Supply voltage measurement accuracy	–	+/- 0.3	–	V
Motor current measurement accuracy $\geq$ 8A	–	+/- 1	–	A
Motor current measurement accuracy $<$ 8A	–	+/- 2	–	A
Measurement resolution	–	10	–	bits
Measurement rate	–	15.625	–	kHz

**Table 7. Brake/Coast Input**

Parameter	Min	Typ	Max	Units
Digital low-level input voltage <sup>a</sup>	-0.3	–	1.3	V
Digital high-level input voltage <sup>b</sup>	2.0	3.3	5.0	V
Digital input pull-down resistor	–	200	–	k $\Omega$
Response time	–	64	–	$\mu$ s
Power on Pin 1 (3.3 V)	–	–	25	mA

a. Selects Brake mode.

b. Selects Coast mode.

**Table 8. Quadrature Encoder Input (QEI)**

Parameter	Min	Typ	Max	Units
Digital low-level input voltage <sup>a</sup>	-0.3	–	1.3	V
Digital high-level input voltage <sup>a</sup>	2.0	3.3	5.0	V
Digital input pull-up resistor	–	10	–	k $\Omega$
Encoder rate <sup>b</sup>	DC	–	1	M
Encoder supply voltage	4.90	5.0	5.10	V

# BOARD DATA SHEET



**Table 8. Quadrature Encoder Input (QEI) (Continued)**

Parameter	Min	Typ	Max	Units
Encoder supply current	–	–	100	mA

- a. Applies to A, B, and Index inputs.
- b. Measured in transitions per second.

**Table 9. CAN Interface**

Parameter	Min	Typ	Max	Units
Bit rate	0.0133 <sup>a</sup>	1	1	Mbps
Recommended bus termination <sup>b</sup>	–	100	–	$\Omega$
Absolute maximum CANH, CANL voltage	-27	–	40	V
Watchdog time-out	–	100	–	ms
Number of nodes per network <sup>c</sup> (protocol limit)	1	–	63	#
Number of nodes per network (physical limit)	1	–	16	#
Total cable length	–	–	20 6.1	ft m

- a. Limited by fail-safe CAN transceiver SN65HVD1050.
- b. Two terminations per network.
- c. Must be a valid ID range.

**Table 10. RS232 Interface**

Parameter	Min	Typ	Max	Units
Baud rate	–	115,200	–	Baud
Format	–	8, n, 1	–	
Watchdog time-out	–	100	–	ms
RXD Absolute Maximum Voltage Range	-25	–	+25	V
TXD High-level output voltage	5	5.4	–	V
TXD Low-level output voltage	-5	-5.4	–	V
RXD Positive-going threshold	–	1.9	–	V
RXD Negative-going threshold	–	1.4	–	V

**Table 11. Limit Switch Interface**

Parameter	Min	Typ	Max	Units
Digital low-level input voltage <sup>a</sup>	-0.3	–	1.3	V
Digital high-level input voltage <sup>b</sup>	2.0	3.3	5.0	V
Pull-up resistor	–	10	–	k $\Omega$

**Table 11. Limit Switch Interface (Continued)**

Parameter	Min	Typ	Max	Units
Response time	–	64	–	μs

- a. Motor enabled state.
- b. Motor disabled state.

## Servo-style PWM Input

The MDL-BDC24 incorporates support for speed and direction control using the standard servo-style interface found on many radio-control receivers and robot controllers. See the electrical specifications for default timing of this signal.

## Electrical Interface

The Servo PWM input is electrically isolated from other circuits using an optocoupler. The MDL-BDC24 datasheet contains electrical specifications, including common-mode voltage limits, for the input stage.

**Figure 4. MDL-BDC24's Servo PWM Input Stage**

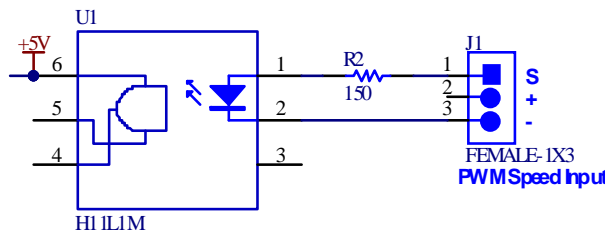

The on-board resistor (R2) has been selected to allow a signal of only a few volts to drive the optocoupler. At 3.3 V or more, it is advisable to add additional series resistance to limit the current into the LED. The PWM input stage is essentially a current-driven device, so the threshold for a logic high-level input is defined in milli-amps. Some recommended values for an external resistor are listed in Table 12.

**Table 12. Recommended External Resistor Values**

PWM Signal Level	External Series Resistor Value
2.5 V	0Ω (none)
3.0 V	0Ω - 150Ω
5.0 V	560Ω
12 V	2.2kΩ

## Power Supply

The MDL-BDC24 is designed primarily for use with 12 V or 24 V sealed lead-acid batteries, although other power sources can be used as long as the voltage range is not exceeded. See the *Brushed DC Motor Control Reference Design Kit (RDK) User's Manual* for more detail.

**NOTE:** The MDL-BDC24 does not have reverse polarity input protection.



## Motor Selection

The MDL-BDC24 operates 12 V or 24 V brushed DC motors. Typical motors include the BI802-001A model from CIM and the RS-555PH-3255 model from Mabuchi. Some very small DC motors or motors in lightly loaded applications may have a limited useful speed range. See the *Brushed DC Motor Control Reference Design Kit (RDK) User's Manual* for additional information on motor selection.

The MDL-BDC24 can also drive resistive loads with some de-rating to allow for increased ripple current inside the module.

## Operating Modes

The MDL-BDC24 can be controlled using either the servo-style PWM input or the CAN interface. Table 13 compares the capabilities of the two control methods.

**Table 13. Comparison of Control Methods**

	Control Method	
	Servo-Style PWM Input	CAN Interface
Speed Control	Yes	Yes
Analog Position Control	No	Yes
Encoder Position Control	No	Yes
Configurable Parameters	No	Yes
Voltage, Current Measurement	No	Yes
Limit Switches	Yes	Yes
Coast/Brake Feature	Yes	Yes
Firmware Update	No	Yes

The MDL-BDC24 does support the simultaneous use of CAN for monitoring and the servo-style input for speed.

**NOTE:** See the *MDL-BDC24 Getting Started Guide* for additional calibration information.

## Default Parameters

Table 14 lists the default configuration of the MDL-BDC24. Parameters can be modified using CAN commands or by modifying the software source code. Parameters changed using CAN commands are volatile and must be reloaded if power is cycled.

**Table 14. Default Factory Configuration**

Parameter	Default Value
Acceleration rate	Instantaneous change
Deceleration rate	Instantaneous change
Motor Control mode	Open-loop speed control using voltage

For additional information on parameters, see the *RDK-BDC24 Firmware Development Package User's Guide*.

## Wiring

The MDL-BDC24 is controlled using either a servo-type PWM source, CAN bus, or RS232 interface. Figure 5 shows a typical, simple wiring arrangement with power, motor, PWM control, and optional limit-switch connections. Basic servo-style PWM control is enabled by default and does not require CAN configuration.

Figure 6 on page 11 shows an advanced wiring configuration using the CAN interface. Wiring for position sensing using both a position potentiometer and a quadrature encoder is detailed. Although two sensor types are shown, the MDL-BDC24 software supports control and monitoring of only one sensor at a time.

**Figure 5. Basic Wiring with a Servo-Style Speed Command**

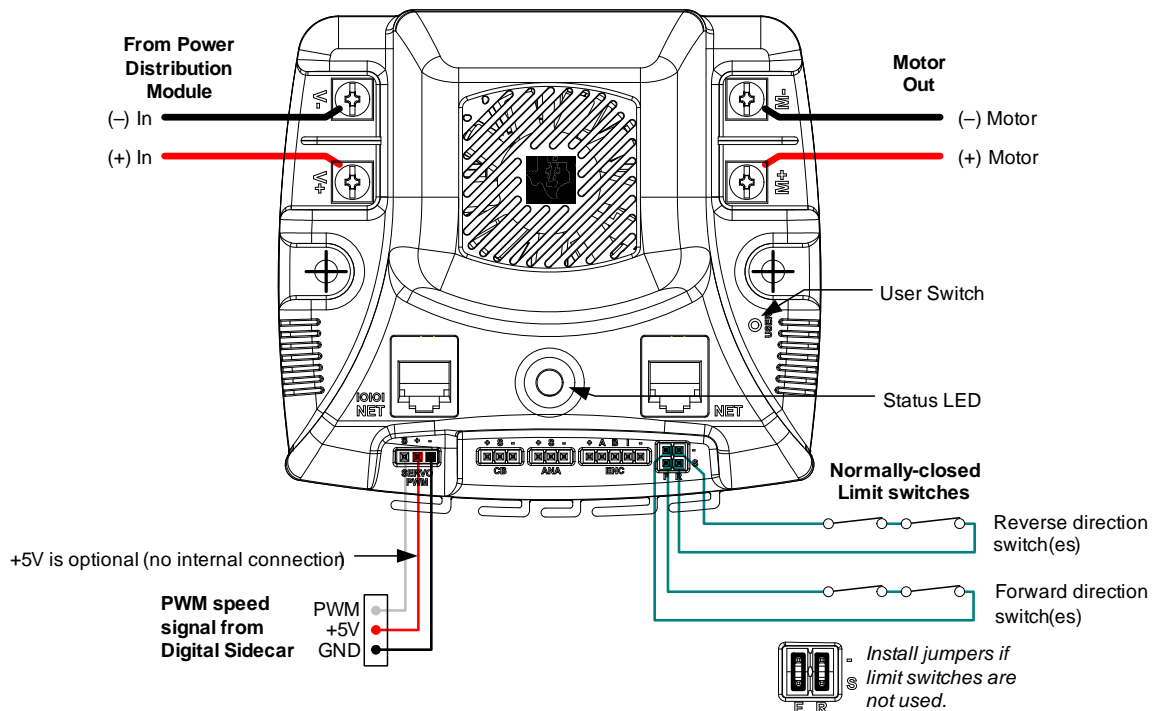

# BOARD DATA SHEET

**Figure 6. RS232/CAN-Based Control Wiring Diagram**

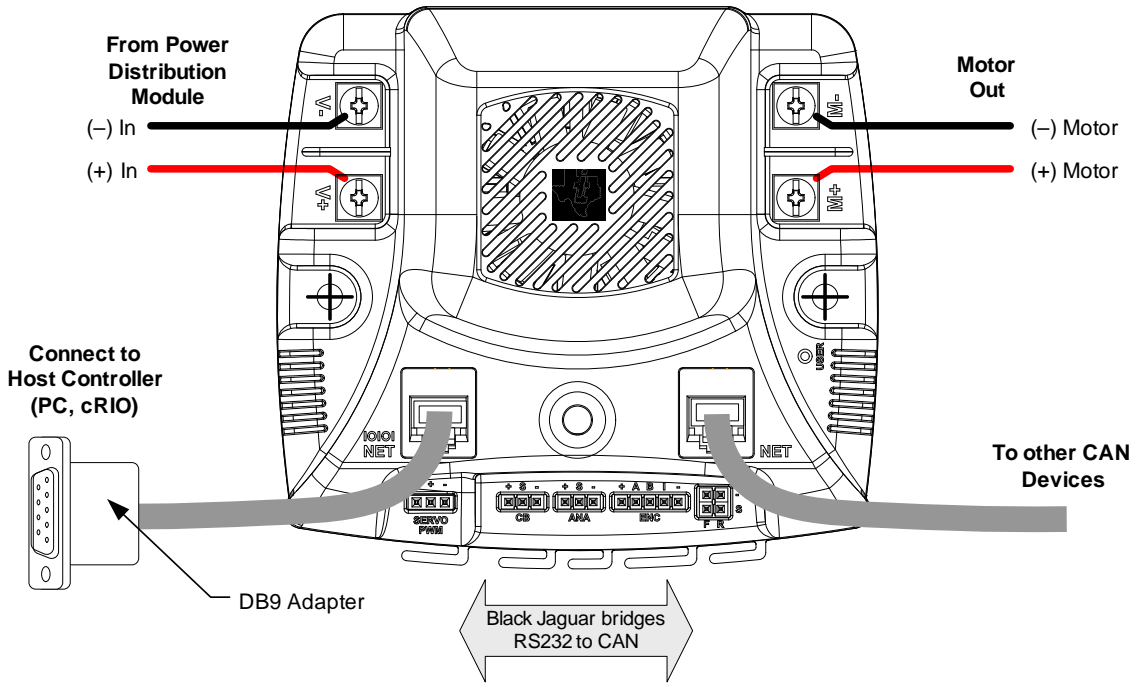

## Mechanical Details

Figure 7 shows the MDL-BDC24 physical dimensions. The module has two 0.175" (4.5 mm) diameter mounting holes as shown in Figure 7.

**Figure 7. Mechanical Drawing**

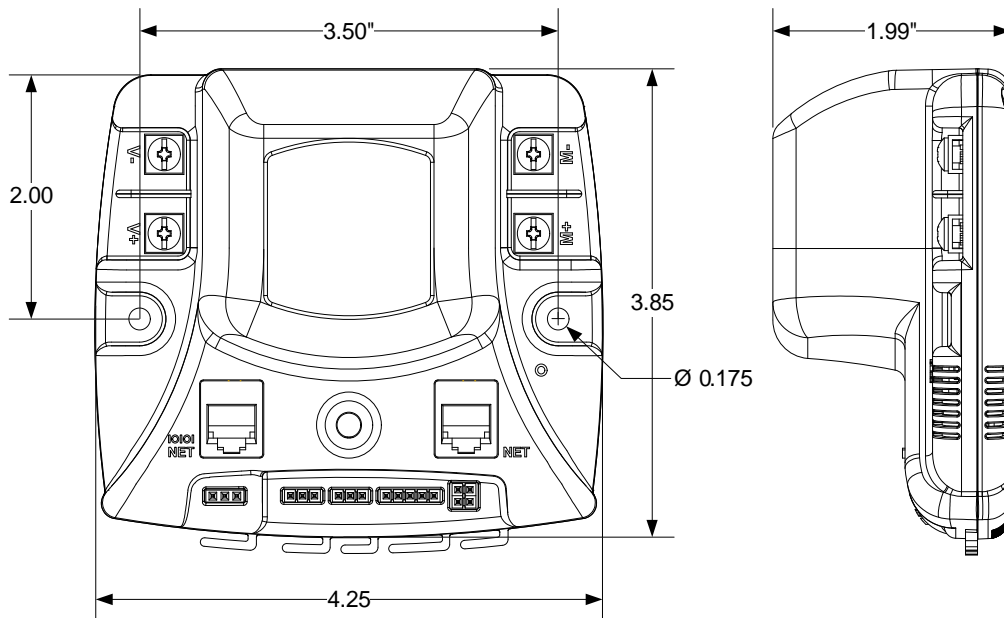

The MDL-BDC24 should be mounted so that the vents in the top and sides of the module are not restricted in any way. A clearance of 1/2 inch should be maintained around the module.

# BOARD DATA SHEET



## Status LED

Table 15 lists all of the LED status and fault codes for Normal Operating, Fault, and Calibration or CAN conditions. Fault information is prioritized, so only the highest priority fault will be indicated.

**Table 15. Normal Operating Conditions**

LED State	Module Status
<b>Normal Operating Conditions</b>	
Solid Yellow	Neutral (speed set to 0)
Fast Flashing Green	Forward
Fast Flashing Red	Reverse
Solid Green	Full-speed forward
Solid Red	Full-speed reverse
<b>Fault Conditions</b>	
Slow Flashing Yellow	Loss of CAN or servo link
Slow Flashing Red	Fault
<b>Calibration or CAN Conditions</b>	
Flashing Red and Green	Calibration mode active
Flashing Red and Yellow	Calibration mode failure
Flashing Green and Yellow	Calibration mode success
Slow Flashing Green	CAN ID assignment mode
Fast Flashing Yellow	Current CAN ID (count flashes to determine ID)
Flashing Yellow	CAN ID invalid (that is, Set to 0) awaiting valid ID assignment

## Jumper Settings

Figure 8 shows the factory-default jumper settings.

**Figure 8. Default Factory Jumper Settings**

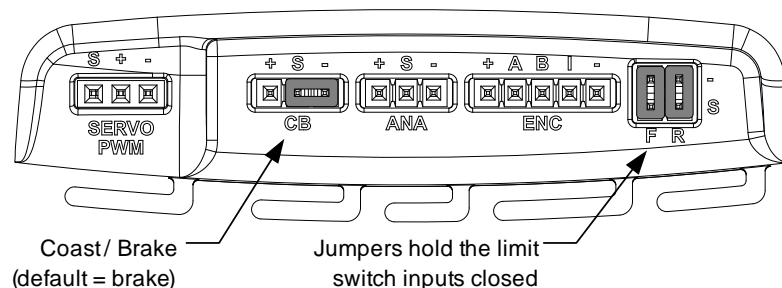

## Fault Detection

The MDL-BDC24 detects and shuts down the motor if any of the following conditions are detected:

- Power supply under-voltage
- Over temperature
- Over current
- Loss of CAN/RS232 or servo-style speed link
- Limit switch activated in the current direction of motion

The LED indicates a fault state during the fault condition and for three seconds after the fault is cleared (except for the limit switch and link faults, which are instantaneous).

## Calibration

To accommodate variation in the timing of the supplied signal, the MDL-BDC24 has a calibrate feature that sets new values for full-forward, full-reverse, and points in between.

Follow these steps to initiate calibration:

1. Hold down the user switch for five seconds.
2. Set the controller to send a full-forward signal.
3. Set the controller to send a full-reverse signal.
4. Set the controller to send a neutral signal.

The MDL-BDC24 samples these signals and centers the speed range and neutral position between these limits.

See the *MDL-BDC24 Getting Started Guide* for complete calibration procedure information.

## CAN Communication

The Controller Area Network (CAN) provides a powerful interface for controlling one or more MDL-BDC24 or MDL-BDC modules.

### Protocol

The CAN protocol used by the MDL-BDC24 includes the following capabilities:

- Firmware update over CAN
- Read supply voltage, motor voltage, temperature, and current
- Set motor voltage or target position
- Set control mode to speed or position

Each MDL-BDC24 module on the CAN bus is accessed using an assigned ID number. The ID number defaults to 1, but can be changed by sending a CAN assign ID command to the bus.

See the *RDK-BDC24 Firmware Development Package User's Guide* for complete protocol details.



## Connectors

The MDL-BDC24 has a 6P6C socket and a 6P4C socket for daisy-chaining CAN between modules using standard cables. The CAN signals on the two sockets are hard-wired to each other. Figure 9 shows the pin assignments of each connector.

Each end of the CAN network must be properly terminated. Terminator resistors can be between 100Ω and 120Ω. For more complex networks, 100Ω is recommended because it accelerates the return of differential signalling to a valid recessive state.

**Figure 9. NET Connector Pin Assignments**

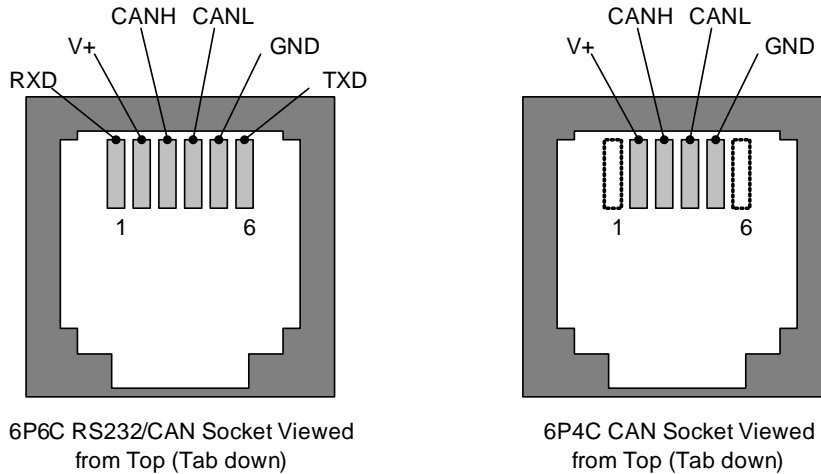

## RS232 Communication

The MDL-BDC24 supports a full set of network control and configuration functions over a standard RS232C serial interface. The command protocol is essentially the same as the protocol used on the CAN interface allowing the MDL-BDC24 to automatically bridge all commands between the RS232 and CAN interfaces.

RS232 signals are implemented on the left-side NET connector. See Figure 9 on page 14 for pin assignment information.

## Coast/Brake Input

The Coast/Brake input selects the dynamic behavior of the motor controller when decelerating or stopping. In the coast setting, the MDL-BDC24 allows the current in the motor to decay slowly, providing a more gradual deceleration. In the brake setting, the MDL-BDC24 uses switching to oppose current generated by the motor which results in much faster deceleration.

The brake setting also provides some additional holding capability in the stopped position. However, it should not be regarded as a safety or mechanical brake of any sort.

By default, the brake input is set using a jumper. Network commands can override the jumper setting, allowing the control mode to be changed dynamically. An external control signal can be connected to provide the same capability. Table 7 on page 6 lists the electrical requirements of an external control signal.

Pin 1 of the brake/coast connector can supply a small amount of 3.3 V power to an external device, as long as the device is located adjacent to the MDL-BDC24 module. See Table 7 on page 6 for electrical limits.

## Analog Input

The analog input accepts a 0-3 V sensor signal for implementing position control mode. Position control can also be implemented with a single- or multi-turn potentiometer. Potentiometers with continuous rotation are not supported. The MDL-BDC24 contains a built-in bias pin for use with 10k $\Omega$  potentiometers. If another potentiometer value or analog source is used, it must have a 0-3 V range.

If the P, I, and D parameters are positive (or zero), the MDL-BDC24 expects that a forward condition (+ voltage on White terminal, - voltage on Green) will generate an increasing voltage on the analog input.

If the P, I, and D parameters are negative (or zero), the MDL-BDC24 expects that a forward condition (+ voltage on White terminal, - voltage on Green) will generate a decreasing voltage on the analog input.

The analog input is not electrically isolated.

Table 5 on page 6 lists the electrical requirements of an external control signal.

## Encoder Input

In position control mode, the MDL-BDC24 accepts position commands over the network, and then uses an internal PID controller to autonomously move the motor to the specified position.

The QEI software position count changes on each pulse of the Encoder A input. For example, a 360° movement of a 100 pulse-per-revolution (PPR) encoder will result in a 100-count change in the position value. PPR is sometimes referred to as the number of lines that an encoder has.

The relationship between the Encoder B input and the Encoder A input determines whether the position counter increments or decrements.

An edge on the Index ("I") input resets the position counter to zero.

The MDL-BDC24 supports a wide range of shaft encoders. Encoder electrical parameters are detailed in Table 8 on page 6.

If the P, I, and D parameters are positive (or zero), the MDL-BDC24 expects that a forward condition (+ voltage on White terminal, - voltage on Green) will generate increasing counts on the encoder interface. Increasing counts occur when the rising (or falling) edge of the A input leads the rising (or falling) edge of the B input.

If the P, I, and D parameters are negative (or zero), the MDL-BDC24 expects that a forward condition (+ voltage on White terminal, - voltage on Green) will generate decreasing counts on the encoder interface. Decreasing counts occur when the rising (or falling) edge of the B input leads the rising (or falling) edge of the A input.

The MDL-BDC24 can supply 5 V power to an encoder.

## Limit Switch Inputs

Two limit switch inputs provide a method for immediate shut-down of the motor. The inputs expect typically-closed contacts - one for each direction of rotation. See Table 11 on page 7 for electrical specifications.

## Firmware Update

The MDL-BDC24 firmware can be updated over CAN and RS232. The capability to update the MDL-BDC24 firmware can be added to most Host controllers by implementing the necessary protocol. If you are not developing a CAN host controller, the BDC-COMM application provides firmware update from a Windows PC. The BDC-COMM application can be downloaded from [www.ti.com/bdc-comm](http://www.ti.com/bdc-comm).

For additional information on the firmware update procedure, see the *MDL-BDC24 Getting Started Guide*.

## Additional Information

The following documents are available for download at [www.ti.com/stellaris](http://www.ti.com/stellaris):

- *MDL-BDC24 Getting Started Guide*, Publication number MDL-BDC-GSG
- *BDC-COMM User's Guide*, Publication number MDL-BDC24-SW-UG
- *RDK-BDC24 Firmware Development Package User's Guide*, Publication number SW-RDK-BDC-UG
  - Part of the StellarisWare® source code library
- *Stellaris® Brushed DC Motor Control Module with CAN (MDL-BDC24) User's Manual*, Publication number RDK-BDC-BDC24-UM
  - Schematics and Bill-of-Materials (BOM)
  - Detailed functional description
  - Firmware update, configuration, and operation using the RDK-BDC24 test application
- *Stellaris® Brushed DC Motor Control Module with CAN (MDL-BDC24) Readme First*
  - A step-by-step guide to using the reference design kit (RDK-BDC24)



## IMPORTANT NOTICE

Texas Instruments Incorporated and its subsidiaries (TI) reserve the right to make corrections, modifications, enhancements, improvements, and other changes to its products and services at any time and to discontinue any product or service without notice. Customers should obtain the latest relevant information before placing orders and should verify that such information is current and complete. All products are sold subject to TI's terms and conditions of sale supplied at the time of order acknowledgment.

TI warrants performance of its hardware products to the specifications applicable at the time of sale in accordance with TI's standard warranty. Testing and other quality control techniques are used to the extent TI deems necessary to support this warranty. Except where mandated by government requirements, testing of all parameters of each product is not necessarily performed.

TI assumes no liability for applications assistance or customer product design. Customers are responsible for their products and applications using TI components. To minimize the risks associated with customer products and applications, customers should provide adequate design and operating safeguards.

TI does not warrant or represent that any license, either express or implied, is granted under any TI patent right, copyright, mask work right, or other TI intellectual property right relating to any combination, machine, or process in which TI products or services are used. Information published by TI regarding third-party products or services does not constitute a license from TI to use such products or services or a warranty or endorsement thereof. Use of such information may require a license from a third party under the patents or other intellectual property of the third party, or a license from TI under the patents or other intellectual property of TI.

Reproduction of TI information in TI data books or data sheets is permissible only if reproduction is without alteration and is accompanied by all associated warranties, conditions, limitations, and notices. Reproduction of this information with alteration is an unfair and deceptive business practice. TI is not responsible or liable for such altered documentation. Information of third parties may be subject to additional restrictions.

Resale of TI products or services with statements different from or beyond the parameters stated by TI for that product or service voids all express and any implied warranties for the associated TI product or service and is an unfair and deceptive business practice. TI is not responsible or liable for any such statements.

TI products are not authorized for use in safety-critical applications (such as life support) where a failure of the TI product would reasonably be expected to cause severe personal injury or death, unless officers of the parties have executed an agreement specifically governing such use. Buyers represent that they have all necessary expertise in the safety and regulatory ramifications of their applications, and acknowledge and agree that they are solely responsible for all legal, regulatory and safety-related requirements concerning their products and any use of TI products in such safety-critical applications, notwithstanding any applications-related information or support that may be provided by TI. Further, Buyers must fully indemnify TI and its representatives against any damages arising out of the use of TI products in such safety-critical applications.

TI products are neither designed nor intended for use in military/aerospace applications or environments unless the TI products are specifically designated by TI as military-grade or "enhanced plastic." Only products designated by TI as military-grade meet military specifications. Buyers acknowledge and agree that any such use of TI products which TI has not designated as military-grade is solely at the Buyer's risk, and that they are solely responsible for compliance with all legal and regulatory requirements in connection with such use.

TI products are neither designed nor intended for use in automotive applications or environments unless the specific TI products are designated by TI as compliant with ISO/TS 16949 requirements. Buyers acknowledge and agree that, if they use any non-designated products in automotive applications, TI will not be responsible for any failure to meet such requirements.

Following are URLs where you can obtain information on other Texas Instruments products and application solutions:

### Products

Audio	<a href="http://www.ti.com/audio">www.ti.com/audio</a>
Amplifiers	<a href="http://amplifier.ti.com">amplifier.ti.com</a>
Data Converters	<a href="http://dataconverter.ti.com">dataconverter.ti.com</a>
DLP® Products	<a href="http://www.dlp.com">www.dlp.com</a>
DSP	<a href="http://dsp.ti.com">dsp.ti.com</a>
Clocks and Timers	<a href="http://www.ti.com/clocks">www.ti.com/clocks</a>
Interface	<a href="http://interface.ti.com">interface.ti.com</a>
Logic	<a href="http://logic.ti.com">logic.ti.com</a>
Power Mgmt	<a href="http://power.ti.com">power.ti.com</a>
Microcontrollers	<a href="http://microcontroller.ti.com">microcontroller.ti.com</a>
RFID	<a href="http://www.ti-rfid.com">www.ti-rfid.com</a>
RF/IF and ZigBee® Solutions	<a href="http://www.ti.com/lprf">www.ti.com/lprf</a>

### Applications

Communications and Telecom	<a href="http://www.ti.com/communications">www.ti.com/communications</a>
Computers and Peripherals	<a href="http://www.ti.com/computers">www.ti.com/computers</a>
Consumer Electronics	<a href="http://www.ti.com/consumer-apps">www.ti.com/consumer-apps</a>
Energy and Lighting	<a href="http://www.ti.com/energy">www.ti.com/energy</a>
Industrial	<a href="http://www.ti.com/industrial">www.ti.com/industrial</a>
Medical	<a href="http://www.ti.com/medical">www.ti.com/medical</a>
Security	<a href="http://www.ti.com/security">www.ti.com/security</a>
Space, Avionics and Defense	<a href="http://www.ti.com/space-avionics-defense">www.ti.com/space-avionics-defense</a>
Transportation and Automotive	<a href="http://www.ti.com/automotive">www.ti.com/automotive</a>
Video and Imaging	<a href="http://www.ti.com/video">www.ti.com/video</a>
Wireless	<a href="http://www.ti.com/wireless-apps">www.ti.com/wireless-apps</a>

TI E2E Community Home Page

[e2e.ti.com](http://e2e.ti.com)

Mailing Address: Texas Instruments, Post Office Box 655303, Dallas, Texas 75265  
Copyright © 2011, Texas Instruments Incorporated