

 Russound®

Complement Series
R12DT

12" Powered Subwoofer

User's Manual





IMPORTANT SAFEGUARDS



“WARNING” TO REDUCE THE RISK OF FIRE OR ELECTRIC SHOCK, DO NOT EXPOSE THIS APPLIANCE TO RAIN OR MOISTURE.

“CAUTION” TO REDUCE THE RISK OF ELECTRIC SHOCK, DO NOT REMOVE COVER. NO USER - SERVICEABLE PARTS INSIDE. REFER SERVICING TO QUALIFIED SERVICE PERSONNEL.



The lightning flash with arrowhead symbol, within an equilateral triangle, is intended to alert the user to the presence of uninsulated “dangerous voltage” within the products enclosure that may be of sufficient magnitude to constitute a risk of electric shock to persons.



The exclamation point within an equilateral triangle is intended to alert the user to the presence of important operating and maintenance (servicing) instructions in the literature accompanying the appliance.

SAFETY INSTRUCTIONS

1. Read Instructions - All the safety and operating instructions should be read before the appliance is operated.
2. Retain Instructions - The safety and operating instructions should be retained for future reference.
3. Heed Warnings - All warnings on the appliance in the operating instructions should be adhered to.
4. Follow Instructions - All operating and user instructions should be followed.
5. Water and Moisture - To prevent fire or shock hazard do not expose this subwoofer system to rain or excessive moisture. The appliance should not be used near water - for example, near a bathtub, washbowl, kitchen sink, laundry tub, in a wet basement, or near a swimming pool, and the like.
6. Heat - The appliance should be situated away from heat sources such as radiators, heat registers, stoves, or other appliances (including amplifiers) that produce heat.
7. Power Sources - The appliance should be connected to a power supply only of the type described in the operating instructions or as marked on the appliance.
8. Grounding or Polarization - The precautions that should be taken so that the grounding or polarization means of an appliance is not defeated. The subwoofer may be equipped with a polarized alternating current line plug (a plug having one blade wider than the other). This plug will fit into the power outlet only one way. This is a safety feature. If you are unable to insert the plug fully into the outlet, try reversing the plug. If the plug is still unable to fit, contact or electrician to replace your obsolete outlet.
9. Power - Cord Protection - Power supply cords should be routed so that they are not likely to be walked on or pinched by items placed upon or against them, paying particular attention to cords at plugs, receptacles, and the point where they exit from the appliance.
10. Cleaning - The appliance should be cleaned only as recommended by the manufacturer.
11. Nonuse Periods - The power cord of the appliance should be unplugged from the outlet when left unused for a long period of time.
12. Object and Liquid Entry - Care should be taken so that objects do not fall and liquids are not spilled into the enclosure through the openings.

13. Damage Requiring Service - The appliance should be serviced by qualified service personnel when:

- A. The power - supply cord or the plug has been damaged; or
- B. Objects have fallen, or liquid has been spilled into the appliance; or
- C. The appliance has been exposed to rain; or
- D. The appliance does not appear to operate normally; or
- E. The appliance has been dropped or the enclosure is damaged.

14. Servicing - The user should not attempt to service the appliance beyond that described in the operating instructions. All other servicing should be referred to qualified service personnel.

15. The apparatus shall not be exposed to dripping or splashing and no objects filled with liquids, such as vases, shall be placed on the apparatus.

PRECAUTIONS

1. Do Not Touch The Unit With Wet Hands. Do not handle the unit or power cord when your hands are wet or damp. If water or any other liquid enters the amplifier cabinet, take the amplifier to qualified service personal for inspection.
2. Location of the Unit - Do not expose the unit to direct sun light or heating units as the amplifier internal components temperature may rise and shorten the life of the components. Avoid damp and dusty places.
3. Care – From time to time you should wipe off the front and side panels and the cabinet with a soft cloth. Do not use rough material, thinners, alcohol or other chemical solvents or cloths since this may damage the finish or remove the panel lettering.
4. Lightning – For added protection for the subwoofer during a lightning storm, or when left unattended and unused for a long period of time, unplug it from the wall outlet. This will prevent damage to the subwoofer due to a lightning strike and power-line surges.
5. Do not operate the speakers or subwoofer with the bass, treble and loudness controls set to full boost. This will place undue strain on the electronics and speakers and could damage them.
6. Whenever changing cables, pulling plugs, etc., always turn off all equipment including the subwoofer. This prevents transients from entering the speakers and prevents electrical energy from reaching the user. Keep all connections out of the reach of children.



R12DT SUBWOOFER

INTRODUCTION

The Russound R12DT active subwoofer delivers the chest-thumping deep bass sound you want for a super-sonic listening experience. Whether it's the asteroids breaking apart in your favorite sci-fi movie or the in-your-face concert experience of a classic rock band performance, the R12DT keeps up its end of the deal in your home theater or audio system. With its built-in amplifier, the R12DT fits into to any system, and is tuned for both stereo music audio and for a home theater surround setup. The R12DT filters out mid- and high-range frequencies by sending bass-only signals to its own amplifier via an active crossover network.

DUAL TUNED PORT DESIGN

The R12DT subwoofer ports are tuned to provide optimum bass reinforcement for systems designed primarily for home theater entertainment or for music listening.

With home theater systems, both ports are left open. This tuning provides an increase in low frequency output which is more ideal for movies where explosions and other action sounds need greater impact.

For music applications, one of the ports is blocked with the included plug. This tunes the enclosure for a flatter response with extended low frequency response. It will produce lower notes and do so more accurately.

CONNECTIONS

When you make connections make sure the power switches of all components are off, including the subwoofer.

Audio Cables

If you are connecting your subwoofer into a system made up of separate components (preamps and power amps), you will need audio cables long enough to reach the subwoofer from the preamplifier and the power amplifier.

Speaker Wire

Typical speaker wire has a pair of separate conductors with insulating jackets that are molded together. We recommend that you use 16-gauge wire for connecting the receiver to the front speakers.

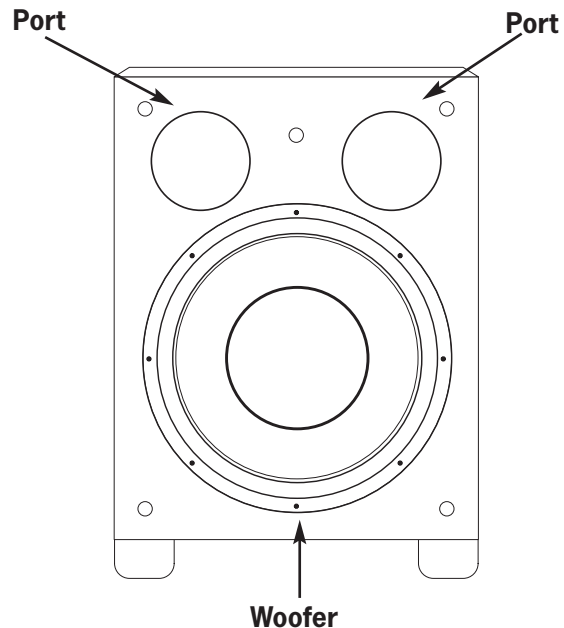

The front-firing 12-inch woofer has a 50mm diameter voice coil and vented pole piece for high power handling and more efficient operation.

Subwoofer front (grille removed)

Polarity

All speakers in a system must be connected with the same polarity. Speaker wire is marked for polarity so that you can identify which wire in the pair is which. Polarity is shown by a color strip on the insulation, by ridged molded into the insulation or be the colors of the wires, one copper and one silver.

Strip the insulation from speaker wire ends to reveal the bare conductors before connecting to receiver, subwoofer or speaker terminals.

Note: Always connect the red (+) terminal on the receiver to the red (+) terminal on the subwoofer, and the black (-) terminal on the receiver to the black (-) terminal on the subwoofer. The same is true for connecting the receiver outputs to the front speakers red (+) to red (+) and black (-) to black (-).



R12DT SUBWOOFER

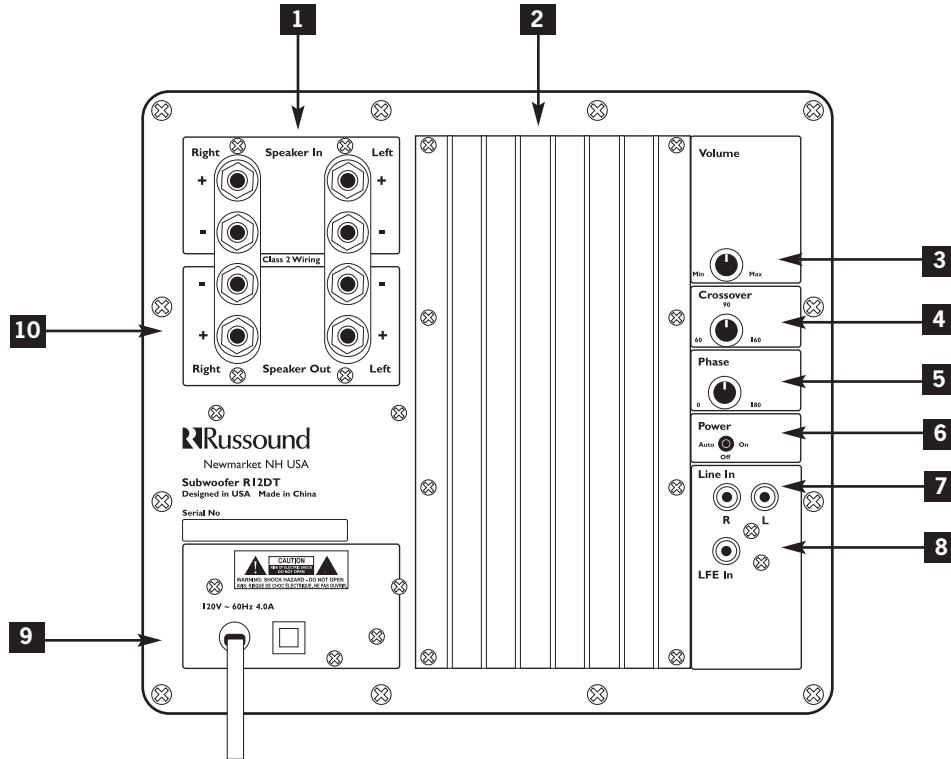

- 1 Speaker Level Input:** (with passthrough) Binding post terminals will accept up to 12 gauge speaker wire or banana jacks. Allows input connections to be sourced from an amplified speaker signal such as the Left and Right output from an amplifier/receiver. This amplified signal is tapped off for feeding the subwoofer but the signal is unaltered and is passed directly on to adjoining output terminals.
- 2 External Heat Sink:** Provides heat dissipation for the subwoofer's internal amplifier. Do not cover or place against another object as this may impair its performance.
- 3 Volume Level Adjustment:** Increase or decrease the output level relative to the incoming signal.
- 4 Crossover:** Provides active filtering of the incoming signal to allow only lower frequencies to be amplified. Adjustment range from 60Hz to 160Hz.
- 5 Phase Selection:** The speaker Phase can be variably adjusted up to 180 degrees. Used with more than one subwoofer or for abnormal room acoustics.
- 6 Power Auto, On and Off:** Auto setting - amplifier turns on when audio is detected. On - amplifier is always on. Off - amplifier is off.
- 7 Low-Level Line Input:** Left and Right channel RCA connections for low-level audio signal feed.
- 8 LFE Input:** RCA connection for pre-filtered low level signals from a processor such as home theater receiver.
- 9 Power:** Molded power cord for 120V 60Hz 4.0A power supply.
- 10 Speaker Level Output:** Binding post terminals accept banana jacks or speaker wire up to 12 gauge in size. Output terminals feed audio to the speakers which would otherwise be directly connected to the amplifier/receiver's main Left and Right outputs (those connected to the speaker level inputs).

R12DT SUBWOOFER

CONNECTION OPTIONS

Note: Choose Method A, Method B or Method C connection option. DO NOT combine them; choose only one.

Method A (Most desirable)

This configuration will have the best result for a home theater system. If your preamp receiver or processor has a subwoofer or LFE (low frequency effect) output jack that is variably controlled by the master volume control, use a single RCA audio cable to connect that output to the subwoofer's LFE in jack. This method bypasses the subwoofer's internal crossover.

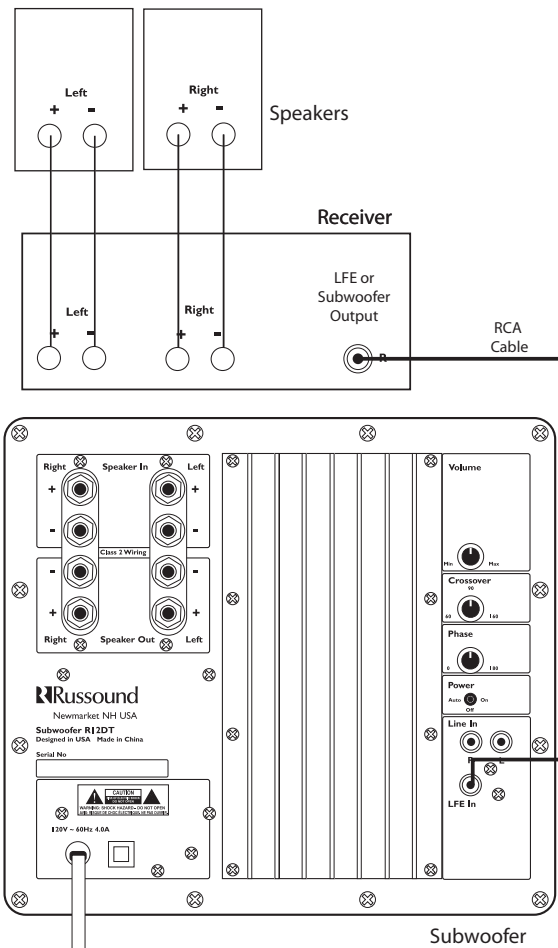

METHOD A

Method B

This method provides better sound quality and is preferred over Method C. The preamp (variable line level) outputs from the receiver carry the full range of audio signal frequency and the R12DT will use the active crossover to filter out the mid- and high-range frequencies, those which the subwoofer is not designed to reproduce.

Note: If the subwoofer is plugged into a different electrical circuit from that which supports the rest of the audio system, a ground loop may result. This causes a 60Hz low frequency hum. This can be eliminated by using the same electrical circuit or by inserting a ground loop isolation filter in line with the RCA cables.

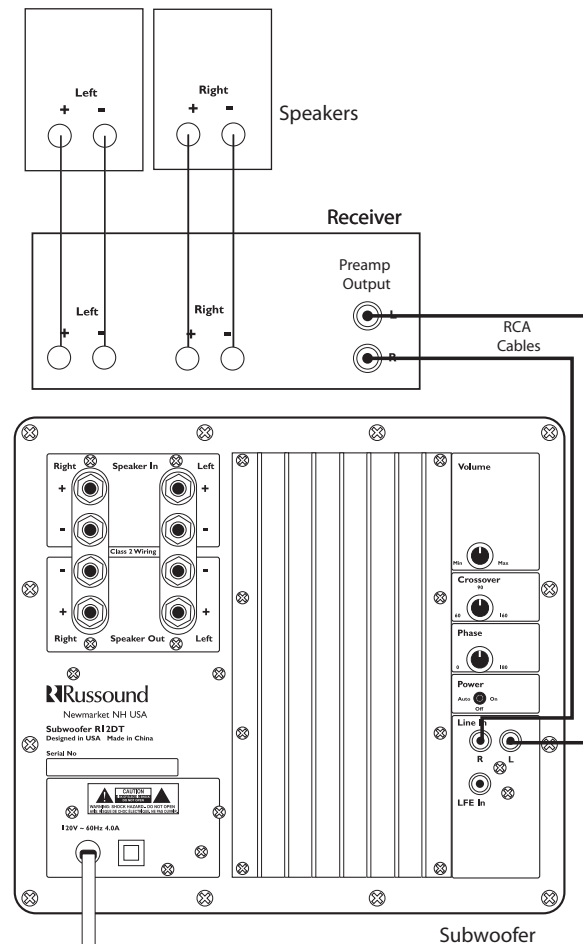

METHOD B



R12DT SUBWOOFER

Method C (Most universal installation, least desirable sonically)

This connection method allows the subwoofer to be used with virtually any audio system, but its audio output is not as clean as when line in or LFE inputs are used, as in Method A or B.

Connect speaker wire from the amplifier/receiver's main Left and Right outputs to the speaker level input on the subwoofer. Using the same size speaker wire, connect the speaker level outputs from the subwoofer to the main Left and Right speakers.

This method directly connects the main Left and Right speaker inputs to the speaker outputs, but the subwoofer amplifier taps onto the speaker level signal to get an audio feed.

This signal, being previously amplified by the amplifier/receiver, is not only too strong but also contains a certain percentage of distortion relative to the audio signal. This percentage (the lower the better) should be specified in the amplifier/receiver's manual. This signal is internally reduced to feed the amplifier for the subwoofer which will not only re-amplify the audio but also any distortion present in the signal as well.

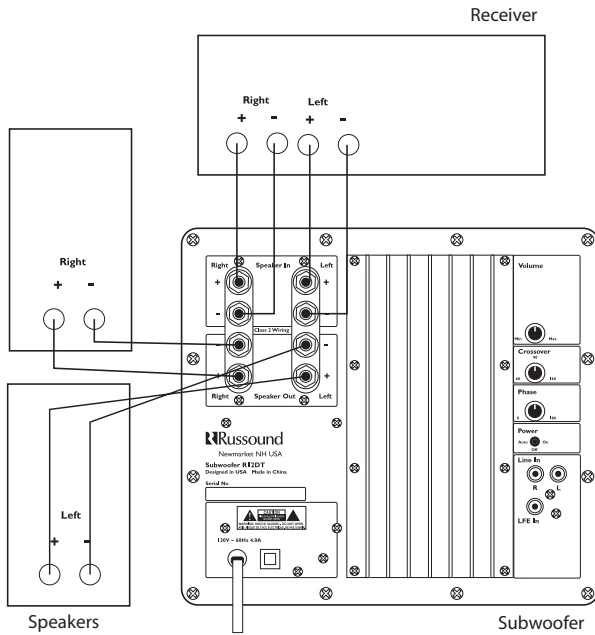

METHOD C

PLACEMENT

The R12DT subwoofer uses the sonic reflective qualities of an on-floor, corner placement to achieve optimal sound performance. The closer it is placed to a corner, the more emphasized the bass will sound. The R12DT should also be placed close enough to the audio system so that cables and wires are as short a run as possible.

Installation tip: put the subwoofer in the location where the seated listener would be connect the subwoofer and adjust for best sound. Move around the room and you will hear a difference in the subwoofer output based on your location and how the room acoustics affect it. Find the area where the subwoofer sounds the best and that is where the subwoofer should be placed. The crossover point and the volume level may be returned to compensate for slight changes that may be needed.

ADJUSTMENTS

To start, set the crossover control to its center position. This adjustment selects the frequency where the audio will start to be filtered out (Method B and C only). The higher the setting, the more signal range will be allowed, increasing output along with frequency range. Too high a setting can cause poor sound if the subwoofer is covering frequencies that are not in need of reinforcement, e.g., main speakers and subwoofer covering the same range may create undesirable levels of mid bass notes.

Phase adjustment can compensate for subwoofer placement that is irregular or too far from the listener in relation to the main speakers. Low frequencies have long wavelengths that have peaks and low spots. If these do not align with the main speakers, there can be bass cancellation. Adjusting the phase can correct this.

Set the volume level control fully counterclockwise to minimum. This should be reset after making other adjustments.

**SPECIFICATIONS**

Driver Complement and Enclosure:	Front-firing 12" long throw woofer with dual ports
Voice Coil:	50mm dia.
Frequency Response:	25Hz to 160Hz +/- 3dB
Amplification:	200 watts continuous power into 4 ohm load
THD+N:	1.0%
Crossover Frequency (-3dB):	60Hz @ Min., 160Hz @ Max.
Audio Input:	RCA Line Level and Speaker Level
Power requirements:	120VAC 60Hz 4.0A Molded 2-terminal power cord.
Dimensions:	14.4" W x 18.3" D x 20.3" H (36.5 x 46.5 x 51.6 cm)
Weight:	50.0 lbs. (22.7 kg)

WARRANTY

The Russound R12DT is fully guaranteed for two (2) years from the date of purchase against all defects in materials and workmanship. During this period Russound will replace any defective parts and correct any defect in workmanship without charge for either parts or labor. For this warranty to apply, the unit must be installed and used according to its written instructions. If service is necessary, it must be performed by Russound. The unit must be returned to Russound at the owners expense and with prior written permission. Accidental damage and shipping damage are not considered defects under the terms of the warranty. Russound assumes no responsibility for defects resulting from abuse or servicing performed by an agency or person not specifically authorized in writing by Russound. Damage to or destruction of components due to improper use voids the warranty. In these cases the repair will be made at the owners expense. To return for repairs, the unit must be shipped to Russound at the owners expense, along with a note explaining the nature of the service required. Be sure to pack in a corrugated container with at least 3 inches of resilient material to protect the unit from damage in transit.

Russound sells products only through authorized Dealers and Distributors to ensure that customers obtain proper support and service. Any Russound product purchased from an unauthorized dealer or source, including retailers, mail order sellers and online sellers will not be honored or serviced under existing Russound warranty policy. Any sale of products by an unauthorized source or other manner not authorized by Russound shall void the warranty on the applicable product.



Complement Series R12DT Powered Subwoofer

User's Manual

5 Forbes Rd. Newmarket, NH 03857, USA
Tel 603.659.5170 • Fax 603.659.5388
e-mail: tech@russound.com

28-1173

01/04/05

Copyright © 2005 Russound® All rights reserved.