

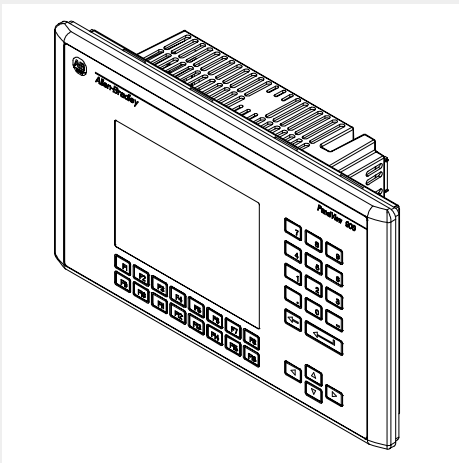

Allen-Bradley

*PanelView
Operator Terminals*

User Manual



Important User Information

Because of the variety of uses for the products described in this publication, those responsible for the application and use of this control equipment must satisfy themselves that all necessary steps have been taken to assure that each application and use meets all performance and safety requirements, including any applicable laws, regulations, codes and standards.

The illustrations, charts, sample programs and layout examples shown in this guide are intended solely for purposes of example. Since there are many variables and requirements associated with any particular installation, Allen-Bradley does not assume responsibility or liability (to include intellectual property liability) for actual use based upon the examples shown in this publication.

Allen-Bradley publication SGI-1.1, *Safety Guidelines for the Application, Installation and Maintenance of Solid-State Control* (available from your local Allen-Bradley office), describes some important differences between solid-state equipment and electromechanical devices that should be taken into consideration when applying products such as those described in this publication.

Reproduction of the contents of this copyrighted publication, in whole or part, without written permission of Allen-Bradley Company, Inc., is prohibited.

Throughout this manual we use notes to make you aware of safety considerations:



ATTENTION: Identifies information about practices or circumstances that can lead to personal injury or death, property damage or economic loss.

Attention statements help you to:

- identify a hazard
- avoid a hazard
- recognize the consequences

Important: Identifies information that is critical for successful application and understanding of the product.

PanelBuilder, PanelView, SLC, SLC 500, SLC 5/01, SLC 5/02, SLC 5/03, SLC 5/0, MicroLogix, ControlLogix, Data Highway Plus are trademarks of Allen-Bradley Company, Inc.
PLC and PLC-5 are registered trademarks of Allen-Bradley, Inc.
Microsoft, MS-DOS and Windows are trademarks or registered trademarks of Microsoft Corporation.

Table of Contents

Preface

Preface ObjectivesP-1
Contents of ManualP-2
Intended AudienceP-3
ConventionsP-3
TerminologyP-3
Installing PanelView TerminalsP-3
European Union Directive ComplianceP-3
Related PublicationsP-4
Technical SupportP-4
Technical Product AssistanceP-4

Terminal Overview

Chapter 1

Intended Uses 1-1
Terminal Types1-1
Color and Grayscale Terminals1-5
PanelView 550 Features1-6
PanelView 600 Features1-12
PanelView 900/1000 Features.....1-16
PanelView 1400 Features1-20
Applications1-24
Touch Screen Operation1-25
Keypad Operation1-25
Configuration Mode Menu1-26
Terminal Messages1-26
Printing1-26
Alarm List1-27
Accessories1-28
Replacement Parts1-30

Initial Setup

Chapter 2

Chapter Objectives2-1
Wiring and Safety Guidelines2-1
Connecting AC Power2-2
Connecting DC Power2-5
Resetting the Terminal2-7
Power-up Sequence2-8

Configuring the Terminal

Chapter 3

Chapter Objectives	3-1
Application Settings	3-1
Accessing the Configuration Mode Menu	3-2
Selecting a Language	3-4
Using a Memory Card	3-5
Configuring Communications	3-6
DH-485 Communications	3-6
DH+ Communications	3-8
Remote I/O Communications	3-9
ControlNet Communications	3-10
DeviceNet Communications	3-12
DF1 Communications	3-14
Configuring Presets	3-16
Viewing Terminal Information	3-17
Adjusting Screen Parameters	3-18
Setting the Time and Date	3-25
Setting up the Printer	3-26

Using a Memory Card

Chapter 4

Chapter Objectives	4-1
Supported Memory Cards	4-1
Using the Memory Card Retainer	4-2
Loading Application from a Memory Card	4-4
Loading Application on a Memory Card	4-6
Storing Font Files on a Memory Card	4-8
Removing a Memory Card	4-8

Running Applications

Chapter 5

Chapter Objectives	5-1
Application Information	5-1
Push Button Operation	5-2
Control Lists	5-3
Numeric Entry Controls	5-6
Screen Selectors	5-8
List Indicators	5-10
Multistate Indicators	5-10
Bar Graph Displays	5-10
Numeric Data Displays	5-11
Message Displays	5-11
Time or Date	5-11
Printing	5-12
Alarms	5-12

Installing the PV550 Terminal	Chapter 6
	Chapter Objectives6-1
	Hazardous Locations6-1
	Enclosures6-2
	Required Tools6-2
	Mounting Dimensions6-2
	Clearances6-3
	Cutout Dimensions6-4
	Installing the PV550 in a Panel6-5
Installing the PV600 Terminal	Chapter 7
	Chapter Objectives7-1
	Hazardous Locations7-1
	Enclosures7-1
	Required Tools7-2
	Mounting Dimensions7-2
	Cutout Dimensions7-2
	Clearances7-3
	Installing the PV600 in a Panel7-4
Installing the PV900/1000 Terminals	Chapter 8
	Chapter Objectives8-1
	Hazardous Locations8-1
	Enclosures8-1
	Required Tools8-2
	Mounting Dimensions8-2
	Clearances8-4
	Cutout Dimensions8-5
	Installing the PV900/PV1000 in a Panel8-6
Installing the PV1400 Terminal	Chapter 9
	Chapter Objectives9-1
	Enclosures9-1
	Required Tools9-1
	Mounting Dimensions9-2
	Clearances9-3
	Cutout Dimensions9-4
	Installing the PV1400 in a Panel9-5

**Making Terminal
Connections****Chapter 10**

Chapter Objectives	10-1
Wiring and Safety Guidelines	10-1
Remote I/O Terminal Connections	10-2
DH-485 Terminal Connections	10-6
DH+ Terminal Connections	10-13
RS-232 Terminal Connections	10-16
ControlNet Connections	10-20
DeviceNet Terminal Connections	10-25
DF1 Terminal Connections	10-27
Connecting a Computer or Printer to Terminal.	10-30

**Troubleshooting and
Maintenance****Chapter 11**

Chapter Objectives	11-1
Equipment Required	11-1
Using the Troubleshooting Chart	11-1
LED Indicators	11-4
Cleaning the Display Window	11-5
Replacing the Clock Module	11-5
Replacing the Backlight	11-5

Appendix A**Specifications****Appendix B****Messages, Codes and Self-Test Numbers****Appendix C****European Union Directive Compliance****Glossary****Index**

Preface

Read this preface to familiarize yourself with the rest of this manual.

- contents of this manual
- intended audience
- conventions used
- terminology
- installing PanelView terminals
- European Union Directive Compliance
- related publications
- technical support

Contents of Manual

The following table gives an overview of this manual.

Chapter	Title	Purpose
1	Terminal Overview	Describes features of the PanelView terminals.
2	Initial Setup	Describes how to apply power and reset the PanelView terminals.
3	Configuring the Terminal	Shows how to configure the terminal using the Configuration Mode menu.
4	Using a Memory Card	Tells how to copy applications to and from a memory card.
5	Running Applications	Describes objects common to most applications.
6	Installing the PanelView 550 Terminal	Shows how to mount the PanelView 550 terminal in an enclosure or panel.
7	Installing the PanelView 600 Terminal	Shows how to mount the PanelView 600 terminal in an enclosure or panel.
8	Installing the PanelView 900/1000 terminal	Shows how to mount the PanelView 900 or 1000 terminal in an enclosure or panel.
9	Installing the PanelView 1400 Terminal	Shows how to mount the PanelView 1400 terminal in an enclosure or panel.
10	Making Terminal Connections	Describes connections for the Remote I/O, DH-485, DH+, RS-232, DF1, ControlNet and DeviceNet versions of the PanelView terminals. Also shows how to connect a computer or printer to terminals with an RS-232 serial port.
11	Troubleshooting and Maintenance	Provides assistance in identifying and correcting common operating problems. Also gives procedures for routine maintenance.

Intended Audience

No special knowledge is required to understand this manual or operate the PanelView terminals. Before running an application, you must know the functions of all screens and screen objects. This information is available from the application designer.

Equipment installers must be familiar with standard panel installation techniques.

Conventions

The manual uses the following conventions:

- PV550 refers to the PanelView 550 terminal.
- PV600 refers to the PanelView 600 terminal.
- PV900 refers to the PanelView 900 terminal.
- PV1000 refers to the PanelView 1000 terminal.
- PV1400 refers to the PanelView 1400 terminal.
- PanelView terminal refers to any one of the PanelView terminals.

Terminology

This manual contains some terms that may be unfamiliar. Use the glossary of this manual for assistance.

Installing PanelView Terminals

Each terminal is shipped with installation instructions and a panel cutout. Please follow these instructions when installing your PanelView terminal in a panel or enclosure.

European Union Directive Compliance

Refer to Appendix C for details on installing the PanelView terminals in industrial environments requiring compliance with European Union Directives.

Related Publications

Refer to the following publications if necessary.

Publication	Description
2711-6.0	PanelBuilder Software User Manual
2711-6.2	Getting Started with PanelBuilder User Manual
2711-6.3	PROFIBUS DP Communications for PanelView Terminals
2711-6.0.4	DeviceNet Communications for PanelView Terminals
2711-6.10	ControlNet Communications for PanelView Terminals
2711-805	PanelView File Transfer Utility
1770-4.1	Programmable Controller Wiring and Grounding Guidelines
1770-6.2.2	Data Highway/Data Highway Plus/Data Highway-485 Cable Installation Manual
1785-5.7	Enhanced PLC-5 Programmable Controllers Installation-Instructions

For information relating to your controller, refer to the appropriate manual.

Technical Support

Allen-Bradley offers support services worldwide, with over 75 Sales/Support Offices, 512 authorized Distributors and 260 authorized Systems Integrators located throughout the United States alone, plus Allen-Bradley representatives in every major country in the world.

Local Product Support

Contact your local Allen-Bradley representative for:

- sales and order support
- product technical training
- warranty support
- support service agreements

Technical Product Assistance

If you need to contact Allen-Bradley for technical assistance, please review the information in Chapter 11 on *Troubleshooting* first. Then call your local Allen-Bradley representative.

Terminal Overview

This chapter gives an overview of the PanelView Operator Terminals.

- intended uses
- terminal types and features
- applications
- configuration mode
- terminal messages
- printing
- accessories and replacement parts

Intended Uses

You can use the PanelView operator terminals for a wide variety of machine control and monitoring applications.



ATTENTION: Do not use a PanelView terminal for emergency stops or other controls critical to the safety of personnel or equipment. Use separate hardwired operator interface devices that do not depend on solid state electronics. See the inside front cover of this manual for guidelines.

Terminal Types

PanelView terminals are available in a variety of options. Differences are in:

- display size and type (monochrome, grayscale, color)
- operator input (touch screen or keypad)
- communication port (DH-485, RS-232, Remote I/O, DH+, ControlNet, DeviceNet, DF1)
- RS-232 printer port support

In addition, some terminals are available with:

- AC or DC power (L1 at the end of a catalog number indicates a DC terminal, for example, 2711-B5A1L1, or -T9C1L1).
- Stainless steel (L2 indicates a stainless steel terminal with AC power, 2711-T9C1L2. L3 indicates a stainless steel terminal with DC power, 2711-T9C1L3.)

Contact your Allen-Bradley representative for availability.

PanelView 550 Monochrome Terminals

The Touch Screen version of the PanelView 550 terminal is available only with 24V DC power. The L1 in the catalog number indicates DC power.

Operator Input	Communication Ports							Printer Port RS-232	Catalog ¹ Number
	RIO	DH-485	RS-232	DH+	DeviceNet	ControlNet	DF1		
Touch Screen and Keypad	✓							✓	2711-B5A1
		✓							2711-B5A2
		✓						✓	2711-B5A3
			✓						2711-B5A5
				✓				✓	2711-B5A8
			✓					✓	2711-B5A9
					✓			✓	2711-B5A10
						✓		✓	2711-B5A15
Keypad							✓	✓	2711-B5A16
	✓							✓	2711-K5A1
		✓							2711-K5A2
		✓						✓	2711-K5A3
			✓						2711-K5A5
				✓				✓	2711-K5A8
			✓					✓	2711-K5A9
					✓			✓	2711-K5A10
Touch Screen (24V dc only)							✓	✓	2711-K5A15
								✓	2711-K5A16
	✓							✓	2711-T5A1L1
		✓							2711-T5A2L1
		✓						✓	2711-T5A3L1
			✓						2711-T5A5L1
				✓				✓	2711-T5A8L1
			✓					✓	2711-T5A9L1
Touch Screen (24V dc only)					✓			✓	2711-T5A10L1
						✓		✓	2711-T5A15L1
							✓	✓	2711-T5A16L1

¹ Add L1 to the end of a catalog number for 24V dc power.
 Add L2 to the end of a catalog number for stainless steel. Not available for the touch screen terminals.
 Add L3 to the end of a catalog number for 24V dc power and stainless steel. Stainless steel is not available for the touch screen terminals.

PanelView 600 Color Terminals

Operator Input	Communication Ports							Printer Port RS-232	Catalog ¹ Number
	RIO	DH-485	RS-232	DH+	DeviceNet	ControlNet	DF1		
Touch Screen and Keypad	✓							✓	2711-B6C1
		✓							2711-B6C2
		✓						✓	2711-B6C3
			✓						2711-B6C5
				✓				✓	2711-B6C8
			✓					✓	2711-B6C9
					✓			✓	2711-B6C10
						✓		✓	2711-B6C15
Keypad							✓	✓	2711-B6C16
	✓							✓	2711-K6C1
		✓							2711-K6C2
		✓						✓	2711-K6C3
			✓						2711-K6C5
				✓				✓	2711-K6C8
			✓					✓	2711-K6C9
					✓			✓	2711-K6C10
					✓		✓	2711-K6C15	
						✓	✓	2711-K6C16	

¹ L1 added to the end of a catalog number indicates 24V dc power.

PanelView 900 Monochrome Terminals

Operator Input	Communication Ports							Printer Port RS-232	Catalog ¹ Number
	RIO	DH-485	RS-232	DH+	DeviceNet	ControlNet	DF1		
Touch Screen	✓							✓	2711-T9A1
		✓							2711-T9A2
		✓						✓	2711-T9A3
			✓						2711-T9A5
				✓				✓	2711-T9A8
			✓					✓	2711-T9A9
					✓			✓	2711-T9A10
						✓		✓	2711-T9A15
Keypad							✓	✓	2711-K5A16
	✓							✓	2711-K9A1
		✓							2711-K9A2
		✓						✓	2711-K9A3
			✓						2711-K9A5
				✓				✓	2711-K9A8
			✓					✓	2711-K9A9
					✓			✓	2711-K9A10
					✓		✓	2711-K9A15	
						✓	✓	2711-K9A16	

¹ L1 added to the end of a catalog number indicates 24V dc power.

PanelView 900 Color Terminals

Operator Input	Communication Ports							Printer Port RS-232	Catalog ¹ Number
	RIO	DH-485	RS-232	DH+	DeviceNet	ControlNet	DF1		
Touch Screen	✓							✓	2711-T9C1
		✓						✓	2711-T9C3
				✓				✓	2711-T9C8
			✓					✓	2711-T9C9
					✓			✓	2711-T9C10
						✓		✓	2711-T9C15
Keypad							✓	✓	2711-T9C16
	✓							✓	2711-K9C1
		✓						✓	2711-K9C3
				✓				✓	2711-K9C8
			✓					✓	2711-K9C9
					✓			✓	2711-K9C10
					✓		✓	2711-K9C15	
						✓	✓	2711-K9C16	

¹ L1 added to the end of a catalog number indicates 24V dc power.

PanelView 1000 Color Terminals

Operator Input	Communication Ports							Printer Port RS-232	Catalog ¹ Number
	RIO	DH-485	RS-232	DH+	DeviceNet	ControlNet	DF1		
Touch Screen	✓							✓	2711-T10C1
		✓						✓	2711-T10C3
				✓				✓	2711-T10C8
			✓					✓	2711-T10C9
					✓			✓	2711-T10C10
						✓		✓	2711-T10C15
Keypad							✓	✓	2711-T10C16
	✓							✓	2711-K10C1
		✓						✓	2711-K10C3
				✓				✓	2711-K10C8
			✓					✓	2711-K10C9
					✓			✓	2711-K10C10
					✓		✓	2711-K10C15	
						✓	✓	2711-K10C16	

¹ L1 added to the end of a catalog number indicates 24V dc power.

PanelView 1000 Grayscale Terminals

Operator Input	Communication Ports							Printer Port RS-232	Catalog ¹ Number
	RIO	DH-485	RS-232	DH+	DeviceNet	ControlNet	DF1		
Touch Screen	✓							✓	2711-T10G1
		✓						✓	2711-T10G3
				✓				✓	2711-T10G8
			✓					✓	2711-T10G9
					✓			✓	2711-T10G10
						✓		✓	2711-T10G15
							✓	✓	2711-T10G16
Keypad	✓							✓	2711-K10G1
		✓						✓	2711-K10G3
				✓				✓	2711-K10G8
			✓					✓	2711-K10G9
					✓			✓	2711-K10G10
						✓		✓	2711-K10G15
							✓	✓	2711-K10G16

¹ L1 added to the end of a catalog number indicates 24V dc power.

PanelView 1400 Color Terminals

Operator Input	Communication Ports							Printer Port RS-232	Catalog ¹ Number
	RIO	DH-485	RS-232	DH+	DeviceNet	ControlNet	DF1		
Touch Screen	✓							✓	2711-T14C1
		✓						✓	2711-T14C3
				✓				✓	2711-T14C8
			✓					✓	2711-T14C9
					✓			✓	2711-T14C10
						✓		✓	2711-T14C15
							✓	✓	2711-T14C16
Keypad	✓							✓	2711-K14C1
		✓						✓	2711-K14C3
				✓				✓	2711-K14C8
			✓					✓	2711-K14C9
					✓			✓	2711-K14C10
						✓		✓	2711-K14C15
							✓	✓	2711-K14C16

Color and Grayscale Terminals

Color terminals support a fixed palette of 16 standard EGA colors. Grayscale terminals support a fixed palette of 4 colors (shades of gray). All color in an application is defined when the application is created. Colors are not selectable at the terminal.

PanelView 550 Features

This section defines features of the PanelView 550 terminals.

PanelView 550 Features (Front)

Keypad Terminal

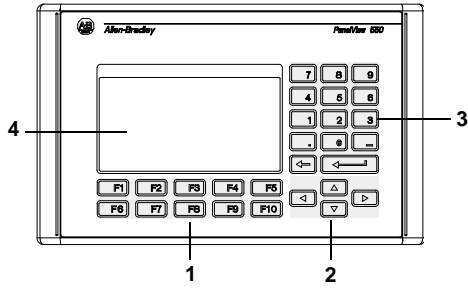

Keypad & Touch Screen Terminal

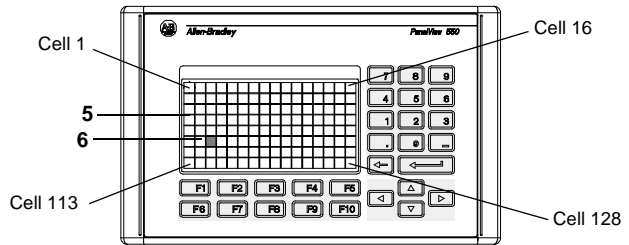

Touch Screen Terminal

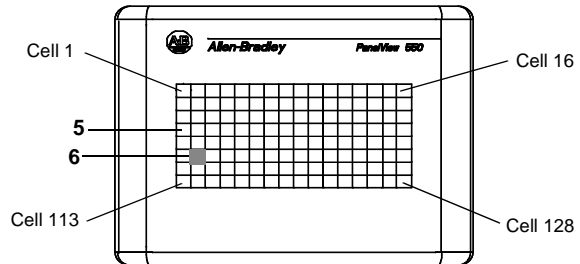

#	Feature	Description
1	Function Keys (F1 - F10)	<p>On keypad terminals, use the function keys to initiate functions on the terminal display. These keys may have custom legends.</p> <p>On keypad & touch screen terminals, you can initiate functions using the function keys and/or touch screen objects.</p>
2	Cursor Keys	Use the cursor keys to move the cursor in displayed lists, to select a numeric entry object, or to enter configuration mode.
3	Numeric Entry Keys	<p>0-9 Enters numeric values.</p> <p>. Enters a decimal point.</p> <p>- Enters a negative value.</p> <p>← Clears entered digits or cancels the scratchpad.</p> <p>↵ Stores an entered value.</p>
4	Keypad Terminal Display	On keypad terminals, initiate the function of a displayed object, such as an ON or OFF push button, by pressing a function key (F1 - F10).
5	Touch Screen Terminal Display	<p>On touch screen or keypad & touch screen terminals, initiate the function of a displayed object, such as an ON or OFF push button, by touching the screen object. Each interactive screen object occupies one or more of 128 cells.</p> <p>On keypad & touch screen terminals, you can initiate functions using the function keys and/or touch screen objects.</p>
6	Touch Cells (Touch Screen terminal)	The 128 touch cells (16 columns x 8 rows) let you initiate functions by touching the screen. Interactive screen objects are aligned with touch cells when the application is created.

PanelView 550 Keypad or Keypad & Touch Screen Terminals (Back)

DH-485 Version without RS-232 Port

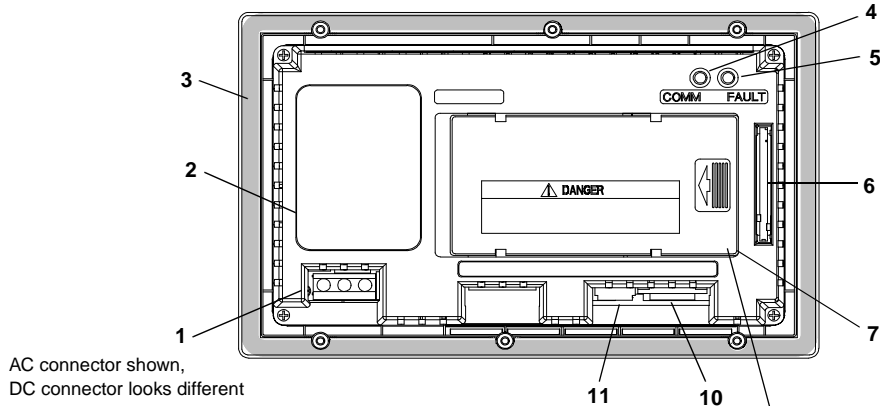

DH-485 Version with RS-232 Port

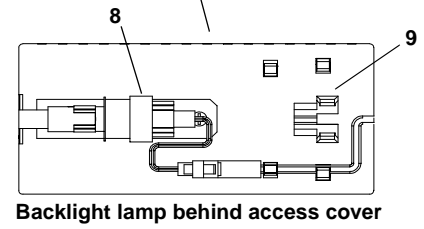
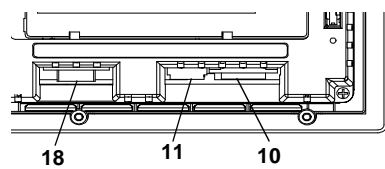

RS-232 Version

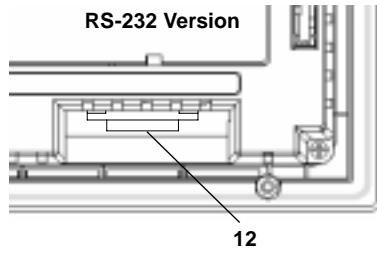

Remote I/O, DH+, DeviceNet, ControlNet or DF1 Version with RS-232 Port

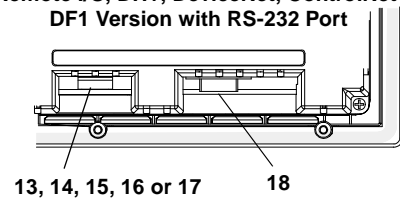

RS-232 Version with additional RS-232 Port

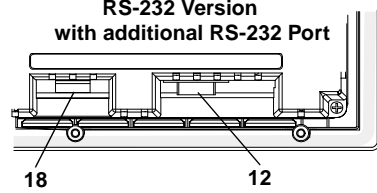

#	Feature	Description
1	Power Connection Terminals	Connects to external power source.
2	Nameplate Label	Provides product information.
3	Sealing Gasket	Seals the front of the terminal to an enclosure or panel.
4	COMM LED (Green)	Indicates when communications is occurring.
5	FAULT LED (Red)	Indicates firmware or hardware faults.
6	Memory Card Slot	Accepts a memory card which stores applications.
7	Access Cover	Provides access to the replaceable backlight lamp.
8	Backlight Lamp	Light source for the display backlight. Light transmits through a fiber-optic bundle to the back of the LCD display.
9	Spare Bulb Holder	Stores a spare backlight lamp.
10	DH-485 Communication Port	Connects to an SLC controller, DH-485 network, or Wallmount Power Supply (Cat. No. 1747-NP1).
11	DH-485 Programming Connector	Connects to a Personal Computer Interface Converter (Cat. No. 1747-PIC) for transferring applications. Also connects to an SLC programmer, such as the Hand-Held Terminal (Cat. No. 1747-PT1).
12	RS-232 Communication Port	Connects to the Channel 0 port of an SLC 5/03 or 5/04 controller for point-to-point DH-485 communications. Also connects to the RS-232 serial port of a computer for transferring applications. Channel 0 Port is configured for DH-485 communications using the Advanced Programming Software.
13	Remote I/O Port	Connects to a scanner or sub-scanner on a Remote I/O network.
14	DH+ Communication Port	Connects to a PLC or SLC 5/04 controller on a DH+ link.
15	DeviceNet Connector	Connects to a DeviceNet network.
16	ControlNet Connectors	Connects to a ControlNet network.
17	DF1 Communication Port	Connects to a PLC, SLC or MicroLogix controller with a DF1 port.
18	RS-232 Printer/ File Transfer Port	Connects to a printer. On Remote I/O, DH+, DeviceNet and ControlNet terminals, this port also connects to the RS-232 port of a computer for transferring applications.

PanelView 550 Touch Screen Terminal Features (Back)

DH-485 Version without RS-232 Port

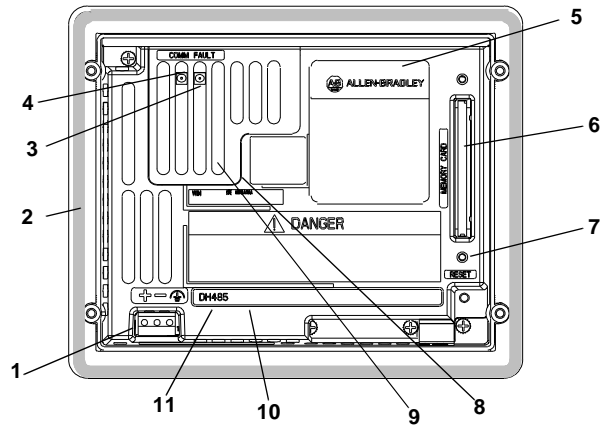

DH-485 Version with RS-232 Port

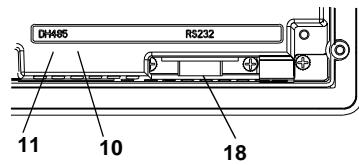

Backlight lamp behind access cover

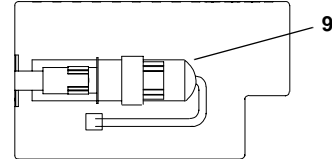

RS-232 Version

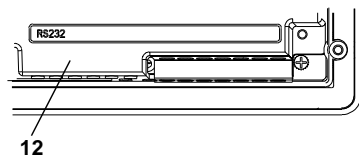

Remote I/O, DH+, DeviceNet, ControlNet or DF1 Version with RS-232 Port

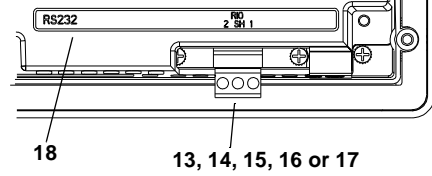

RS-232 Version with additional RS-232 Port

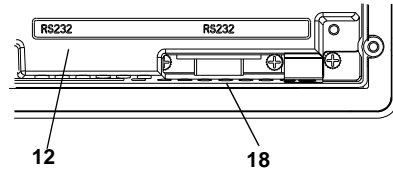

#	Feature	Description
1	Power Connection Terminals	Connects to external DC power source.
2	Sealing Gasket	Seals the front of the terminal to an enclosure or panel.
3	FAULT LED (Red)	Indicates firmware or hardware faults.
4	COMM LED (Green)	Indicates when communications is occurring.
5	Nameplate Label	Provides product information.
6	Memory Card Slot	Accepts a memory card which stores applications.
7	Reset Button	Resets the terminal.
8	Access Cover	Provides access to the replaceable backlight lamp.
9	Backlight Lamp	Light source for the display backlight.
10	DH-485 Communication Port	Connects to an SLC controller, DH-485 network, or Wallmount Power Supply (Cat. No. 1747-NP1).
11	DH-485 Programming Connector	Connects to a Personal Computer Interface Converter (Cat. No. 1747-PIC) for transferring applications. Also connects to an SLC programmer, such as the Hand-Held Terminal (Cat. No. 1747-PT1).
12	RS-232 Communication Port	Connects to the Channel 0 port of an SLC 5/03 or 5/04 controller for point-to-point DH-485 communications. Also connects to the RS-232 serial port of a computer for transferring applications. Channel 0 Port is configured for DH-485 communications using the Advanced Programming Software.
13	Remote I/O Port	Connects to a scanner or sub-scanner on a Remote I/O network.
14	DH+ Communication Port	Connects to a PLC or SLC 5/04 controller on a DH+ link.
15	DeviceNet Connector	Connects to a DeviceNet network.
16	ControlNet Connectors	Connects to a ControlNet network.
17	DF1 Communication Port	Connects to a PLC, SLC or MicroLogix controller with a DF1 port.
18	RS-232 Printer/ File Transfer Port	Connects to a printer. On Remote I/O, DH+, DeviceNet or ControlNet terminals, this port also connects to the RS-232 port of a computer for transferring applications.

PanelView 600 Features

This section defines features of the PanelView 600 terminals.

PanelView 600 Features (Front)

Keypad Terminal

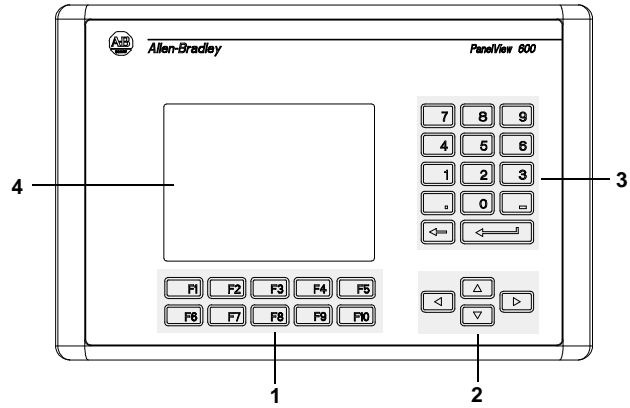

Touch Screen Terminal

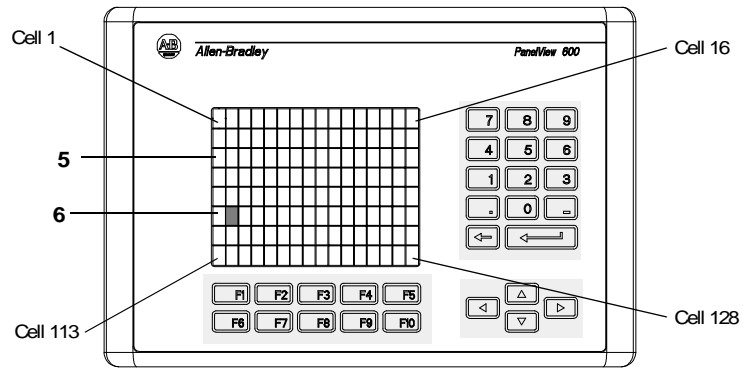

#	Feature	Description
1	Function Keys (F1 - F10)	Use the function keys on keypad terminals to initiate functions on the terminal display. These keys may have custom legends. On the keypad & touch screen terminals, you can initiate functions using the function keys and/or touch screen objects.
2	Cursor Keys	Use the cursor keys to move the cursor in displayed lists, to select a numeric entry object, or to enter configuration mode.
3	Numeric Entry Keys	0-9 Enters numeric values. . Enters a decimal point. - Enters a negative value. ← Clears entered digits or cancels the scratchpad. ↵ Stores an entered value.
4	Keypad Terminal Display	On keypad terminals, initiate the function of a displayed object, such as an ON or OFF push button, by pressing a function key (F1 - F10).
5	Touch Screen Terminal Display	On keypad & touch screen terminals, initiate the function of a displayed object, such as an ON or OFF push button, by touching the screen object. Each interactive screen object occupies one or more of 128 cells. On touch screen & keypad terminals, you can initiate functions, using the function keys and/or touch screen objects.
6	Touch Cells (Touch Screen terminal)	The 128 touch cells (16 columns x 8 rows) let you initiate functions by touching the screen. Interactive screen objects are aligned with touch cells when the application is created.

PanelView 600 Terminal Features (Back)

Remote I/O, DH+, DeviceNet, ControlNet
or DF1 Version with RS-232 Port

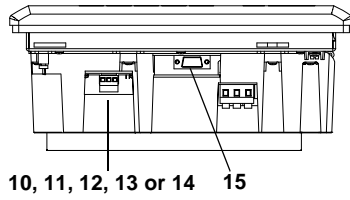

DH-485 Version

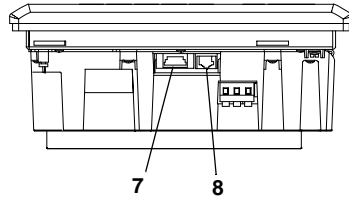

DH-485 Version with RS-232 Port

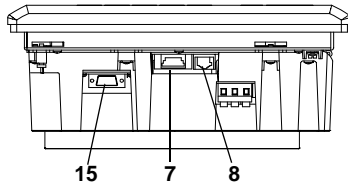

RS-232 Version

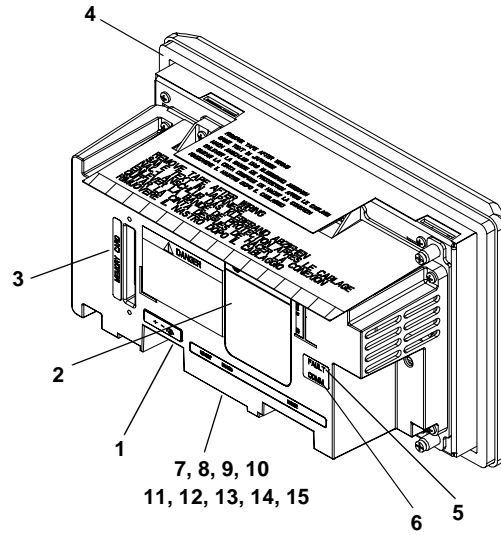
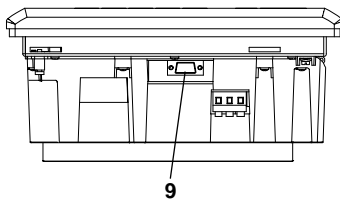

RS-232 Version with additional RS-232 Port

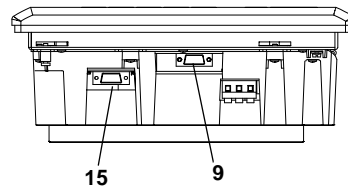

#	Feature	Description
1	Power Connection Terminals	Connects to external power source.
2	Nameplate Label	Provides product information.
3	Memory Card Slot	Accepts a memory card which stores applications.
4	Sealing Gasket	Seals the front of the terminal to an enclosure or panel.
5	FAULT LED (Red)	Indicates firmware or hardware faults.
6	COMM LED (Green)	Indicates when communications is occurring.
7	DH-485 Communication Port	Connects to an SLC controller, DH-485 network, or Wallmount Power Supply (Cat. No. 1747-NP1).
8	DH-485 Programming Connector	Connects to a Personal Computer Interface Converter (Cat. No. 1747-PIC) for transferring applications. Also connects to an SLC programmer, such as the Hand-Held Terminal (Cat. No. 1747-PT1).
9	RS-232 Communication Port	Connects to the Channel 0 port of an SLC 5/03 or 5/04 controller for point-to-point DH-485 communications. Also connects to the RS-232 serial port of a computer for transferring applications. Channel 0 Port is configured for DH-485 communications using the Advanced Programming Software.
10	Remote I/O Port	Connects to a scanner or sub-scanner on a Remote I/O network.
11	DH+ Communication Port	Connects to a PLC or SLC 5/04 controller on a DH+ link.
12	DeviceNet Connector	Connects to a DeviceNet network.
13	ControlNet Connectors	Connects to a ControlNet network.
14	DF1 Communication Port	Connects to a PLC, SLC or MicroLogix controller with a DF1 port.
15	RS-232 Printer/ File Transfer Port	Connects to a printer. On Remote I/O, DH+, DeviceNet or ControlNet terminals, this port also connects to the RS-232 port of a computer for transferring applications.

PanelView 900/1000 Features

This section defines features of the PanelView 900 and 1000 terminals.

PanelView 900/1000 Terminal Features (Front)

Keypad Terminal

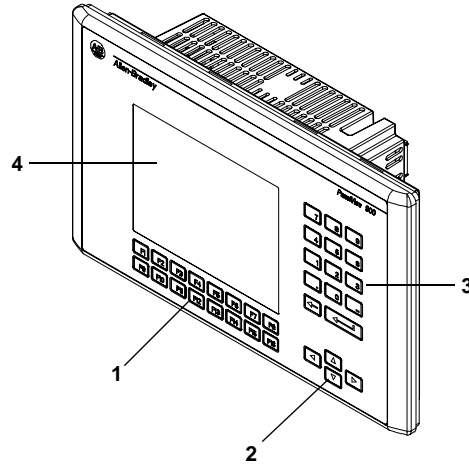

Touch Screen Terminal

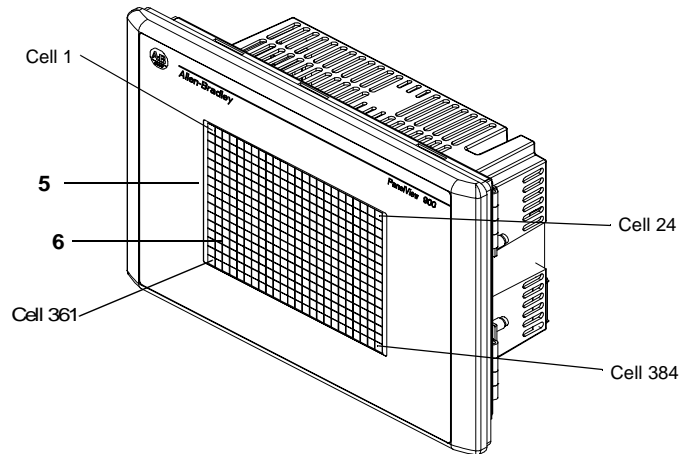

#	Feature	Description
1	Function Keys (F1 - F16)	Use the function keys on keypad terminals to initiate functions on the terminal display. These keys may have custom legends.
2	Cursor Keys	Use the cursor keys to move the cursor in displayed lists, to select a numeric entry object or to enter configuration mode.
3	Numeric Entry Keys	<p>0-9 Enters numeric values.</p> <p>. Enters a decimal point.</p> <p>- Enters a negative value.</p> <p>← Clears entered digits or cancels the scratchpad.</p> <p>↵ Stores an entered value.</p>
4	Keypad Terminal Display	On keypad terminals, initiate the function of a displayed object, such as an ON or OFF push button, by pressing a function key (F1 - F16).
5	Touch Screen Terminal Display	On touch screen terminals, initiate the function of a displayed object, such as an ON or OFF push button, by touching the screen object. Each interactive screen object occupies one or more of 384 cells.
6	Touch Cells (Touch Screen terminal)	The 384 touch cells (24 columns x 16 rows) let you initiate functions by touching the screen. Interactive screen objects are aligned with touch cells when the application is created.

PanelView 900/1000 Terminal Features (Back)

Remote I/O, DH+, DF1, DeviceNet,
or ControlNet Version with RS-232 Port

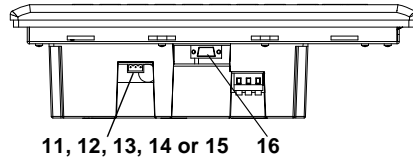

DH-485 Version

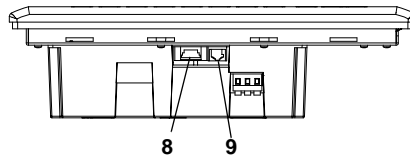

DH-485 Version with RS-232 Port

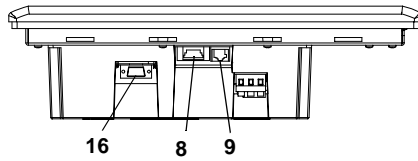

RS-232 Version

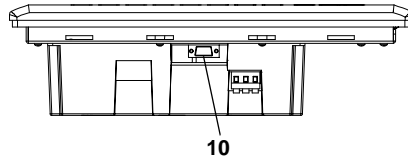

RS-232 Version with additional RS-232 Port

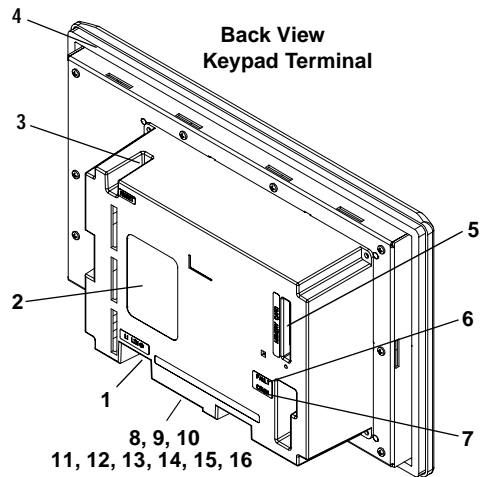
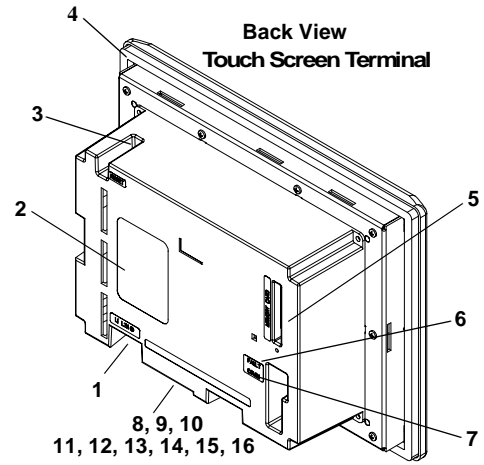
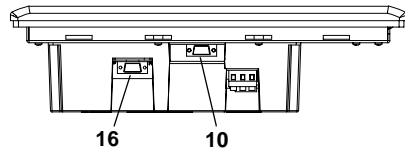

#	Feature	Description
1	Power Connection Terminals	Connects to external power source.
2	Nameplate Label	Provides product information.
3	Reset Button	Resets the terminal.
4	Sealing Gasket	Seals the front of the terminal to an enclosure or panel.
5	Memory Card Slot	Accepts a memory card which stores applications.
6	FAULT LED (Red)	Indicates firmware or hardware faults.
7	COMM LED (Green)	Indicates when communications is occurring.
8	DH-485 Communication Port	Connects to an SLC controller, DH-485 network, or Wallmount Power Supply (Cat. No. 1747-NP1).
9	DH-485 Programming Connector	Connects to a Personal Computer Interface Converter (Cat. No. 1747-PIC) for transferring applications. Also connects to an SLC programmer, such as the Hand-Held Terminal (Cat. No. 1747-PT1).
10	RS-232 Communication Port	Connects to the Channel 0 port of an SLC 5/03 or 5/04 controller for point-to-point DH-485 communications. Also connects to the RS-232 serial port of a computer for transferring applications. Channel 0 Port is configured for DH-485 communications using the Advanced Programming Software.
11	Remote I/O Port	Connects to a scanner or sub-scanner on a Remote I/O network.
12	DH+ Communication Port	Connects to a PLC or SLC 5/04 controller on a DH+ link.
13	DeviceNet Connector	Connects to a DeviceNet network.
14	ControlNet Connectors	Connects to a ControlNet network.
15	DF1 Communication Port	Connects to a PLC, SLC or MicroLogix controller with a DF1 port.
16	RS-232 Printer/ File Transfer Port	Connects to a printer. On Remote I/O, DH+, DeviceNet and ControlNet terminals, this port also connects to the RS-232 port of a computer for transferring applications.

PanelView 1400 Features

This section defines features of the PanelView 1400 terminals.

PanelView 1400 Terminal Features (Front)

Keypad Terminal

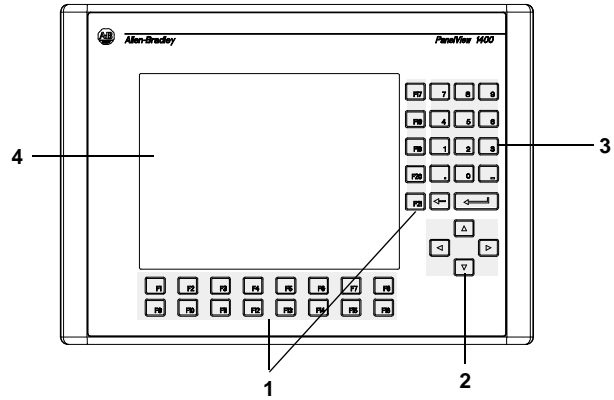

Touch Screen Terminal

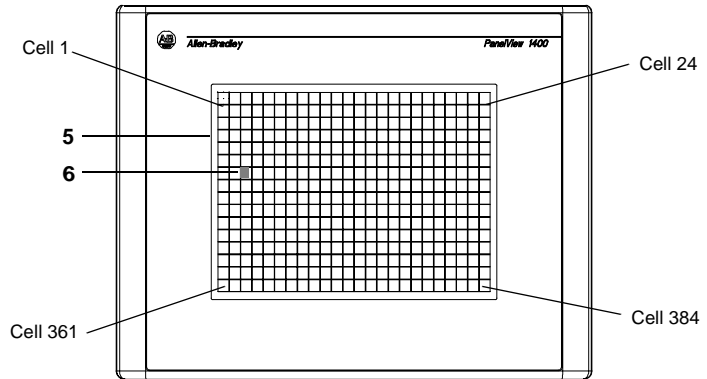

#	Feature	Description
1	Function Keys (F1 - F21)	Use the function keys on keypad terminals to initiate functions on the terminal display. These keys may have custom legends.
2	Cursor Keys	Use the cursor keys to move the cursor in displayed lists, to select a numeric entry object, or to enter configuration mode.
3	Numeric Entry Keys	0-9 Enters numeric values. . Enters a decimal point. - Enters a negative value. ← Clears entered digits or cancels the scratchpad. ↵ Stores an entered value.
4	Keypad Terminal Display	On keypad terminals, initiate the function of a displayed object, such as an ON or OFF push button, by pressing a function key (F1 - F21).
5	Touch Screen Terminal Display	On touch screen terminals, initiate the function of a displayed object, such as an ON or OFF push button, by touching the screen object. Each interactive screen object occupies one or more of 384 cells.
6	Touch Cells (Touch Screen terminal)	The 384 touch cells (24 columns x 16 rows) let you initiate functions by touching the screen. Interactive screen objects are aligned with touch cells when the application is created.

PanelView 1400 Terminal Features (Back and Sides)

Remote I/O, DH+, DeviceNet, ControlNet or DF1 Version with RS-232 Port

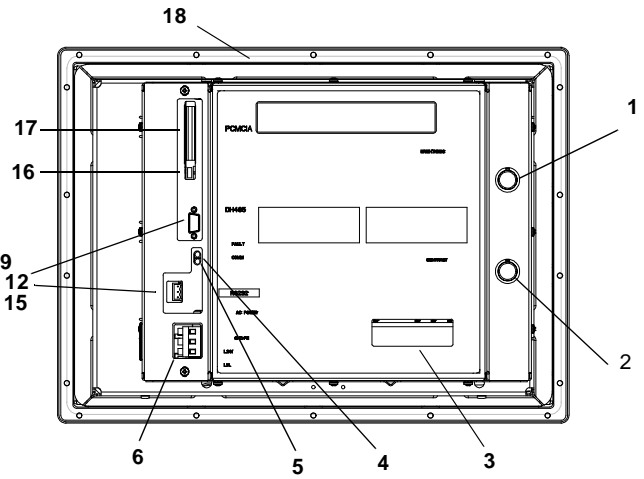
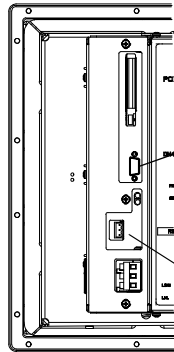

DH-485 Version with RS-232 Port

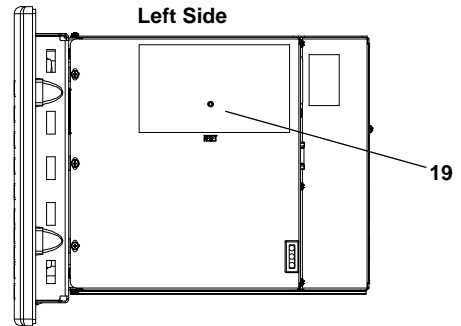
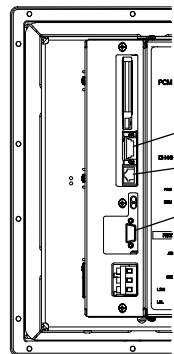

RS-232 Version with additional RS-232 Port

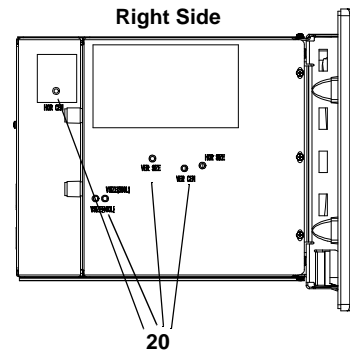
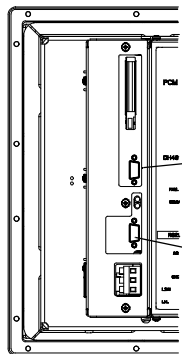

#	Feature	Description
1	Brightness Control	Adjusts the brightness of the color display.
2	Contrast Control	Adjusts the contrast of the color display.
3	Nameplate Label	Provides product information.
4	FAULT LED (Red)	Indicates firmware or hardware faults.
5	COMM LED (Green)	Indicates when communications is occurring.
6	Power Connection Terminals	Connects to external power source.
7	DH-485 Communication Port	Connects to an SLC controller, DH-485 network, or Wallmount Power Supply (Cat. No. 1747-NP1).
8	DH-485 Programming Connector	Connects to a Personal Computer Interface Converter (Cat. No. 1747-PIC) for transferring applications. Also connects to an SLC programmer, such as the Hand-Held Terminal (Cat. No. 1747-PT1).
9	RS-232 Communication Port	Connects to the Channel 0 port of an SLC 5/03 or 5/04 controller for point-to-point DH-485 communications. Also connects to the RS-232 serial port of a computer for transferring applications.
10	Remote I/O Port	Connects to a scanner or sub-scanner on a Remote I/O network.
11	DH+ Communication Port	Connects to a PLC or SLC 5/04 controller on a DH+ link.
12	DeviceNet Connector	Connects to a DeviceNet network.
13	ControlNet Connector	Connects to a ControlNet network.
14	DF1 Communication Port	Connects to a PLC, SLC or MicroLogix controller with a DF1 port.
15	RS-232 Printer/ File Transfer Port	Connects to a printer. On Remote I/O, DH+, DeviceNet or ControlNet terminals, this port also connects to the RS-232 port of a computer for transferring applications.
16	Memory Card Eject Button	Ejects memory card from slot.
17	Memory Card Slot	Accepts a memory card which stores applications.
18	Sealing Gasket	Seals the front of the terminal to an enclosure or panel.
19	Reset Button	Resets the terminal.
20	CRT Board Adjustments	See the warning below.



ATTENTION: Only qualified service technicians should access the CRT board adjustments. Failure to follow this caution could result in electrical shock, a misadjusted monitor, or a damaged monitor.

Applications

PanelView terminals operate with custom designed applications. The first time you power on the terminal, (no application file loaded), the terminal displays the Configuration Mode menu. Chapter 3 describes the terminal functions you can configure from this menu.

Note: Remote I/O terminals provide an out-of-box application for setting Remote I/O communication parameters.

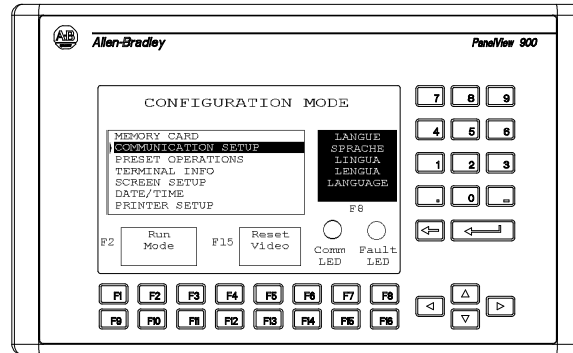

If an application is loaded, the terminal displays the application's start-up screen.

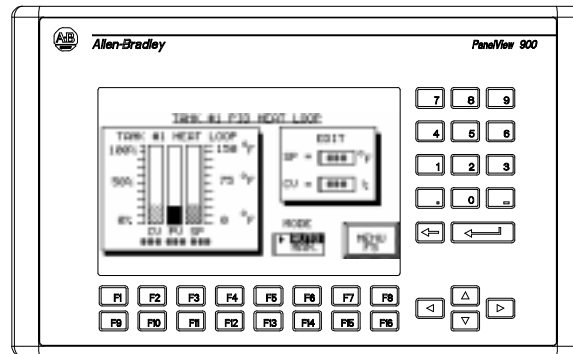

Note: The application designer is responsible for documenting the operation of the application and selecting a startup screen.

How the terminal operates depends on the application and the type of terminal (touch screen or keypad).

Touch Screen Operation

Applications for touch screen terminals are controlled by touching screen objects.

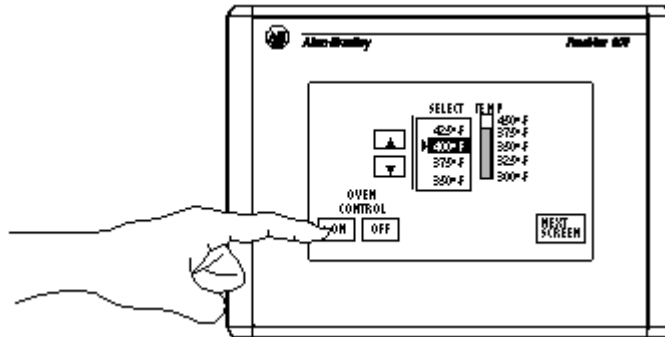

Keypad Operation

Applications for keypad terminals are controlled by pressing function keys that correspond to screen objects. Data is entered manually using the numeric entry keys.

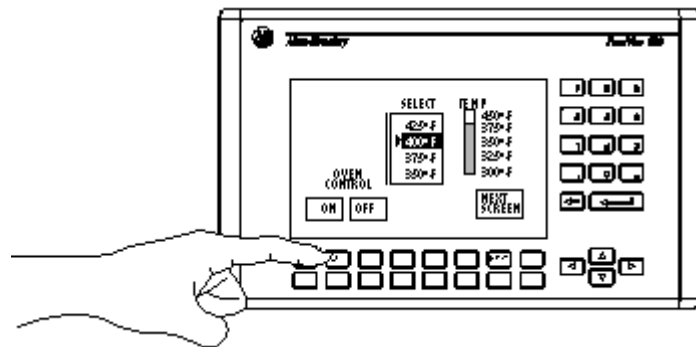

A function key legend kit is available for each terminal to create custom labels for the function keys. See the accessories at the end of this chapter.



ATTENTION: Do not press multiple touch screen objects or multiple function keys at the same time. This may result in unintended operation.

Configuration Mode Menu

You can configure terminal functions from the Configuration Mode menu including:

- select a language
- upload/download applications with a memory card
- set or display serial communication parameters
- select preset values
- obtain terminal and application information
- adjust screen parameters
- set time and date
- set printer parameters (for terminals with an RS-232 printer port)
- return to run mode

Chapter 3 describes how to enter configuration mode and the operations you can perform the Configuration Mode menu.

Terminal Messages

Terminals messages display:

- status of an operation
- minor faults, errors, or numeric entry mistakes
- operator prompts

Appendix B describes terminal messages and provides a list of recommended actions.

Printing

PanelView terminals equipped with an RS-232 printer port can print:

- triggered messages in a message display
- triggered states of a multistate indicator
- alarm messages
- alarm list

Print attributes for objects are defined in the application.

Any printer that supports the IBM enhanced character set can be connected to the RS-232 printer port of a PanelView terminal.

Alarm List

PanelView terminals support an Alarm List queue to store information on triggered alarms. The Alarm List stores a maximum of 100 alarms or as many as the terminal can hold in nonvolatile RAM. The number of alarms stored in the list is configured using the PanelBuilder software.

The Alarm List stores the following data for each alarm:

- acknowledge indicator
- alarm date and time
- acknowledge date and time
- alarm trigger value
- alarm text including variables

The Alarm List is cleared:

- when an application is downloaded to the terminal
- when the terminal is reset or power is cycled

The Alarm List object may appear on the Alarm Banner or other application screens. The data that displays in the Alarm List is configured using the PanelBuilder Software.

Accessories

Software

Catalog No.	550	600	900	1000	1400	Description
2711-ND3	✓	✓	✓	✓	✓	Windows software required for creating Panel-View applications on a personal computer.

Function Key Legend Kits

Catalog No.	550	600	900	1000	1400	Description
2711-NF1	✓					5 legend inserts with key labels F1-F10 on one side. Use blank side to create custom labels.
2711-NF2A			✓			1 legend insert for PV900 keypad (mono-chrome) terminal with key labels F1-F16 on one side. Use blank side to create custom labels.
2711-NF2C			✓			1 legend insert for PV900 keypad (color) terminal with key labels F1-F16 on one side. Use blank side to create custom labels.
2711-NF4		✓				1 legend insert with key labels F1-F10 on one side. Use blank side to create custom labels.
2711-NF5					✓	2 legend inserts. One has key labels F1-F16; the other has key labels F17-F21. Use blank sides to create custom labels.
2711-NF6				✓		1 legend insert with key labels F1-F16. Use blank side to create custom labels.

Memory Cards and Retainer

Catalog No.	550	600	900	1000	1400	Description
2711-NM11	✓	✓	✓	✓	✓	256K memory card for storing applications.
2711-NM12	✓		✓	✓	✓	1M flash memory card for storing applications.
2711-NM13	✓	✓	✓	✓	✓	2M flash memory card for storing applications.
2711-NM14	✓	✓	✓	✓	✓	4M flash memory card for storing applications.
2711-NM22	✓	✓	✓	✓	✓	2M flash ATA card for storing applications and font files.
2711-NM24	✓	✓	✓	✓	✓	4M flash ATA card for storing applications and font files.
2711-NM26	✓	✓	✓	✓	✓	6M flash ATA card for storing applications and font files.
2711-NMCC	✓	✓	✓	✓		Secures memory card in all terminals except the PV1400 and PV550 touch screen. Prevents electrostatic discharge.
2711-NMCD	✓					Secures memory card in 550 touch screen terminal and prevents electrostatic discharge.

Antiglare Overlay

Self-adhesive filters are available to minimize the reflection of terminal displays.

Catalog No.	550	600	900	1000	1400
2711-NV4	✓				
2711-NV4T (Touch Screen Terminals)	✓				
2711-NV3K (Keypad)			✓		
2711-NV3T (Touch Screen Terminals)			✓		
2711-NV5		✓			
2711-NV7K (Keypad Terminals)					✓
2711-NV7T (Touch Screen Terminals)					✓
2711-NV6K (Keypad Terminals)				✓	
2711-NV6T (Touch Screen Terminals)				✓	

DH-485 Operating and Programming Cables

Catalog No.	Description
1747-PIC	Personal Computer Interface Converter converts RS-232 signals to/from RS-485 signals. Use to transfer applications between a DH-485 terminal and a computer.
1747-C10	1.83 meter (6 foot) cable connects a DH-485 terminal to an SLC or DH-485 network.
1747-C11	0.30 meter (1 foot) cable connects a DH-485 terminal to an SLC or DH-485 network.
1747-C20	6.1 meter (20 foot) cable connects a DH-485 terminal to an SLC or DH-485 network.
1747-CP3	45 cm (17.7 inch) cable connects an RS-232 terminal to an AIC+ (Port1) through a null modem adapter.
1761-CBL-AP00	45 cm (17.7 inch) cable connects an RS-232 terminal to an AIC+ (Port2) through a null modem adapter.
1761-CBL-AC00	3 meter (9.8 foot) cable connects an RS-232 terminal to an AIC+ (Port1) through a null modem adapter.
1761-CBL-PM02	2 meter (6.5 foot) cable connects an RS-232 terminal to an AIC+ (Port2) through a null modem adapter.
1761-CBL-AS03	3 meter (9.8 foot) cable connects a DH-485 terminal to an AIC+ (Port3).
1761-CBL-AS09	9.9 meter (29.5 foot) cable connects a DH-485 terminal to an AIC+ (Port3).

PanelView File Transfer Utility

Catalog No.	Description
2711-ND7	Transfers .PVA files between a DH-485 terminal and a computer from the DOS environment. Does not require Windows.

Power Supply and Link Couplers

The following items are available for all DH-485 PanelView terminals.

Catalog No.	Description
1747-NP1	Wallmount Power supply provides power for DH-485 communications when an SLC or network is not connected.
1747-AIC	AIC Link Coupler links devices on a DH-485 network.
1747-NET-AIC	AIC+ Link Coupler links devices on a DH-485 network including MicroLogix.

RS-232 Cables

Catalog No.	Description
2711-NC13	5 meter (16.4 foot) connects an RS-232 terminal to the Channel 0 port of an SLC 5/03 controller or the RS-232 port of a computer or printer.
2711-NC14	10 meter (32.7 foot) cable connects an RS-232 terminal to the Channel 0 port of an SLC 5/03 controller or the RS-232 port of a computer or printer.
2706-NC13	3 meter (10 ft) cable connects an RS-232 terminal to an SLC 5/03 controller or the RS-232 port of a computer or printer.

Remote I/O Cable

Catalog No.	Description
1770-CD	Shielded, 3-conductor cable (Belden 9463) for connecting a Remote I/O terminal to a Remote I/O network.

Replacement Parts**Backlight Lamps**

Catalog No.	550	600	900	1000	Description
2711-NL1	✓				Halogen backlight lamp for all PV550 terminals. Provides backlighting for LCD display.
2711-NL2			✓		Backlight for PV900 color terminal.
2711-NL3		✓			Backlight for PV600 color terminal.
2711-NL4				✓	Backlight for PV1000 color terminal.

Real Time Clock Modules

Catalog No.	550	600	900	1000	1400	Description
2711-NB2	✓					Real time clock module for PV550 (Series D or earlier). Does not apply to the PV550 touch screen terminals. Contains lithium battery.
2711-NB3	✓	✓	✓	✓	✓	Real time clock module for PV600, PV900, PV1000, PV1400 or PV550 (Series E or later). Does not apply to PV550 touch screen terminals. Contains lithium battery.
2711-NB4	✓					Real time clock module for PV550 touch screen only terminals. Contains lithium battery.

Panel Mount Clips and Studs

Catalog No.	550	600	900	1000	1400	Description
2711-NP1					✓	10 panel mount clips for PV1400 terminal.
2711-NP2		✓	✓	✓		6 panel mount clips for PV600, PV900 or PV1000 terminals.
2711-NP3					✓	Optional panel mount studs (18) for PV1400 terminals.

Remote I/O Connector

Catalog No.	550	600	900	1000	1400	Description
22112-046-03	✓	✓	✓	✓	✓	Terminal block connector plugs into Remote I/O port of Remote I/O terminals.

Initial Setup

Chapter Objectives

This chapter provides information on:

- wiring and safety guidelines
- connecting AC or DC power
- resetting the terminal
- power-up sequence

Wiring and Safety Guidelines

Use publication NFPA 70E, Electrical Safety Requirements for Employee Workplaces when wiring the PanelView terminals. In addition to the NFPA general guidelines:

- connect the terminal to its own branch circuit.
The input power should be protected by a fuse or circuit breaker rated at no more than 15 Amps.
- route incoming power to the PanelView terminal by a separate path from the communications cable.



ATTENTION: Do not run signal wiring and power wiring in the same conduit.

- where power and communication lines must cross, they should cross at right angles. Communication lines can be installed in the same conduit as low level DC I/O lines (less than 10 volts).

Connecting AC Power

Below are AC electrical ratings for the PanelView terminals. The PV550 touch screen only terminal is available only with DC power, not AC power.

Terminal Type	Supply Voltage	Power Consumption
PV550	85 to 264V ac, 47 to 63 Hz	45 VA maximum
PV600	85 to 264V ac, 43 to 63 Hz	60 VA maximum
PV900M/PV900C	85 to 264V ac, 47 to 63 Hz	110 VA maximum
PV1000G/PV1000C	85 to 264V ac, 47 to 63 Hz	100 VA maximum
PV1400	85 to 264V ac, 43 to 63 Hz	200 VA maximum



ATTENTION: Do not apply power to the PanelView terminal until all wiring connections have been made. Failure to do so may result in electrical shock.

AC Power Connections

The PanelView terminals are IEC 1131-2 Equipment Class I devices and require you to connect the GND (Ground) or \oplus (Protective Earth) terminal to an earth conductor.



ATTENTION: The PanelView terminals are designed for safe use when installed in a NEMA Type 12, 13, 4X (indoor use only), IP54 or IP65 rated enclosure.



ATTENTION: Explosion Hazard - Do not connect or disconnect equipment while circuit is live unless area is known to be non-hazardous.

To connect power to the AC versions of the PanelView terminals:

1. Secure AC power wires to the L1 and L2N terminal block screws.
2. Secure the Earth Ground/Protective Earth wire to the GND or the \oplus screw on the terminal block.



ATTENTION: Improper wiring of the power terminals may result in voltage at the communication connector shells. Refer to the figure below when wiring.

3. Apply power to the terminal

PanelView 550 Terminal

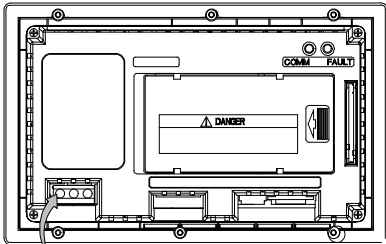

**120/240V ac, 3 Wire,
U.S. Color Code**

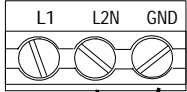

Black (Line)
White (Neutral)
Green (Earth Ground)

To Power Source

**120/240V ac, 3 Wire,
European Harmonized Color Code**

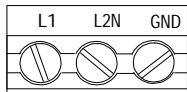

Brown (Line)
Blue (Neutral)
Green/Yellow (Protective Earth)

To Power Source

PanelView 900/1000 Terminal

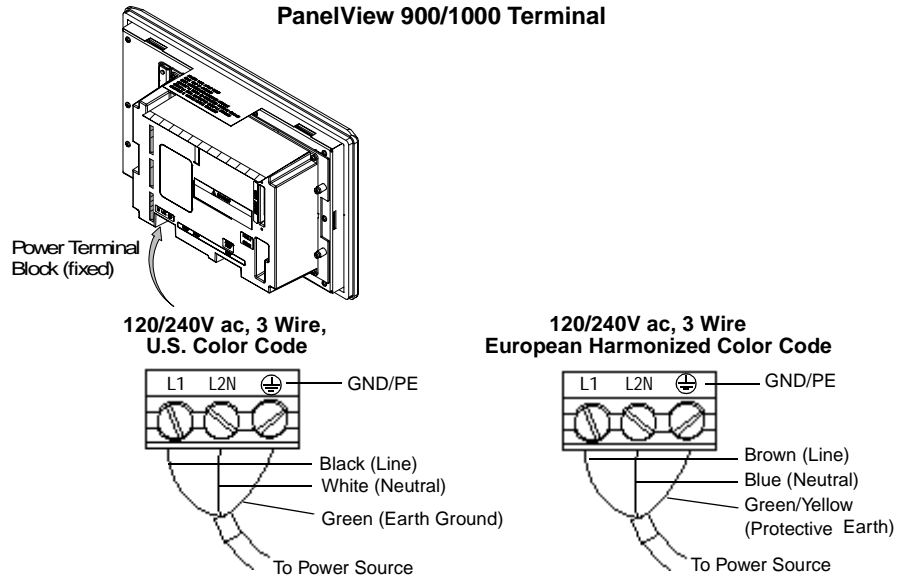

PanelView 1400 Terminal

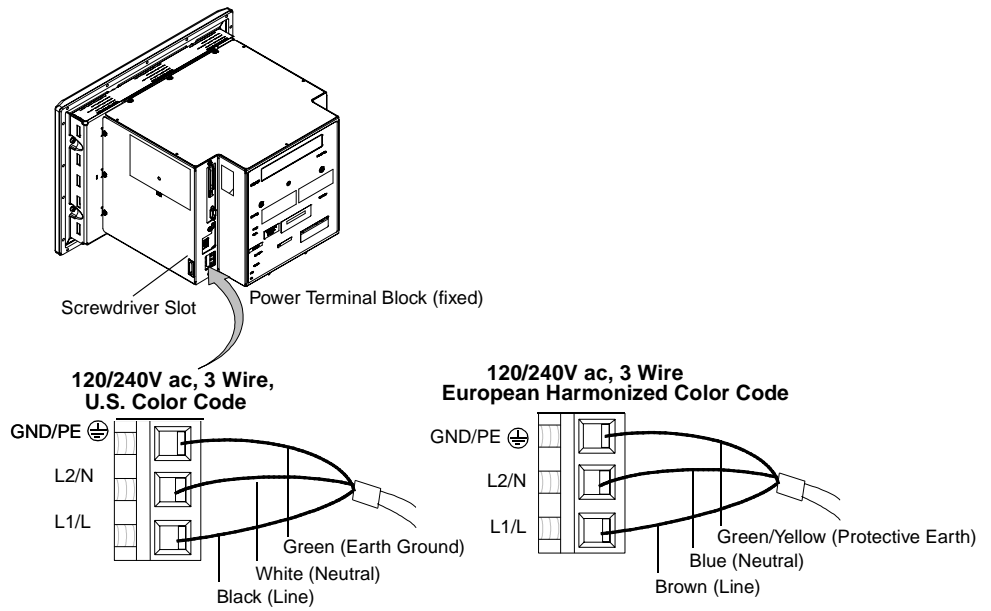

Connecting DC Power

The L1 versions (Cat. No. 2711-K5A1LL1, -T9C1LL1) of the PV550, PV600, PV900, and PV1000 terminals connect to a 24V dc power source.

The table below shows the electrical ratings for the DC versions of the terminals. Electronic circuitry and an internal fuse protect the terminals from reverse polarity and over-voltage conditions

Terminal Type	Supply Voltage (24V dc nominal)	Power Consumption
PV550	18 to 30V dc	18 Watts max. (0.75A @ 24V dc)
PV550 (touch only)	18 to 32V dc	18 Watts max. (0.75A @ 24V dc)
PV600	18 to 32V dc	34 Watts max. (1.4A @ 24V dc)
PV900M	18 to 30V dc	58 Watts max. (2.5A @ 24V dc)
PV900C	18 to 32V dc	50 Watts max. (2.1A @ 24V dc)
PV1000G	18 to 32V dc	40 Watts max. (1.7A @ 24V dc)
PV1000C	18 to 32V dc	50 Watts max. (2.1A @ 24V dc)



ATTENTION: Do not connect the PanelView terminal to an AC power source. Connecting to an AC power source may damage the terminal.



ATTENTION: The PanelView terminals are designed for safe use when installed in a NEMA Type 12, 13, 14X (indoor use only), IP54 or IP65 rated enclosure.



ATTENTION: Use only a safety extra-low voltage (SELV) power supply as a source for the PanelView 550 touch screen terminal. A SELV power supply does not exceed 42.4V dc.

DC Power Connections

Connect the power source to the terminal at the 3-screw terminal block (fixed).

To connect power to the DC versions of the PanelView terminals:

1. Secure the DC power wires to the terminal block screws.
2. Secure the Earth Ground wire to the correct terminal block screw.



ATTENTION: Explosion Hazard - Do not connect or disconnect equipment while circuit is live unless area is known to be non-hazardous.



ATTENTION: Do not apply power to the PanelView terminal until all wiring connections have been made. Failure to do so may result in electrical shock.

3. Apply 24V dc power to the terminal.

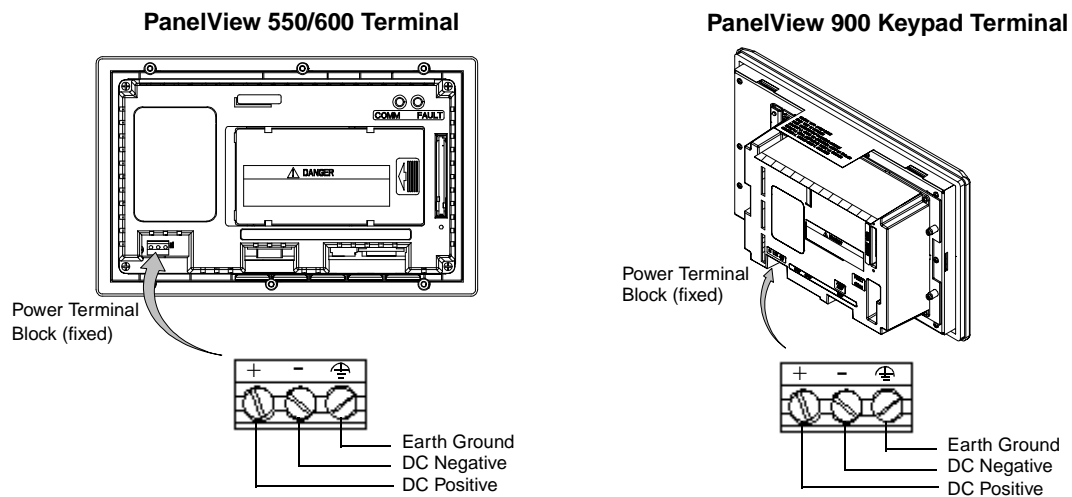

Resetting the Terminal

Resetting the terminal re-initializes the PanelView terminal (same as cycling power).

To reset the PV550 (keypad, keypad & touch screen) and PV600:

Simultaneously press the Left arrow ◀, Right arrow ▶, and Enter ↵ keys. The terminal performs its powerup sequence.

The sequence in which keys are pressed (while running an application), determines what appears after the reset.

- If you press the Left ◀ and Right arrow ▶ keys before the Enter ↵ key, the Configuration Mode menu appears.
- If you press the Enter ↵ key before the arrow keys, the terminal runs the loaded application.

To reset the PV550 (touch screen)/PV900/PV1000/PV1400:

- Use a narrow non-conductive tool to press the reset button shown below. The terminal performs its powerup sequence.



ATTENTION: Use a nonconducting object to press the Reset button. **Do not** use a conducting object such as a paper clip which may damage the terminal. **Do not** use the tip of a pencil, graphite may damage the terminal.

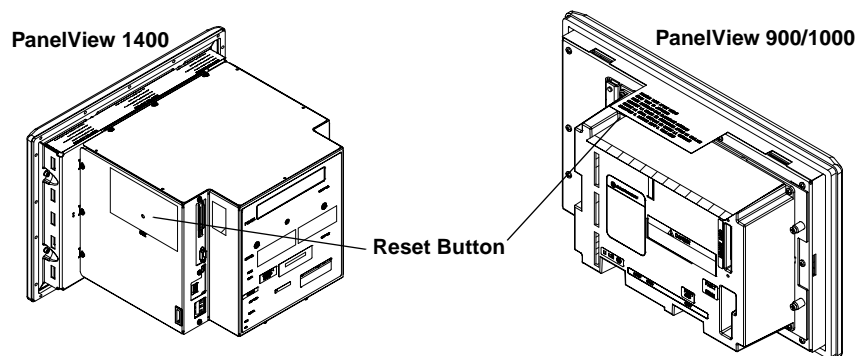

On the PV550 touch screen terminals, the Reset button is located on the right, below the Memory Card slot.

Power-up Sequence

When resetting or applying power to a PanelView terminal, the terminal runs a series of self-tests. The initial display shows copyright information and the status of each self-test number. See Appendix B for a description of the self-test numbers.

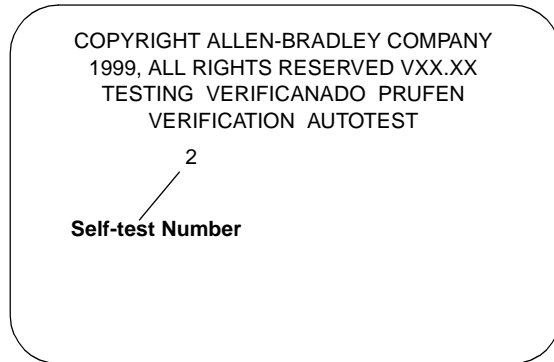

For DH-485 and RS-232 Terminals

- If an application is loaded, the terminal displays either the screen that was present prior to reset or power down, or the startup screen.
- If an application is not loaded, the Configuration Mode menu appears.

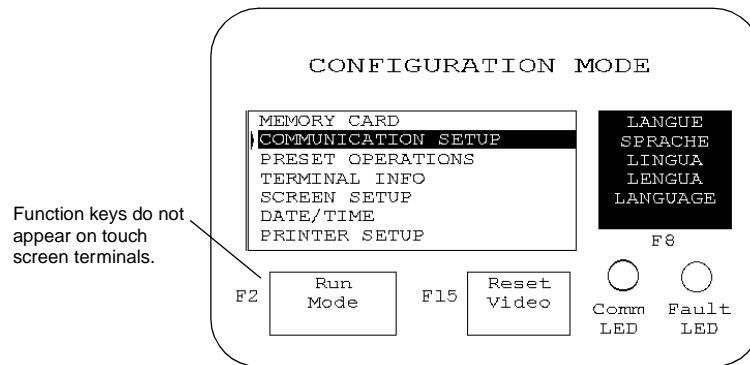

Function keys do not appear on touch screen terminals.

PV900 Keypad Terminal

Note: On PV550/600 terminals, the Reset Video Button is F9.

For Remote I/O Terminals

An out-of-box application screen opens allowing you to set Remote I/O parameters for the terminal. This screen is only available for initial setup. Once an application is downloaded, the Remote I/O setup screen is erased.

The table on the next page defines the Remote I/O Parameters.

Remote I/O Setup

Rack #:	1	Detail	Rack Size:	1/4	F1
Starting Module Group:				0,1	F2
Pass-Through Enabled:				Yes	F3
Last Chassis:				No	F4
Block Transfer Time out:				0	F5
Baud Rate:				57.6K	F6

PV550 Terminal

Remote I/O Setup

Rack # (Detail):	2				F1
	1				
	0				
Rack Size:				1/4	F2
Starting Module Group:				0,1	F3
Pass-Through Enabled:				Yes	F4
Last Chassis:				No	F5
Baud Rate:				57.6K	F6

PanelView 900 Keypad Terminal

Press this function key on:		To set this RIO Parameter	Description	Options
550/600	900/1000/1400			
↵	F1	Rack #	Rack address of terminal on RIO network. On PV550/600: Press ↵ to open the scratchpad. Enter the rack address and press ↵ again. On PV900/PV1000/PV1400: Press F1 to set the rack #, then use the up and down arrow keys to select an address.	0 to 76
F1	F2	Rack Size	Rack size of terminal. Each key press displays a different size. The terminal occupies a single rack.	1/4, 1/2, 3/4, Full
F2	F3	Starting Module Group	Starting module group number of the terminal in the assigned rack. Each key press displays a different module group.	0,1 2,3 4,5 6,7
F3	F4	Pass-Through Enabled	Enables or Disables Pass-Through, which lets you transfer applications between a computer on a DH+ link and a terminal on a Remote I/O link. A PLC-5 controller passes data between the networks.	Yes or No
F4	F5	Last Chassis	Specifies whether the terminal occupies the last module group in the assigned rack (applies only to PLC2 controllers).	Yes or No
F5		Block Transfer Timeout	Timeout value for block transfers. Each key press toggles a value.	0 to 60 seconds (0 is the default)
F6	F6	Baud Rate	Baud rate at which the terminal will communicate on the RIO network.	Baud Max. Cable Length 57.6K 10,000 ft 115.2K 5,000 ft 230.4K 2,500ft

Configuring the Terminal

Chapter Objectives

This chapter tells how to use the Configuration Mode menu to configure terminal settings and perform operations including how to:

- access the Configuration Mode menu
- select a language
- use a memory card
- configure communications (DH485, DH+, Remote I/O, ControlNet, DeviceNet, DF1)
- configure presets
- view terminal information
- set the time and date
- adjust display parameters
- set up the printer

Application Settings

Configuration parameters are set from the terminal or from the PanelBuilder software when creating the application. Settings downloaded with the application have priority over terminal settings if the following option is enabled in the Terminal Setup dialog of the PanelBuilder software.

Use Downloaded configuration settings

In addition, the application may allow the controller to change the following while the application is running:

- time and date
- current display screen
- piloted control lists

Accessing the Configuration Mode Menu

The Configuration Mode menu appears on powerup if an application is not loaded or if the menu was last displayed prior to a reset or power down.

To access Configuration Mode on keypad terminals:

If an application is running, simultaneously press the Left ◀ and Right ▶ arrow keys on the terminal keypad.

To access Configuration Mode on touch screen terminals:

- press the Goto Config. Screen button on an application screen or
- press the filled box in the lower right corner of the screen during powerup.

Note: Most of the screens in this chapter are for the PanelView 900 keypad terminal. The screens for other terminals are similar. On keypad terminals you press terminal function keys to modify settings. On touch screen terminals, you press the screen field or button.

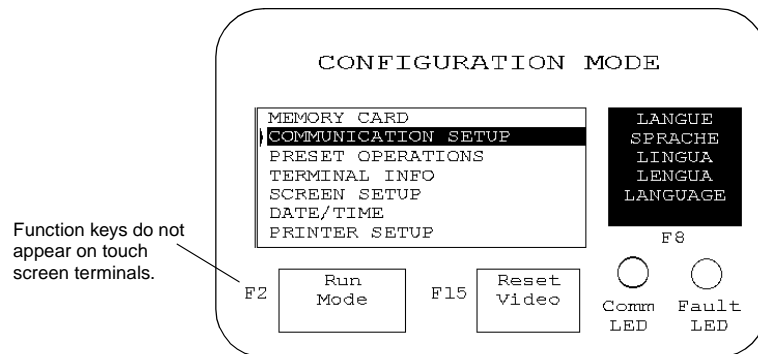

Note: On PV550/PV600 terminals, the Reset Video button is F9.

Operations List

Select an operation using the Up ▲ or Down ▼ arrow keys. Press the Enter ↵ key (keypad terminals) or press  (touch screen terminals) to enter the selection.

Language [F8]

Displays the language menu.

Run Mode [F2]

Runs the loaded application.

Reset Video [F15] or [F9]

Resets the video to default settings. The reset video function is useful if the screen is set to non-viewable settings.

Comm and Fault LED

The 2 LEDs on the Configuration Mode menu indicate the operating state of the terminal. The operating states vary for each communication protocol.

DH-485/DH+ LED Indicators	This pattern	Indicates
Comm	Solid Fill	Normal operating state
	Blinking	No communications
	Flashing	When power is first applied (momentarily)
Fault	No Fill	Normal operating state
	Blinking	Hardware is functioning but no application file is loaded or the current application is corrupt.

Remote I/O LED Indicators	This pattern	Indicates
Comm	Solid Fill	Normal operating state
	No Fill	No communications
	Blinking	PLC controller is in program mode
	Flashing	When power is first applied (momentarily)
Fault	No Fill	Normal operating state
	Blinking	Hardware is functioning but no application file is loaded or the current application is corrupt.

Selecting a Language

Press the Language button, [F8] key, from the Configuration Mode menu to display the Language Selection screen.

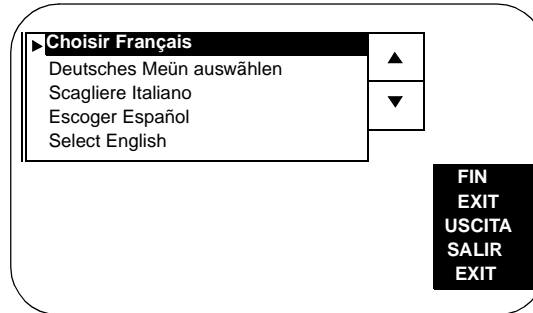

The terminal supports 5 languages:

- French
- German
- Italian
- Spanish
- English

Language List

Select a language using the up or down arrow keys. All configuration screens and terminal messages will be displayed in the selected language.

Exit [F10] or [F16]

Returns to the Configuration Mode menu.

Using a Memory Card

Select Memory Card from the Configuration Mode menu to transfer applications between a memory card and the terminal. Chapter 4 describes the transfer procedure.

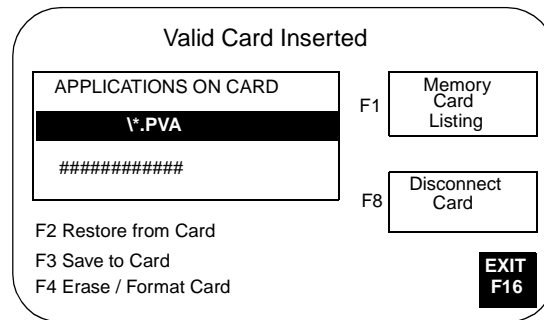

Memory Card Listing [F1]

Displays the file names of applications on the memory card. Only 1 file name is displayed at a time. Press the Memory Card Listing button or [F1] to scroll through the file names. This button does not display the names of font files (*.OTF).

Disconnect Card [F8] or [F5]

Closes all files on the memory card. Press Disconnect before removing the card from the slot to ensure all files are closed. A message appears when you can remove the card from the card slot. Failure to follow this procedure could damage the card.

Applications on Card

Displays the selected application file stored on the memory card.

Restore From Card [F2]

Transfers the application under Applications on Card to the terminal. Any application in the terminal is overwritten.

Save to Card [F3]

Saves the current application in the terminal to the memory card.

Erase/Format Card [F4]

Erases and formats a 2711-NM11, -12, -13, -14 memory card. This function deletes all applications on the card. You can't delete individual files. Don't perform this operation on a 2711-NM22, -24, -26 ATA card or the card will be inoperable.

Exit [F10] or [F16]

Returns to the Configuration Mode menu.

Configuring Communications

Select Communication Setup from the Configuration Mode menu to display or change the communication settings for your PanelView terminal. The screen that appears depends on the communication protocol of the terminal.

DH-485 Communications

The DH-485 screen lets you modify or display DH-485 settings for either a DH-485 or RS-232 PanelView terminal. Default settings are:

- Max Node Address = 31
- Node Address = 2
- Baud Rate = 19200



ATTENTION: Settings downloaded with a DH-485 application take priority over terminal settings and take effect immediately after the download.

DH-485

Max Node:	<input style="width: 80%;" type="text" value="31"/>	F1
Node:	<input style="width: 80%;" type="text" value="2"/>	F2
Baud:	<input style="width: 80%;" type="text" value="19200"/>	F3

Comm
LED

Fault
LED

EXIT
F16

Max Node [F1]

Opens the numeric entry scratchpad. Enter the highest node number on the network (up to 31) and press the Enter ↵ key. (On touch screen terminals, press the ↵ key on the scratchpad). A change to the maximum node address takes effect immediately.

Node [F2]

Opens the numeric entry scratchpad. Enter the node address of the terminal (0 - 31) and press the Enter ↵ key. (On touch screen terminals, press the ↵ key on the scratchpad). If you enter a value greater than the maximum node address, the value is accepted and the maximum node address is updated. A node address change takes effect immediately.

Baud [F3]

Steps through the baud rates with each key press: 1200, 2400, 9600, 19200. The selected baud rate takes effect immediately.

Comm LED

Pattern	Indicates
Solid Fill	Normal operating state
Blinking	No communications established

Fault LED

Pattern	Indicates
No Fill	Normal operating state
Blinking	Hardware is functioning but no application file is loaded or the current application is corrupted.

Exit [F10] or [F16]

Returns to the Configuration Mode menu.

DH+ Communications

The DH+ screen lets you display or modify communication settings for the DH+ version of the PanelView terminals.



ATTENTION: Settings downloaded with a DH+ application take priority over terminal settings and take effect immediately after the download.

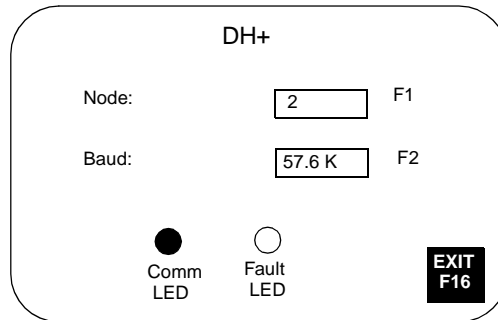

Node [F1]

Opens the numeric entry scratchpad. Enter the node address (0 - 77 octal) of the terminal on the DH+ link and press the Enter ↵ key. (On touch screen terminals, press the Enter key on the scratchpad). A node change takes effect immediately.

Baud [F2]

Steps through the baud rates with each key press: 57.6K (default), 115.2K, 230.4K. The selected rate takes effect immediately. The maximum cable length is restricted at higher baud rates.

Comm LED

- solid fill - normal operating state
- blinking - no communications established
- no fill - hardware failure

Fault LED

- no fill - normal operating state
- blinking - hardware is functioning but an application is not loaded or the current application is corrupted.
- solid fill - hardware failure

Exit [F10] or [F16]

Returns to the Configuration Mode menu.

Remote I/O Communications

The RIO Configuration screen lets you display communication settings for a Remote I/O terminal. Remote I/O settings are configured with the out-of-box application provided with the terminal or from the PanelBuilder software.

The screenshot shows a window titled "RIO Configuration" with the following settings:

Rack Number:	3
Rack Size:	Full
Starting Group:	0,1
Pass-Through Enabled:	Yes
Last Chassis:	Yes
Baud:	115.2K F3

At the bottom of the window, it says "No PLC Communication" and there is a button labeled "EXIT F16".

Settings are **read only**, except for baud rate.

Rack Number (read only)

Displays the current rack number (0 to 76 octal) of the terminal.

Rack Size (read only)

Displays the current rack size (1/4, 1/2, 3/4 or Full) of the terminal.

Starting Group (read only)

Displays the starting module group of the terminal: 0,1 2,3 4,5 6,7

Pass-Through Enabled (read only)

Enables/disables Pass-Through which allows you to transfer applications between a computer on the Allen-Bradley DH+ network and a terminal on the Remote I/O link. A PLC-5 controller passes data between the two networks.

Last Chassis (ready only)

Indicates whether the terminal occupies the last module group in its assigned rack.

Baud [F3]

Steps through the baud rates with each key press: 57.6K (default), 115.2K, 230.4K. The selected rate takes effect immediately. The maximum cable length is restricted at higher baud rates.

Exit [F10] or [F16]

Returns to the Configuration Mode menu.

ControlNet Communications

The ControlNet screen lets you display communications settings for a ControlNet terminal. You are only allowed to change the Node Address and Interscan Delay settings.



ATTENTION: Settings downloaded with a ControlNet application take priority over terminal settings and take effect immediately after the download.

ControlNet

New Node Address F2:	##	Restart Terminal F1
Active Node Address:	03	
Interscan Delay F3:	100	
FW Revision: #####		Serial #: #####
Channel Status	Channel B	EXIT F16
Comms Status	Connected	

New Node Address [F2]

Opens the numeric entry scratchpad. Enter the node address (01 - 99 decimal) of the terminal and press the Enter ↵ key. On touch screen terminals, press the ↵ key on the scratchpad. The initial default is 3. The change takes effect after the terminal is reset. If you enter a value greater than the UMAX node address, the terminal will not go online with the network.

Active Node Address (read only)

Displays the current address of the PanelView terminal.

Interscan Delay [F3]

Opens the numeric entry scratchpad so you can change the Interscan Delay. Enter the delay (100 to 1000 milliseconds in multiples of 100) and press the Enter key. On touch screen terminals, press the ↵ key on the scratchpad. The initial default is 100. A change takes effect immediately.

FW Revision (read only)

Shows the revision # of the firmware in the ControlNet terminal.

Serial Number (read only)

Displays a unique, 32-bit serial number for the PanelView terminal.

Comms Status

Displays the current status of the communication card. *Connected* appears when the PanelView is connected to the network and operating properly.

Channel Status

Displays a value indicating the current status of channel A and B. The definition of each status condition follows the table. If multiple status conditions apply, the highest priority condition is displayed.

Displayed Value	Status A	Status B	Displayed Value	Status A	Status B	Displayed Value	Status A	Status B	Displayed Value	Status A	Status B
119	7	7	87	7	5	55	7	3	23	7	1
118	6	7	86	6	5	54	6	3	22	6	1
117	5	7	85	5	5	53	5	3	21	5	1
116	4	7	84	4	5	52	4	3	20	4	1
115	3	7	83	3	5	51	3	3	19	3	1
114	2	7	82	2	5	50	2	3	18	2	1
113	1	7	81	1	5	49	1	3	17	1	1
112	0	7	80	0	5	48	0	3	16	0	1
103	7	6	71	7	4	39	7	2	7	7	0
102	6	6	70	6	4	38	6	2	6	6	0
101	5	6	69	5	4	37	5	2	5	5	0
100	4	6	68	4	4	36	4	2	4	4	0
99	3	6	67	3	4	35	3	2	3	3	0
98	2	6	66	2	4	34	2	2	2	2	0
97	1	6	65	1	4	33	1	2	1	1	0
96	0	6	64	0	4	32	0	2	0	0	0

Status	Indicates	Priority
7	Terminal failure. Contact Allen-Bradley for technical support.	1 (Highest)
6	Self test being performed. Wait for end of test.	2
5	Incorrect node configuration. Check for duplicate nodes.	3
4	Incorrect network configuration (such as overflow/underflow if signaled by host, out-of-step). Check for a node greater than UMAX.	4
3	Cable fault or lonely connection (such as disconnected cable, redundancy warning).	5
2	Temporary network errors (such as bad MAC frame, screeners not programmed).	6
1	Channel ok.	7
0	Channel disabled.	8 (Lowest)

Restart Terminal [F1]

Resets the PanelView terminal. A new node address takes affect after a reset.

Exit [F10] or [F16]

Returns to the Configuration Mode menu.

DeviceNet Communications

The DeviceNet screen lets you display or modify communication settings for a DeviceNet terminal.



ATTENTION: Settings downloaded with a DeviceNet application take priority over terminal settings and take effect immediately after the download.

DeviceNet

New Node Address F2: Input Size: 0
 Active Node Address: 2 Output Size: 0

New Baud F3:
 Active Baud: 125K

Bus-off Interrupt F4:

Interscan Delay F5: ms

Comms Firmware Revision: Serial Number:

**Restart
Terminal
F1**

Mod/Net LED:
Not Connected

**EXIT
F16**

Restart Terminal [F1]

Resets the terminal.

New Node Address [F2]

Opens the numeric entry scratchpad. Enter the node address (0 - 63) of the PanelView terminal on the DeviceNet link and press the Enter ↵ key. On touch screen terminals, press the ↵ key on the scratchpad. A node change takes effect on reset.

Active Node Address (read only)

Displays the current network operating address of the PanelView terminal.

New Baud [F3]

Step through the baud rates with each key press: 125K (default), 250K, 500K. The selected takes effect immediately. The maximum cable length is restricted at higher baud rates.

Active Baud (read only)

Displays the current baud rate of the PanelView terminal. The baud rate is set to the New Baud value at power-up.

The active baud is the rate of the PanelView, not the network. The PanelView is not automatically set to the network baud rate.

Bus-off Interrupt [F4]

Specifies what occurs when a CAN bus-off interrupt occurs on the DeviceNet network. The PanelView is not allowed network access when Hold on Reset is selected and a Bus-off Interrupt occurs.

- **Hold in Reset** holds the PanelView and waits for a communications reset or a terminal reset.
- **Reset and Continue Communications** resets DeviceNet communications and re-establishes the communications link.

Interscan Delay [F5]

Opens the numeric entry scratchpad so you can change the delay between scans of the Explicit-Client tags. Enter a value of 0 to 65535 milliseconds and press the Enter ↵ key. (On touch screen terminals, press the ↵ key on the scratchpad.) The default is 500 milliseconds.

This time delay is inserted between each full scan of the Explicit-Client tags in the current screen context. The value is initially set by the downloaded application but can be changed by an operator. When changed, the new value takes effect immediately.

Explicit-Client mode will generate low priority, network messaging at intervals less than 500 milliseconds.

Input Size

Displays the number of words (0 to 64) sent by the PanelView in an I/O message. The default value is 0, which indicates that no output data is exchanged with the scanner. This value is set by the downloaded application.

Output Size

Displays the number of words (0 to 64) received by the PanelView in an I/O message. The default value is 0, which indicates no output data is exchanged with the scanner. This value is set by the downloaded application.

Comm LED

- solid fill - normal operating state
- blinking - no communications established
- no fill - hardware failure

Exit [F10] or [F16]

Returns to the Configuration Mode menu.

DF1 Communications

The DF1 screen lets you display or modify DF1/full duplex communication settings for a DF1 PanelView terminal.



ATTENTION: Settings downloaded with a DF1 application have priority over terminal settings and take effect immediately after the download.

DF1 - Full Duplex

<p>Communication Parameters</p> <p>F1</p> <div style="border: 1px solid black; padding: 2px; margin-bottom: 5px;"> No Parity 8 Data Bits 1 Stop Bit </div>	<p>Baud Rate</p> <p>F2</p> <div style="border: 1px solid black; padding: 2px; margin-bottom: 5px; text-align: center;">9600</div> <p>Node</p> <p>F4</p> <div style="border: 1px solid black; padding: 2px; margin-bottom: 5px; text-align: center;">64</div>	<p>Error Detection</p> <p>F3</p> <div style="border: 1px solid black; padding: 2px; margin-bottom: 5px; text-align: center;">CRC</div> <p>Handshaking</p> <p>F5</p> <div style="border: 1px solid black; padding: 2px; margin-bottom: 5px; text-align: center;">OFF</div>
---	--	---

Comm LED

Fault LED

Connected

EXIT
F16

Communication Parameters [F1]

Sets the communication parameters for the DF1 port on the PanelView terminal. The settings must match the target device. Each key press toggles through the available combinations for:

- Parity = None (default), Even or Odd
- Data Bits = 8
- Stop Bits = 1 (default) or 2

The DF1 port on the PLC-5 controllers allows a parity of Even or None parity with 8 Data Bits. For the SLC controllers, the parity is fixed at None and uses CRC error detection.

Baud Rate [F2]

Steps through the baud rates for the DF1 communications port with each key press: 1200, 2400, 4800, 9600, 19200. The initial default is 9600. The baud rate must match the baud rate of the target device.

Error Detection [F3]

Specifies the type of error checking performed on data. The default is CRC (Cyclic Redundancy Check).

- BCC (Block Check Character) - modulo-256 arithmetic sum of an array of data bytes used for medium-level data verification.
- CRC (Cyclic Redundancy Code) - calculated on an array of data bytes and used for high-level data verification.

Node [F4]

Specifies the node number (0 - 254 decimal) for DF1 network communications. For point-to-point communications with an SLC, PLC, MicroLogix or a 1761-NET DNI module, the default node number of 64 is used.

When you press F4, the numeric entry scratchpad opens. Enter a node number and press the Enter ↵ key. (On touch screen terminals, press the ↵ key on the scratchpad.)

Handshaking [F5]

Specifies the type of handshaking used by the RS-232 port.

- On (CTS/RTS enabled)
- OFF (CTS/RTS disabled)

Press F5 or touch the box to select an option. The default is Off.

Comm LED

- solid fill - normal operating state
- blinking - no communications established with logic controller
- no fill - hardware failure

Fault LED

- no fill - normal operating state
- blinking - hardware is functioning but an application is not loaded or the current application is corrupted.

Exit [F10] or [F16]

Returns to the Configuration Mode menu.

Configuring Presets

Select Preset Operations from the Configuration Mode menu to set the values of control objects after a reset or power cycle. You can set presets to:

- values provided by the PanelView application or
- last values entered from terminal prior to a reset or power down.

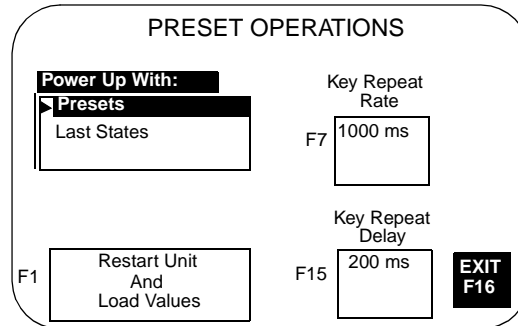

Power-Up with Presets or Last States

Displays the current power-up selection. Use the up ▲ and down ▼ arrow keys on keypad terminals (or the up and down keys on touch screen terminals) to select an option. The selection takes effect the next time the terminal is powered on.

- Select **Presets** to load initial values of control objects (into PLC/SLC data tables) with values supplied by application.
- Select **Last States** to load initial values of control objects (into PLC/SLC data tables) with values entered at the terminal prior to a terminal reset or power down.

Restart Unit and Load Values [F1]

Loads the values selected in the Power-Up With list and resets the terminal.

Key Repeat Rate [F4] or [F7]

Specifies the number of repeats that occur per second when a key is pressed and held. Steps through key repeat rates: 0 (disabled), 200ms (5 times/sec), 250ms (4 times/sec), 330ms (3 times/sec), 500ms (2 times/sec), 1000ms (1 time/sec).

Key Repeat Delay [F9] or [F15]

Specifies how long a key must be pressed before it is repeated. Steps through delay rates: 200ms, 400ms, 600ms, 800ms, 1000ms, 1500ms, 2000ms, 2500ms.

Exit [F10] or [F16]

Returns to the Configuration Mode menu.

Viewing Terminal Information

Select Terminal Info from the Configuration Mode menu to display information about your terminal. This information may be needed when calling for technical support.

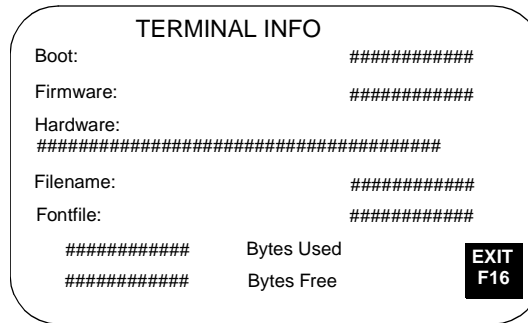

Boot

Displays the boot code revision.

Firmware

Displays the firmware revision.

Hardware

Displays the hardware configuration.

```

Keypad (CPS)
Touch Screen (TS)
Keypad and Touch Screen (TS CPS)
Communications Port (P0.485,P0.232,P1.RIO,P1.DH+,P1.232,P1.DF1)
Screen Size (SS5.5, SS6.0, SS9.0, SS10.0, SS14.0)

```

Filename

Displays the name of the active application file. If the application file exists but is invalid, the file name appears as *****.

- **Bytes Used** displays the number of bytes used by the loaded application.
- **Bytes Free** displays the number of bytes available.

Font File

Displays the name of the external font file used by the application.

Exit [F10] or [F16]

Returns to the Configuration Mode menu.

Adjusting Screen Parameters

Select Screen Setup from the Configuration Mode menu to adjust settings of the terminal display. Changes take effect immediately.

PanelView 550 Screen Setup

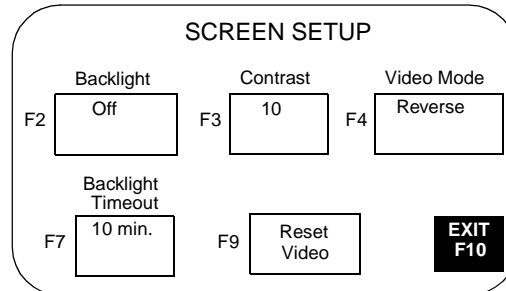

Note: Certain settings may make viewing the screen difficult. Do not exit this screen until viewing adjustments are acceptable.

Backlight [F2]

Turns the backlight On, Off or to Timed mode. When set to Timed, the Backlight Timeout value determines when the backlight is turned off.

Contrast [F3]

Increases or decreases the display contrast. The contrast settings range from 0 to 10.

Video Mode [F4]

Toggles between normal video (dark text/graphics on a light background) and reverse video (light text/graphics on a dark background). Changes take effect immediately.

Backlight Timeout [F7]

Specifies when the backlight turns off if user input or a controller screen change is not received. The timeout settings are 5, 10, 20, 25, or 30 minutes. The Backlight Timeout value is used when the Backlight parameter is set to Timed.

Reset Video [F9]

Resets the display to normal (default settings). The [F9] key is also active on the Configuration Mode menu. If the screen is set to a non-viewable setting, press the Left ◀ and Right ▶ arrow keys simultaneously. Then press [F9] to reset the screen.

Exit [F10] or [F16]

Returns to the Configuration Mode menu.

PanelView 600/900/1000 Color - Screen Setup

The screenshot shows the 'SCREEN SETUP' menu with the following options and values:

- Screen Saver: Off (F1)
- Normal Intensity: 100 (F2)
- Reset Video (F15)
- SCREEN SAVER:
 - Timeout: 10 min. (F9)
 - Intensity: 0 (F10)
- EXIT F16

Note: Certain settings may make viewing the screen difficult. Do not exit this screen until viewing adjustments are acceptable.

Normal Intensity [F2]

Adjusts the intensity of the display with each key press. PV600/1000 settings are 10 - 100, in 10 step increments. PV900 settings are 50 - 100, in 10 step increments.

Screen Saver Mode [F1]

Sets the screen saver to Timed or Off. When Timed, the screen intensity is reduced if user input or a controller screen change is not received within the time specified in the Screen Saver Timeout box.

Screen Saver Timeout [F6] or [F9]

Specifies when an inactive screen enters screen saver mode. The timeout is adjusted in steps with each key press: 5, 10, 15, 20, 25, or 30 minutes.

Screen Saver Intensity [F7] or [F10]

Adjusts the intensity of the display during screen saver mode. PV600/1000 settings are 0 - 100, in 10 step increments. PV900 settings are 0, and 50 - 100, in 10 step increments. It is recommended that you set the intensity to a value less than 100 to prolong the life of the backlight.

Reset Video [F9] or [F15]

Resets the display to normal video (default settings). The [F9] and [F15] keys are active on the Configuration Mode menu. If the screen is non-viewable, press the left ◀ and right ▶ arrow keys simultaneously. Then press [F9] or [F15] to reset the screen.

Exit [F10] or [F16]

Returns to the Configuration Mode menu.

PanelView 900 Monochrome - Screen Setup

SCREEN SETUP		
Normal Intensity 80 F1	SCREEN SAVER Mode Timed F3	SCREENCONDITIONER Mode Disabled F6
Video Mode Normal F2	Timeout 10 min. F4	Hour : Minute ## : 0# F7 F8
Reset Video F15	Intensity 80 F5	EXIT F16

Note: Certain settings may make viewing the screen difficult. Do not exit this screen until viewing adjustments are acceptable.

Normal Intensity [F1]

Adjusts the intensity of the display with each key press: 35, 40, 50, 60, 70, 80, 90, 100. A new setting takes effect immediately.

Video Mode [F2]

Toggles between normal video (light text/graphics on a dark background) and reverse video (dark text/graphics on a light background). The change takes effect immediately. Normal video is recommended.

Screen Saver Mode [F3]

Sets the screen saver to Timed or Off. When Timed, the screen intensity is reduced if user input or a controller screen change is not received within the time specified in the Screen Saver Timeout box.

Screen Saver Timeout [F4]

Specifies when an inactive screen enters screen saver mode. The timeout is adjusted in steps with each key press: 5, 10, 15, 20, 25 or 30 minutes.

Screen Saver Intensity [F5]

Adjusts the intensity of the display during screen saver mode. The intensity is adjusted with each key press: 0, 35, 40, 50, 60, 70, 80, 90, 100

Screen Conditioner Mode [F6]

Enables or disables the screen conditioner. This parameter sets a daily schedule for conditioning the display of a PV900 monochrome terminal to prevent image burn-in.

The conditioning process takes approximately 30 minutes and will not start until the terminal is inactive and in screen saver mode. You can interrupt the screen saver or conditioner at any time by pressing a key or the touch screen. If the screen conditioner is interrupted, it will resume when the screen saver is reactivated.

If you do not use the conditioner, random pixels will illuminate around objects after a period of time (approximately one year).

Screen Conditioner Hour [F7]

Specifies the hour at which to start the screen conditioner. The numeric entry scratchpad opens. Enter a value between 0 - 23, then press the Enter ↵ key (on touch screen terminals, press the Enter key on the scratchpad).

Screen Conditioner Minute [F8]

Specifies the minute at which to start the screen conditioner. The numeric entry scratchpad opens. Enter a value between 0-59, then press the Enter ↵ key (on touch screen terminals, press the Enter key on the scratchpad).

Reset Video [F15]

Resets the display to normal video (default settings).

On keypad terminals, the [F15] key is also active on the Configuration Mode menu. If the screen is non-viewable, press the Left ◀ and Right ▶ arrow keys simultaneously. Then press [F15] to reset the screen.

Exit [F16]

Returns to the Configuration Mode menu.

PanelView 1000 Grayscale -Screen Setup

The screenshot shows a terminal screen with the following layout:

- At the top center, the text "SCREEN SETUP" is displayed.
- Below this, there are three main sections:
 - Screen Saver:** A box containing "Off" with "F1" below it.
 - Video Mode:** A box containing "Normal" with "F2" below it.
 - Reset Video:** A box containing "Reset Video" with "F15" below it.
- Below these, there is a section titled "SCREEN SAVER" in all caps, which contains two sub-sections:
 - Timeout:** A box containing "10 min." with "F9" below it.
 - Intensity:** A box containing "0" with "F10" below it.
- In the bottom right corner, there is a black box with the text "EXIT" and "F16" below it.

Note: Certain settings may make viewing the screen difficult. Do not exit this screen until viewing adjustments are acceptable.

Video Mode [F2]

Toggles between normal video (darker text/graphics on a light background) and reverse video (lighter text/graphics on a dark background). The change takes effect immediately. Normal video is recommended.

Screen Saver Mode [F1]

Sets the screen saver to Timed or Off. When Timed, the screen intensity is reduced if user input or a controller screen change is not received within the time specified in the Screen Saver Timeout box.

Screen Saver Timeout [F9]

Specifies when an inactive screen enters screen saver mode. The timeout is adjusted in 5 minute increments with each key press, from 5 to 30 minutes.

Screen Saver Intensity [F10]

Adjusts the intensity of the display during screen saver mode. Settings are 0 (lowest intensity) or 100 (highest intensity). 0 is recommended to prolong the display life.

Reset Video [F15]

Resets the display to normal video (default settings).

On keypad terminals, the [F15] key is also active on the Configuration Mode menu. If the screen is non-viewable, press the Left ◀ and Right ▶ arrow keys simultaneously. Then press [F15] to reset the screen.

Exit [F16]

Returns to the Configuration Mode menu.

PanelView 1400 Color Setup

SCREEN SETUP

SCREEN SAVER Mode Off F1	DEGAUSS Auto Enabled F4	Normal Intensity 100 F8
Timeout 5 min. F2	Hour Minute ## : 0# F5 F6	Reset Video F15
Intensity 100 F3	Manual Degauss F7	ALIGN TOUCH GRID
		EXIT F16

Touch Screen only

Note: Certain settings may make viewing the screen difficult. Do not exit this screen until viewing adjustments are acceptable.

Screen Saver Mode [F1]

Sets the screen saver to Timed or Off. When Timed, the screen intensity is reduced if user input or a controller screen change is not received within the time specified in the Screen Saver Timeout box.

Screen Saver Timeout [F2]

Specifies when an inactive screen enters screen saver mode. The timeout is adjusted in 5 minute increments with each key press, from 5 to 30 minutes.

Screen Saver Intensity [F3]

Adjusts the intensity of the display during screen saver mode. The intensity is adjusted with each key press: 0, 25, 50, 75, 100.

Degauss Auto [F4]

Enables or disables automatic degaussing. The degauss process takes a few seconds and will not start until the terminal is inactive. Automatic degaussing occurs at midnight unless you adjust the hour and time parameters.

Degauss Hour [F5]

Specifies the hour to start automatic degaussing. The numeric entry scratchpad opens. Enter a value between 0 - 23, then press the Enter ↵ key (on touch screen terminals, press the Enter key on the scratchpad).

Degauss Minute [F6]

Specifies the minute to start automatic degaussing. The numeric entry scratchpad opens. Enter a value between 0 - 59, then press the Enter ↵ key (on touch screen terminals, press the Enter key on the scratchpad).

Manual Degauss [F7]

Allows you to manually degauss the display. When you press [F7], the display is degaussed immediately.

Normal Intensity [F8]

Adjusts the intensity of the display with each key press: 25, 50, 75, 100. The new setting takes effect immediately.

Reset Video [F15]

Resets the display to normal video (default settings).

On keypad terminals, the [F15] key is also active on the Configuration Mode menu. If the screen is non-viewable, press the Left ◀ and Right ▶ arrow keys simultaneously. Then press [F15] to reset the screen.

Align Touch Grid - PV1400 Touch Screen only

Opens the touch alignment screen, which lets you realign the screen with the touch grid. This function is useful when the terminal is positioned at an angle and viewing the screen is difficult unless you realign the screen.

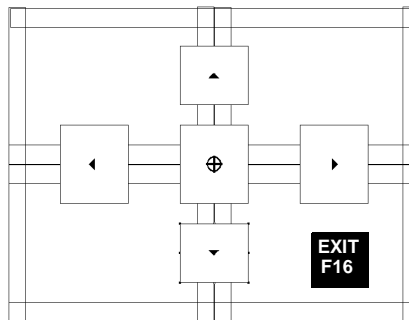

Move the screen until it aligns with the touch cells. Alignment changes are permanent.

Press:	To:
▲	Move the screen up one pixel.
▼	Move the screen down one pixel.
▶	Move the screen to the right 2 pixels.
◀	Move the screen to the left 2 pixels.
⊕	Move the screen to its factory default position.
Exit	Exit the touch alignment screen and return to Screen Setup.

Exit [F16]

Returns to the Configuration Mode menu.

Setting the Time and Date

Select Date/Time from the Configuration Mode menu to reset the data and/or time.

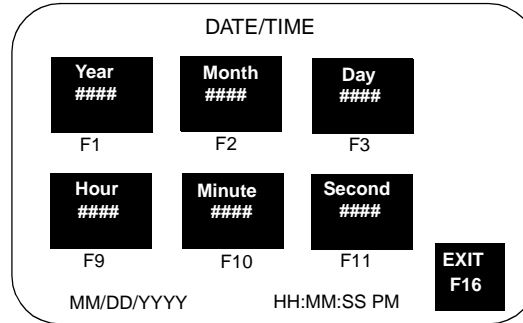

Setting the Time

Use screen buttons (touch screens) or function keys to set the time.

On PV50/PV600 Press:	On PV900/1000/1400 Press:	To:
Hours button [F6] key	Hour button [F9] key	Set current hour
Minute button [F7]	Minute button [F10]	Set minutes
Second button [F8]	Second button [F11]	Set seconds

The scratchpad opens to enter each setting. Use the terminal keypad to enter the values. Press ↵ after each entry. Changes take effect immediately.

Setting the Date

Use screen buttons (touch screens) or function keys to set the date.

Press:	To:
Year button [F1] key	Set current year
Month button [F2]	Set month (1 to 12)
Day button [F3]	Set day (1 to 31)

The scratchpad opens to enter each setting. Use the terminal keypad to enter the values. Press ↵ after each entry. Changes take effect immediately.

Exit [F10] or [F16]

Returns to the Configuration Mode menu.

Setting up the Printer

Select Printer Setup from the Configuration Mode menu to set parameters for those terminals equipped with an RS-232 printer port. Any printer that supports the IBM enhanced character set can be connected to the RS-232 printer port.

PRINTER SETUP		
Handshaking	Communication Parameters	Baud Rate
XON/XOFF F1	No Parity 8 Data Bits 1 Stop Bit F2	19200 F3
Top Of Form F9	Port Mode Printing Enabled F10	EXIT F16

Printer settings are maintained between power cycles.

Page format parameters for printing are defined in the Terminal Setup dialog and downloaded with the application.

Handshaking [F1]

Specifies the type of handshaking used by the RS-232 port.

- None (initial default)
- Hardware
- XON/XOFF

Communication Parameters [F2]

Sets the communication parameters for the printer port. Each key press toggles through the available combinations for:

- Parity (None, Even or Odd)
- Data Bits (7 or 8)
- Stop Bits (1 or 2)

Baud Rate [F3]

Sets the baud rate of the printer port. The baud rate must match the baud rate of the printer. The baud rate is adjusted with each key press: 1200, 2400, 4800, 9600, 19200. The initial default is 9600.

Top of Form [F6] or [F9]

Notifies the PanelView terminal the printer is at the top of a page.

Manually adjust the printer to the top of the page before pressing the Top of Form button. The printer also uses the Perforation Skip Value (if defined in the Printer Setup of the PanelBuilder software) when the Top of Form button is pressed.

On powerup, the terminal assumes the printer is at the top of a page.

Port Mode [F7] or [F10]

Enables or disables printing for the RS-232 port.

The RS-232 port on some terminals supports both printing and application transfers. If you disable printing, the port is used for application transfers.

Exit [F10] or [F16]

Returns to the Configuration Mode menu.

Using a Memory Card

Chapter Objectives

This chapter describes:

- supported memory cards
- using the memory card retainer
- loading application from a memory card
- loading application on a memory card
- storing font files on a memory card
- removing a memory card

Supported Memory Cards

Memory cards are available to transfer application files to/from a PanelView terminal.

PanelView terminals running firmware 3.0 (or later) and computers with an ATA card drive support the following cards:

- 2M flash ATA card (Catalog No. 2711-NM22)
- 4M flash ATA card (Catalog No. 2711-NM24)
- 6M flash ATA card (Catalog No. 2711-NM26)

All PanelView terminals and computers with a DataBook TMB240 or TMB250 card drive support these cards:

- 256K flash memory card (Catalog No. 2711-NM11)
- 1M flash memory card (Catalog No. 2711-NM12)
- 2M flash memory card (Catalog No. 2711-NM13)
- 4M flash memory card (Catalog No. 2711-NM14)

Using the Memory Card Retainer

A Memory Card Retainer (Catalog No. 2711-NMCC or -NMCD) is shipped with all PanelView terminals, except the PV1400. It is required for:

- UL508 installations
- vibration/mechanical shock environments
- CE certified installations
- installations where the application uses a font file on a memory card, and the card must remain in the terminal during operation.

The following illustration shows the memory card and the memory card retainer. The card loads in the back of the terminal with the key slot on top.

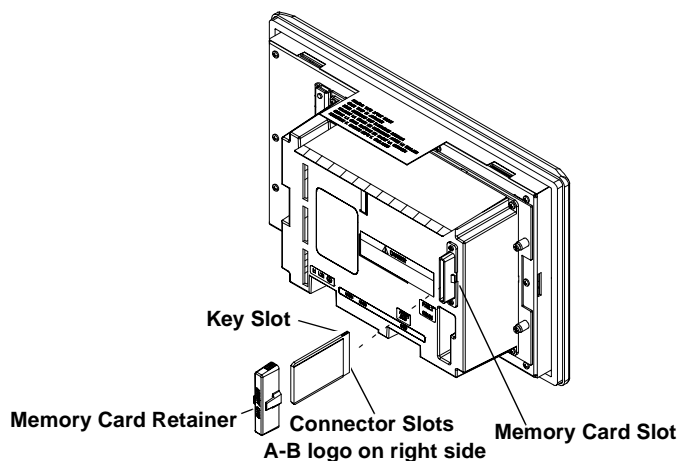

Note: The back of the PanelView 900 terminal is shown above. The location of the card slot will vary between the different terminals.

The Memory Card Retainer protects against:

- electrical shock from loose high voltage wires in an electrical enclosure per UL508



ATTENTION: When permanently installing a memory card in an electrical enclosure, the memory card retainer must be used to avoid accidental contact of high voltage leads to metal surfaces on the card. Failure to use the retainer could result in physical injury or damage to the terminal.

-
- electrostatic discharge (ESD) up to 15KV



ATTENTION: Without the memory card retainer installed, electrostatic discharge could reset or damage the PanelView terminal.

-
- accidental removal or ejection of the memory card from the card slot.



ATTENTION: Accidental removal of an ATA flash card from the card slot could result in damage to the card.

Loading Application from a Memory Card

The procedure below shows how to load an application on a memory card into the PanelView terminal.



ATTENTION: Explosion Hazard - Do not install or remove memory card unless power has been switched off or the area is known to be non-hazardous.

To load an application from a memory card:

1. Insert the memory card in the card slot of the terminal.
If the terminal does not have an application loaded, the Configuration Mode menu appears. Skip step 2.
2. Open the Configuration Mode menu by simultaneously pressing the Left ◀ and Right ▶ arrows (on keypad terminals), or the Goto Config. Screen button (on touch screen terminals).

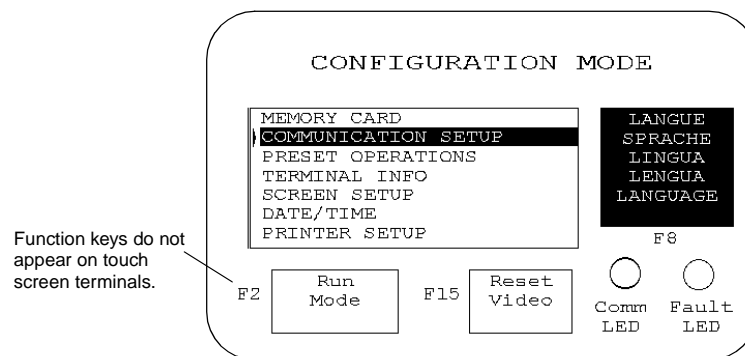

3. Select Memory Card and press the Enter ↵ key.

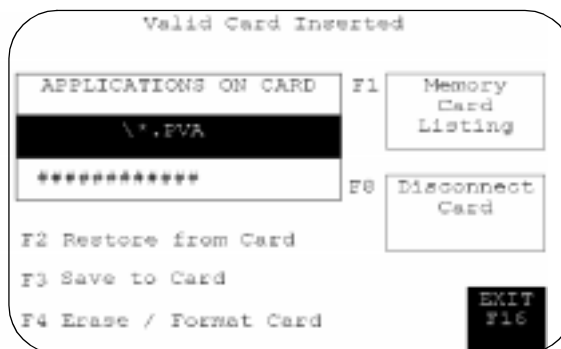

4. Press Memory Card Listing, [F1] on keypad terminals, until the application file you want to load is displayed.

5. Press Restore From Card, [F2] on keypad terminals, to begin the transfer.

Because this operation overwrites the current application in the terminal, you are prompted to abort or continue.

Proceed with download?

F1 - Abort

F2 - Continue

The terminal displays the status of the transfer.

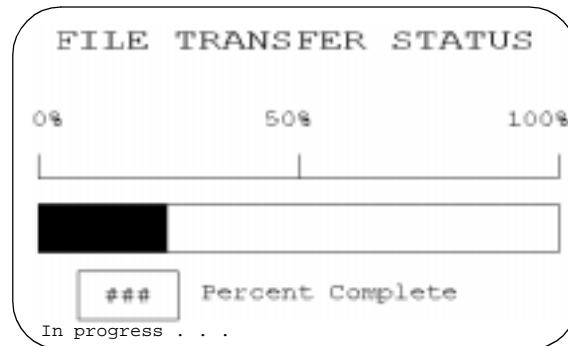

6. When the transfer is complete, the PanelView terminal checks the validity of the application, resets and runs the application.

Loading Application on a Memory Card

The steps below shows how to load an application in the terminal onto a memory card.



ATTENTION: Explosion Hazard - Do not install or remove memory card unless power has been switched off or the area is known to be non-hazardous.

To transfer an application to a memory card:

1. Insert the memory card into the card slot of the terminal.
2. Open the Configuration Mode menu by simultaneously pressing the Left ◀ and Right ▶ arrows (on keypad terminals), or the Goto Config. Screen button (on touch screen terminals).

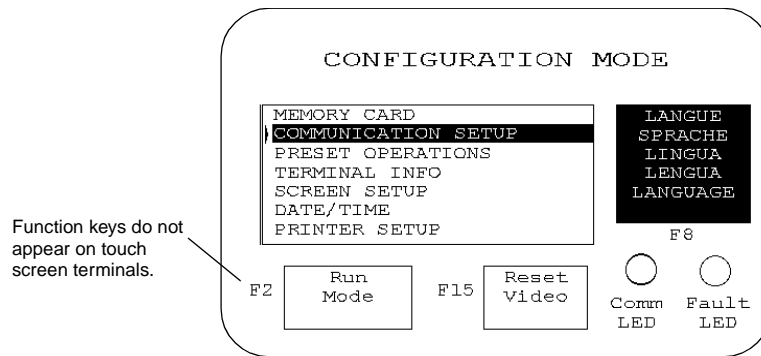

3. Select Memory Card and press the Enter ↵ key.

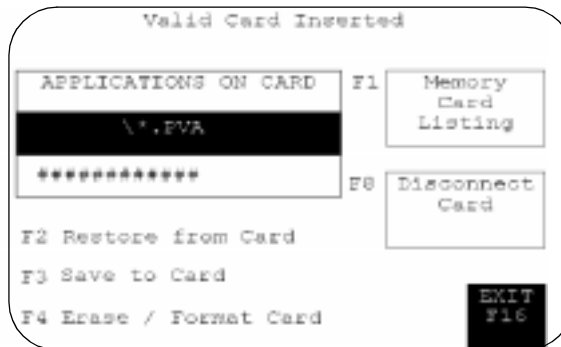

4. If necessary, press Erase/Format Card, [F4] key on keypad terminals, to format or erase a 2711-NM11, -12, -13, -14 memory card. Do not perform this operation on a 2711-NM22, -24, -26 ATA card. The card becomes inoperable.

Because this operation erases all data on the memory card, you are prompted to abort or continue.

Format erases entire card?

- F1 - Abort
- F2 - Continue

5. Press Save to Card, [F3] on keypad terminals, to transfer the application in the terminal to the card.

If the application already exists on the memory card, you are prompted to abort or continue.

The .PVA file exits:

F1 - Abort

F2 - Upload with new PVA file

The terminal displays the status of the transfer.

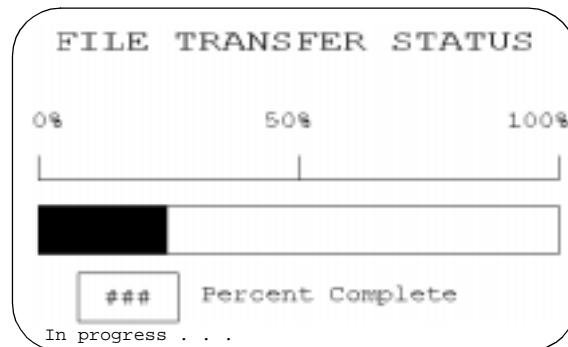

6. When the transfer is complete, the application file name appears in the Applications on Card list. Press Memory Card Listing, [F1] key on keypad terminals, to scroll through the list.

Note: If you upload a file that exists on the memory card, the uploaded file name is altered with a sequential digit as a suffix. For example, Control.pva becomes Control0.pva.

For files with eight character names, a digit overwrites the last character. For example, Motorcon.pva becomes Motorco0.pva.

Storing Font Files on a Memory Card

Memory cards also store font files for languages used by PanelView applications. The font file contains the character set for the language.

The memory card containing the font file must be inserted in the PanelView terminal while the application is running. The terminal uses the font file to display characters on the application screen.

To view the name of the font file used by an application, select Terminal Info from the Configuration Mode menu.

Because the memory card must remain in the terminal while the application is running, it is recommended that you use the Memory Card Retainer (Cat. No. 2711-NMCC, -NMCD) to secure the card in the card slot. The retainer ensures the card is not accidentally removed or dislodged during terminal operation.

Removing a Memory Card

Follow the procedure below to remove a memory card from the PanelView terminal. Failure to follow this procedure may result in damage to the card.

1. Select Memory Card from the Configuration Mode menu.
2. Press the Disconnect Card button. This ensures that all files are closed on the card.

A message prompts you to remove the card from the slot. You can continue or abort the operation.

3. Press the Continue button.
4. Remove the memory card from the card slot.

On PV1400 terminals, press the Memory Card Eject button.

Running Applications

Chapter Objectives

This chapter describes operating procedures common to most applications:

- push button operation
- control lists
- numeric entry controls
- screen selectors
- list indicators
- multistate indicators
- bar graphs
- numeric data displays
- message displays
- time or date
- printing
- alarms

Application Information

The application designer is responsible for documenting the operation of an application. Before running the application, you should understand what processes are being controlled and monitored.



ATTENTION: Do not press multiple touch screen objects at the same time. Pressing multiple objects simultaneously may result unintended operation.

Push Button Operation

Screen push buttons function like mechanical push buttons.

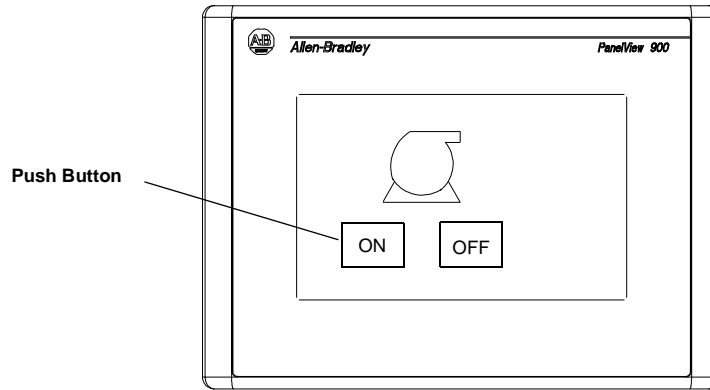

Push buttons have a variety of appearances. Push buttons may change their inner text, fill pattern, border or shape when pressed (each state assigned different attributes).

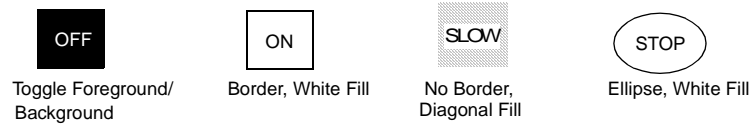

The following are common to most push buttons:

- All push buttons are momentarily disabled (0.5 second) after a screen change. This prevents multiple buttons, in the same location on different screens, from being pressed inadvertently.
- All push buttons must be released on the previous screen before buttons can be pressed on the new screen.
- Momentary push buttons are assigned a hold time. The hold time maintains the pressed state so that each change of state can be read by the controller at least once. The hold time varies between 0 and 1 second depending on the configured setting.

Control Lists

Control lists perform functions similar to push buttons. They can modify either individual bits or values at a controller address.

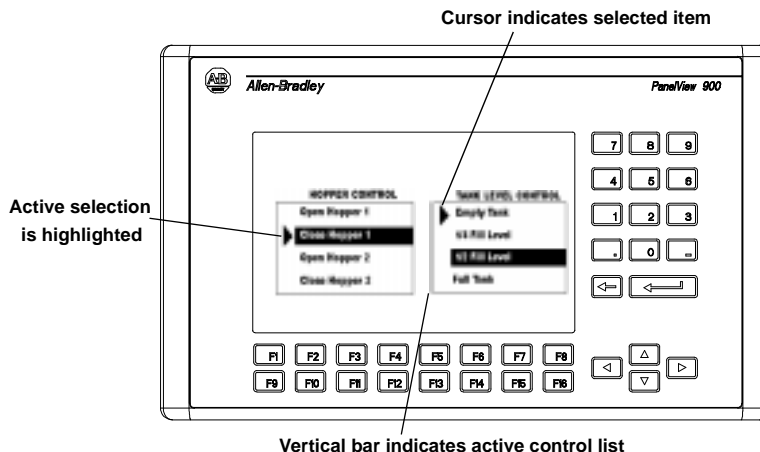

Active List Item

Active item is highlighted.

Active Control List

Has a vertical indicator bar on the left side of the list. Only one control list or numeric entry cursor point can be active on a screen.

To activate a control list:

- touch the object (touch screen terminals only)
- or press the assigned function key
- or on a screen with multiple control lists or numeric entry cursor points, press the Left ◀ or Right ▶ arrows to move the indicator bar between the objects.

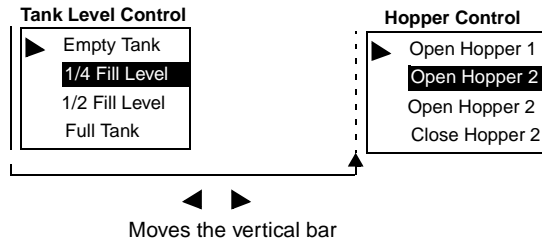

Cursor

Indicates the selected item. Move the cursor up or down the control list using the Up ▼ and Down ▲ arrow keys. Cursor operation is configured by the application designer. If the cursor is at the first or last item in a control list pressing the Up arrow (when at the top) or the Down arrow (when at the bottom) will either:

- cause no movement of the cursor, or
- move the cursor to the top or bottom of the list.

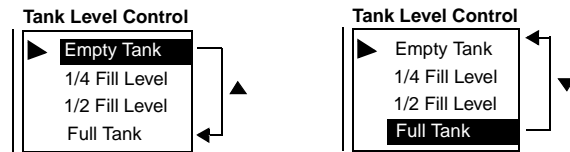

If the list contains more items than can appear at one time, the list scrolls. If the cursor is at the top or bottom of a scrolling list, the list scrolls one row at a time as the arrow keys are pressed.

List Keys

Touch screen terminals require list keys on the screen to move the cursor in a control list and select entries. The following table shows the list keys.

List Key	Type	Description
	Move Up	Moves the cursor to the previous item in the list.
	Move Down	Moves the cursor to the next item in the list.
	Home	Moves the cursor to the first item in the list.
	End	Moves the cursor to the last item in the list.
	Page Up	Moves the cursor up one page in a scrolling list.
	Page Down	Moves the cursor down one page in a scrolling list.
	Backspace	Returns the cursor to the currently highlighted selection.
	Enter	Confirms a selection and sends the value to the controller if Write on Enter was configured for the control list.

Cursor - Piloted Control Lists

On a piloted control list, some items are under controller operation only. In addition, some items may be designated as inactive. You cannot select controller items or inactive items. In both cases, the cursor is hollow when you select the item.

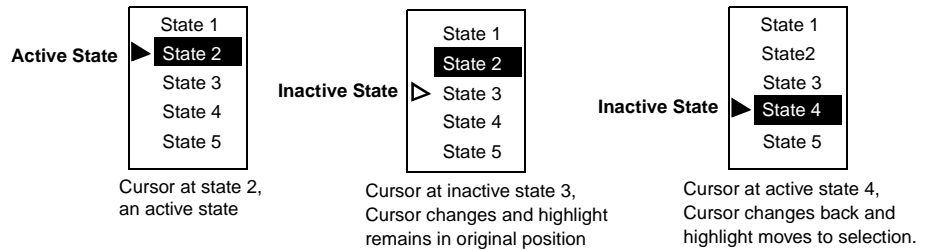

To select an item on a control list:

1. Select the control list by:
 - touching the screen object (touch screen terminals only)
 - or pressing its function key
 - or pressing the Left ◀ or Right ▶ arrow keys until the control list has a vertical bar indicating it is active
2. Move the cursor up or down the list using the Up ▲ or Down ▼ arrows. If the cursor is hollow, the item cannot be selected.
3. Depending on the application design, you may or may not have to press ↵ to enter the selection indicated by the cursor.

Numeric Entry Controls

Two types of controls allow a numeric value at a controller address: Cursor Point and Keypad Enable button.

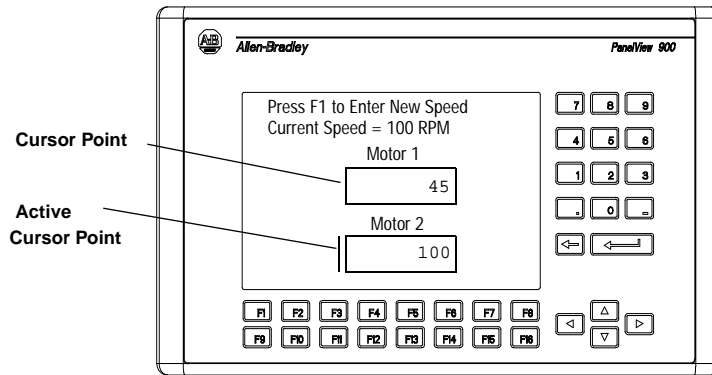

Numeric Entry Cursor Point

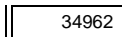

A keypad enable button appears like a standard push button. The data displayed in the button is the last value sent to the button's tag address. When selected, a numeric entry scratchpad opens.

Keypad Enable Button



A keypad enable button appears like a standard push button. The data displayed in the button is the last value sent to the button's tag address. When selected, a numeric entry scratchpad opens.

Scratchpad

Both controls display a numeric entry scratchpad in the center of the screen. The scratchpad shows the current value entered and the range of possible values you can enter.

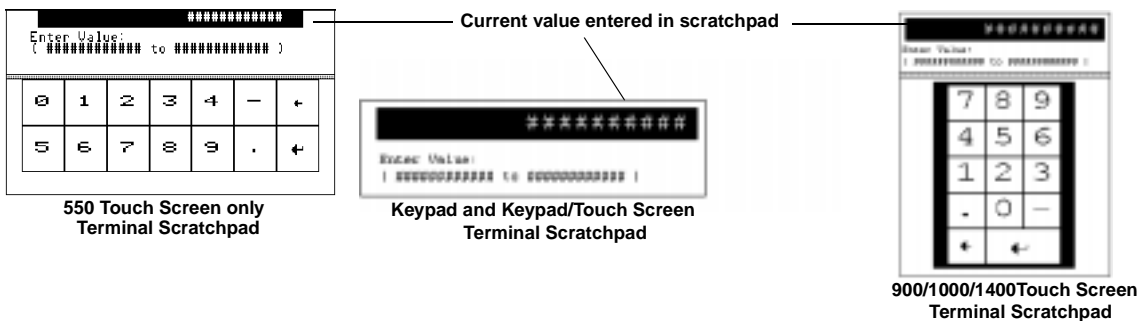

During data entry, wait until the number you enter appears in the scratchpad before entering the next number.

To enter a cursor point:

1. Select the cursor point by:
 - touching the object (touch screen terminal only)
 - pressing the associated function key
 - press the Left ◀ or Right ▶ arrows until the cursor point shows a vertical bar
2. Press Enter ↵ or type the first digit of the number you want to enter.
The scratchpad opens.
3. Enter the value using the terminal keypad and press Enter ↵.

To enter a value using the keypad enable button:

1. Press the keypad enable button.
The scratchpad opens.
2. Enter the value using the terminal keypad and press Enter ↵.

To change an entry on a scratchpad:

1. Press the backspace ← key to delete one character at a time.
2. Enter a new value and press Enter ↵.

To cancel a scratchpad:

1. Press the Backspace ← key to delete one character at a time.
2. When pressing Backspace ← in an empty scratchpad (value = 0), the scratchpad is removed.

Screen Selectors

The 2 types of screen selector controls are Screen List Selectors and Screen buttons.

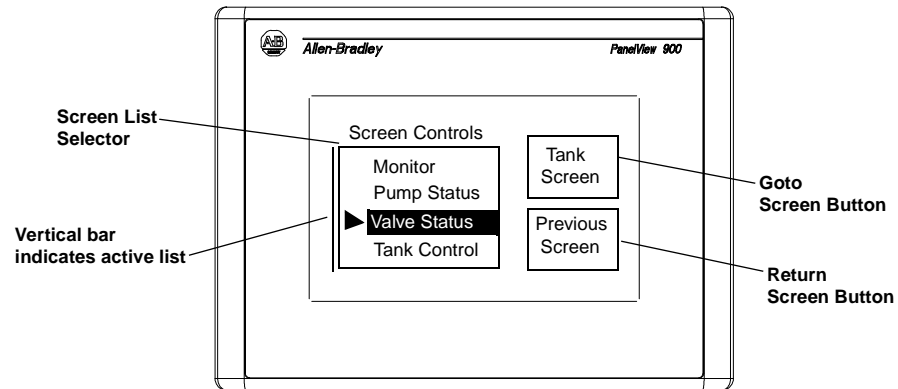

Goto and Return screen buttons can have a variety of appearances such as unique inner text, fill pattern, border or shape. Return screen buttons display the previous screen. Goto screen buttons display the assigned screen.

Screen lists display a list of application screens. The selected screen is highlighted.

To activate a screen list:

- touch the object (touch screen only)
- or press the assigned function key
- or on a screen with multiple screen lists, press the Left ◀ or Right ▶ arrow key until a vertical bar appears.

To select an item on a screen list:

1. Move the cursor up or down the list using the Up ▲ or Down ▼ arrow keys.
2. Press Enter ↵ to enter the selection.
The selected screen is displayed.

Cursor Operation

Cursor operation is configured by the application designer. If the cursor is at the first or last item in a screen list, pressing the Up ▲ arrow (when at top) or Down ▼ arrow (when at bottom) will either:

- cause no movement of the cursor, or
- move the cursor to the top or bottom of the list

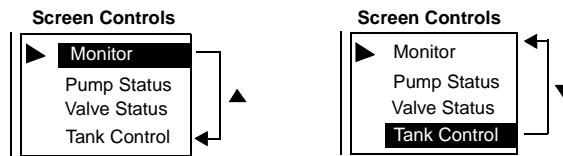

If a screen list contains more items than can appear at one time, the list scrolls. If the cursor is at the top or bottom of a scrolling list, the list scrolls one row at a time as the Up/Down arrows are pressed.

List Keys

Touch screen terminals require list keys on the screen to move the cursor in a screen list and select an entry. The following table shows the list keys.

List Key	Type	Description
	Move Up	Moves the cursor to the previous item in the list.
	Move Down	Moves the cursor to the next item in the list.
	Home	Moves the cursor to the first item in the list.
	End	Moves the cursor to the last item in the list.
	Page Up	Moves the cursor up one page in a scrolling list.
	Page Down	Moves the cursor down one page in a scrolling list.
	Backspace	Returns the cursor to the currently highlighted selection.
	Enter	Confirms a selection and displays the screen.

List Indicators

List indicators highlight an item from a list depending upon the status of either a bit or value at a controller address.

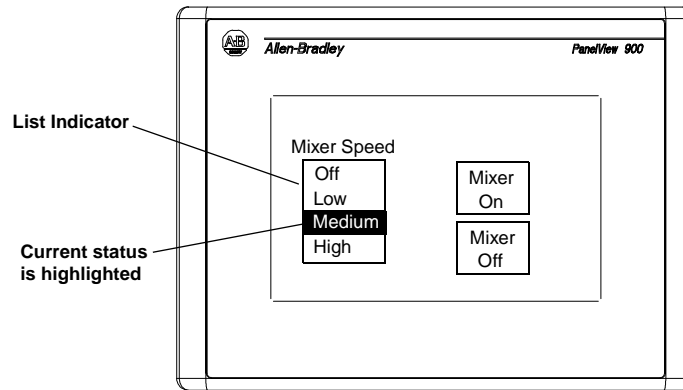

An indicator list may have a maximum of 255 entries. The list automatically scrolls to display the status of an item.

Note: List indicators do not have a cursor ► like control or screen selector lists.

Multistate Indicators

Multistate indicators display the status of either a bit or value at a controller address.

Multistate indicators can have a variety of appearances. In addition, multistate indicators may change their inner text, fill pattern, or graphic with each state (each state assigned different attributes). Each indicator may have up to 2,000 states.

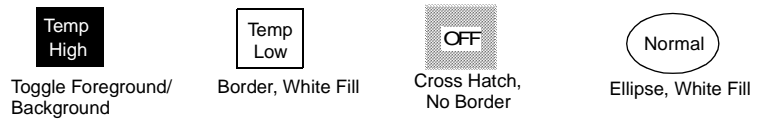

Bar Graph Displays

Bar graphs provide a graphical representation of a variable value. Bar graphs can appear with or without scales and border, and can have a variety of fill patterns.

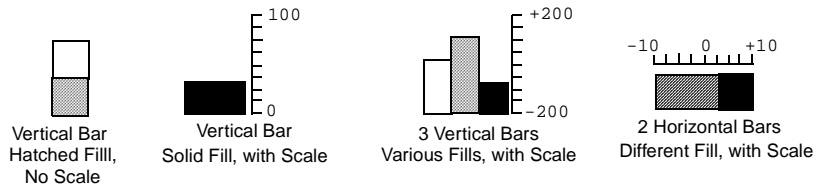

Numeric Data Displays

Numeric Data Displays may appear with or without supporting text.

Flow= 37 Gallons

0 0 0 2 3 9 . 4 5

Depending on the application design, displayed data may have these properties:

- zero fill
- fixed, floating or no decimal point
- different field widths (number of digits)
- various text sizes
- scaled

Message Displays

Message displays contain alphanumeric characters and are displayed when triggered by a controller. The message display can be any size and will not overlap other controls. Messages may contain:

- alphanumeric text
- variable data
- graphics
- time and date

Time or Date

Time and date information can appear as a separate item or in some control/display objects (push buttons, multistate indicators, message displays or data displays). A time and date can appear with or without supporting text.

The date can have a variety of formats.

Month/Day/Year 7/3/99	With Leading Zeroes 07/03/99
Day/Month/Year 3/7/99	With 4 Digit Year 3/7/99
Year/Month/Day 99/7/3	With User-Defined Separator 7*3*99

The time can also have a variety of formats.

12 Hour Format 2:56	With Time Zone & Time Standard Designations 07/03/97
24 Hour Format 14:56	With Leading Zeroes 02:56
with Seconds 14:56:29	With User-Defined Separator 14*56*29

Printing

Terminals equipped with an RS-232 printer port can print:

- triggered messages in a message display
- triggered states of a multistate indicator
- alarm messages
- alarm history

Text is printed without formatting options. Print attributes for objects and alarms are defined in the application.

Printing is a background operation. While printing, the terminal continues to update and you can perform other terminal operations.

The terminal prints messages in the order they are received. If the print buffer is full, the terminal displays a queue full warning message. New print requests are aborted.

The print queue is not maintained between power cycles. Any messages in the queue when the terminal is reset are cleared.

Alarms

Applications that support alarms may contain:

- Alarm Banner display that pops up when an alarm is triggered
- Alarm buttons that enable the operator to act on an alarm (Print Alarm, Acknowledge Alarm, Clear Alarm, Acknowledge All)
- Alarm List which stores information on triggered alarms (Print Alarm List or Clear Alarm List button)

Alarm configurations are application dependent. Consult your application designer for details on how to handle alarms for your application.

Installing the PV550 Terminal

Chapter Objectives

This chapter describes how to mount the PV550 terminal in a panel or enclosure including:

- hazardous locations
- enclosures
- required tools
- mounting dimensions
- clearances
- cutout dimensions
- installing the PV550 terminal in a panel

Hazardous Locations

See the nameplate label on terminal for hazardous locations certifications.



ATTENTION: In Class 1, Division 2 Hazardous locations, the PanelView 550 terminal must be wired per the National Electric Code as it applies to hazardous locations. Peripheral equipment must also be suitable for the location in which it is installed.

The following PV550 terminals have an operating temperature code of T2 (maximum operating temperature of 300° C or 572° F).

- keypad terminals (series C or higher)
- keypad & touch screen terminals (series C or higher)
- all touch screen only terminals

Do not install these terminals in environments where atmospheric gases have ignition temperatures less than 300° C (572° F).

Enclosures

Mount the PV550 terminal in a panel or enclosure to protect the internal circuitry. The terminal meets NEMA Type 12/13 and 4X (indoor ruse) ratings only when mounted in a panel or enclosure with the equivalent rating.

Allow enough space within the enclosure for adequate ventilation. Consider heat produced by other devices in the enclosure. The ambient temperature around the terminals must be between 0° and 55° C (32° and 131° F).

Make provisions to access the back panel of the terminal for wiring, maintenance, installing a memory card and troubleshooting.

Required Tools

Other than the tools required to make the PV550 panel cutout, the tools required for installation are:

- 7 mm (M4) deep well socket wrench or nut driver
- small slotted screwdriver
- torque wrench (in / lbs)

Mounting Dimensions

The illustration below shows mounting dimensions for the PV550 terminals.

PV550 Keypad, Keypad & Touch Screen Terminals

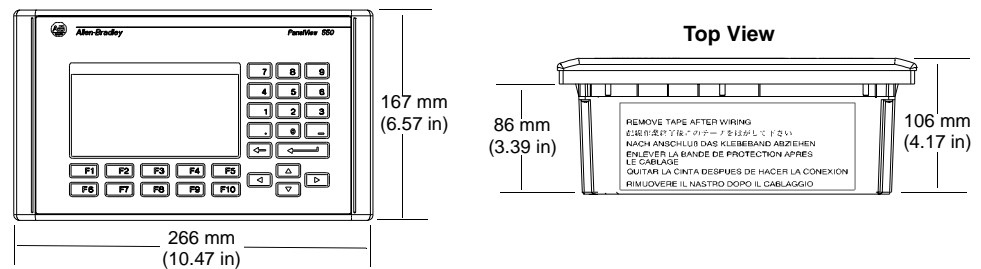

PV550 Touch Screen Terminals

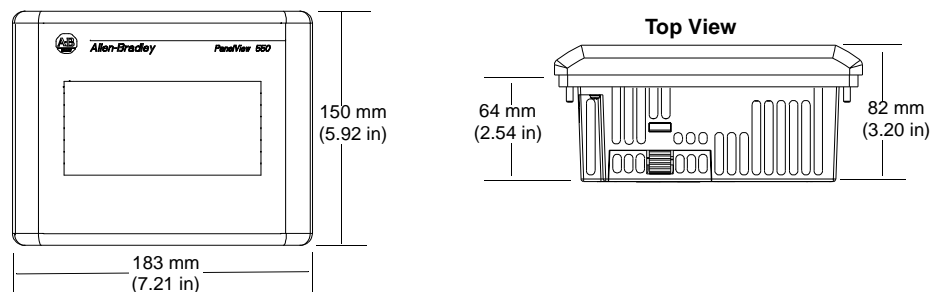

Clearances

When installing the PV550 terminal, allow space for mounting, air flow, maintenance, memory card and legend strip installation

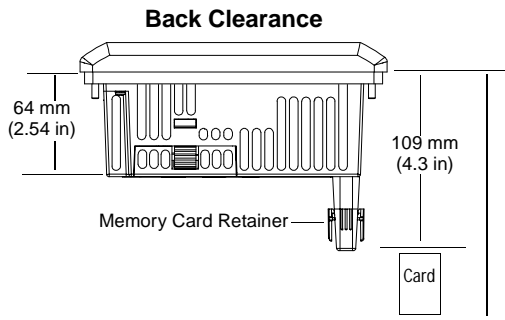
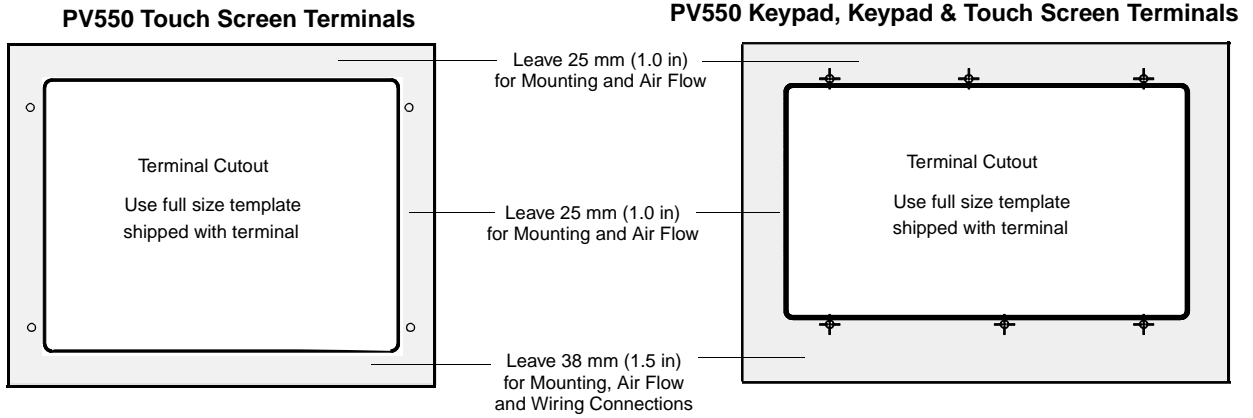

207 mm (8.15 in) is required to insert and remove a memory card with the memory card retainer.

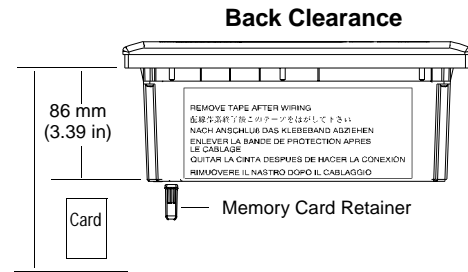

Cutout Dimensions

Use the full size template shipped with the PV550 terminal to mark the cutout dimensions. Below is a reduce size cutout.

PV550 Keypad, Keypad & Touch Screen Terminals

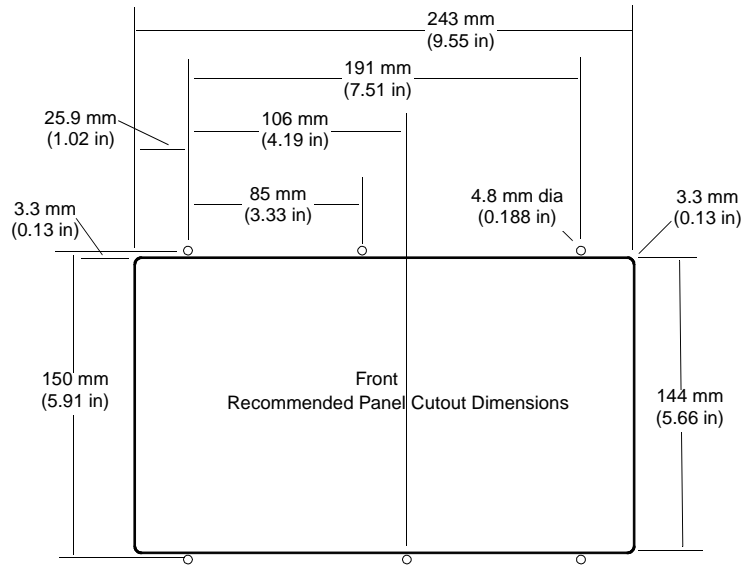

PV550 Touch Screen Terminals

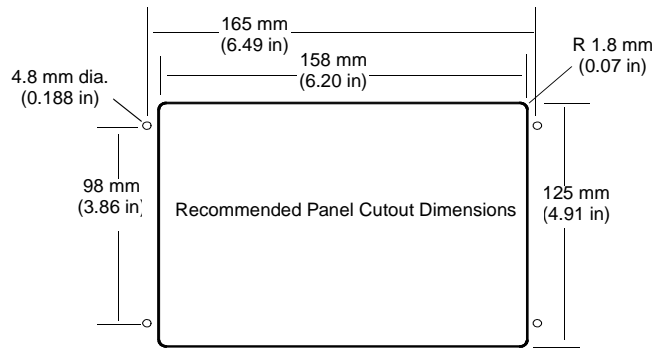

Installing the PV550 in a Panel

To install the PV550 terminal in a panel:



ATTENTION: Disconnect all electrical power from the panel before making the cutout.

Make sure the area around the panel cutout is clear.

Do not allow metal cuttings to enter any components that may already be installed in the panel.

Failure to follow this warning may result in personal injury or damage to the panel components.

1. Cut an opening in the panel using the panel cutout provided with the terminal. Remove any sharp edges or burrs.
2. Make sure the terminal sealing gasket is properly positioned on the terminal as shown below. This gasket forms a compression type seal. Do not use sealing compounds.

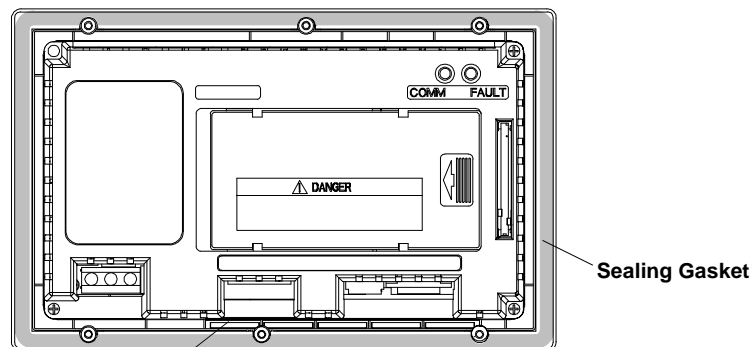

Adhesive Legend Strip
(Keypad and Keypad & Touch Screen Terminals only)

3. On the keypad and keypad & touch screen terminals, secure the ends of the legend strips to the legend strip adhesive.
4. Place the terminal in the panel cutout.
5. Verify that the opening is the proper size to clear the bezel and to allow the gasket to contact the panel.
6. On the keypad and keypad & touch screen terminals, position the ends of the legend inserts behind the panel cutout.
7. Install the self-locking nuts hand tight

PV550 Keypad, Keypad & Touch Screen Terminals.

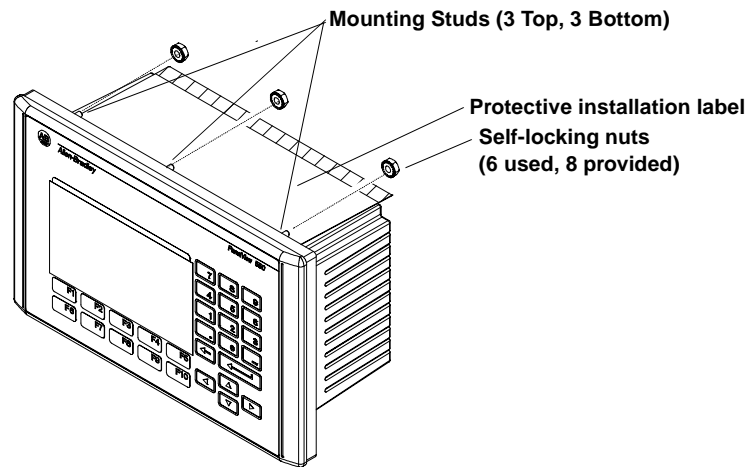

PV550 Touch Screen Terminal

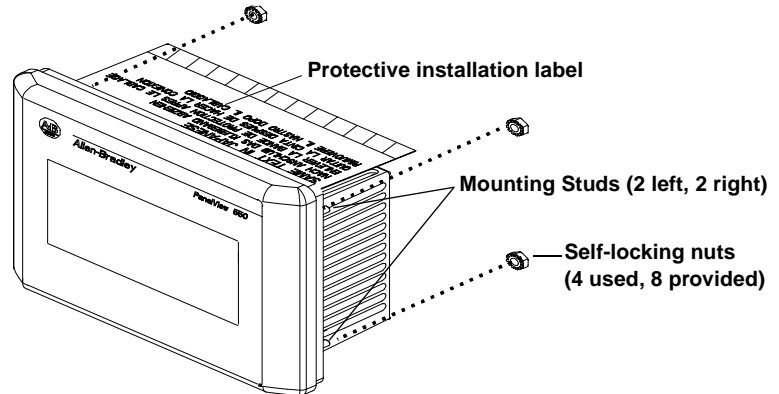

8. Alternately tighten the self-locking nuts until the terminal is held firmly against the panel. Tighten nuts to a torque of 10 inch-pounds. Do not over-tighten.



ATTENTION: Mounting nuts must be tightened to a torque of 10 inch-pounds to provide a proper seal and to prevent potential damage to the terminal. Allen-Bradley assumes no responsibility for water or chemical damage to the terminal or other equipment within the enclosure because of improper installation.

9. Remove the protective installation label covering the top vents of the terminal.



ATTENTION: Failure to remove the protective installation label covering the top vents could result in overheating and damage to the terminal.

Installing the PV600 Terminal

Chapter Objectives

This chapter describes how to mount the PV600 terminal in a panel or enclosure including:

- hazardous locations
- enclosures
- required tools
- mounting dimensions
- cutout dimensions
- clearances
- installing the PV600 terminal in a panel

Hazardous Locations

See the nameplate label on terminal for certifications on hazardous locations.



ATTENTION: In Class 1, Division 2 Hazardous locations, the PanelView terminal must be wired per the National Electric Code as it applies to hazardous locations. Peripheral equipment must also be suitable for the location in which it is installed.

The PV600 terminals have an operating temperature code of T4 (maximum operating temperature of 135° C or 275° F). **Do not** install the terminals in environments where atmospheric gases have ignition temperatures less than 135° C (275° F).

Enclosures

Mount the PV600 terminal in a panel or enclosure to protect the internal circuitry. The terminal meets NEMA Type 12/13 and 4X (indoor ruse) ratings only when mounted in a panel or enclosure with the equivalent rating.

Allow enough space within the enclosure for adequate ventilation. Consider heat produced by other devices in the enclosure. The ambient temperature around the terminals must be between 0° and 55° C (32° and 131° F).

Make provisions to access the back panel of the terminal for wiring, maintenance, installing a memory card and troubleshooting.

Required Tools

Other than the tools required to make the PV600 panel cutout, the tools required for installation are:

- small slotted screwdriver
- torque wrench (in. / lbs)
- #2 phillips screwdriver
- #2 phillips bit for torque wrench

Mounting Dimensions

The illustration below shows mounting dimensions for the PV600 terminals.

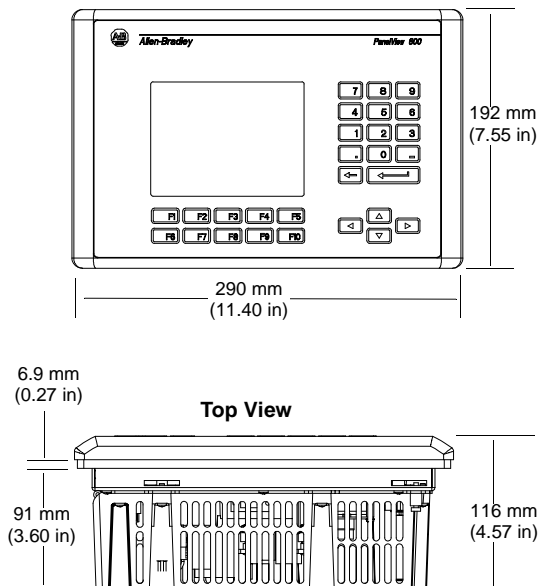

Cutout Dimensions

Use the full size template shipped with the PV600 terminal to mark the cutout dimensions. Below is a reduce size cutout.

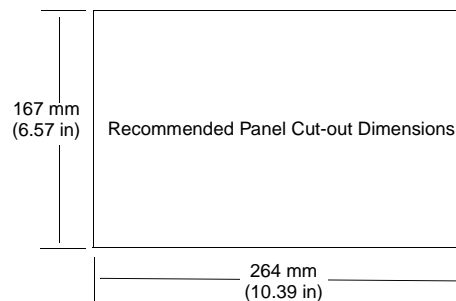

Clearances

When installing the PV600 terminal, allow adequate space for mounting, air flow, maintenance, memory card and legend strip installation.

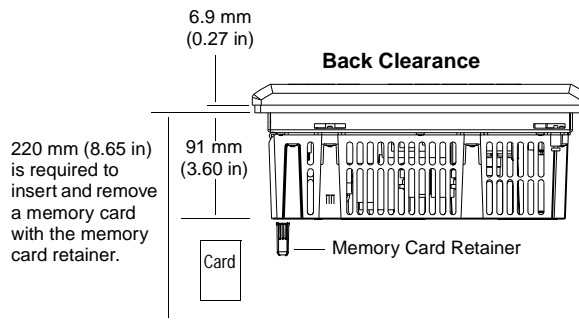
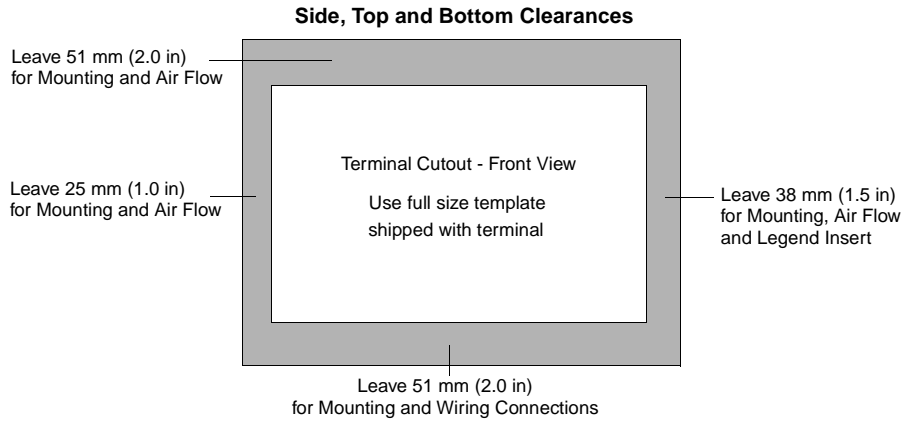

Installing the PV600 in a Panel

To install the PV600 terminal in a panel:



ATTENTION: Disconnect all electrical power from the panel before making the cutout.

Make sure the area around the panel cutout is clear.

Do not allow metal cuttings to enter any components that may already be installed in the panel.

Failure to follow this warning may result in personal injury or damage to the panel components.

1. Cut an opening in the panel using the panel cutout provided with the terminal. Remove any sharp edges or burrs.
2. Make sure the terminal sealing gasket is properly positioned on the terminal as shown below. This gasket forms a compression type seal. Do not use sealing compounds.

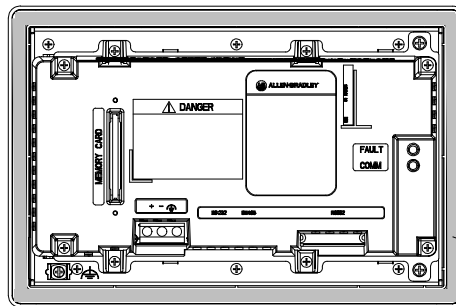

Sealing Gasket

3. Although the keypad legend strip can be installed any time, we recommend that you install it after the terminal is installed.
4. Place the terminal in the panel cutout.

5. Install the 4 mounting clips (2 on top, 2 on bottom). The ends of the clips slide into the slots on the terminal. Tighten the clip mounting screws by hand until the gasket seal contacts the mounting surface uniformly.

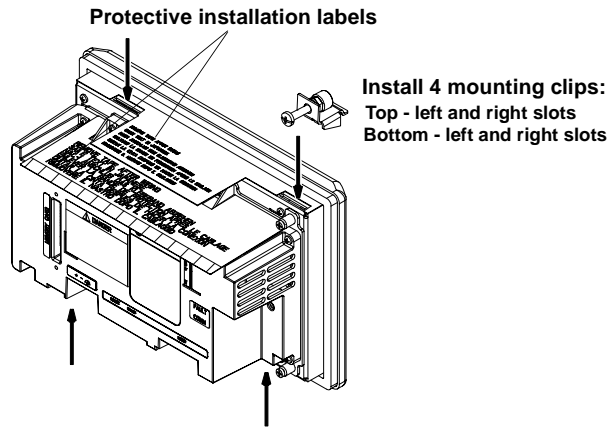

6. Alternately tighten the mounting clip screws to a torque of 10 inch-pounds. Do not over-tighten.



ATTENTION: Tighten mounting clips to a torque of 10 inch-pounds to provide a proper seal and to prevent potential damage to the terminal. Allen-Bradley assumes no responsibility for water or chemical damage to the terminal or other equipment within the enclosure because of improper installation.

7. Remove the 2 protective installation labels covering the top vents of the terminal.



ATTENTION: Remove the protective installation labels covering the top vents to prevent overheating and damage to the terminal.

Installing the PV900/1000 Terminals

Chapter Objectives

This chapter describes how to mount the PV900 and PV1000 terminals in a panel or enclosure including:

- hazardous locations and enclosures
- required tools
- mounting dimensions
- clearances
- cutout dimensions
- installing the PV900/PV1000 terminal in a panel

Hazardous Locations

See the nameplate label on terminal for certifications on hazardous locations.



ATTENTION: In Class 1, Division 2 Hazardous locations, the PanelView terminal must be wired per the National Electric Code as it applies to hazardous locations. Peripheral equipment must also be suitable for the location in which it is installed.

The PV900/PV1000 terminals have an operating temperature code of T4 (maximum operating temperature of 135° C or 275° F). **Do not** install the terminals in environments where atmospheric gases have ignition temperatures less than 135° C (275° F).

Enclosures

The PV900/PV1000 terminal must be mounted in an environment that provides IEC-1131-2 Pollution degree 2 protection.

Mount the terminal in a panel or enclosure to protect the internal circuitry. The terminal meets NEMA Type 12/13 and 4X (indoor ruse) ratings only when mounted in a panel or enclosure with the equivalent rating.

Allow enough space within the enclosure for adequate ventilation. Consider heat produced by other devices in the enclosure. The ambient temperature around the terminals must be between 0° and 55° C (32° and 131° F).

Make provisions to access the back panel of the terminal for wiring, maintenance, installing a memory card and troubleshooting.

Required Tools

Other than the tools required to make the panel cutout, the tools required for installation are:

- small slotted screwdriver
- torque wrench (in. / lbs) with slotted or phillips head driver

Mounting Dimensions

PV900 Terminals

The illustrations below show mounting dimensions for the PV900 monochrome and color terminals.

PV900 Touch Terminal Mounting Dimensions

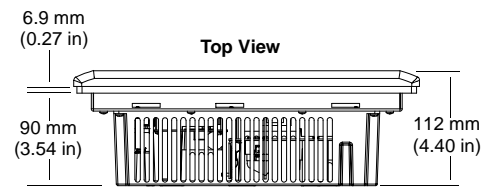
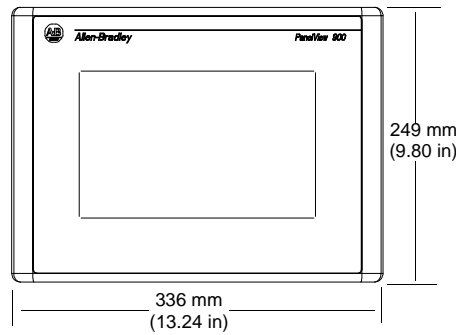

PV900 Keypad Terminal Mounting Dimensions

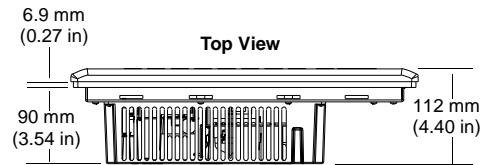
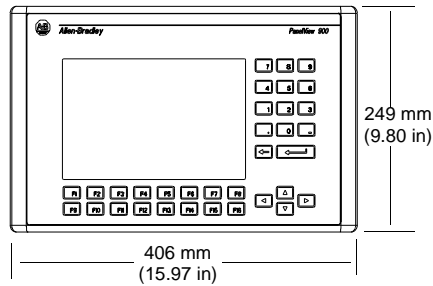

PV1000 Terminals

The illustrations below show the mounting dimensions for the PV1000 grayscale and color terminals.

PV1000 Touch Terminal Mounting Dimensions

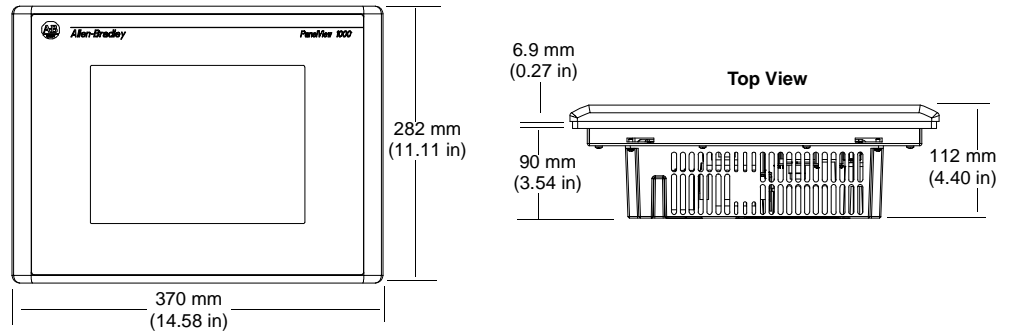

PV1000 Keypad Terminal Mounting Dimensions

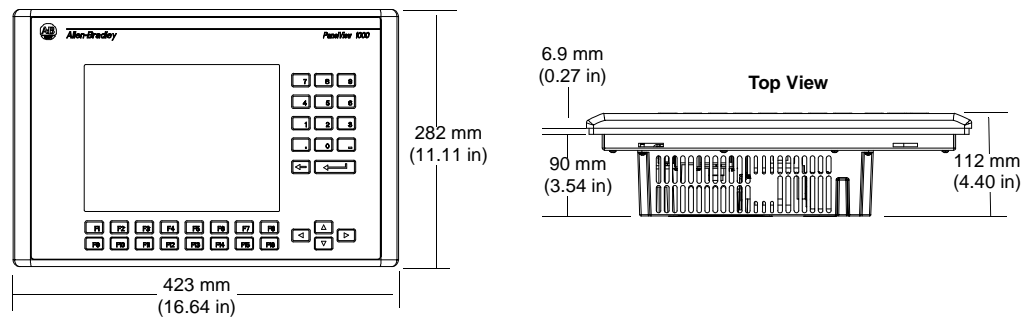

Clearances

Allow adequate space for mounting, air flow, maintenance, memory card and legend strip installation.

Important: If using a memory card and/or memory card retainer, allow a back clearance to load the card.

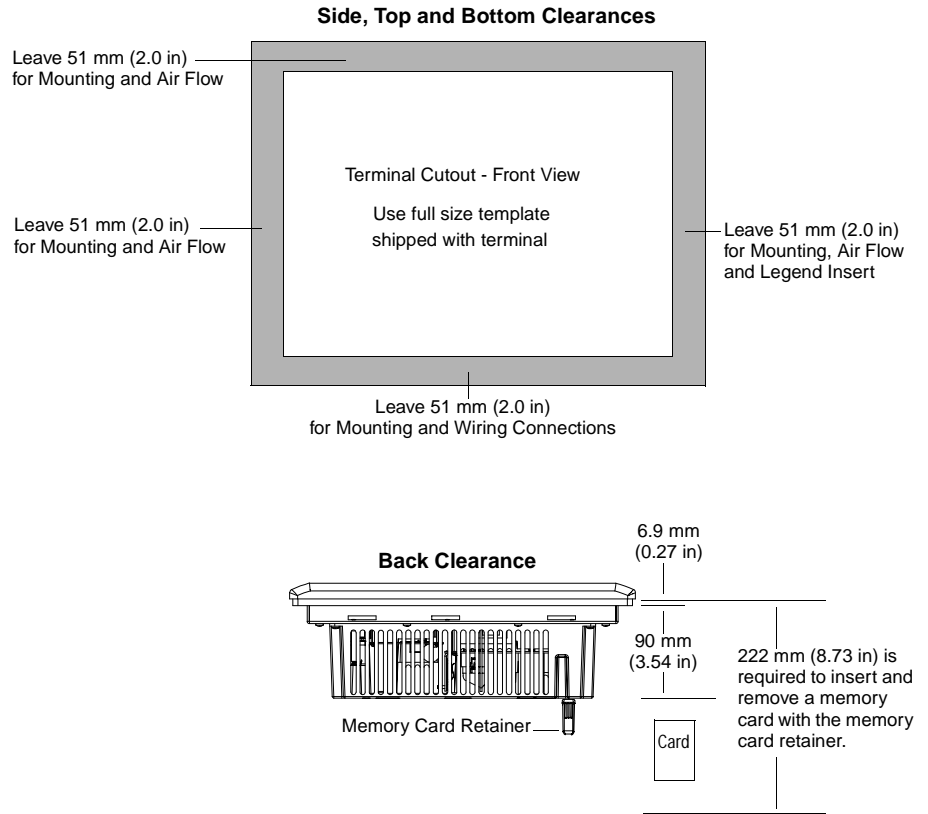

Cutout Dimensions

Use the full size template shipped with the PV900 and PV1000 terminals to mark the cutout dimensions. The following illustrations show reduced cutouts for these terminals with dimensions.

PV900 Panel Cutout Dimensions

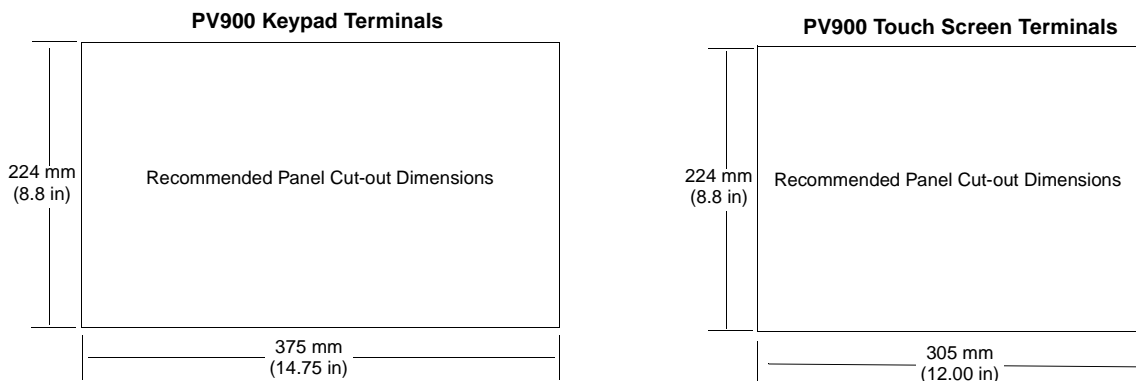

PV1000 Panel Cutout Dimensions

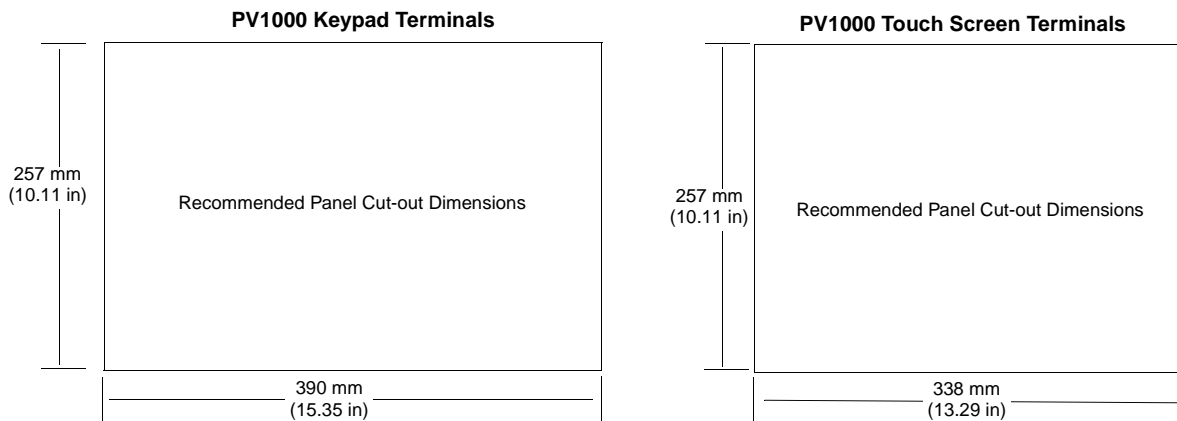

Installing the PV900/PV1000 in a Panel

To install the PV900/PV1000 terminal in a panel:



ATTENTION: Disconnect all electrical power from the panel before making the cutout.

Make sure the area around the panel cutout is clear.

Do not allow metal cuttings to enter any components that may already be installed in the panel.

Failure to follow this warning may result in personal injury or damage to the panel components.

1. Cut an opening in the panel using the panel cutout provided with the terminal. Remove any sharp edges or burrs.
2. Make sure the terminal sealing gasket is properly positioned on the terminal as shown below. This gasket forms a compression type seal. Do not use sealing compounds.

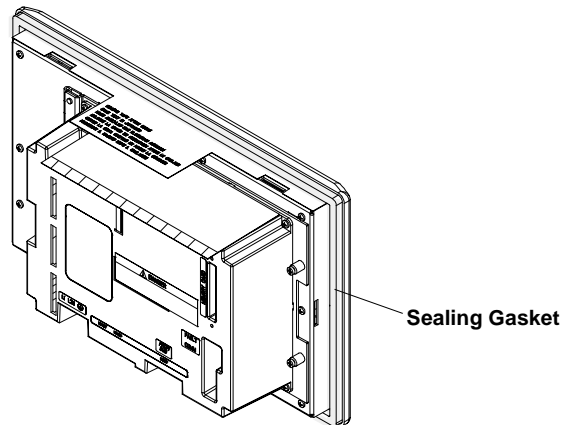

3. Although the keypad legend strip can be installed any time, we recommend that you install it after the terminal is installed.
4. Place the terminal in the panel cutout.

5. Install the 6 mounting clips (2 on top, 2 on bottom, 1 on each side). The ends of the clips slide into the slots on the terminal. Tighten the clip mounting screws by hand until the gasket seal contacts the mounting surface uniformly.

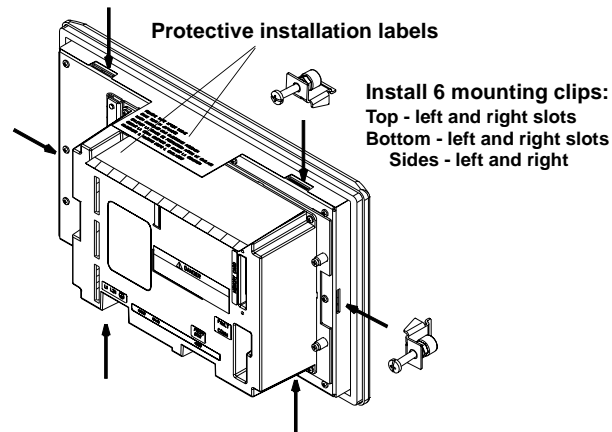

6. Alternately tighten the mounting clip screws to a torque of 10 inch-pounds. Do not over-tighten.



ATTENTION: Tighten mounting clips to a torque of 10 inch-pounds to provide a proper seal and to prevent potential damage to the terminal. Allen-Bradley assumes no responsibility for water or chemical damage to the terminal or other equipment within the enclosure because of improper installation.

7. Remove the 2 protective labels covering the top vents of the terminal.



ATTENTION: Remove the protective installation labels covering the top vents to prevent overheating and damage to the terminal.

Installing the PV1400 Terminal

Chapter Objectives

This chapter describes how to mount the PV1400 terminal in a panel or enclosure including:

- enclosures
- recommended tools
- mounting dimensions
- clearances
- cutout dimensions
- installing the PV1400 terminal in a panel

Enclosures

The PV1400 terminal must be mounted in an environment that provides IEC-1131-2 Pollution degree 2 protection.

Mount the PV1400 terminal in a panel or enclosure to protect the internal circuitry. The terminal meets NEMA Type 12/13 and 4X (indoor ruse) ratings only when mounted in a panel or enclosure with the equivalent rating.

Allow enough space within the enclosure for adequate ventilation. Consider heat produced by other devices in the enclosure. The ambient temperature around the terminals must be between 0° and 55° C (32° and 131° F).

Make provisions to access the back sides of the terminal. Access is required for wiring, routine maintenance, adjusting brightness/contrast, installing a memory card and troubleshooting.

Required Tools

In addition to the tools required to make the panel cutout, you need the tools below.

For clip mounting:

- socket screwdriver (phillips head or slotted)
- 16-inch (406 mm) extension rod (minimum)
- socket driver (in/lb torque wrench recommended)

For stud mounting:

- 7/32 and 3/8 inch socket
- 16-inch (406 mm) extension rod (minimum)
- socket driver (in/lb torque wrench recommended)

Mounting Dimensions

The illustrations below show mounting dimensions for the PV1400 terminals.

PV1400 Touch Terminal Mounting Dimensions

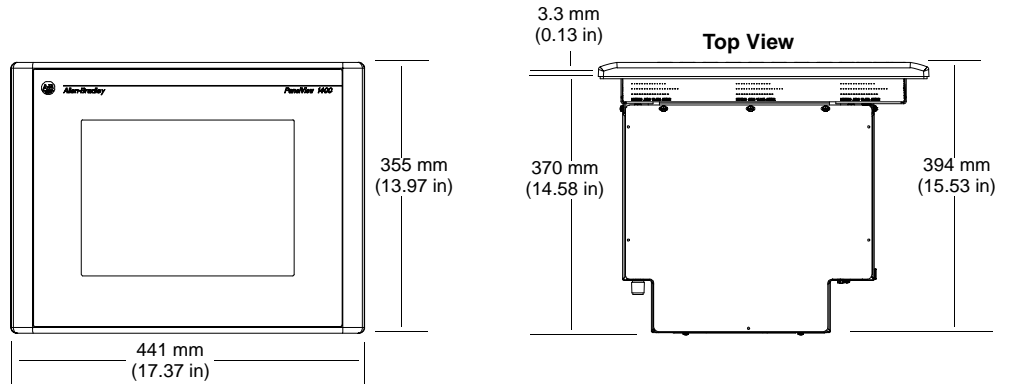

PV1400 Keypad Terminal Mounting Dimensions

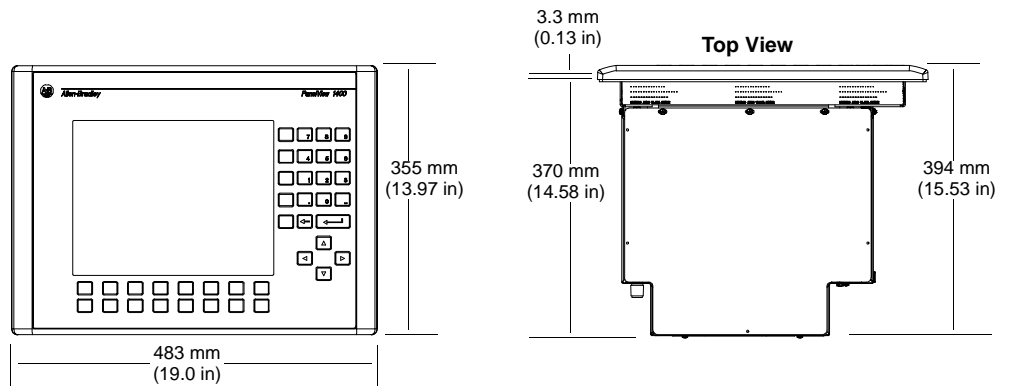

Clearances

Allow adequate space for mounting, air flow, maintenance, adjusting brightness/contrast, memory card and legend strip installation.

Important: If using a memory card, allow a back clearance to load the card.

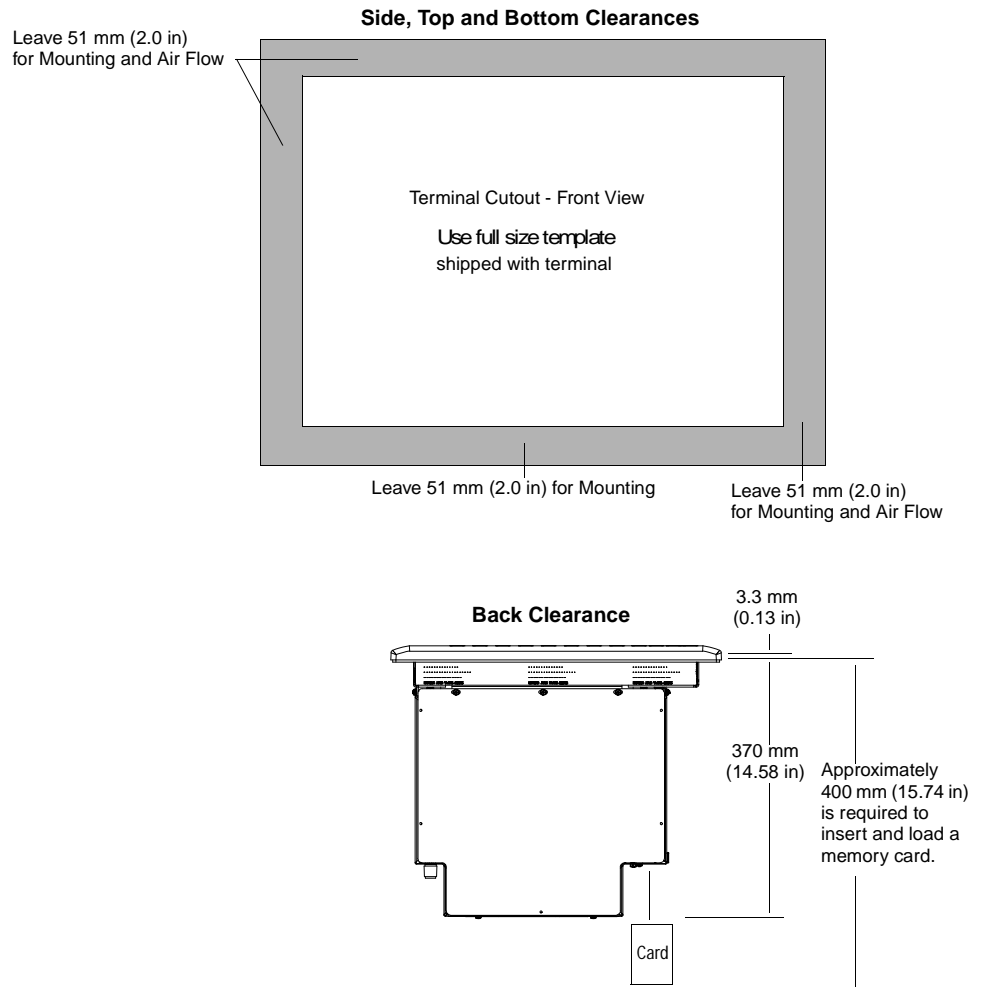

Cutout Dimensions

Use the full size template provided with the terminal to mark cutout dimensions. The illustration below shows reduced size cutouts with dimensions.

PV1400 Keypad Terminals

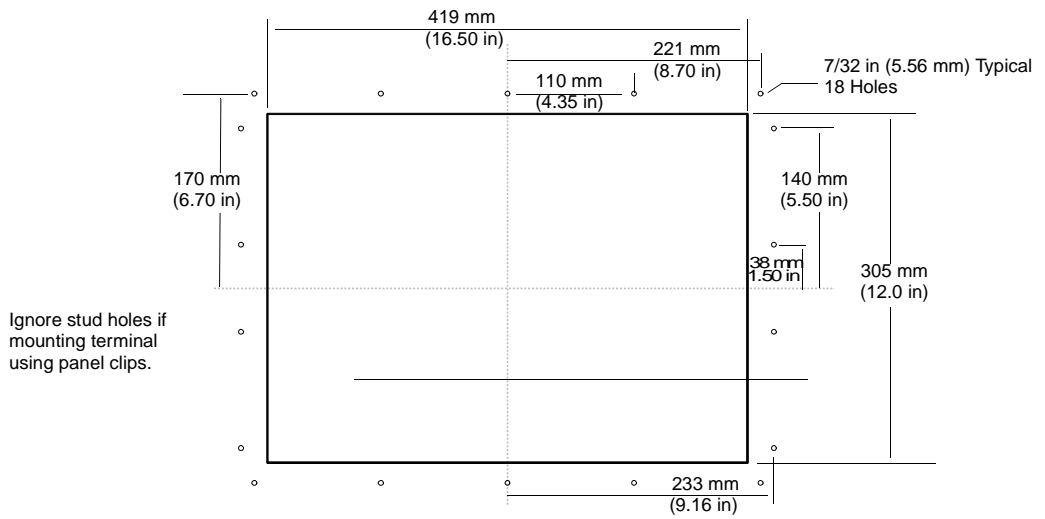

PV1400 Touch Screen Terminals

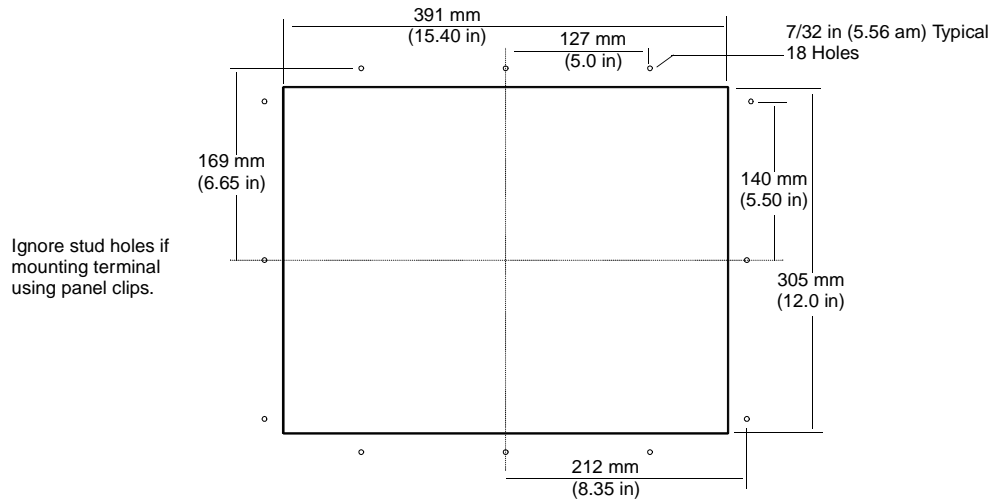

Installing the PV1400 in a Panel

This section gives procedures for mounting a PV1400 using:

- mounting clips (10 shipped with terminal, 10 required)
- mounting studs (ordered separately, Catalog No. 2711-NP3)



ATTENTION: Disconnect all electrical power from the panel before making the cutout.

Make sure the area around the panel cutout is clear.

Do not allow metal cuttings to enter any components that may already be installed in the panel.

Failure to follow this warning may result in personal injury or damage to the panel components.

To install the PV1400 terminal in a panel using clips:

1. Cut an opening in the panel using the panel cutout provided with the terminal. Remove any sharp edges or burrs. Do not drill the mounting stud holes if you are using clips.
2. Make sure the sealing gasket is properly positioned on the terminal as shown below. This gasket forms a compression type seal. Do not use sealing compounds.

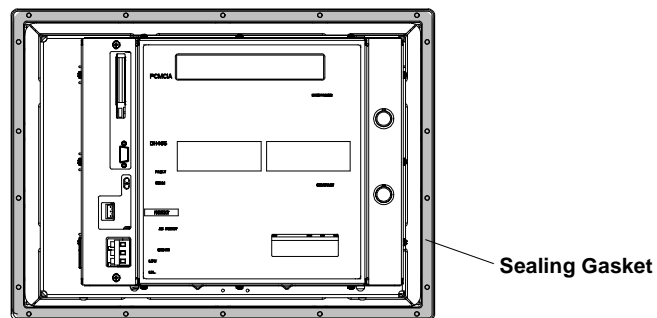

3. Although the keypad legend strip can be installed any time, we recommend that you install them after the terminal is installed.
4. Place the PV1400 in the panel cutout. The terminal will snap into the panel as the temporary retaining tabs lock against the panel.

Note: The PV1400 has 2 metal tabs (on bottom edge) that temporarily lock the terminal against the panel. These tabs only facilitate installation of the mounting hardware. The tabs are not designed to provide permanent mounting.

5. Install the 10 mounting clips (3 on top, 3 on bottom, 2 on each side). The ends of the clips slide into slots on the terminal. Tighten the clip mounting screws hand tight.

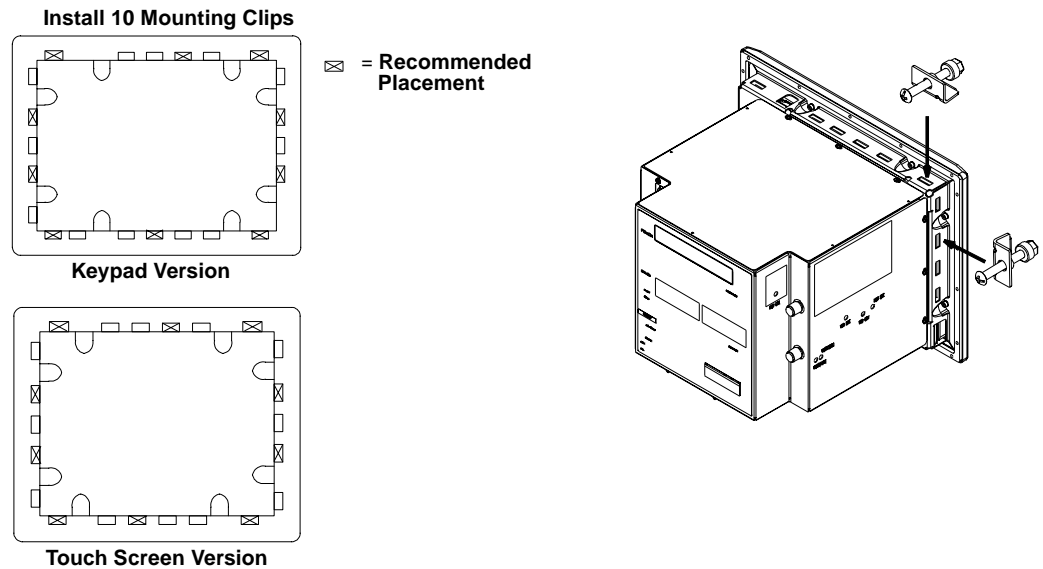

6. Alternately tighten the mounting clip screws until the terminal is held firmly against the panel. Tighten mounting screws to a torque of 10 inch-pounds. Do not over-tighten.



ATTENTION: Tighten mounting clips to a torque of 10 inch-pounds to provide a proper seal and to prevent potential damage to the terminal. Allen-Bradley assumes no responsibility for water or chemical damage to the terminal or other equipment within the enclosure because of improper installation.

To install the PV1400 terminal in a panel using mounting studs:

1. Cut an opening in the panel using the panel cutout shipped with the terminal. Carefully drill 5.56 mm (7/32 inch) holes for studs as indicated.
2. Install the mounting studs (Catalog No. 2711-NP3) using a 7/32-inch socket on the end of the stud. Turn stud clockwise and tighten to approximately 10-inch pounds (1.1 N•m).

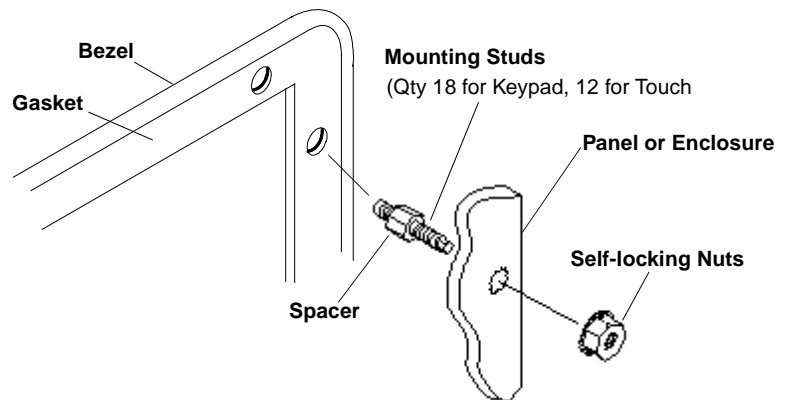

3. Make sure the sealing gasket is properly positioned on the terminal. This gasket forms a compression type seal (NEMA Type 4). Do not use sealing compounds



ATTENTION: Be careful not to damage the sealing gasket when installing or removing studs. A damaged seal may result in damage to the PanelView terminal and other panel components due to a leaking seal.

4. Place the PV1400 in the panel cutout aligning the studs with the mounting holes.

5. Install the self-locking nuts hand tight.



ATTENTION: Tighten mounting nuts to a torque of 10 inch-pounds (1.1 N•m) to provide a proper seal and prevent potential damage to the terminal. Allen-Bradley assumes no responsibility for water or chemical damage to the terminal or other equipment within the enclosure because of improper installation.

6. Alternately tighten the self-locking nuts (use 3/8 inch socket) until the PV1400 is held firmly against the panel. (The recommended tightening sequence is shown below).

The studs have an integral spacer that prevents the gasket from being over-compressed. The amount of torque required increases significantly as the gasket reaches the proper compression. Tighten nuts to a torque of 10 inch-pounds (1.1 N•m).

18	9	1	5	13
16				15
4	Recommended Torque Sequence Keypad Terminals			3
7				8
12				11
17	10	2	6	14

	9	1	5	
7				8
4	Recommended Torque Sequence Touch Terminals			3
12				11
	10	2	6	

Note that sequence starts at center studs and continues to the corner studs.

Making Terminal Connections

Chapter Objectives

This chapter describes network and device connections for PanelView terminals.

- wiring and safety guidelines
- Remote I/O connections
- DH+ connections
- DH-485 connections
- RS-232 (DH-485) connections
- ControlNet connections
- DeviceNet connections
- DF1 connections
- Computer or printer connection to RS-232 serial port

Wiring and Safety Guidelines

Use publication NFPA 70E, Electrical Safety Requirements for Employee Workplaces when wiring the PanelView terminals. In addition to the NFPA general guidelines:

- route communication cables to terminal by a separate path from incoming power.



ATTENTION: Do not run signal wiring and power wiring in the same conduit.

- where power and communication lines must cross, they should cross at right angles. Communication lines can be installed in the same conduit as low level DC I/O lines (less than 10 volts).
- grounding minimizes noise from Electromagnetic Interference (EMI) and is a safety measure in electrical installations.
- use the National Electric Code published by the National Fire Protection Association as a source for grounding.

Remote I/O Terminal Connections

This section describes connections for the Remote I/O PanelView terminals including:

- Remote I/O port
- supported controllers
- making Remote I/O connections
- Remote I/O Pass-Through

Remote I/O Terminal Ports

The Remote I/O versions of the PanelView terminal (catalog numbers ending in 1) have a Remote I/O port and an RS-232 port.

Use the Remote I/O port to:

- communicate with the Remote I/O scanner port on a PLC controller
- communicate with SLC controllers using a 1747-SN Remote I/O scanner module
- communicate with other Remote I/O scanners
- transfer applications using Remote I/O Pass-Through

Use the RS-232 Port to:

- transfer PanelView applications between a computer and the terminal.
- connect a printer.

For details on connecting to the RS-232 port, see the last section in this chapter.

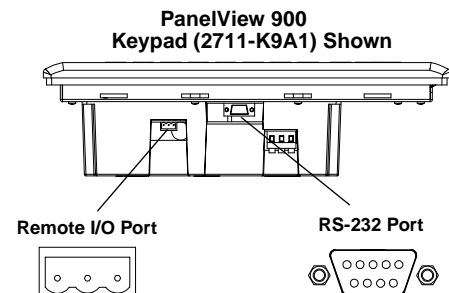
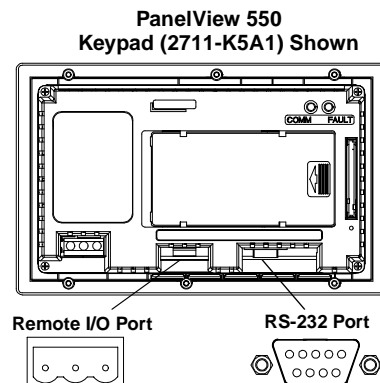

Supported Controllers

The Remote I/O terminal connects to any Allen-Bradley 1771 Remote I/O link. Applicable host controllers include almost all Allen-Bradley PLCs, computers, VME controllers, and DEC Q-Bus controllers with a Remote I/O scanner module. New PLC product releases that support 1771 Remote I/O will also work with PanelView.

When connecting a PanelView terminal to a controller refer to the user manual for your controller or scanner module for connection diagrams and any Remote I/O limitations. The table below provides a summary of possible connections.

Controller	Scanner	Comments
PLC-5/11, 5/15 ¹ , 5/20, 5/25, 5/30, 5/60, 5/250	PLC Integral 1771-SN	Connect PanelView terminals directly to the Remote I/O port (scanner mode). Connect PanelView terminals through the 1771-SN subscanner module.
PLC-5/10, 5/12	1771-SN	Connect PanelView terminals through the 1771-SN subscanner module.
PLC-2	1771-SN or 1772-SD2 ²	Connect PanelView terminals to the PLC-2 family of processors through a 1771-SN I/O subscanner module.
PLC-3 and PLC-3/10	None PLC-3/10 Remote I/O Scanner ³	Connect PanelView terminals directly to a PLC-3. Connect PanelView terminals to the PLC-3/10 through the Remote I/O scanner.
SLC-5/00, 5/02, 5/03, 5/04, 5/05	1747-SN	Connect PanelView terminals through the 1747-SN subscanner module. Each module provides an additional Remote I/O link for up to 4 racks. Important: Only Series B and later versions of the 1747-SN subscanner support block transfers.
IBM PC	6008-SI	6008-SI I/O scanner is compatible with IBM PC or compatible computers. The scanner provides a computer access to the 1771 Remote I/O link.
VME	6008-SV	6008-SV I/O scanner provides access to the 1771 Remote I/O link for VME controllers.
DEC Q-BUS	6008-SQ	6008-SQ I/O scanner provides access to the 1771 Remote I/O link for DEC Q-BUS controllers.

¹ If using a PLC-5/15 with partial rack addressing and block transfers, you must use Series B, Rev. J or later.

² If using a 1775-SD2 Remote Scanner/Distribution Panel, use revision 3 or later.

³ If using a 1775-S4A Remote Scanner/Distribution Panel, use Series B or later.

Making Remote I/O Connections

To connect a PanelView terminal to a Remote I/O scanner, use cable Catalog No. 1770-CD (equivalent to Belden 9463). The maximum cable length (link distance) is determined by the baud rate.

- 2,800 meters (10,000 feet) for 57.6K baud
- 1,400 meters (5,000 feet) for 115.2K baud
- 700 meters (2,500 feet) for 230.4K

See Programmable Controller Wiring and Grounding Guidelines (Publication 1770-4.1). The user manual for the I/O scanner module also provides cabling information.

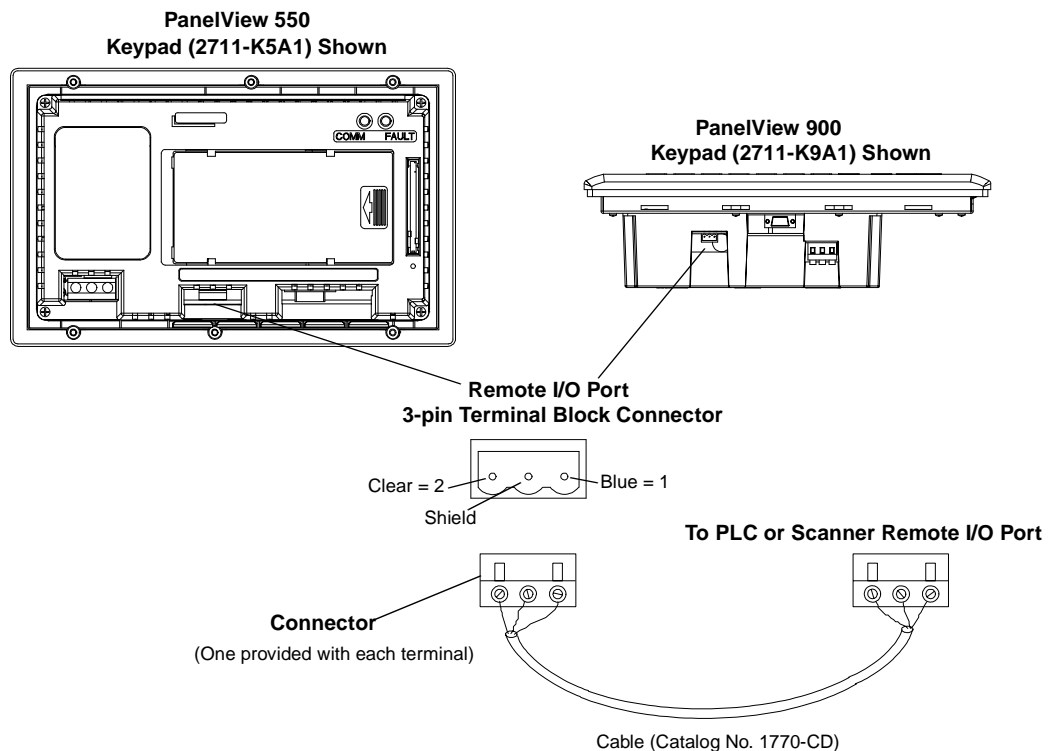

Note: The polarity of the Remote I/O Connector on the PanelView terminal is reversed from the PLC Scanner connector. However, the polarity is the same as the scanner card connection to the SLC.

Remote I/O Pass-Through

Remote I/O terminals allow the transfer of applications from a computer on the Allen-Bradley DH+ link to a PLC-5 controller. The controller passes data to the PanelView terminal over the Remote I/O network.

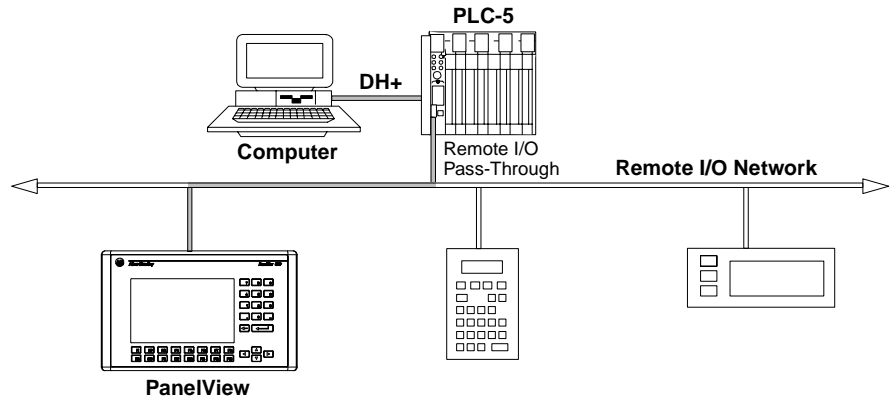

To transfer an application using Remote I/O Pass-Through:

1. A Data Highway Plus Interface Module must be installed in the computer. Allen-Bradley offers a variety of interface cards for a DH+ connection between a computer and a controller.
2. The appropriate communication driver must be configured on the computer.
3. Connect the computer to the PLC. See the instruction sheets provided with the communication module or card to select the proper cable. Connect the cable between the computer and the controller.
4. Pass-Through must be enabled for the terminal. Check the RIO Configuration screen on the terminal's Configuration Mode menu. Pass-Through is enabled using the out-of-box application provided with the terminal or when defining Remote I/O parameters in the PanelBuilder software.
5. Refer to the online help in the PanelBuilder software for procedures on how to transfer applications using Pass-Through.

DH-485 Terminal Connections

This section describes connections for the DH-485 PanelView terminals.

- DH-485 terminal ports
- Connecting to a single SLC controller (Point-to-Point)
- Connecting to a DH-485 network
- Connecting a Hand-held terminal
- Connecting a computer

DH-485 Terminal Ports

DH-485 PanelView terminals with catalog numbers ending in 2 have two DH-485 ports. Terminals with catalog numbers ending in 3 also have an RS-232 printer port.

Use the DH-485 Communications port to:

- communicate with a single or multiple SLC controllers over a DH-485 network.

Use the DH-485 SLC Programming connector to:

- upload/download PanelView applications
- monitor SLC operation, enter/modify SLC programs, test network devices

Use the RS-232 Printer port to:

- connect a printer that supports the IBM enhanced character set. For details on connecting to the RS-232 port, see the last section in this chapter.

The DH-485 communications port and programming connector may appear in different locations on specific terminals. Identify the ports by their size and shape or by the port labels.

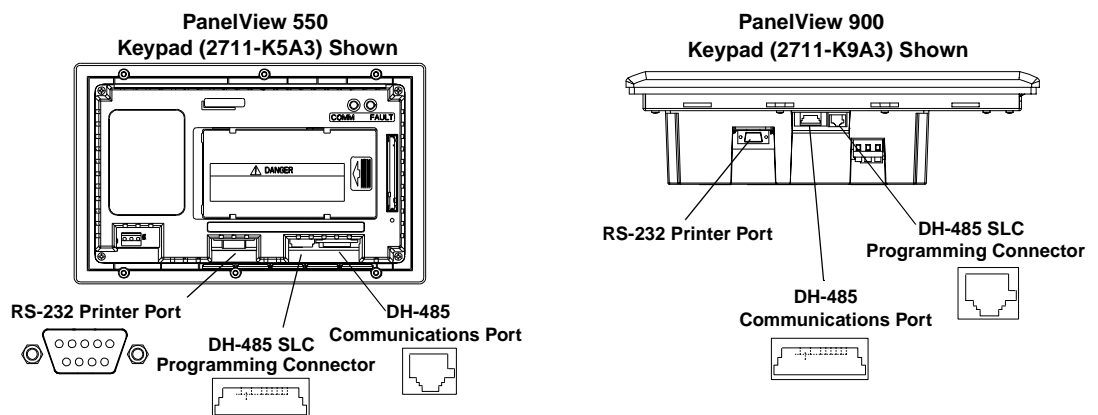

Connecting to a Single SLC Controller (Point-to-Point)

To connect a DH-485 terminal to a single SLC controller use one of these cables:

- 0.3 meter (1 foot) Catalog No. 1747-C11
- 1.83 meter (6 foot) Catalog No. 1747-C10
- 6.1 meter (20 foot) Catalog No. 1747-C20

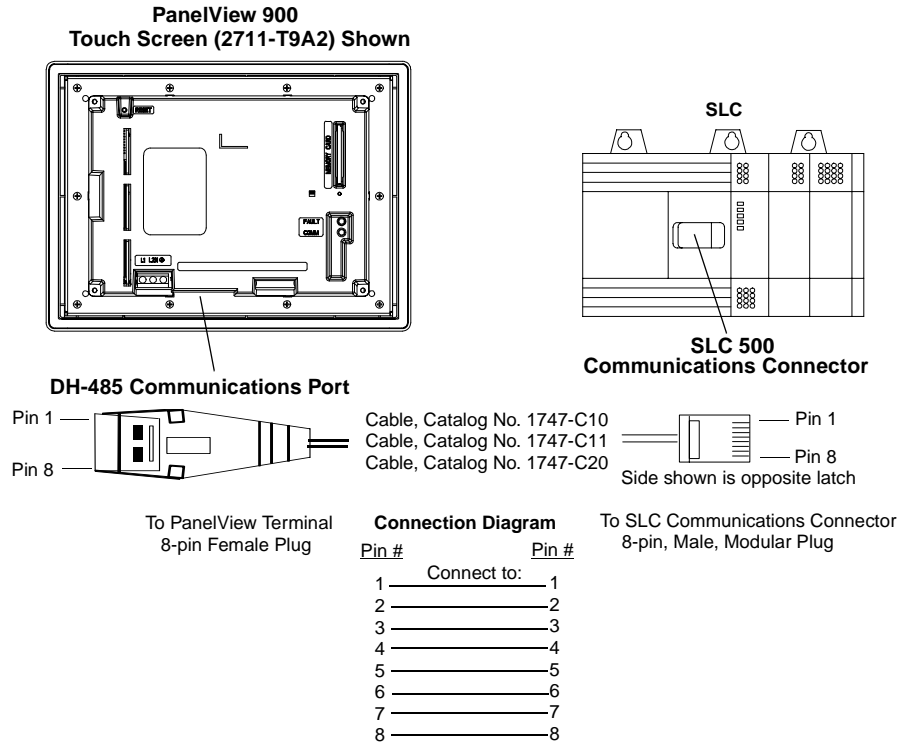

The DH-485 connectors are not electrically isolated. If electrical isolation is required, use Link Couplers (Catalog No. 1747-AIC) as shown on next page.



ATTENTION: Electrical isolation using Link Couplers (Catalog No. 1747-IC) is required where the distance between the PanelView terminal and the SLC is greater than 6.1 meters (20 feet).

Connecting to a DH-485 Network

This section shows how to connect a DH-485 terminal to multiple SLC controllers on a DH-485 network through the AIC Link Coupler.

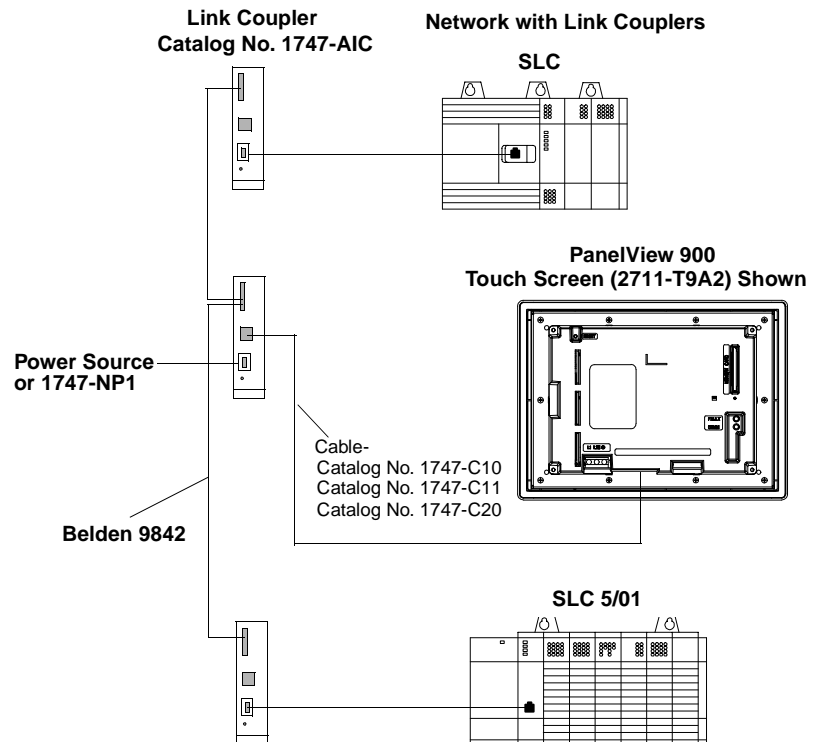

Important: The DH-485 network cable requires proper shielding, grounding and termination. Refer to Data Highway / Data Highway Plus / Data Highway-485 Cable Installation Manual (Publication No. 1770-6.2.2).

The illustration below shows how to connect a DH-485 terminal to a Micrologix or SLC controller using the AIC+ Link Coupler (Catalog No. 1761-NET-AIC).

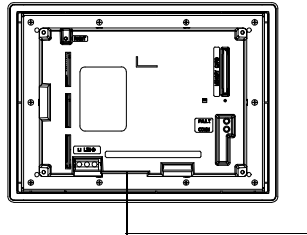

PanelView 900
Touch Screen (2711-T9A2) Shown

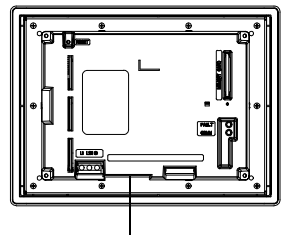
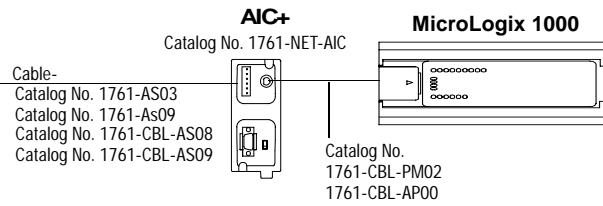

PanelView 900
Touch Screen (2711-T9A2) Shown

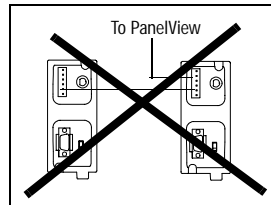
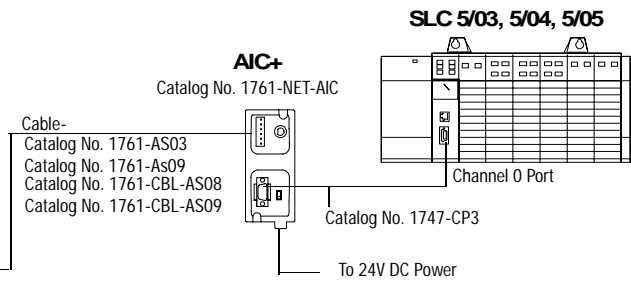

Do not connect the PanelView to Port 3 of the AIC+ when Port 3 is networked to other devices.

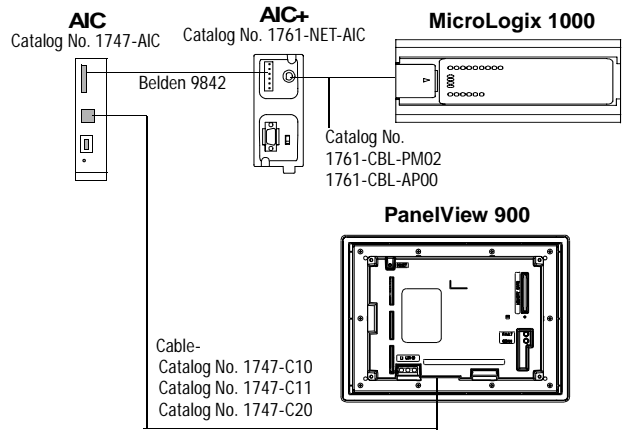

Connecting a Computer

On DH-485 terminals, PanelView applications are transferred:

- through the DH-485 programming connector to the terminal.
- through any node on a DH-485 network.

To connect a computer to the PanelView terminal, you need:

- a cable (same cables used to transfer applications from APS software to SLC)
 - 0.3 meter (1 foot) cable, Catalog No. 1747-C11
 - 1.83 meter (6 foot) cable, Catalog No. 1747-C10
 - 6.1 meter (20 foot) cable, Catalog No. 1747-C20
- Personal Computer Interface Converter (PIC), Catalog No. 1747-PIC. The PIC connects to the computer. The cable connects the PIC to the DH-485 programming connector.

Personal Computer Interface Converter (PIC)

The Personal Computer Interface Converter (PIC) receives power from a controller through DH-485 connections. When connecting a computer directly to a PanelView terminal without a controller connected, you need to use a power supply (Catalog No. 1747-NP1). The power supply connects to the DH-485 communications connector with the same cables used to connect an SLC.

Important: The terminal must be connected to an SLC, DH-485 network, or power supply (Catalog No. 1747-NP1). This connection provides power to the PIC.

Connecting Earth Ground to PanelView Terminals

When using the 1747-PIC converter with the PV600, PV900, PV1000 color and PV1000 grayscale terminals, you must connect the Earth Ground terminal on the back of the terminal to Earth Ground.

Connect the Earth Ground terminal using 14-gauge, stranded wire no longer than 1 meter (40 inches).

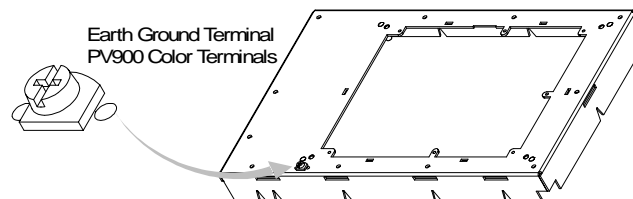

Connecting a Computer to DH-485 Connector using a Power Supply

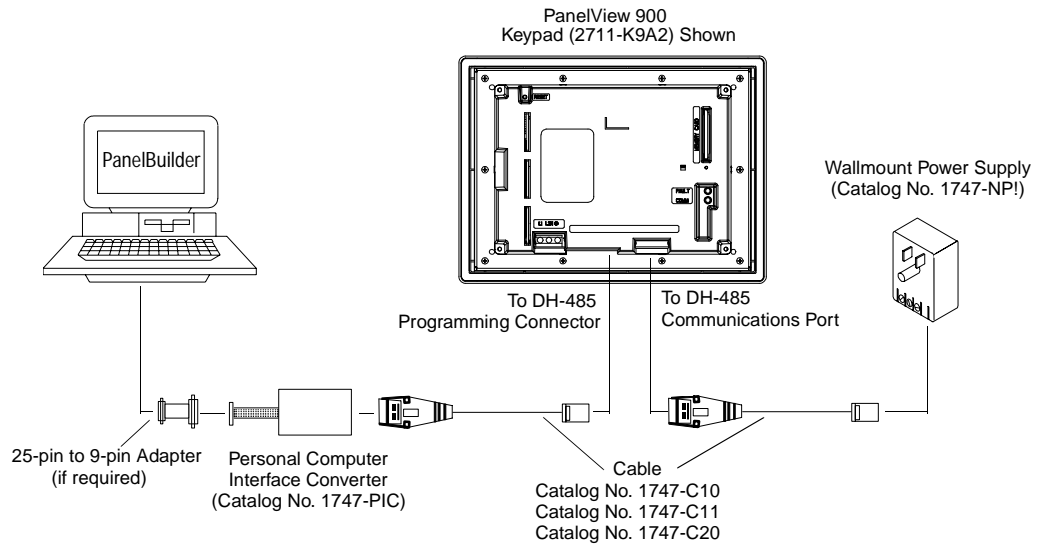

Connecting a Computer to DH-485 Connector using a DH-485 Powered Device

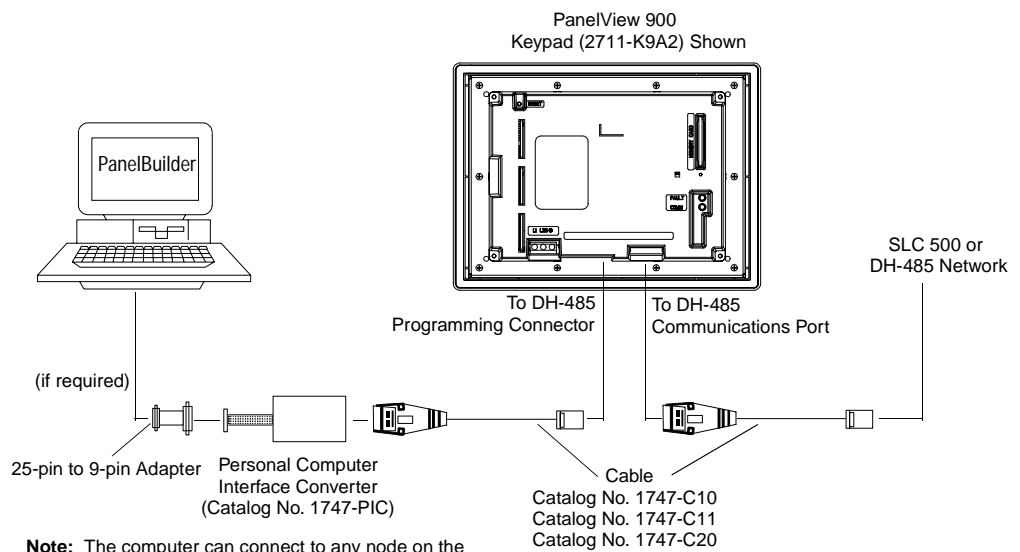

Note: The computer can connect to any node on the network. It is not necessary to directly connect the computer to the PanelView terminal.

Connecting a Hand-Held Terminal

To connect a Hand-Held Terminal (HHT) to the PanelView terminal, use cable Catalog No. 1747-C10. One end of the cable connect to the HHT connector and the other end connects to the DH-485 programming connector on the terminal. All power is supplied to the HHT through the cable.

Important: The PanelView terminal must be connected to an SLC, DH-485 network or power supply. This connection provides power for the HHT.

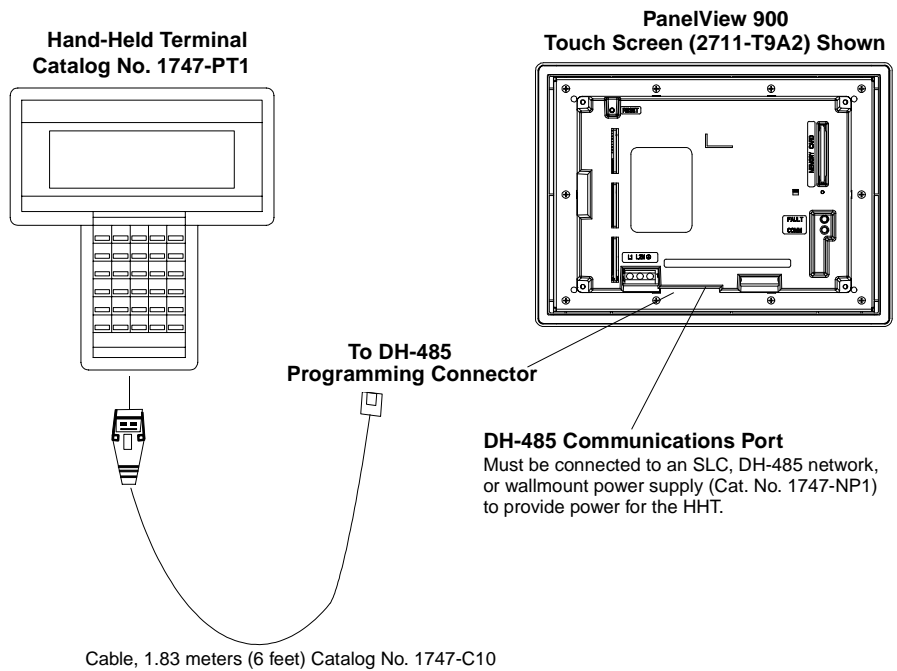

DH+ Terminal Connections

This section describes connections for the DH+ PanelView terminals including:

- DH+ connectors
- typical DH+ system configuration
- making DH+ connections

DH+ Terminal Ports

The DH+ versions of the PanelView terminals have a DH+ port and an RS-232 port.

Use the DH+ port to:

- communicate with a PLC-5 controller on the Allen-Bradley DH+ link via the processor's DH+ port.
- communicate with an SLC 5/04 controller (Channel 0 port) on the Allen-Bradley DH+ link via the processor's DH+ port.

Use the RS-232 port to:

- transfer PanelView applications between a computer and the DH+ terminal using a direct connection.
- connect a printer. For connection details, see the last section in this chapter.

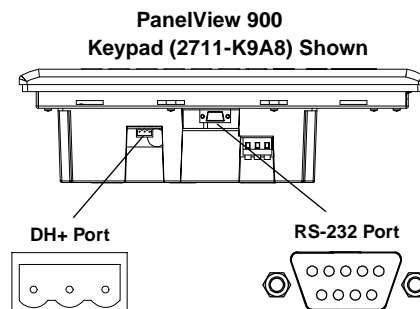
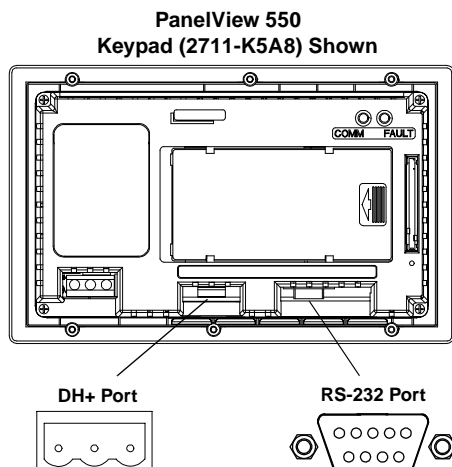

Typical DH+ System Configuration

For more information on the Allen-Bradley DH+ link, refer to:

- 1785-5.7 Enhanced PLC-5 Programmable Controllers Installation Instructions
- 1770-6.2.2 Data Highway/Data Highway Plus/Data Highway II/Data Highway 485 Cable Installation Manual.

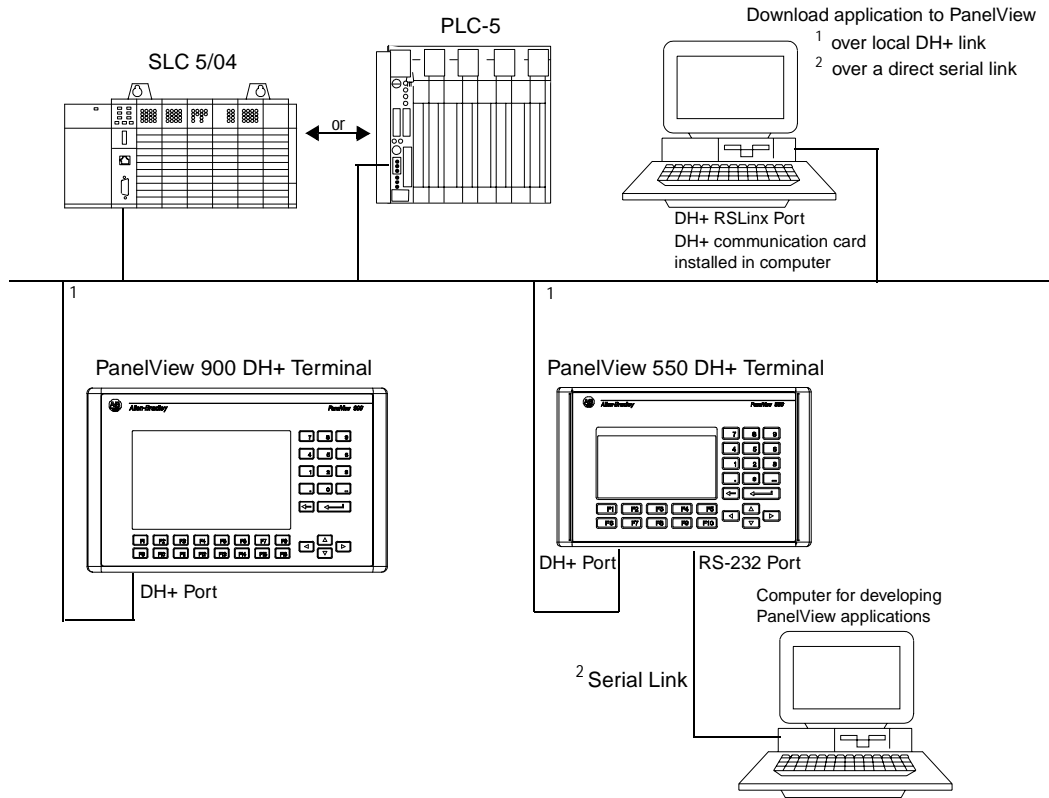

Making DH+ Connections

Use the Belden 9463 twin axial cable (1770-CD) to connect a DH+ PanelView terminal to the DH+ link.

You can connect a DH+ link in 2 ways:

- trunk line/drop line - from the drop line to the connector screw terminals on the DH+ connectors of the processor
- daisy chain - to the connector screw terminals on the DH+ connectors on the processor

Follow these guidelines when installing DH+ communication links:

- do not exceed these cable lengths:
 - trunk line-cable length: 3,048 m (10,000 cable ft)
 - drop-cable length: 30.4 m (100 cable-ft)
- do not connect more than 64 stations on a single DH+ link

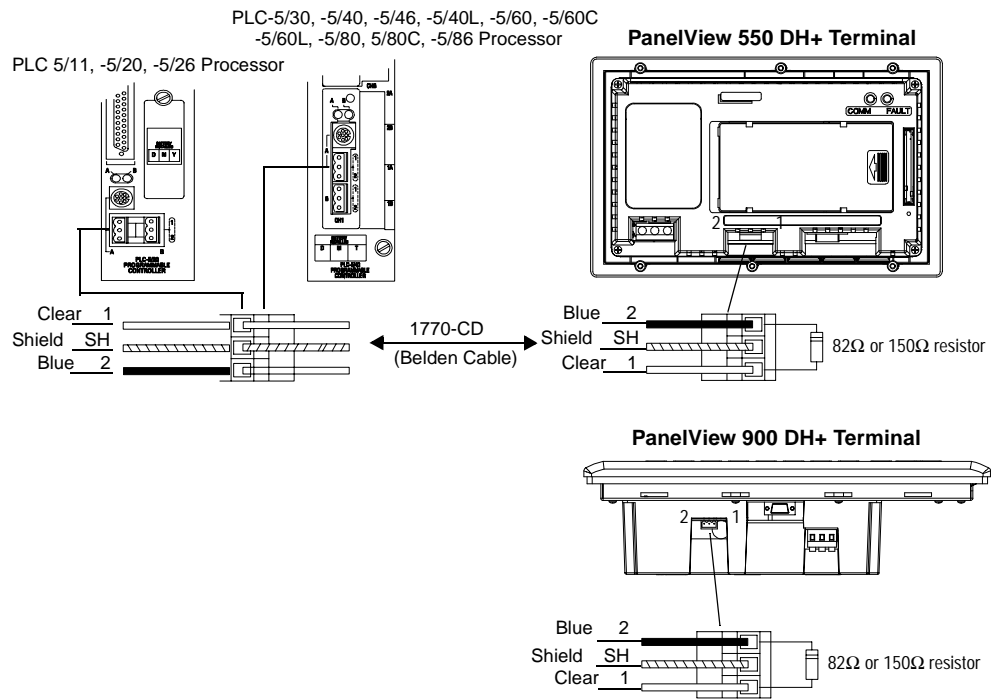

RS-232 Terminal Connections

This section describes connections for the RS-232 PanelView terminals including:

- RS-232 ports
- connecting to Channel 0 of an SLC 5/03, 5/04, 5/05 Controller (point-to-point)
- connecting to a MicroLogix Controller
- connecting a computer
- connecting to a DH+ link

RS-232 Terminal Ports

RS-232 versions of the PanelView terminals with catalog numbers ending in 5 have a single RS-232 communications port. Terminals with catalog numbers ending in 9 have an RS-232 communications port and an RS-232 printer port.

Use the RS-232 communications port to:

- communicate with a single SLC 5/03, 5/04, or 5/05 controller (Channel 0 port) using point-to-point communications
- download/upload PanelView applications

Use the RS-232 printer port to:

- connect a printer that supports the IBM enhanced character set. For connection details, see the last section in this chapter.

The RS-232 communications port and the printer port are reversed on the PanelView 550 touch screen terminals.

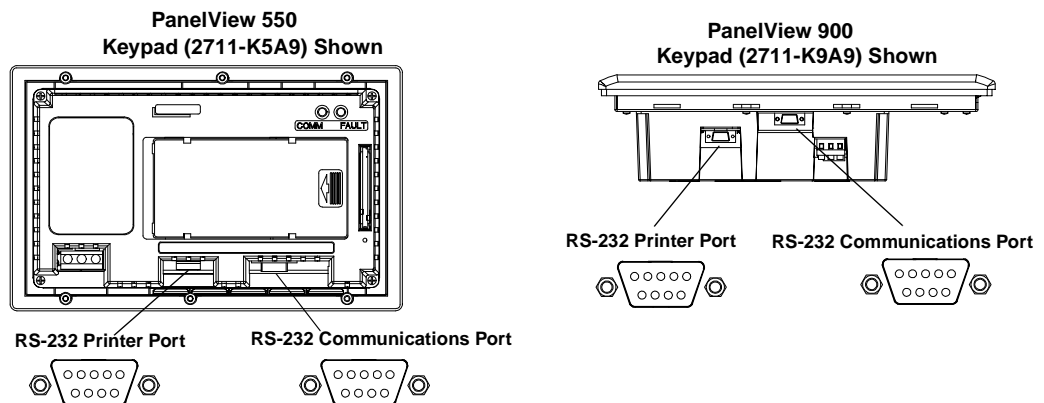

Connecting to an SLC 5/03, 5/04, 5/05 Controller (Point-to-Point)

This section shows how to connect an SLC-5/03, 5/04 or 5/05 controller to the RS-232 PanelView terminal for point-to-point communications. On terminals with two ports, use the RS-232 Communications Port.

Use one of these cables:

- 5 meter (16.4 foot) Catalog No. 2711-NC13
- 10 meter (32.7 foot) Catalog No. 2711-NC14
- 3 meter (10 foot) Catalog No. 2706-NC13

**PanelView 900
Touch Screen (2711-T9A5) Shown**

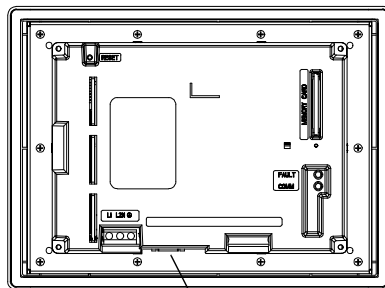

RS-232 Communications Port

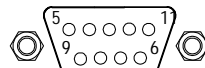

To PanelView Terminal
9-pin, Male, D-Shell Connector

Cable, Catalog No. 2711-NC13
Cable, Catalog No. 2711-NC14
Cable, Catalog No. 2706-NC13

SLC 5/03, 5/04, 5/05

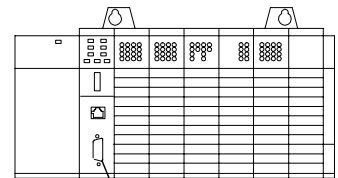

**Channel 0 Port
RS-232 Connector**

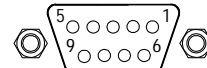

To SLC 5/03, 5/04, 5/05 Channel 0 Port
9-pin, Male, D-Shell Connector

Pin #	Pin #
Required pins	
1	1
Data Out (TXD) 2	2 Data In (RXD)
Data In (RXD) 3	3 Data Out (TXD)
4	4
Signal Common 5	5 Signal Common
6	6
7	7
8	8
9	9

Important: You must configure the Channel 0 Port of the SLC 5/03, 5/04, 5/05 controller for DH-485 communications using the RSLogix 500, or AI500 software.

Connecting to a MicroLogix Controller

This section shows how to connect the RS-232 or DH-485 version of the PanelView terminal to a MicroLogix 1000 controller through an AIC+ Link Coupler.

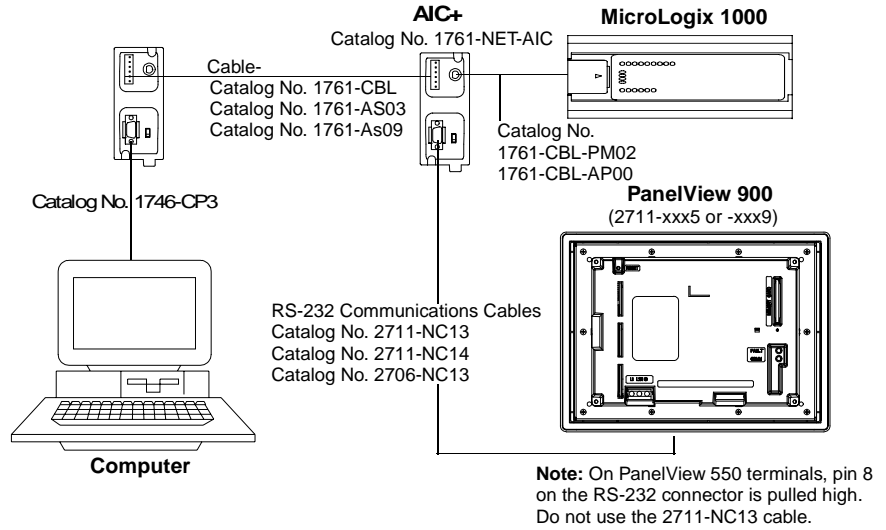

Connecting a Computer

This section shows how to connect a computer to the RS-232 PanelView terminal for transferring applications.

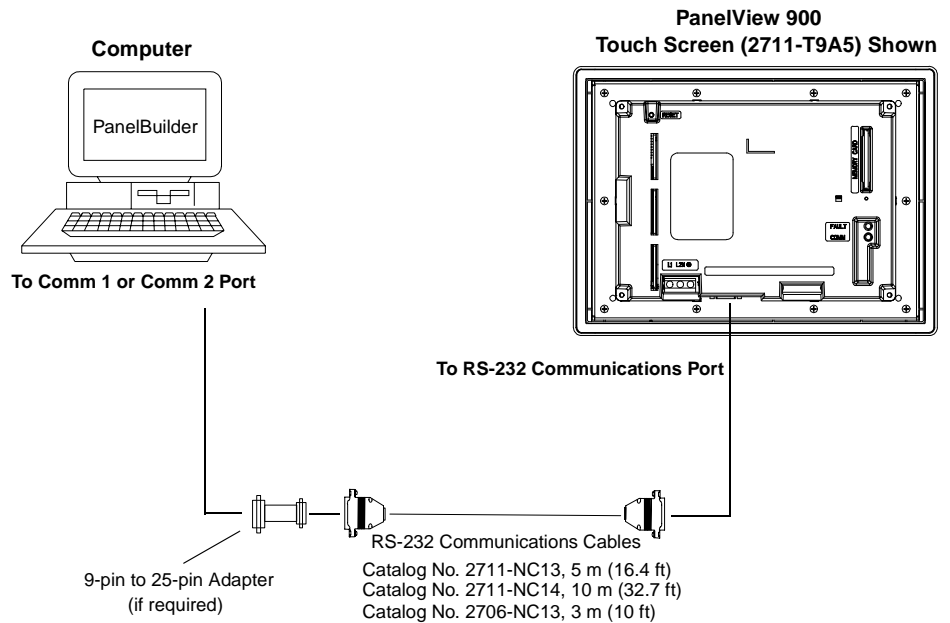

Connecting to a DH+ Link

This section shows connections for transferring applications between a computer on the Allen-Bradley DH+ link and an RS-232 PanelView terminal, through an SLC 5/04 controller.

The RS-232 Communications port on the terminal connects to the CH0 port of the controller using one of the cables listed below.

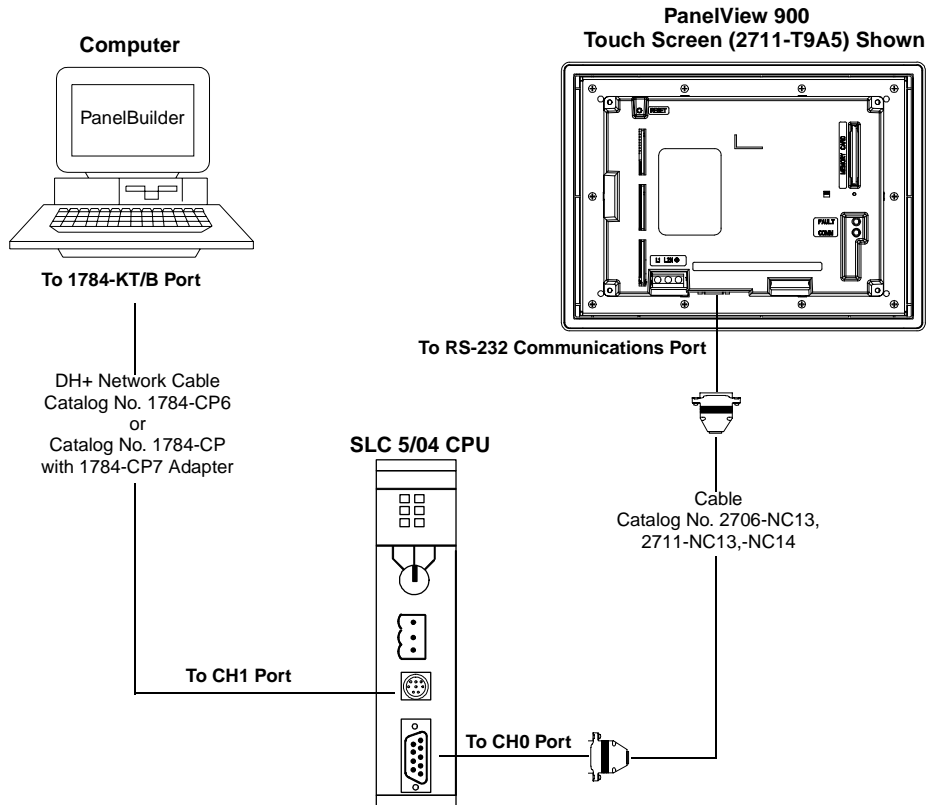

ControlNet Connections

This section describes connections for the ControlNet PanelView terminals including:

- ControlNet Protocol
- Compatible ControlNet Controllers
- ControlNet ports on the PanelView terminal
- Typical ControlNet network
- Making ControlNet connections

Related Information

For more information on ControlNet products, refer to the following publications.

- ControlNet System Overview (Publication 1786-2.9)
- ControlNet System Planning and Installation Manual (1786-6.2.1)
- ControlNet Cable System Component List (AG-2.2)

The Allen-Bradley website (www.ab.com) provides information and product descriptions of ControlNet products. Under the Products and Services heading, select Communications

ControlNet Protocol

The PanelView terminal supports release 1.5 of ControlNet. Unscheduled (peer) addressing of tags is supported. Scheduled (I/O) addressing is not supported.

ControlNet allows a flexible control architecture that can work with multiple processors and up to 99 nodes (via taps) anywhere along the trunk cable of the network. There is no minimum tap separation and you can access the ControlNet network from every node (including adapters).

Compatible ControlNet Controllers

The ControlNet PanelView supports unscheduled PCCC (Programmable Controller Communication Command) messaging with the following controllers:

- PLC-5/20C
- PLC-5/40C
- PLC-5/60C
- PLC-5/80C

ControlNet Terminal Ports

ControlNet versions of the PanelView terminal (catalog numbers ending in 15) have a ControlNet communication port and an RS-232 serial port.

- Use the ControlNet port to connect to devices on a DeviceNet network.
- Use the RS-232 port to transfer applications between a computer and the terminal or to connect a printer.

For details on connecting to the RS-232 port, see the last section in this chapter.

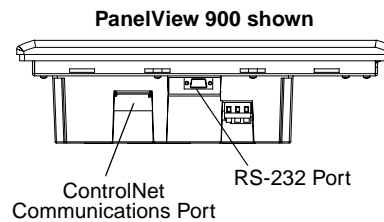

Typical ControlNet Network

Below is a typical ControlNet network with a PanelView terminal installed on a network drop.

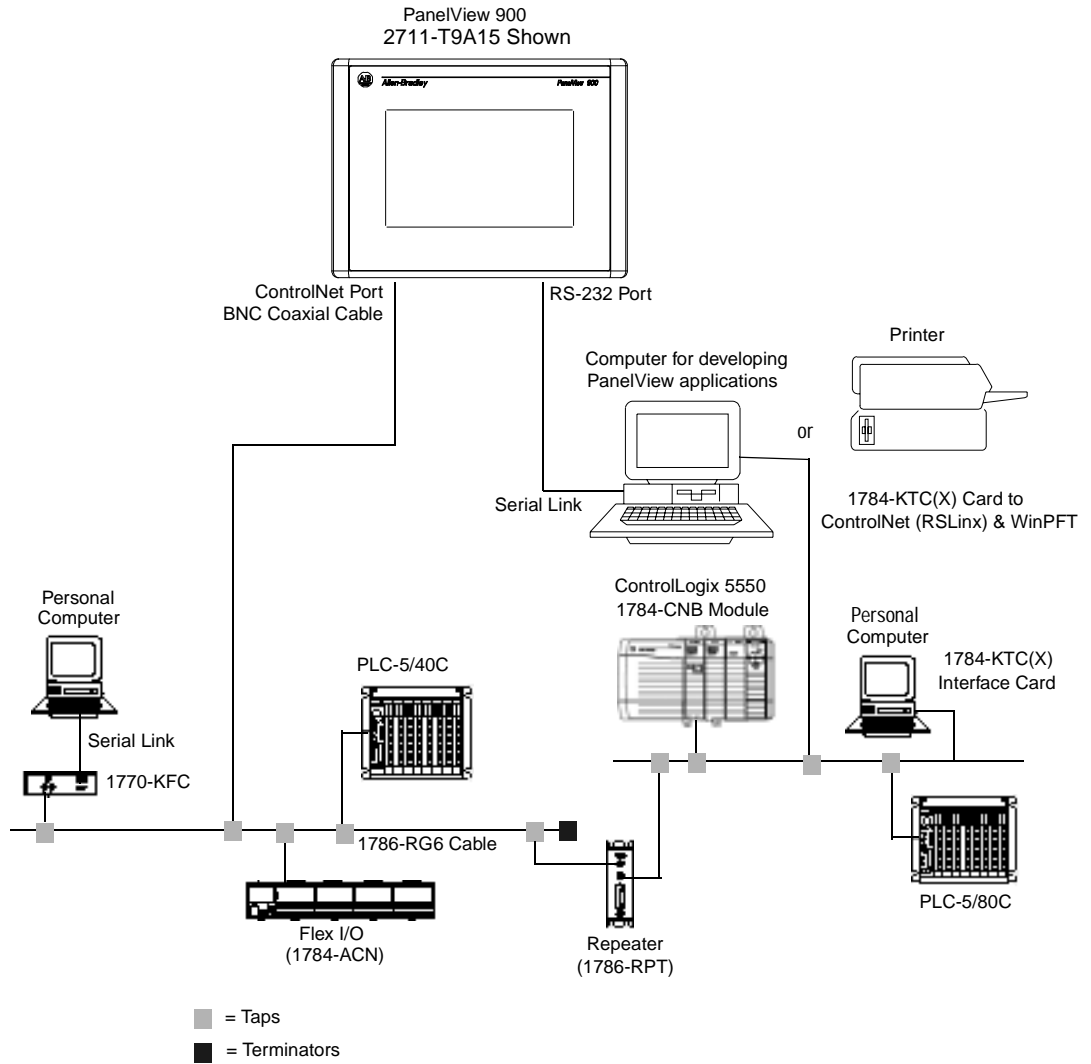

Making ControlNet Connections

Use the pinout information below to connect the PanelView to a ControlNet network.

Important: Follow the ControlNet network layout and design as specified in the ControlNet Cable System Planning and Installation Manual (Publication 1786-6.2).

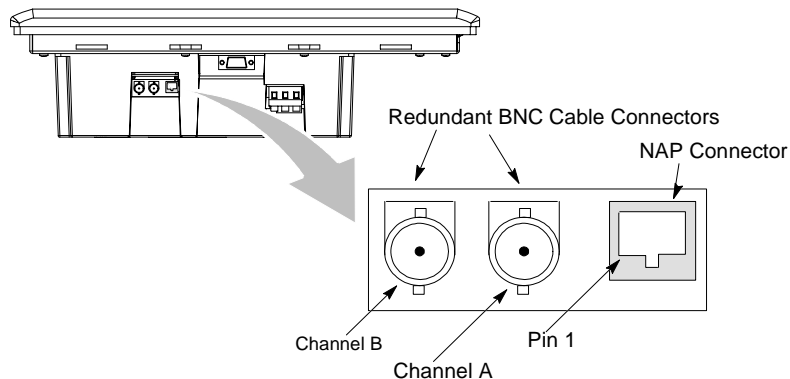

Pin #	NAP Signal
1	Signal Common
2	No Connection
3	TX_H
4	TX_L
5	RX_L
6	RX_H
7	No Connection
8	Signal Common
Shell	Earth Ground

NAP and Redundant Cables

ControlNet cables, taps, connectors. Refer to the ControlNet Cable System Planning and Installation manual (Publication 1786-6.2.1) for descriptions of these components. For information on purchasing these items, refer to the Allen-Bradley ControlNet Cable System Component List (Publication AG-2.2).

Item	Catalog Number
RG-6 quad-shield	1786-RG6
Coax repeater	1786-RPT, -RPTD
Coax taps	1786-TPR, -TPS, -TPYR, -TPYS
Network access cable	1786-CP
Coax tool kit	1786-CTK
Segment terminators	1786-XT
BNC connectors	1786-BNC, -BNCJ, -BNCP, -BNCJ1

Important: Do not connect to a network using both the redundant cable BNC connector and the Network Access Port (NAP).

DeviceNet Terminal Connections

This chapter describes connections for the DeviceNet PanelView terminals including:

- DeviceNet connectors
- typical DeviceNet network

DeviceNet Terminal Ports

The DeviceNet versions of the PanelView terminals (catalog numbers ending in 10) have a DeviceNet port and an RS-232 serial port.

- Use the DeviceNet port to connect to devices on a DeviceNet network.
- Use the RS-232 port to transfer applications between a computer and the terminal or to connect a printer.

For details on connecting to the RS-232 port, see the last section in this chapter.

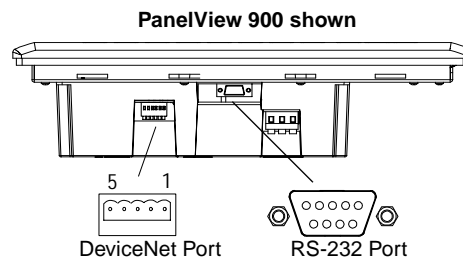

Making DeviceNet Connections

Use one of the cables below to connect the DeviceNet version of the PanelView terminal to a DeviceNet network.

Cable	Publication No.
DeviceNet Cable, 50 meters (164 feet)	1485C-P1A50
DeviceNet Cable, 100 meters (328 feet)	1485C-P1A150
DeviceNet Cable, 150 meters (492 feet)	1485C-P1A300

Important: Refer to DeviceNet Cable System Planning and Installation manual (Publication 1485-6.7.1) for network layout and design information

DeviceNet Terminal Block	Terminal	Signal	Function	Color
	1	COM	Common	Black
	2	CAN_L	Signal Low	Blue
	3	SHIELD	Shield	Uninsulated
	4	CAN_H	Signal High	White
	5	VDC+	Power Supply	Red

Typical DeviceNet Network

Below is a typical DeviceNet network with PanelView terminals installed on 2 of the network drops.

A DeviceNet network requires a 24V dc power supply. DeviceNet power consumption is 24mA - 90mA @24V dc. The PanelView terminal does not receive its power from the network.

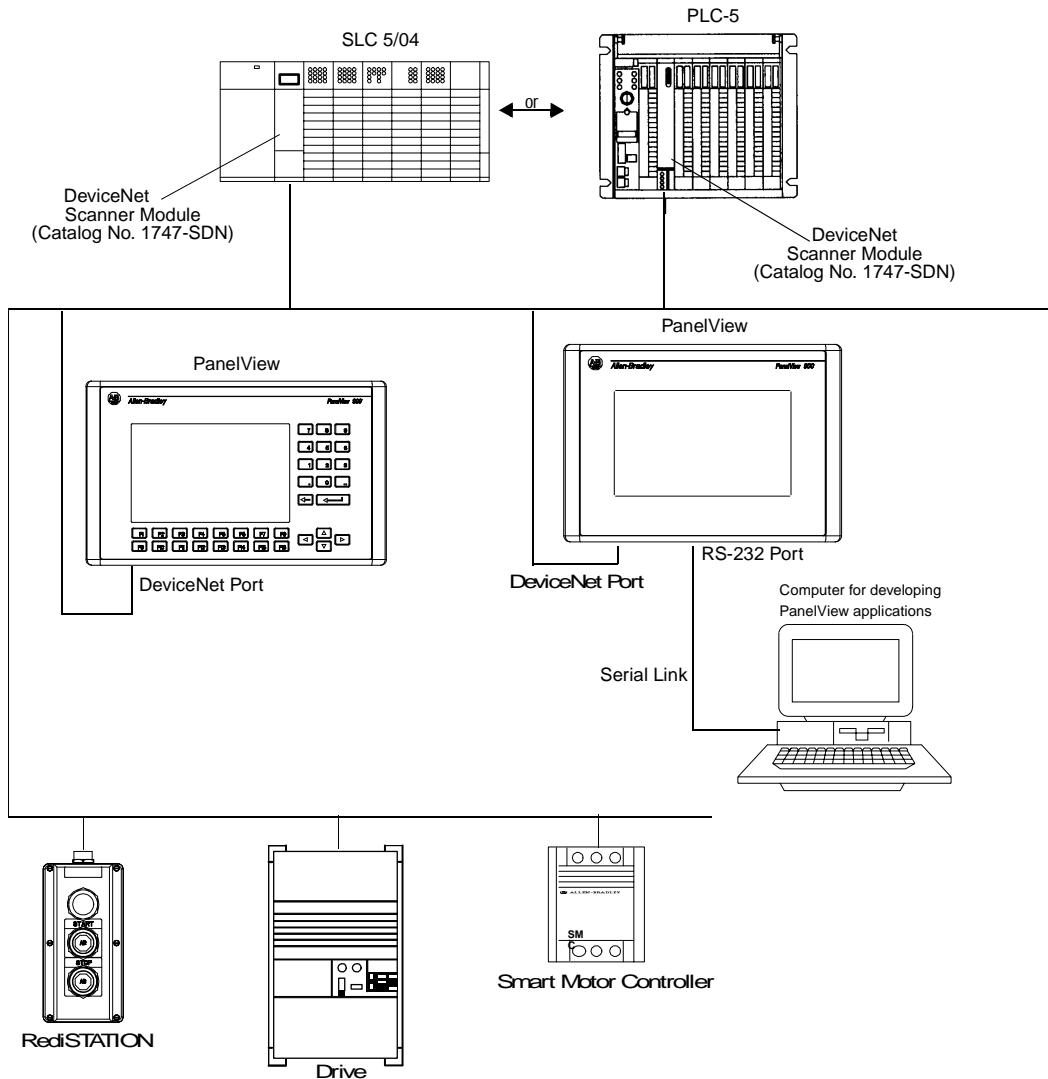

DF1 Terminal Connections

This section describes connections for the DF1 versions of the PanelView terminal including:

- compatible controllers
- DF1 terminal ports
- connecting to a controller (point-to-point)
- using a modem
- connecting to a DeviceNet network

Compatible Controllers

The DF1 terminals support full duplex communications with the following controllers.

- SLC, PLC or MicroLogix 1000 via 1761-Net DNI module
- SLC 5/03, 5/04, or 5/05E (Ethernet version) via Channel 0/DF1 port
- PLC-5/10, 5/12, 5/15, or 5/25 via bridge such as the 1770-KF2, or 1785-KE
- PLC-5/11, 5/20, 5/26, 5/40, 5/46, 5/60, 5/80 via Channel 0/DF1 port
- Ethernet versions of the PLC-5/20E, 5/40E, 5/80E, SLC 5/05E via Channel 0/DF1 port
- ControlNet versions of the PLC-5/20C, 5/40C, 5/60C, 5/80C via Channel 0/DF1 port

DF1 Terminal Ports

The DF1 versions of the PanelView terminals have a DF1 (Full Duplex) communications port and an RS-232 serial port.

- Use the DF1 port to communicate with a logic controller using DF1 full duplex communications.
- Use the RS-232 serial port to transfer applications between a computer and the terminal or to connect a printer. For connection details, see the last section in this chapter.

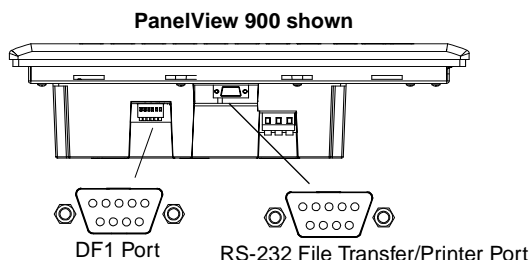

DF1/RS-232 Port Connector

The DF1 port on the PanelView terminal is a 9-pin, male, RS-232 connector. The table below shows the pinout descriptions for this port and how these pins map to the DF1 ports on the controllers.

DF1 Port 9-pin	DF1 Port Signal Name	Signal Description	SLC 9-pin	PLC 25-pin	MicroLogix/ DNI 8-pin DIN
1		No Connection			
2	RXD	Receive Data	2	2	4
3	TXD	Transmit Data	3	3	7
4	DTR	Data Terminal Ready	4	20	
5	SG	Signal Ground	5	7	2
6	DSR	Data Set Ready	6	6	
7	RTS	Request to Send	7	4	
8	CTS	Clear to Send	8	5	
9		No Connection			

The maximum cable length for DF1/full duplex communications is 15.24 meters (50 feet).

Connecting to a MicroLogix 1000

The following shows a point-to-point connection between the DF1 port of the PanelView terminal and a MicroLogix 1000.

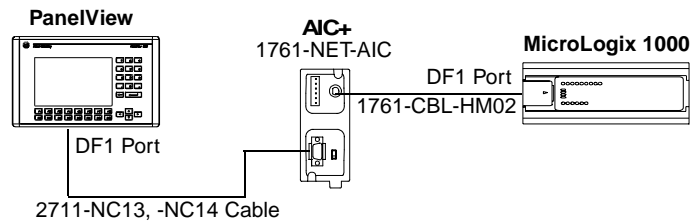

The 1761-NET-AIC is used only with the MicroLogix and eliminates grounding level differences between the controller and PanelView.

Connecting to an SLC or PLC

The following shows a point-to-point connection between the DF1 port of the PanelView terminal and an SLC or PLC controller.

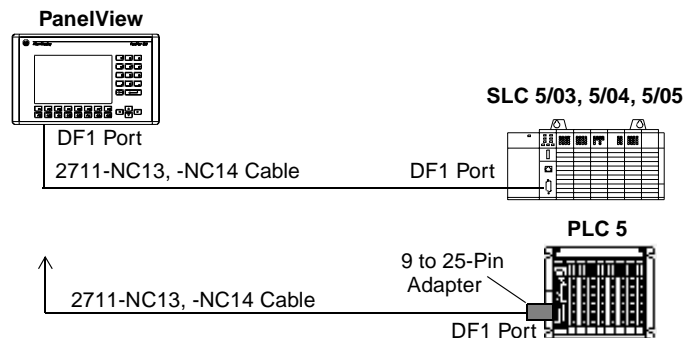

Use an optical isolator or equivalent when grounding level differences exist between the controller or modem and the PanelView.

Using a Modem

Wire or radio modem communications is possible between a DF1 terminal and controller. Each modem must support full duplex communications. Refer to your modem user manual for details on settings and configuration.

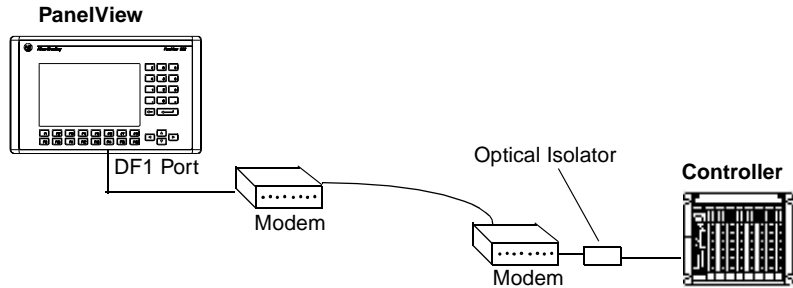

Connecting to a DeviceNet Network

The following illustration shows a DF1 PanelView terminal connected to a single controller (MicroLogix, SLC or PLC) in a DeviceNet network.

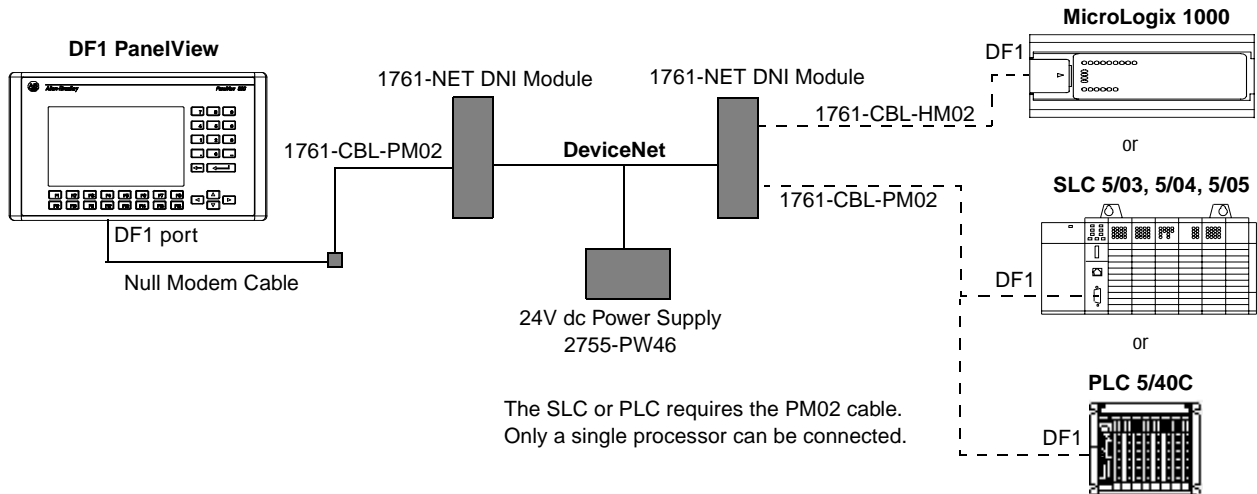

Constructing a Null Modem Cable

To construct a null modem cable, refer to the following pinout:

9-pin			25-pin	9-pin
3	TXD	↔	TXD	3
2	RXD	↔	RXD	2
5	GND	↔	GND	7
1	CD	↔	CD	8
4	DTR	↔	DTR	20
6	DSR	↔	DSR	6
8	CTS	↔	CTS	5
7	RTS	↔	RTS	4

Connecting a Computer or Printer to the Terminal

Most of the PanelView terminals have an RS-232 serial port you can use to:

- download/upload applications over a serial link
- and/or connect a printer that supports the IBM enhanced character set

The illustration below shows how to make these connections.

Communication parameters for the RS-232 port are set on the Printer Setup screen of the Configuration Mode menu.

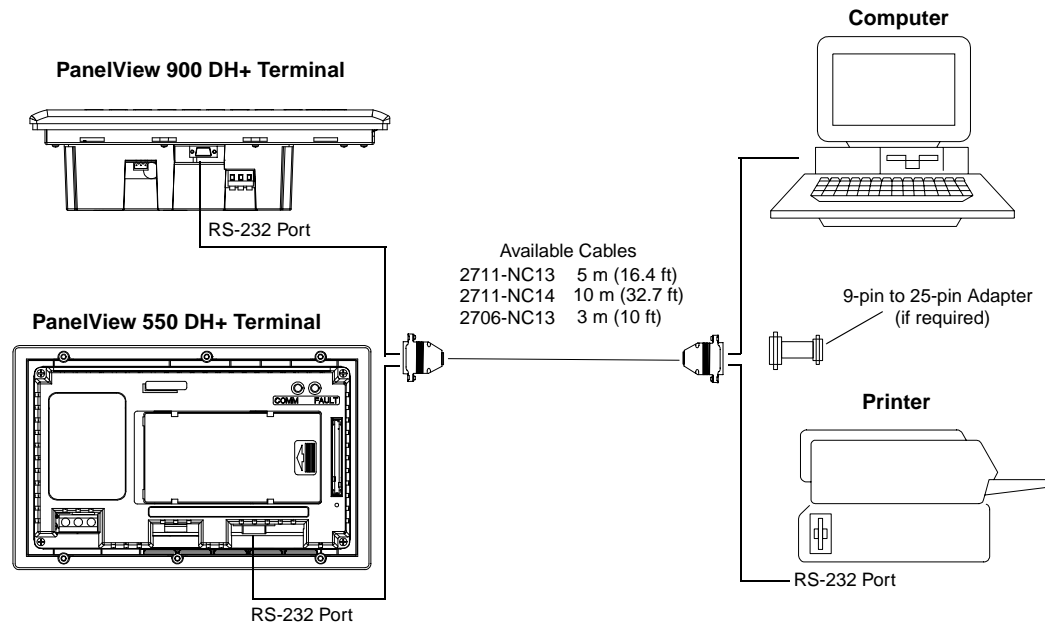

PV550 Printer Port

9-pin male

- 1 NC
- 2 TXD or TX1 (Data Transmit)
- 3 RXD or RX1 (Data Receive)
- 4 NC
- 5 GND
- 6 DSR (pulled high to +12V)
- 7 NC
- 8 CTS (pulled high to +12V)
- 9 NC

PV600/900/1000/1400 Printer Port

9-pin male

- 1 NC
- 2 TXD or TX1 (Data Transmit)
- 3 RXD or RX1 (Data Receive)
- 4 NC
- 5 GND
- 6 DSR (pulled high to +12V)
- 7 RTS or RX2 (Data Receive)
- 8 CTS or TX2 (Data Transmit)
- 9 NC

Printer/Computer Port

9-pin female

- 1 DCD
- 2 RXD (Data Receive)
- 3 TXD (Data Transmit)
- 4 DTR
- 5 GND
- 6 DSR
- 7 RTS
- 8 CTS
- 9 NC

Troubleshooting and Maintenance

Chapter Objectives

This chapter tells how to isolate and correct common operating problems and perform routine maintenance tasks.

- equipment required
- using troubleshooting chart
- LED indicators
- cleaning display window
- replacing clock module
- replacing backlight

Equipment Required

Other than verifying that the correct power source is connected to the terminal (use a voltmeter), no electronic diagnostic equipment is required for troubleshooting.

Using the Troubleshooting Chart

The following pages provide a troubleshooting chart for the terminal. This chart lists the most common operating problems, causes, and steps to correct them.



ATTENTION: The PanelView terminals contain hazardous voltages. Do not insert objects or let objects fall into the terminal through ventilation slots. Always disconnect power when checking wiring connections. Failure to take adequate precautions may result in electrical shock.

Troubleshooting Chart

Problem	Probable Cause(s)	Corrective Action(s)
Terminal does not power up.	Improper connection to power source.	Verify correct voltage at power terminals on the back of the terminal.
No communications with SLC or PLC controller.	<ol style="list-style-type: none"> 1. Communications (COMM) fault. 2. Baud rates not set properly. 3. Controller is not in run mode. 4. Terminal node and maximum node numbers are not set correctly. 5. Controller fault. 	<ol style="list-style-type: none"> 1. Check status of COMM LED. Verify cable connections using cable diagrams in Chapters 6 - 9. 2. Verify that terminal and controller are set at the same baud rate. 3. Place controller in run mode. 4. Verify node number settings. 5. Refer to controller user manual.
No communications with PLC but COMM LED is green.	<ol style="list-style-type: none"> 1. PanelView is trying to communicate with a controller at a different address. 2. The inhibit bit is set as the default on the Channel Status Screen in the PLC. 	<ol style="list-style-type: none"> 1. Verify address of the controller. 2. Change setting of the inhibit bit.
No communications with computer.	<ol style="list-style-type: none"> 1. Communications (COMM) fault. 2. No SLC, network, or power supply connection at terminal's DH-485 port. 3. Baud rates not set correctly. 4. Terminal node and maximum node numbers are not set correctly. 5. Computer fault. 6. Communication driver not properly loaded. 7. Printer port is enabled. 	<ol style="list-style-type: none"> 1. Check status of COMM LED. Verify cable connections using cable diagrams in Chapter 10. 2. Personal Computer Interface Converter (PIC) receives power from DH-485 connection. Verify that the terminal is connected to an SLC, network, or wallmount power supply as shown in Chapter 6. 3. Verify that terminal and computer are set at the correct baud rate. 4. Verify node number settings. 5. Refer to user manual for computer. 6. Refer to RSLinx online help or manual. 7. Disable printing on the Printer Setup screen of the Configuration Mode menu.
Clock Module Battery Low message is displayed.	Clock module needs replacing.	Replace clock module as described in instructions provided with clock module kit.
Cannot transfer application from memory card.	<ol style="list-style-type: none"> 1. Memory card is not properly installed. 2. Application is too large for terminal memory. 3. Data checksum is incorrect. 4. Invalid file format. 	<ol style="list-style-type: none"> 1. Verify correct installation. 2. Reduce size of application file. 3. Check that memory card is properly seated. Application may be corrupt. 4. Verify file format (.PVA) being transferred.

Problem	Probable Cause(s)	Corrective Action(s)
Cannot transfer application to memory card.	<ol style="list-style-type: none"> 1. Memory card is not properly installed. 2. Memory card is write protected.¹ 3. File currently exists on memory card.¹ 4. Application file is too large, not enough space on memory card. 5. Invalid memory card format.¹ 6. Data checksum is incorrect. 7. Application does not exist.¹ 	<ol style="list-style-type: none"> 1. Verify correct installation. 2. Change memory card protection switch. 3. Erase and reformat card. 4. Reduce size of application file or erase/format memory card. 5. Replace or reformat memory card. If problem continues, try another card. 6. Check that card is installed correctly. If problem continues, try another card. 7. Check the Terminal Info screen to verify that an application exists.
Screen objects do not function. ¹	Communications problem.	Check status of COMM LED. See problem 'No communications with SLC or PLC controller' for more information.
Application file name appears as ***** on Terminal Info screen.	<ol style="list-style-type: none"> 1. Application is invalid. 2. Application is unusable because of error. 	<ol style="list-style-type: none"> 1. Download application and try again. 2. Download new application.
Area on color screen appears dark.	One of the backlight tubes has burnt out.	Replace color backlight.
Screen objects are not visible.	<ol style="list-style-type: none"> 1. Correct power is not applied. 2. Contrast or intensity is not set correctly. 3. Terminal is in screen saver mode. 4. PV550 backlight lamp is not on. 5. Terminal's backlight is burnt out. 	<ol style="list-style-type: none"> 1. Verify power connections. 2. Access Screen Setup on the Configuration Mode menu and adjust the contrast. On keypad terminals, press the left and right arrow keys simultaneously, then press [F9] or [F15]. 3. Access Screen Setup on the Configuration Mode menu to see if terminal is set for screen saver mode. 4. Access Screen Setup on the Configuration Mode menu and turn on backlight. 5. Replace backlight.
Values do not update on display but appear as asterisks ****	<ol style="list-style-type: none"> 1. Terminal is not communicating with controller. 2. Value is invalid or exceeds the field width defined for the object. 	<ol style="list-style-type: none"> 1. Check status of COMM LED. Refer to problem 'No communication with SLC or PLC controller' for more details. 2. Change the field width for the object.

¹ Terminal displays a warning message with instructions if these errors occur.

LED Indicators

Use the COMM and Fault LED indicators to isolate operating problems. The illustration below shows the location of these indicators.

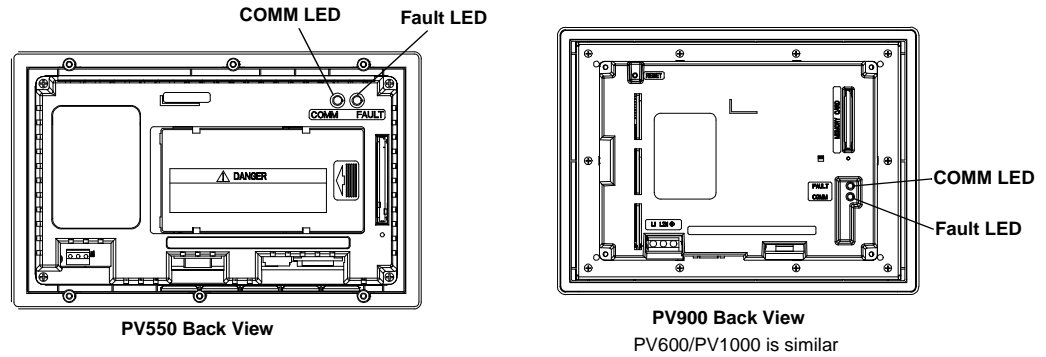

DH-485 and DH+ LED Indications

LED	State	Indicates
Comm ¹	On (steady green)	Normal operating state (no communication faults). Good hardware connection.
	Off (power applied)	Fault detected <ul style="list-style-type: none"> • Make sure controller is run mode • Verify baud settings of terminal and controller • Verify proper terminal to controller connections
	Blinking	No communications established
Fault	Off	Normal operating state
	On (steady red)	Fault detected. Cycle power to the terminal. If the fault still exists, the terminal requires servicing.
	Flashing	Hardware is functioning but no application is loaded or the current application is corrupt.

¹ Comm LED stays on until powerup self-tests are complete.

Remote I/O LED Indications

LED	State	Indicates
Comm ¹	On (steady green)	Normal operating state (no communication faults)
	Off (power applied)	Communications not functioning <ul style="list-style-type: none"> • Verify that baud rate and rack settings match the PLC settings • Verify proper terminal to controller connections • Verify that the PLC enables Remote I/O communications
	Blinking	No communications established. PLC is in program mode
Fault	Off	Normal operating state
	On (steady red)	Fault detected. Cycle power to the terminal. If the fault still exists, the terminal requires servicing.
	Flashing	Hardware is functioning but no application is loaded or the current application is corrupt.

¹ Comm LED stays on until powerup self-tests are complete

Cleaning the Display Window

To clean the display window:



ATTENTION: Use of abrasive cleansers or solvents may damage the window. Do not scrub or use brushes.

1. Disconnect power from the terminal at the power source.
2. Use a clean sponge or a soft cloth to clean the display with a mild soap or detergent.
3. Dry the display with a chamois or moist cellulose sponge to avoid water spots.

Removing Paint and Grease

Remove fresh paint splashes and grease before drying by rubbing lightly with isopropyl alcohol (70% concentration). Afterward, provide a final wash using a mild soap or detergent solution. Rinse with clean water.

Equipment Hose Downs

Be aware that screen objects on touch cell terminals may activate during equipment hose downs.



ATTENTION: Because touch terminals have sensitive touch cell regions, it is possible for screen objects to activate during equipment hose downs.

Replacing the Clock Module

The Real-Time Clock (RTC) module contains a lithium battery used only by the real-time clock. The battery is not used for application backup or input retention. The clock module has a typical life expectancy of 7 years.

The clock module replacement kits for the PanelView terminals are listed in Chapter 1 under *Replacement Parts*. Replacement instructions are provided with the kits.



ATTENTION: The clock module contains lithium. Do not attempt to dispose of the module in a fire or incinerator. Doing so may cause the clock module to explode. Follow disposal regulations in your area for lithium battery disposal.

Replacing the Backlight

Replacement backlights are available for the PanelView terminals. See *Replacement Parts* in Chapter 1 for the catalog numbers. Replacement instructions are provided with the kits.

Specifications

PanelView 550 Terminals

Electrical

AC Power	
Supply Voltage Limits	85 to 264V ac, 47 to 63 Hz
Power Consumption	45 VA maximum
DC Power	
Supply Voltage Limits	18 to 30V dc (24V dc nominal)
Power Consumption	18 Watts, max. (0.75A @ 24V dc)
Supply Voltage Limits (touch screen only)	18 to 32V dc (24V dc nominal)
Power Consumption (touch screen only)	18 Watts, max. (0.75A @ 24V dc)

Mechanical

Enclosure	NEMA Type 12/13, 4X (Indoor use only), IP54, IP65
LED Indicators	
COMM	Green
Fault	Red
Weight	
Keypad, Keypad & Touch	1.2 kg (2.7 lbs)
Touch Screen	.93 kg (2.1 lbs)
Dimensions- Keypad, Keypad & Touch	
mm	167 (H) x 266 (W) x 106 (D)
Inches	6.57 (H) x 10.47 (W) x 4.17 (D)
Dimensions- Touch Screen	
mm	150 (H) x 183 (W) x 82 (D)
inches	5.92 (H) x 7.21 (W) x 3.20 (D)
Installed Depth- Keypad, Keypad & Touch	86 mm (3.39 inches) 118 mm (4.64 inches) with memory card retainer 207 mm (8.15 inches) with memory card retainer and clearance to insert and remove memory card
Installed Depth- Touch Screen	64 mm (2.54 inches) 109 mm (4.30 inches) with memory card retainer 207 mm (8.15 inches) with memory card retainer and clearance to insert and remove memory card

Display

Type	Liquid Crystal Display (LCD)
Size	120 x 60 mm (4.75 x 2.38 in.)
Pixels	256 x 128
Touch Cells	128 (16 columns x 8 rows)
Touch Cell Size	16 x 16 pixels

Terminal Memory

PV550 (Series E or later) or PV550T (Series A or later) Total Application Flash Memory	240K bytes (application screens)
PV550 (Prior to Series E) Total Application Flash Memory	112K bytes (application screens)

Environment

Operating Temperature	0 to 55° C (32 to 131° F)
Storage Temperature	-20 to 70° C (-4 to 158° F)
Relative Humidity (non-condensing)	5 to 95% at 0 to 30° C (32 to 86° F) 5 to 75% at 31 to 40° C (88 to 104° F) 5 to 50% at 41 to 55° C (106 to 131° F)
Heat Dissipation	20 Watts (69 BTU/HR) for AC Power or DC Power
Impulse Shock (operating/non-operating)	30G/50G
Vibration (operating)	2G up to 2,000 Hz

Character Sizes (Pixel size = 0.47 x 0.47 mm)

Size in Pixels (width x height)	Characters/Row	Maximum Rows	Dimensions in mm Width x Height
6 x 8	40	16	2.2 x 3.2
6 x 16	20	16	3.8 x 5.6
6 x 24	13	16	3.8 x 8.4
12 x 8	40	8	7.6 x 2.8
12 x 16	20	8	7.6 x 5.6
12 x 24	13	8	7.6 x 8.4
18 x 8	40	5	11.2 x 2.8
18 x 16	20	5	11.2 x 5.6
18 x 24	13	5	11.2 x 8.4

PanelView 600 Color Terminals**Electrical**

AC Power Supply Voltage Limits Power Consumption	85 to 264V ac, 43 to 63 Hz 60 VA maximum
DC Power Supply Voltage Limits Power Consumption	18 to 32V dc (24V dc nominal) 34 Watts max. (1.4A @ 24V dc)

Mechanical

Enclosure	NEMA Type 12/13, 4X (Indoor use only), IP54, IP65
LED Indicators COMM Fault	Green Red
Weight	2 kg (4.4 lbs)
Dimensions mm inches	192 (H) x 290 (W) x 116 (D) 7.55 (H) x 11.40 (W) x 4.57 (D)
Installed Depth	99 mm (3.89 inches) 131 mm (5.14 inches) with memory card retainer 220 mm (8.65 inches) with memory card retainer and clearance to insert and remove memory card

Display

Type	Active Matrix Thin-Film Resistor (TFT) with Cold Cathode Fluorescent (CCF) Backlight
Size	115 x 86 mm (4.54 x 3.4 in.)
Pixels	320 x 234
Touch Cells	128 (16 columns x 8 rows)
Touch Cell Size	20 x 29 pixels

Terminal Memory

Total Application Flash Memory	240K bytes (application screens)
--------------------------------	----------------------------------

Environment

Operating Temperature	0 to 55° C (32 to 131° F)
Storage Temperature	-25 to 70° C (-13 to 158° F)
Relative Humidity (non-condensing)	5 to 95% at 0 to 55° C (32 to 131° F)
Heat Dissipation	32 Watts (107 BTU/HR) for AC or DC Power
Impulse Shock (operating/non-operating)	30G/50G
Vibration (operating)	2G up to 2,000 Hz

Terminal Memory

Total Application Flash Memory	240K bytes (application screens)
--------------------------------	----------------------------------

Environment

Operating Temperature	0 to 55° C (32 to 131° F)
Storage Temperature	-25 to 70° C (-13 to 158° F)
Relative Humidity (non-condensing)	5 to 95% at 0 to 55° C (32 to 131° F)
Heat Dissipation	32 Watts (107 BTU/HR) for AC or DC Power
Impulse Shock (operating/non-operating)	30G/50G
Vibration (operating)	2G up to 2,000 Hz

Character Sizes (Pixel size = 0.36 x 0.37 mm)

Size in Pixels (width x height)	Characters/Row	Maximum Rows	Dimensions in mm Width x Height
6 x 9	52	25	2.9 x 5.9
8 x 16	39	14	2.9 x 5.9
8 x 24	39	9	2.9 x 8.9
16 x 24	19	9	5.8 x 8.9
24 x 32	13	7	8.6 x 11.8
32x 40	9	5	11.5 x 14.8

PanelView 900 Monochrome and Color Terminals

Electrical

AC Power - PV900M and PV900C Supply Voltage Limits Power Consumption	85 to 264V ac, 47 to 63 Hz 110 VA maximum
DC Power - PV900M Supply Voltage Limits Power Consumption	18 to 30 V dc (24V dc nominal) 58 Watts max. (2.5A @ 24V dc)
DC Power - PV900C Supply Voltage Limits Power Consumption	18 to 32 V dc (24V dc nominal) 50 Watts max. (2.1A @ 24V dc)

Mechanical

Enclosure	NEMA Type 12/13, 4X (Indoor use only) IP54, IP65
LED Indicators COMM Fault	Green Red
Weight - PV900M Keypad Touch Screen	3.14 kg (4.4 lbs) 2.91 kg (6.4 lbs)
Weight - PV900C Keypad Touch Screen	3.18 kg (7.0 lbs) 2.95 kg (6.5 lbs)
Dimensions - PV900M/900C Keypad mm inches	249 (H) x 406 (W) x 112 (D) 9.80 (H) x 15.97 (W) x 4.40 (D)
Dimensions - PV900M/900C Touch Screen mm inches	249 (H) x 336 (W) x 112 (D) 9.80 (H) x 13.24 (W) x 4.40 (D)
Installed Depth - PV900M	97 mm (3.81 inches) 129 mm (5.06 inches) with memory card retainer 220 mm (8.65 inches) with memory card retainer and clearance to insert and remove memory card
Installed Depth - PV900C	99 mm (3.89 inches) 131 mm (5.14 inches) with memory card retainer 222 mm (8.73 inches) with memory card retainer and clearance to insert and remove memory card

Display

PV900M	
Type	AC Gas Plasma
Size	210 x 131 mm (8.27 x 5.17 in.)
Pixels	640 x 400
Touch Cells	384 (24 columns x 16 rows)
Touch Cell Size	26 x 25 pixels

PV900C	
Type	Active Matrix Thin-Film Resistor (TFT) with Cold Cathode Fluorescent (CCF) Backlight
Size	171 x 130 mm (6.73 x 5.12 in.)
Pixels	640 x 480
Touch Cells	384 (24 columns x 16 rows)
Touch Cell Size	26 x 30 pixels

Terminal Memory

PV900M (prior to Series E) Total Application Flash Memory	240K bytes (application screens)
PV900M (Series E, firmware 3.0 or later), PV900C Total Application Flash Memory	1008K bytes (application screens)

Environment

PV900M	
Operating Temperature	0 to 55° C (32 to 131° F)
Storage Temperature	-25 to 70° C (-13 to 158° F)
Relative Humidity (non-condensing)	5 to 85% at 0 to 30° C (32 to 86° F)
Heat Dissipation	50 Watts (165 BTU/HR) for AC Power or DC Power
Impulse Shock (operating/non-operating)	15G/30G
Vibration (operating)	1G up to 2,000 Hz

PV900C	
Operating Temperature	0 to 55° C (32 to 131° F)
Storage Temperature	-25 to 70° C (-13 to 158° F)
Relative Humidity (non-condensing)	5 to 95% at 0 to 55° C (32 to 131° F)
Heat Dissipation	39 Watts (133 BTU/HR)
Impulse Shock (operating/non-operating)	15G/30G
Vibration (operating)	1G up to 2,000 Hz

Character Sizes - PV900M (Pixel size = 0.33 x 0.33 mm)

Size in Pixels (width x height)	Characters/Row	Maximum Rows	Dimensions in mm Width x Height
8 x 16	79	24	2.6 x 5.3
8 x 24	79	16	2.6 x 7.9
16 x 24	39	16	5.3 x 7.9
24 x 32	26	12	7.9 x 10.6
32x 40	19	9	10.6 x 13.2

Character Sizes - PV900C (Pixel size = 0.27 x 0.27 mm)

Size in Pixels (width x height)	Characters/Row	Maximum Rows	Dimensions in mm Width x Height
8 x 16	79	24	2.2 x 4.3
8 x 24	79	19	2.2 x 6.5
16 x 24	39	19	4.3 x 6.5
24 x 32	26	14	6.5 x 8.6
32x 40	19	11	8.6 x 10.8

PanelView 1000 Grayscale and Color Terminals

Electrical

AC Power - PV1000G and PV1000C Supply Voltage Limits Power Consumption	85 to 264V ac, 47 to 63 Hz 100 VA maximum
DC Power - PV1000G Supply Voltage Limits Power Consumption	18 to 32 V dc (24V dc nominal) 40 Watts max. (1.7A @ 24V dc)
DC Power - PV1000C Supply Voltage Limits Power Consumption	18 to 32 V dc (24V dc nominal) 50 Watts max. (2.1A @ 24V dc)

Mechanical

Enclosure	NEMA Type 12/13, 4X (Indoor use only) IP54, IP65
LED Indicators COMM Fault	Green Red
Weight - PV1000G Keypad Touch	3.27 kg (7.2 lbs) 3.18 kg (7.0 lbs)
Weight - PV1000C Keypad Touch Screen	3.72 kg (8.2 lbs) 3.58 kg (7.9 lbs)
Dimensions-PV1000G/1000C Keypad mm inches	282 (H) x 423 (W) x 112 (D) 11.11 (H) x 16.64 (W) x 4.40 (D)
Dimensions - PV1000G/1000C Touch Screen mm inches	282 (H) x 370 (W) x 112 (D) 11.11 (H) x 14.58 (W) x 4.40 (D)
Installed Depth - PV1000G	97 mm (3.81 inches) 129 mm (5.06 inches) with memory card retainer 220 mm (8.65 inches) with memory card retainer and clearance to insert and remove memory card
Installed Depth - PV1000C	99 mm (3.89 inches) 131 mm (5.14 inches) with memory card retainer 222 mm (8.73 inches) with memory card retainer and clearance to insert and remove memory card

Terminal Memory

Total Application Flash Memory	1008K bytes (application screens)
--------------------------------	-----------------------------------

Display

PV1000G	
Type	Electroluminescent
Size	211 x 158 mm (8.3 x 6.2 in.)
Pixels	640 x 480
Touch Cells	384 (24 columns x 16 rows)
Touch Cell Size	26 x 30 pixels
PV1000C	
Type	Active Matrix Thin-Film Resistor (TFT) with Cold Cathode Fluorescent (CCF) Backlight
Size	211 x 158 mm (8.3 x 6.2 in.)
Pixels	640 x 480
Touch Cells	384 (24 columns x 16 rows)
Touch Cell Size	26 x 30 pixels

Environment

Operating Temperature	0 to 55° C (32 to 131° F)
Storage Temperature	-25 to 70° C (-13 to 158° F)
Relative Humidity (non-condensing)	5 to 95% at 0 to 55° C (32 to 131° F)
Heat Dissipation	39 Watts (132 BTU/HR) for Grayscale and Color
Impulse Shock (operating/non-operating)	15G/30G
Vibration (operating)	2G up to 2,000 Hz

Character Sizes - PV1000G and PV1000C (Pixel size = 0.33 x 0.33 mm)

Size in Pixels (width x height)	Characters/Row	Maximum Rows	Dimensions in mm Width x Height
8 x 16	79	24	2.2 x 5.3
8 x 24	79	19	2.6 x 7.9
16 x 24	39	19	5.3 x 7.9
24 x 32	26	14	7.9 x 10.6
32x 40	19	11	10.6 x 13.2

PanelView 1400 Color Terminals

Electrical

AC Power Supply Voltage Limits Power Consumption	85 to 264V ac, 43 to 63 Hz 200 VA maximum
--	--

Mechanical

Enclosure	NEMA Type 12/13, 4X (Indoor use only) IP54, IP65
LED Indicators COMM Fault	Green Red
Weight Keypad Touch Screen	20.3 kg (44.75 lbs) 19.6 kg (43.2 lbs)
Dimensions - PV1400 Keypad mm inches	355 (H) x 483 (W) x 394 (D) 13.97 (H) x 19.0 (W) x 15.53 (D)
Dimensions - PV1400 Touch Screen mm inches	355 (H) x 441 (W) x 394 (D) 13.97 (H) x 17.37 (W) x 15.53 (D)
Installed Depth	370 mm (14.58 inches) 400 mm (15.75 inches) with clearance to insert and remove memory card

Terminal Memory

Total Application Flash Memory	1008K bytes (application screens)
--------------------------------	-----------------------------------

Display

Type	Color CRT
Size	255 x 191 mm (10.0 x 7.5 in.)
Pixels	800 x 600
Touch Cells	384 (24 columns x 16 rows)
Touch Cell Size	33 x 37 pixels

Environment

Operating Temperature	0 to 55° C (32 to 131° F)
Storage Temperature	-40 to 85° C (-40 to 185° F)
Relative Humidity (non-condensing)	5 to 95% at 0 to 55° C (32 to 131° F)
Heat Dissipation	78 Watts (264 BTU/HR)
Impulse Shock (operating/non-operating)	15G/30G
Vibration (operating)	1G up to 2,000 Hz

Character Sizes - PV1400 (Pixel size = 0.32 x 0.32 mm)

Size in Pixels (width x height)	Characters/Row	Maximum Rows	Dimensions in mm Width x Height
8 x 20	99	29	2.5 x 6.4
16 x 24	49	24	5.1 x 7.6
24 x 32	33	18	7.6 x 10.2
32 x 40	24	14	10.2 x 12.7
32 x 64	24	9	10.2 x 20.4

Communications

DH-485 Network Baud Rate Distance Maximum	1200, 2400, 9600, 19.2K 1219 meters (4,000 feet)
DH+ Network Baud Rate Distance Maximum	57.6K, 115.2K, 230.4K 3048 meters (10,000 feet)
RS-232 or DH-485 Point-to-Point Baud Rates Distance Maximum	1200, 2400, 9600, 19.2K 6.1 meters (20 feet)
Remote I/O Baud Rates	57.6K, 2,800 meters (10,000 feet) 115.2K, 1,400 meters (5,000 feet)
DeviceNet Baud Rates	125K, 250K, 500K
ControlNet Network Baud Rate Distance Maximum	5M 1,000 meters (3,280 feet)
DF1/Full Duplex Communications Baud Rate Distance Maximum	1200, 2400, 4800, 9600, 19.2K 15.24 meters (50 feet)
RS-232 Printer Port Baud Rates Parity Data Bits Stop Bits Handshaking	1200, 2400, 9600, 19.2K None, Even, Odd 7 or 8 1 or 2 None, Software (XON, XOFF), Hardware

Agency Certifications

See Nameplate label on each terminal for certifications.

	550	600	900M	900C	1000G	1000C	1400
Emissions (Class B: Light Industrial) EN50081-1:1992				✓ ¹	✓ ¹		✓ ¹
Emissions (Class A: Industrial) EN50081-2:1993	✓	✓	✓			✓	
Immunity (Industrial) EN50082-2:1995	✓	✓	✓	✓	✓	✓	✓
Programmable Controllers Equipment Requirements and Tests) EN61131 2:1995	✓	✓	✓	✓	✓	✓	✓
Low Voltage Directive (Safety Sections of EN61131-2)	✓	✓	✓	✓	✓	✓	✓
UL508	✓	✓	✓	✓	✓	✓	✓
UL1604 Class 1, Div 2, Groups A, B, C, D, T4	✓ ^{2,4}	✓	✓ ³	✓	✓	✓	
UL2279 (IEC79-15) Class 1, Zone 2, Groups IIC, T4		✓			✓	✓	
DEMKO prEN5002 1 Ex Na Group IIC, T4		✓			✓	✓	
CSA 22.2, No. 142	✓	✓	✓	✓	✓	✓	✓
CSA 22.2, No. 213 Class 1, Div 2, Groups A, B, C, D, T4	✓ ^{2,4}	✓	✓ ³	✓	✓	✓	

¹ DeviceNet PanelView terminals are Class A for Emissions

² PV550 (Series C or later) or PV550 Touch Screen Only (Series A or later)

³ PV900M (Series C or later)

⁴ All PV550 terminals have a Temperature Code Rating of T2

Messages, Codes and Self-Test Numbers

This appendix lists:

- terminal messages and codes that may appear during terminal operation
- description of self-test numbers

Types of Terminal Messages

Status Messages

Indicate the terminal is performing an operation that may limit access to the terminal, such as an application download or a communication problem. The message disappears when the terminal completes the operation or when the condition is satisfied.

Reminder Messages

Indicate a minor fault or mistake. Reminder messages appear when an invalid operation is attempted, such as entering an out-of-range value. Pressing any key removes the message.

Warning Messages

Indicate the operation may produce undesirable results. You must respond to warning messages as indicated in the message.

Fault Messages

Indicate the terminal has detected a condition which prevents further operation. The current application will halt. The terminal must be reset (power cycled) to recover from this type of error.

Terminal Messages

Error Number	Terminal Messages	Type	Meaning	Recommended Action
200-206, 300, 318-321, 328, 329, 331, 346, 347, 355, 356, 358, 367, 404, 411, 416, 417, 421-425, 447-449, 457, 459, 700, 1105, 1111, 1113, 1115, 1207-1211, 2002-2009, 2016, 2018, 2021, 2028 and 20229	A fault has occurred. Error = X	Minor Fault or Terminal Fault	A minor fault was detected that could impact terminal operation or a terminal fault was detected.	Press any key to recover from a minor fault. For terminal faults, contact technical support with the error code.
208	Write to logic controller failed	Come Status	Controller does not accept data from the terminal. Controller is not connected.	Check connections (on Remote I/O units). Verify that controller is in run mode and not busy. Verify that controller data files are not in use by other applications.
303	Aborted.	Reminder/File Transfer Status	The terminal received an abort command during a file transfer.	Try again.
304	File read access error	Reminder	Error reading the source file from a source device.	Try again. If problem continues, contact technical support.
305	File write access error	Reminder	Error writing source file.	Try again. If problem continues, contact technical support.
307	File not supported	Reminder/File Transfer Status	File is incompatible with the terminal's firmware.	Contact technical support to verify compatibility. File must be a .PVA file.
308	Timeout	Reminder / File Transfer Status	The terminal was waiting for the partner device in a file transfer, but the terminal timed out before the data or expected reply was received.	Check cable connections or data corruption with noise on cable. Verify that the computer was not reset. Try again.
309-311	Data corrupted. Verify file and retry.	Reminder/File Transfer Status	The data checksum has failed in a file transfer.	Check electrical and cable connections. Try the file transfer again.
312	Unknown device	Reminder / File Transfer Status	Destination or source device is invalid for a read or write application transfer.	Verify the file type entered. Try again.
313	File too large	Reminder/File Transfer Status	File too large to be transferred to the terminal. In a memory card transfer, the card does not have enough space.	Reduce application size. See Appendix A for terminal requirements. If copying to a card, check card space.
314	No Card Inserted	Reminder	You tried to transfer data to/ from a memory card but there is no card in the card slot.	Install a memory card and try again.

Error Number	Terminal Message	Type	Meaning	Recommended Action
315	Unformatted card	Reminder	Memory card is unformatted, contains an unrecognizable format or is corrupt.	Reformat the card or replace it with a new card if corrupt. Try again.
316	Write Protected Card	Reminder / File Transfer Status	A write command to the card failed because the card switch is in the protected mode.	Select write mode by changing the switch on the top edge of the card. Try again.
317	File exists. Cannot overwrite	Reminder/File Transfer Status	See message 342. This message only occurs when the file cannot be renamed.	Change the file name or save to a new memory card.
323	No application on PV terminal	Reminder/File Transfer Status	You tried to load an application on a memory card but there is no application in the terminal.	View the Terminal Info screen to see if an application is loaded in the terminal.
324	Check card status	Reminder/File Transfer Status	Problem formatting the memory card.	Try a new memory card.
325	Unformatted card	Reminder	Memory card is unformatted, contains an unrecognizable format or is corrupt.	Reformat the card or replace it with a new card. Try again.
326	No Card Inserted	Reminder	You tried to transfer data to/ from a memory card but there is no card in the card slot.	Install a memory card and try again.
327	No files	Reminder	You tried to transfer a file from the memory card but there are no files on the card.	Use memory card containing application (.PVA) files.
330	Write Protected Card	Reminder / File Transfer Status	A write command to the card failed because the card switch is in protected mode.	Select write mode by changing the switch on the top edge of the card. Try again.
332	No application on PV terminal	Reminder/File Transfer Status	You tried to load an application on a memory card but there is no application in the terminal.	View the Terminal Info screen to see if an application is loaded in the terminal.
333	File in use - Request denied	Reminder	Attempt to format memory card containing a file used by the application. This usually occurs when an application requires a font file on the memory card.	Format the memory card on a computer or a PanelView terminal that does not have an application loaded.
334	Unexpected card removal. Please disconnect card before removal.	Reminder / File Transfer Status	You removed the memory card during normal operation and did not press the Disconnect button on the Memory Card configuration screen.	Press the Disconnect Card button to close the files on the card. When prompted, remove the card from the slot and then re-insert the card. Enter Configuration Mode and press the Run Mode button.
340	Format erases entire card: 0 or F1 Abort 1 or F2 - Continue	Warning	Operator pressed [F4] Erase / Format Card on the Memory Card configuration screen.	Enter appropriate response: 0 or F1 to abort 1 or F2 to continue
341	Proceed with download? 0 or F1 -Abort 1 or F2 - Continue	Warning	You pressed [F2], Restore From Card on the Memory Card configuration screen.	Enter appropriate response: 0 or F1 to abort 1 or F2 to continue

Error Number	Terminal Message	Type	Meaning	Recommended Action
342	The PVA File exists. 0 or F1 -Abort 1 or F2 - Upload with new PVA file- name	Reminder / File Transfer Status	You pressed [F3], Save To Card on the Memory Card con- figuration screen when the file exists on the card.	Enter appropriate response: 0 or F1 to abort 1 or F2 to upload new PVA file.
361	Value not in range	Reminder	Entered value is outside of valid range.	Enter a value within the valid range.
364	Closing Files . . .	Status	Terminal is preparing for removal of memory card.	Wait for files to close before removing memory card.
365	Remove card . . .	Reminder	You must remove the memory card for the terminal to contin- ues operation.	Remove the memory card.
366	Card disconnection will require card removal to continue operation.	Warning	Attempt to disconnect the memory card.	After memory card is discon- nected it must be removed from card slot before the termi- nal will operate.
392-396	File not supported	Reminder/File Transfer Status	File is incompatible with the terminal's firmware.	Contact technical support to verify compatibility. File must be a .PVA file.
415	Retained memory lost. Presets were loaded.	Reminder	The battery backed memory was invalid during startup. The system defaulted to preset val- ues instead of the last states.	No action necessary. Terminal reverts to defaults.
436	Logic Controller has screen control	Reminder	You tried to change the appli- cation screen but it is config- ured for controller only access.	No action required, controller will change screens as pro- grammed.

DH-485 Messages

Error Number	Terminal Message	Type	Meaning	Recommended Action
612	No active node(s) found on network	Comm Status	No other DH-485 devices can be located on the network.	Verify that the PanelView termi- nal and SLC are correctly con- nected to the system. If the error occurs. again, check the node addresses, baud rates, and maximum node addresses. Reset the terminal.
613	Required network node(s) not found	Comm Status	<ol style="list-style-type: none"> 1. If the message is flashing, the terminal is trying to read or write one or more SLC files that are unavailable. 2. The network is active, but SLCs are not located at the expected nodes. Node and maximum node numbers may not be set correctly. 	<ol style="list-style-type: none"> 1. The files do not exist on SLC. Create files on SLC. 2. Verify that the SLC(s) required by the application are at the expected node addresses with the commu- nication parameters set properly.
615	Duplicate node address	Comm Status	More than one node was assigned the same address.	Verify all device nodes.
616	Data errors on the link	Comm Status	Corrupt data packets were detected on DH-485 network.	Verify controller addressing and baud rate settings. Check for loose or reversed wiring.

ControlLogix Messages				
(See Terminal Codes for messages below)				
Error Number	Terminal Message	Type	Meaning	Recommended Action
634	Write Fail	Comm Status	ControlLogix Tag or address does not exist or is the wrong data type. Designated slot does not contain a ControlLogix Processor.	Check tag address. Check for data type mismatch. Verify ControlLogix slot location.
634	Read Fail	Comm Status	ControlLogix Tag or address does not exist or is the wrong data type. Designated slot does not contain a ControlLogix Processor.	Check tag address. Check for data type mismatch. Verify ControlLogix slot location.
ControlNet Messages				
(See Terminal Codes for messages below)				
634	PanelView offline	Comm Warning	PanelView is offline.	Check connections
634	Write fail.	Comm Warning	PanelView is communicating with the controller. The data table address does not exist.	Check / define data table address in the controller.
634	Write timeout.	Comm Warning	PanelView is not communicating with the logic controller.	Check connections and node configuration in the application.
634	Read fail.	Comm Warning	PanelView is communicating with the controller. The data table address does not exist.	Check/define data table address in the controller.
634	Read timeout.	Comm Warning	PanelView is not communicating with the controller.	Check/define data table address in the controller.
636	Initial write failed.	Reminder	Write to Logic Controller on Startup was configured and on powerup, the PanelView could not write initial values to a node's data table address. or Write to Logic Controller on Startup was not configured and the PanelView was unable to write a controller. Note: The error is only displayed on the first write attempt.	Check/define data table address in the controller. Check communication connections and node configuration in the application.

Remote I/O Messages				
Error Number	Terminal Message	Type	Meaning	Recommended Action
661	Timeout - No Block Transfer Writes	Comm Status	The PLC is communicating with the terminal, but the PanelView is not receiving BTW requests required by the application.	Check ladder logic for missing BTW instructions (instructions are not enabled) or addressing errors. Check for logic controller errors.
662	Timeout - No Block Transfer Reads	Comm Status	The PLC is communicating with the terminal, but the PanelView is not receiving BTR requests required by the application.	Check ladder logic for missing BTR instructions (instructions are not enabled) or addressing errors. Check for logic controller errors.
663	No PLC communications	Comm Status	The PLC is not communicating. Possible causes are disconnected cable, no power to PLC, incorrect baud rate or rack settings for PLC configuration. COMM LED is off.	Check for pulled cables and PLC power. Check baud rate settings and rack configurations. Check wiring of connector. Communication resumes when problem is corrected.
664	PLC in program mode	Comm Status	The PLC is offline (in Program Mode). The COMM LED on the Configuration Mode menu a g.	Place the PLC in run mode to resume communication.
665	Timeout - No Block Transfer Requests	Comm Status	The PLC is communicating with the terminal, but the PanelView is not receiving BTR or BTW requests required by the application.	Check ladder logic for missing BTR or BTW instructions (instructions are not enabled) or addressing errors. Check for logic controller errors.
666	Invalid Rack Configuration	Comm Status	No communications can occur because of an invalid rack configuration.	Correct the RIO rack configuration.
667	Remote I/O Hardware Failed	Comm Status	During startup, the terminal detected a missing, corrupt or nonfunctional Remote I/O card. The terminal will run but not communicate.	Contact technical support and provide specific message.

DH+ Messages

Error Number	Terminal Message	Type	Meaning	Recommended Action
675	Required network node(s) not found	Comm Status	The network is active, but the logic controller(s) are not located at the expected nodes.	Verify that the logic controller(s) required by the application are at the expected node addresses and that the communication parameters are set properly.
676	File access error	Comm Status	<ol style="list-style-type: none"> 1. The terminal is trying to access one or more controller data files that are unavailable. 2. If the message is flashing, the terminal is trying to read or write data files that are unavailable. 	<ol style="list-style-type: none"> 1. The data files do not exist on the controller. Create the data files. 2. The data file is smaller than what is required. For example, the PanelView uses N7:10 but only N7:0 is defined in the controller.

Error Number	Terminal Message	Type	Meaning	Recommended Action
677	Unstable DH+ network	Comm Status	Corrupt data packets or intermittent system configuration was detected on DH+ network.	Verify all controller addressing and baud rate settings. Check for loose or reversed wiring.
678	Duplicate node detected	Comm Status	More than one node was assigned the same address.	Verify all device nodes.
679	No active Node(s) found on network	Comm Status	No other DH+ devices can be located on the network.	Verify that PanelView terminal and logic controller(s) are correctly connected to the system. Check cable and wiring. If error continues, verify that baud rates on the terminal and controller are the same. Communication resumes when the problem is corrected.
681	DH+ hardware failed	Comm Status	During startup, the terminal detected a missing, corrupt, or nonfunctional DH+ card. The terminal will run but not communicate.	Contact technical support and provide the specific terminal message.
1109	Font file unavailable, Font error = ****	Minor Fault or Terminal Fault	You downloaded an application to the PanelView without the appropriate memory card (containing the font file) inserted in the card slot of the terminal.	From the Memory Card screen, press the Disconnect button to close the files on the card. Remove the card from the card slot. Locate the card containing the font file or copy the correct font file to a card. Insert the correct memory card in the card slot and enter Run mode.
1110	No valid application	Reminder	You tried to run an application that has not been downloaded to the terminal.	Download application to terminal.
2005	Application file: Insufficient RAM	Terminal Fault	Application file may be too large.	Try again. If possible, reduce the size of the application.
2007 - 2010	Application file contains errors	Terminal Fault	Application contains incompatible data.	Check application and try again.
2011	Retained memory lost. Presets were loaded.	Reminder	The battery backed memory was invalid during startup. The system defaulted to preset values instead of the last states.	No action necessary. Terminal reverts to defaults.
2012	Application file: Too many retained memory devices	Terminal Fault	The battery-backed RAM is too full to hold all devices requiring presets.	Reduce the number of control objects. Use global objects.
2014	Hardware configuration is corrupted	Terminal Fault	The terminal hardware configuration is corrupt.	Contact technical support.
2030, 2031	Hardware and firmware do not match	Terminal Fault	A mismatch exists between the terminal firmware and the terminal hardware.	Verify that the series and revision markings on the back of the terminal are compatible with the firmware.

Terminal Codes

Terminal Codes are displayed on the PanelView terminal during operation or terminal configuration.

DeviceNet Codes

These codes appear as a banner at the top of an application screen or as an LED status on the terminal's Configuration screen. Error 634 appears in upper left of banner. Codes less than 10 are minor faults and clear automatically when corrected. Codes above 10 require a terminal reset to clear.

DeviceNet Comm Status Code	Indicates:	Recommended Action
1	No connections established. Occurs on power-up until a device connection is established on the network.	Establish a connection over DeviceNet to the PanelView.
2	A connection is in the timed out state. Occurs once I/O messaging is stopped after an I/O connection has been running.	Check the network wiring and that the master device (scanner) is operational.
3	An Explicit-Client tag cannot be obtained. Occurs if the device associated with an Explicit-Client tag is not responding or the peer tag does not exist at the specified class, instance, and attribute number.	Check the data location is correct and that the end device is attached and operational. For write tags, ensure that the appropriate attribute is targeted. If the targeted device is UCMM capable, ensure it has enough explicit message connections to allow the PanelView to take one. If the targeted device is not UCMM capable, ensure that it is owned by a Master device (scanner).
4	A zero length I/O message was received placing the I/O application in idle mode. Occurs when the scanner is in program mode.	Error clears when switched back to run. Correct the problem of the Master sending the I/O idle condition.
5	Message Overrun. Message traffic from the PanelView is being generated quicker than it is possible to send the data. Occurs with large I/O sizes when Change-Of-State is being used and state changes are occurring very quickly or if polling too fast.	Slow down I/O polling or the state changes generating change of state I/O messages. Use cyclic I/O at a fast heartbeat rate rather than change-of-state. Use the production inhibit capability on the master.
11	No network power detected. Occurs if network 24V is not present.	Check the wiring and termination resistors and make sure the baud rate is correct. Reset the terminal.
12	Dup MAC Failure. Occurs if the PanelView powers up with the same Node Address present on the network.	Change the node address to an used address.
13	Bus-off Interrupt occurred. CAN Chip is held in reset. Caused by noise on network signal lines or an attempt to connect to the network at the wrong baud rate.	Check baud rate and network wiring, including termination resistors. Reset the terminal.

These codes appear as a box in the middle of the screen. Error 636 appears in the upper left corner. Operation of the terminal continues. Alert messages can be cleared.

DeviceNet Alert Code	Indicates:	Recommended Action
2	Unsupported DeviceNet Message received. The Network Access Object received a message that is not supported.	Should not occur in normal operation. Clear the message. If problem re-occurs, contact Allen-Bradley.
3	Initial Writes Failure. The Motherboard failed to send all input data to the daughter card prior to network startup.	Should not occur during normal operation. Clear the message. If problem reoccurs, contact Allen-Bradley.
4	Invalid Explicit-Client Address. Occurs at runtime if the node address associated with the Explicit-Client tag is the same as the PanelView.	Clear the message and determine which tag in the application is pointing to the PanelView's node address. Correct the application.
7	Change-Of-State Input Overrun. Occurs if PanelView state changes on I/O input data occurred faster than the PanelView could send them to the I/O scanner.	Clear the message. Excessive network traffic could cause this problem if inputs are changing rapidly.
8	Identity Object Reset Service received over DeviceNet. Occurs if an external device sends an Identify Object Reset Service to the PanelView.	An external network device has requested a PanelView terminal reset. Press a key to clear the alarm.
10	Unsupported DeviceNet message received.	Should not occur during normal operation. Clear the message. If problem reoccurs, contact Allen-Bradley.
12	Invalid ASA Number (0x00000000 or 0xFFFFFFFF). Occurs if the flash memory is corrupt or an invalid ASA number was programmed.	Clear the message. The message occurs each time the terminal is reset. The terminal operates normally but you should correct the problem. Contact Allen-Bradley.
13	Invalid Screen Context Priority received.	Should not occur in normal operation. Clear the message. If problem reoccurs, contact Allen-Bradley.
14	Get Next Scan Item Failed in peer mode.	Should not occur in normal operation. Clear the message. If problem reoccurs, contact Allen-Bradley.
15	Explicit-Client Input Data not received. Will occur if an input (push button) changes a second time before its previous state was sent on the network. Only for Explicit-Client Tags.	Clear the message. Excessive network traffic could cause this problem if inputs are changing rapidly. Handle high speed input data over I/O connections if possible. Also make sure the addressed attribute exists and can be set on the network.
16	I/O Connection Size does not match size of I/O data in Assembly Instances 1 & 2. Programmed connection sizes for I/O do not match the amount of data represented by the I/O type tags.	Clear the message and if the problem reoccurs, consult Allen-Bradley.
19	Get Next Contact Request Failure. In Explicit-Client Mode scanning, the request to obtain the next tag in current context failed.	Should not occur in normal operation. Clear the message. If problem reoccurs, contact Allen-Bradley.

ControlLogix Codes

ControlLogix Terminal Alert Code	Alert Type	Indicates:	Recommended Action(s)
603	Critical fault	File download error	Reset the terminal. If problem occurs again, contact Allen-Bradley for technical support.
9020	Critical fault	An internal fault occurred.	Reset the terminal. If problem occurs again, contact Allen-Bradley for technical support.

ControlNet Codes

These errors appear at the top of the application screen or on the terminal's configuration screen. If you should get an alert number that is not listed, contact Allen-Bradley for technical support.

ControlNet Error Code	Alert Type	Indicates:	Recommended Action(s)
1803	Informational	The communications device has completed the request to force the device into the listen-only state.	The PanelView was detected as having a duplicate node address and is in the listen-only mode. Check the node address (MAC ID) of the devices on the network to verify that addresses are not duplicated.
1824	Warning	The PanelView was forced to a listen-only state.	Contact Allen-Bradley for technical support.
1826	Warning	A fixed tag packet was received but there is no place to route the packet. The data packet is discarded and the error message is displayed.	Contact Allen-Bradley for technical support.
1828	Warning	An attempt was made to open an unsupported transport class.	Contact Allen-Bradley for technical support.
1829	Warning	An attempt was made to open a Class 1 transport with application triggering or a Class 3 transport with cyclic triggering.	Contact Allen-Bradley for technical support.
3333	Warning	A connection has timed out.	A file transfer was unexpectedly interrupted. Try to transfer again.

These messages appear on the terminal screen as DC Error = xx. If you get an alert number that is not listed here, contact Allen-Bradley for technical support.

ControlNet Alert Code	Alert Type	Indicates:	Recommended Action(s)
9000	Critical fault	Interface startup failed.	Contact Allen-Bradley for technical support.
9003	Critical fault	CIP S/N is not valid.	Contact Allen-Bradley for technical support.
9004	Critical fault	Out of buffers.	Contact Allen-Bradley for technical support.
9010	Critical fault	Invalid target node, target node is the same as the PanelView, or larger than the UMAX.	Check node address of all devices on the network including the PanelView terminal.
9012	Communications Warning	ControlNet object received a reset request.	Contact Allen-Bradley for technical support.
9014	Critical fault	A fatal CPU fault occurred.	Contact Allen-Bradley for technical support.
9015	Critical fault	A ControlNet hardware fault occurred.	Contact Allen-Bradley for technical support.
9016	Critical fault	RAM verification failed at startup.	Contact Allen-Bradley for technical support.
9017	Critical fault	CRC verification failed at startup.	Contact Allen-Bradley for technical support.
9018	Critical fault	A critical internal error occurred.	Contact Allen-Bradley for technical support.
9019	Critical fault	An internal fault occurred.	Reset terminal, if problem occurs again, contact Allen-Bradley for technical support.
9020	Critical fault	An internal fault occurred.	Reset terminal. If problem occurs again, reload application. If problem persists, contact Allen-Bradley for technical support.

Remote I/O Communication Loss

When communication fails on a Remote I/O network:

- Object states are maintained and the message "No PLC Communication" is displayed on the screen.
- If Block Transfers are defined for the application, but no BTR or BTW instructions are received, another message appears when the Block Transfer Timeout occurs.

These messages continue to display until communications is established. If a write operation is attempted to the logic program controlling the PanelView objects, the terminal will display the message "Error: Write to Logic Controller failed".

If a PanelView object is activated during a communication loss, the object retains its new state and sends this state value to the controller when communications is established.

Self-test Numbers

The self-test numbers appear on the screen during powerup.

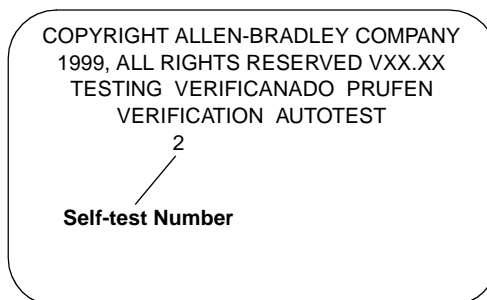

Test Number	Indicates
1	STATIC RAM test
2	Terminal searching for a file to download.
10	Erase boot flash area.
11	Copy boot code
12	Boot code copy successful
13	Boot code copy failed. Check for error after boot code is copied to the onboard flash EPROM.
20	Erase firmware from flash EPROM
21	Copy firmware to firmware flash memory
22	Firmware copy successful
23	Firmware copy failed
24	Performed CRC base firmware check
25	Firmware not compatible with boot code
26	Firmware not compatible with hardware
30	Watchdog test
31	Stuck key test
32	Real time clock test
33	LCD RAM failed
34	Performed CRC extended firmware check

Note: You may not see all of these test numbers during a powerup.

If a test fails, the terminal displays:

ERROR! FEHLER! ERREUR! ERRORE!

The following test numbers appear only if a problem occurs.

Test Number	Indicates
40	No executable code to run after boot
50	Wrong memory card format
60	CPU could not execute code

The table below shows fault conditions that may occur during powerup.

Fault Indicator	Indicates
Solid Red	Static RAM Test failed. Contact technical support.
Blinking Red (6 times per second)	Checksum test on boot code failed. Contact technical support.
Blinking Red (5 seconds on/5 seconds off)	Boot code is incorrect for terminal type (touch screen or keypad). Contact technical support.

European Union Directive Compliance

If the PanelView Operator Terminals are installed within the European Union or EEA regions and have the CE mark, the following regulations apply.

EMC and Low Voltage Directives

These apparatuses are tested to meet Council Directive 89/336/EEC Electromagnetic Compatibility (EMC), and amending directives 91/263/EEC, 92/31/EEC, 93/68/EEC; 72/23/EEC Low Voltage Directive, and amending directive 93/68/EEC using the following standards, in whole or in part:

	550	600	900M	900C	1000G	1000C	1400
Emissions (Class B: Light Industrial) EN50081- 1:1992				✓ ¹	✓ ¹		✓ ¹
Emissions (Class A: Industrial) EN50081-2:1993	✓	✓	✓			✓	
Immunity (Industrial) EN50082-2:1995	✓	✓	✓	✓	✓	✓	✓
Programmable Controllers Equipment Requirements and Tests) EN61131 2:1995	✓	✓	✓	✓	✓	✓	✓
Low Voltage Directive (Safety Sections of EN61131-2)	✓	✓	✓	✓	✓	✓	✓
DEMKO prEN5002 1 Ex Na Group IIC, T4		✓			✓	✓	

¹ DeviceNet PanelView terminals are Class A for Emissions

Intended Use of Product

According to these Standards, the factor which determines, for EMC purposes, whether a product is deemed to be "Industrial" rather than "Residential, commercial or light industrial", is given in clause 1 of EN50081-2 as follows:

Apparatus covered by this standard is not intended for connection to a public mains network supplied from a high- or medium-voltage transformer dedicated for the supply of an installation feeding a manufacturing or similar plant.

When installed in Europe, any other application is in contravention of European Union Directives, and a breach of these laws.

The PanelView 900 color, the 1000 grayscale and the 1400 terminals are certified for direct connection to a low-voltage public mains supply or to a dedicated source, which is intended to interface to a low-voltage public mains supply.

Wiring Recommendations

To reduce electrical noise, connect the PanelView terminal to its own branch circuit. The input power source should be protected by a fuse or circuit breaker rated no more than 15 amps. Route incoming power to the PanelView terminal by a separate path from the communications cable.

Where power and communication lines must cross, they should cross at right angles. Communication lines can be installed in the same conduit as low level DC I/O lines (less than 10 Volts).

Declaration Conformity

Declarations of Conformity are available upon request for the PanelView terminals. Contact your local Allen-Bradley representative or distributor and request the following Allen-Bradley corporate numbers:

- 43500-218-01 for the PanelView 550 keypad or keypad & touch screen terminals
- 43500-219-01 for the DC power versions of the above PanelView 550 terminals
- 43500-307-01 for the PanelView 550 touch screen only terminals
- 43500-260-01 for the PanelView 600 terminals
- 43500-177-01 for the PanelView 900 monochrome terminals
- 43500-235-01 for the PanelView 900 color terminals
- 43500-274-01 for the PanelView 1000 grayscale terminals
- 43500-279-01 for the PanelView 1000 color terminals
- 43500-269-01 for the PanelView 1400 terminals

Glossary

adapter

ControlNet device which responds to scanner messages (also called slave device).

address

1) A character string that uniquely identifies a memory location. 2) A character string that uniquely identifies the physical location of an input or output circuit.

application

In the context of PanelBuilder, an application is a logical arrangement of screens which replace the functions of a control panel and consist of push buttons, data entry objects, control lists and indicators. The application runs in a PanelView terminal.

application file

File containing configuration information for a PanelView terminal. Files exist in either a PanelView (.PVA) or a PanelBuilder (.PBA) format. Files transferred to a terminal are in a .PVA format. Files within PanelBuilder are in a .PBA format.

ATA card

Advanced Technology Attachment (ATA), Intelligent Drive Electronics (IDE), PC Cards (formerly PCMCIA) combine the drive controller and memory storage device. ATA cards can be accessed with standard Copy or Delete commands on a computer. The card looks like a hard drive to the user. You can use the card on a variety of computers without any special setup.

baud

A unit of signaling speed equal to the number of discrete conditions or signal events per second. Where one bit is encoded on each signalling event, the number of baud is the same as the number of bit/s.

boot revision

Revision number of the terminal boot code.

bridge

Device that allows network data to pass from one link to another link.

controller

A unit, such as a programmable controller or relay panel, that controls machine or process elements.

cursor keys

Up, down, left, right arrows on the terminal keypad. These keys are used to move a selection cursor or the active object indicator bar.

DF1

Allen-Bradley communication protocol based on an ANSI X3.28-1976 specification.

cursor keys

Up, down, left, right arrows on the terminal keypad. These keys are used to move a selection cursor or the active object indicator bar.

download

See upload/download.

DH-485 link

Data Highway 485 link. An Allen-Bradley token-passing carrier-band link for a local area network.

DH+™ link

Data Highway Plus link. An Allen-Bradley token-passing baseband link for a local area network.

EMI

Electromagnetic Interference. Any electromagnetic disturbance that interrupts, obstructs, or otherwise impairs the performance of electronic equipment.

EPROM

Erasable Programmable Read-only Memory. A PROM that can be erased, usually with ultraviolet light, then re-programmed with electrical signals. As with all PROMs, it is nonvolatile random-access memory.

EEPROM (flash)

Electrically-Erasable PROM. A type of PROM that can be erased and re-programmed by electrical signals. As with all PROMs, it is nonvolatile random-access memory. Used by the PanelView terminals to stored applications.

firmware

Logic stored in read-only memory.

function keys

Set of keys (labeled F1-F10, F1-F16 or F1-21) on the PanelView terminals used to initiate functions. The function keys are user-defined and may have custom labels.

interscan delay

Determines the amount of time the PanelView waits before re-reading the current screen data from the logic controller.

keeper

The network controller of a ControlNet network.

keypad

Set of 14 keys (numeric 0-9, decimal point, backspace, minus, and enter) to the right of the display on keypad terminals. These keys are used to enter data.

LED

Light-Emitting Diode.

Memory Card

A storage medium which can store a PanelView application and/or a font file.

MicroLogix

An Allen-Bradley programmable controller.

NEMA standards

Consensus standards in the United States for electrical equipment approved by the members of the National Electrical Manufacturers Association (NEMA).

network

Collection of connected nodes including the connection paths, repeaters, and bridges.

Network Access Point (NAP)

Port providing temporary access to a ControlNet network through the RJ-45 connector.

Network Update Time (NUT)

The ControlNet network update time established for the communications link.

node

The connection point at which medium access is provided.

PanelBuilder software

A Windows program used to develop applications which run in PanelView terminals.

PanelView terminal

An Allen-Bradley keypad or touch screen terminal providing the operator interface to the logic controller when an application is executing.

PC

1) Personal Computer. 2) Programmable Controller. 3) Printed Circuit.

PCCC

Acronym for Programmable Controller Communication Commands.

PLC controller

1) An Allen-Bradley programmable controller with a name that has the prefix PLC. See programmable controller.

preset value

A value loaded into a controller data table when an application is first started.

programmable controller

A solid-state control system that has a user-programmable memory for storage of instructions to implement specific functions such as I/O control, logic, timing, counting, report generation, communication, arithmetic, and data file manipulation. A controller consists of a central processor, input/output interface, and memory. A controller is designed as an industrial control system.

real time clock

Internal clock that provides time, day, month and year.

remote I/O

1) I/O connected to a processor across a serial link. With a serial link, remote I/O can be located long distances from the processor.

remote I/O link

A serial link for carrying I/O data between a PLC or SLC processor/scanner and remote I/O adapters.

repeater

Two-port component that receives and transmits all data from one segment to another.

restore

To load an application from a memory (PC) card.

RS-232

An EIA standard that specifies electrical, mechanical, and functional characteristics for serial binary communication circuits in a point-to-point link.

RS-485

An EIA standard that specifies electrical characteristics of balanced-voltage digital interface circuits in a multi-point link.

scheduled messages

Messages that occur at a regular specified interval. They are assigned a particular portion of the network update time (NUT) and are always transmitted at that time.

safety extra-low voltage (SELV)

A voltage which, under all operating conditions does not exceed 42.4 V peak or dc between conductors, or between any conductor and earth, in a circuit which is isolated from the main power supply by means of a safety isolating transformer or an equivalent means. National regulations have to be considered for a correct isolation voltage rating.

scratchpad

A window that appears in the center of the terminal display that allows data entry using the terminal or screen keypad.

screen

1) the viewing surface on which data is displayed. 2) The visual image on a screen.

segment

Trunk-cable sections connected through taps with terminators at each end and no repeaters.

SLC

An Allen-Bradley programmable controller with a name that has the prefix SLC.

SMAX

Highest ControlNet node address which can communicate during the scheduled portion of the network update interval.

tap

Hardware component that connects devices to the ControlNet trunk cable.

touch cell

1 of 128 or 384 rectangular areas on the terminal display that can sense when touched.

touch screen

The display window of the terminal that responds when touched.

trunk cable

Bus or central part of a cable system.

unscheduled messages

Messages that are sent on an as needed basis. Unscheduled messages are sent during the unscheduled portion of the network update interval.

UMAX

Highest ControlNet node address which can communicate during the unscheduled portion of the network update interval.

upload/download

Commonly referred to the reading/writing across a link relatively large blocks of data from one device to another. Whether it is considered an upload or download may depend upon whether it is a read or write and upon which device initiates the transaction. When data is transferred to a programming device, it is considered an upload. When data is transferred from a programming device, it is considered a download.

A

- AC power
 - connecting, 2-2–2-4
 - electrical ratings, 2-2
- accessories
 - antiglare overlay, 1-29
 - backlight lamp, 1-30
 - cables, 1-29–1-30
 - file transfer utility, 1-29
 - function key legend kits, 1-28
 - memory card retainer, 1-28
 - memory cards, 1-28
 - mounting clips, 1-30
 - mounting studs, 1-30
 - real time clock, 1-30
 - wallmount power supply, 1-29
- alarms
 - content, 5-12
 - description, 1-27
- Allen-Bradley, contacting for assistance, P-44
- antiglare overlay, 1-29
- application files
 - running, 1-24
 - settings, 3-1
- audience, P-43

B

- backlight lamps, 1-30
 - replacing, 11-5
- bar graphs, 5-10
- boot code revision, 3-17

C

- cables
 - ControlNet, 10-23
 - DeviceNet, 10-25
 - DF1, 10-29
 - DH+, 10-15
 - DH-485, 1-29, 10-7
 - DH-485 network, 10-8, 10-9
 - Remote I/O, 1-30, 10-4
 - RS-232, 1-30
- card, memory, 1-28, 3-5, 4-1
- certifications, A-11
- cleaning, display window, 11-5

- Comm LED, 3-3, 11-4
- communication ports, available, 1-2–1-5
- configuration mode menu, 1-26
 - accessing, 3-2
 - operations list, 3-2
- configuration screens
 - ControlNet, 3-10
 - DeviceNet, 3-12
 - DF1, 3-14
 - DH+, 3-8
 - DH-485, 3-6
 - language selection, 3-4
 - memory card transfers, 3-5
 - preset operations, 3-16
 - printer setup, 3-26
 - Remote I/O, 2-9, 3-9
 - screen setup, 3-18–3-23
 - terminal information, 3-17
 - time and date, 3-25
- contacting Allen-Bradley, P-44
- control lists, 5-3
 - activating, 5-3
 - active item, 5-3
 - active list, 5-3
 - cursor, 5-4
 - list keys, 5-4
 - piloted, 5-4
 - selecting an item, 5-5
 - vertical indicator bar, 5-4
- ControlNet communications
 - active node, 3-10
 - available terminals, 1-2–1-5
 - channel status, 3-11
 - communication status, 3-10
 - compatible controllers, 10-21
 - connecting a printer, 10-30
 - ControlNet ports, 10-21
 - ControlNet protocol, 10-20
 - firmware revision, 3-10
 - interscan delay, 3-10
 - making connections, 10-23
 - new node, 3-10
 - related information, 10-20
 - serial number, 3-10
 - typical network, 10-22

D

data entry

- keypad enable button, 5-6
- numeric entry cursor point, 5-6
- scratchpad, 5-6

date and time setup, 3-25

DC power

- connecting, 2-5–2-6
- electrical ratings, 2-5

declarations of conformity, C-2

degaussing PanelView 1400

- enabling/disabling, 3-23
- setting schedule, 3-23

DeviceNet communications

- active baud rate, 3-12
- active node, 3-12
- available terminals, 1-2–1-5
- bus-off interrupt, 3-13
- connecting a computer, 10-30
- connecting a printer, 10-30
- DeviceNet ports, 10-25
- input size, 3-13
- interscan delay, 3-13
- LED indicators, 3-13
- making connections, 10-25
- new baud rate, 3-12
- new node, 3-12
- output size, 3-13

DF1 communications

- available terminals, 1-2–1-5
- baud rate, 3-14
- Comm LED, 3-15
- compatible controllers, 10-27
- configuration screen, 3-14
- connecting to a DeviceNet network, 10-29
- connecting to a MicroLogix 1000, 10-28
- connecting to an SLC or PLC, 10-28
- DF1 port pinouts, 10-28
- DF1 ports, 10-27
- error detection (CRC or BCC), 3-14
- handshaking, 3-15
- null modem cable, 10-29
- serial communication parameters, 3-14
- using a modem, 10-29

DH+ communications

- available terminals, 1-2–1-5
- baud, 3-8
- cable, 10-15
- configuration screen, 3-8, 3-13

- connecting a computer, 10-30
- connecting a printer, 10-30
- DH+ communications port, 10-13
- LED indicators, 3-8
- making DH+ connections, 10-15
- node, 3-8
- RS-232 port, 10-13
- typical system configuration, 10-14

DH-485 communications

- available terminals, 1-1–1-5
- baud rate, 3-6
- cables, 10-7
- configuration screen, 3-6
- connecting a computer, 10-10
- connecting a printer, 10-30
- DH-485 communications port, 10-6
- DH-485 programming connector, 10-6
- hand-held terminal connection, 10-12
- LED indicators, 3-7
- link coupler, 10-8, 10-9
- maximum node, 3-6
- MicroLogix connection, 10-9
- network connection, 10-8
- node address, 3-6
- ports, 10-6
- power supply, 10-10
- RS-232 port, 10-6
- SLC connection, 10-7
- SLC connection using AIC+, 10-9

display

- adjusting settings, 3-18–3-23
- cleaning window, 11-5

displays

- color, 1-1
- grayscale, 1-1
- monochrome, 1-1

E

European Union Directive Compliance, P-43, C-1

F

Fault LED, 3-3, 11-4

fault messages, B-1

file transfer utility, 1-29

firmware revision, 3-17

font files, 3-17, 4-8

function key legend kits, 1-25, 1-28

I

- indicators
 - bar graphs, 5-10
 - list indicators, 5-10
 - multistate indicators, 5-10
- initial screen, 2-8
- installation of terminals, P-43, P-44
- Installing the PanelView 1000
 - clearances, 8-4
 - cutout dimensions, 8-5
 - enclosures, 8-1
 - hazardous locations, 8-1
 - mounting dimensions, 8-3
 - panel installation, 8-6
 - required tools, 8-2
- Installing the PanelView 1400
 - clip mounting, 9-5
 - cutout dimensions, 9-4
 - enclosures, 9-1
 - mounting dimensions, 9-2
 - required tools, 9-1
 - stud mounting, 9-7
- Installing the PanelView 550
 - clearances, 6-3
 - cutout dimensions, 6-4
 - enclosures, 6-1
 - hazardous locations, 6-1
 - mounting dimensions, 6-2
 - panel installation, 6-5
 - required tools, 6-2
- Installing the PanelView 600
 - clearances, 7-3
 - cutout dimensions, 7-2
 - enclosures, 7-1
 - hazardous locations, 7-1
 - mounting dimensions, 7-2
 - panel installation, 7-4
 - required tools, 7-2
- Installing the PanelView 900
 - clearances, 8-4
 - cutout dimensions, 8-5
 - enclosures, 8-1
 - hazardous locations, 8-1
 - mounting dimensions, 8-2
 - panel installation, 8-6
 - required tools, 8-2

K

- key repeat
 - delay, 3-16
 - rate, 3-16
- keypad enable button, 5-6
- keypad terminals
 - available options, 1-1–1-5
 - operation, 1-25

L

- language
 - selection, 3-4
 - types, 3-4
- LEDs
 - Comm, 3-3, 11-4
 - Fault, 3-3, 11-4
- link coupler, 1-29, 10-8, 10-9
- list indicators, 5-10
- list keys
 - control lists, 5-4
 - screen selector lists, 5-9

M

- manual contents, P-42
- memory card, 1-28
 - closing files on card, 3-5
 - disconnect button, 3-5
 - erase and format, 3-5
 - installation, 4-2
 - loading application from card, 4-4
 - loading application onto card, 4-6
 - removing, 3-5, 4-8
 - restoring application from card, 3-5
 - saving application to card, 3-5
 - storing font files, 4-8
 - types, 4-1
 - using retainer, 4-2
 - viewing applications on card, 3-5
 - write protection, 11-3, B-3
- message displays, 5-11
- messages
 - fault, B-1
 - general, B-2
 - reminder, B-1
 - Remote I/O, B-12
 - status, B-1
 - warning, B-1

mounting clips, 1-30
mounting studs, 1-30
multistate indicators, 5-10

N

numeric data displays, 5-11
numeric entry controls
 cursor point, 5-6
 description, 5-6
 entering data, 5-7
 keypad enable button, 5-6
 scratchpad, 5-6

P

PanelView 1000
 adjusting display intensity, 3-19
 connecting AC power, 2-2
 connecting DC power, 2-5
 features, 1-16
 installation, 8-1
 resetting, 2-7
 screen adjustments, 3-19, 3-22
 screen saver, 3-19, 3-22
 specifications, A-7
PanelView 1400
 adjusting display intensity, 3-24
 aligning the touch grid, 3-24
 connecting AC power, 2-2
 degaussing, 3-23
 features, 1-20
 installation, 9-1
 resetting, 2-7
 screen adjustments, 3-23
 screen saver, 3-23
 specifications, A-9
PanelView 550
 adjusting contrast, 3-18
 connecting AC power, 2-2
 connecting DC power, 2-5
 installation, 6-1
 resetting, 2-7
 screen adjustments, 3-18
 specifications, A-1
 turning backlight on and off, 3-18
PanelView 600
 adjusting display intensity, 3-19
 connecting AC power, 2-2
 connecting DC power, 2-5

 features, 1-12
 installation, 7-1
 resetting, 2-7
 screen adjustments, 3-19
 screen saver, 3-19
 specifications, A-2

PanelView 900
 adjusting display intensity, 3-19, 3-20
 conditioning the display, 3-21
 connecting AC power, 2-2, 2-5
 features, 1-16
 installation, 8-1
 resetting, 2-7
 screen adjustments, 3-19, 3-20
 screen saver, 3-19, 3-20
 specifications, A-4

PanelView terminals
 operation, 1-25
 types, 1-1

Pass-Through, 2-10, 3-9

personal computer interface converter, 1-29
 connecting earth ground, 10-10

PIC converter, 10-10

power connection
 AC power, 2-2–2-4
 DC power, 2-5–2-6

power supply, 1-29, 10-10

powerup sequence, 2-8
 DH-485 terminals, 2-8
 Remote I/O terminals, 2-9
 RS-232 terminals, 2-8

preset operations
 initial values, 3-16
 last state values, 3-16
 powerup screen, 3-16
 preset values, 3-16
 restart and load values, 3-16

printer port setup
 communication settings, 3-26
 configuring, 3-26
 enabling/disabling printing, 3-27
 handshaking, 3-26
 port pinout, 10-30
 top of form, 3-27

printing, 1-26, 5-12

push buttons
 hold time, 5-2
 operation, 5-2

R

real time clock, 1-30
 replacement, 11-5
 reminder messages, B-1
 Remote, 3-9
 Remote I/O communications
 available terminals, 1-2-1-5
 baud rate, 2-10, 3-9
 block transfer timeout, 2-10
 cable, 10-4
 configuration screen, 3-9
 connecting a computer, 10-30
 connecting a printer, 10-30
 connecting to a Remote I/O scanner, 10-4
 last chassis, 2-10, 3-9
 out-of-box application, 2-9
 Pass-Through, 2-10, 3-9
 rack number, 2-10, 3-9
 rack size, 2-10, 3-9
 Remote I/O port, 10-2
 RS-232 port, 10-2
 starting module group, 2-10
 supported controllers, 10-3
 reset video, 3-2
 resetting
 PanelView 1000, 2-7
 PanelView 1400, 2-7
 PanelView 550, 2-7
 PanelView 600, 2-7
 PanelView 900, 2-7
 RS-232 (DH-485) communications
 available terminals, 1-2-1-5
 connecting a computer, 10-18
 connecting a printer, 10-30
 connecting to DH+ link, 10-19
 RS-232 port, 10-16
 SLC connection, 10-17
 RS-232 serial port
 cables, 10-30
 configuring, 3-26
 connecting a computer, 10-30
 connecting a printer, 10-30
 port pinout, 10-30
 run mode, 3-2

S

scale, bar graph, 5-10
 scratchpad
 cancelling, 5-7
 entering data, 5-7
 screen saver, 3-19-3-23
 screen selectors
 activating a list, 5-8
 description, 5-8
 list keys, 5-9
 selecting an item, 5-8
 vertical indicator bar, 5-9
 self-test numbers, 2-8, B-13
 specifications
 PanelView 1000, A-7
 PanelView 1400, A-9
 PanelView 550, A-1
 PanelView 600, A-2
 PanelView 900, A-4
 status messages, B-1

T

terminal information
 boot revision, 3-17
 current application, 3-17
 firmware revision, 3-17
 font file in use, 3-17
 hardware configuration, 3-17
 terminal messages, B-2
 terminals
 installation, P-43, P-44
 types, 1-1
 terminology, P-43
 time and date setup, 3-25
 touch screen terminals
 available options, 1-2-1-5
 troubleshooting
 contacting Allen-Bradley, P-44
 correcting problems, 11-2
 problems, 11-2
 terminal messages, B-2

W

wallmount power supply, 1-29, 10-10
 warning messages, B-1
 write protection
 memory card, 11-3, B-3



Rockwell Automation helps its customers receive a superior return on their investment by bringing together leading brands in industrial automation, creating a broad spectrum of easy-to-integrate products. These are supported by local technical resources available worldwide, a global network of system solutions providers, and the advanced technology resources of Rockwell.

Worldwide representation.



Argentina • Australia • Austria • Bahrain • Belgium • Bolivia • Brazil • Bulgaria • Canada • Chile • China, People's Republic of • Colombia • Costa Rica • Croatia • Cyprus • Czech Republic • Denmark • Dominican Republic • Ecuador • Egypt • El Salvador • Finland • France • Germany • Ghana • Greece • Guatemala • Honduras • Hong Kong • Hungary • Iceland • India • Indonesia • Iran • Ireland • Israel • Italy • Jamaica • Japan • Jordan • Korea • Kuwait • Lebanon • Macau • Malaysia • Malta • Mexico • Morocco • The Netherlands • New Zealand • Nigeria • Norway • Oman • Pakistan • Panama • Peru • Philippines • Poland • Portugal • Puerto Rico • Qatar • Romania • Russia • Saudi Arabia • Singapore • Slovakia • Slovenia • South Africa, Republic of • Spain • Sweden • Switzerland • Taiwan • Thailand • Trinidad • Tunisia • Turkey • United Arab Emirates • United Kingdom • United States • Uruguay • Venezuela

Rockwell Automation Headquarters, 1201 South Second Street, Milwaukee, WI 53204 USA, Tel: (1) 414 382-2000, Fax: (1) 414 382-4444

Rockwell Automation European Headquarters SA/NV, avenue Hermann Debrouxlaan, 46, 1160 Brussels, Belgium, Tel: (32) 2 663 06 00, Fax: (32) 2 663 06 40

Rockwell Automation Asia Pacific Headquarters, 27/F Citicorp Centre, 18 Whitfield Road, Causeway Bay, Hong Kong, Tel: (852) 2887 4788, Fax: (852) 2508 1846