



# Metro 70 - Metro 70 Tunnel

G31 propane



Instructions for installation (GB / IE)



Please retain this document carefully



## Contents

	page
Foreword	2
1. Introduction	3
2. EC Declaration of Conformity	3
3. SAFETY	3
3.1 General	3
3.2 Regulations	3
3.3 Precautionary measures / safety instructions regarding installation	3
4. Instructions	4
5. Unpacking	4
6. Installation	4
6.1 Regulations	4
6.2 Gas type	4
6.3 Gas connection	4
6.4 Positioning the appliance	5
6.5 Flue / combustion air supply system	6
6.6 Building the chimney breast	9
6.7 Installing the control box	10
6.8 Adjusting the appliance	10
6.9 Arranging the logs / pebbles	12
6.10 Glass window	15
7. Wireless remote control	16
7.1 Receiver	16
8. Final inspection	17
8.1 Gastightness	17
8.2 Gas pressure/pre-pressure	17
8.3 Igniting the pilot and main burner	18
8.4 Flame effect	18
9. Maintenance	19
10. Completion	19
11. Troubleshooting	20
Annex 1 Components supplied	23
Annex 2 Technical data	23
Annex 3 Spare parts	23

## Foreword

As manufacturer of gas heating appliances, DRU develops and produces products to meet the highest possible quality, performance and safety requirements.

As a result of which the user is able to enjoy using your appliance for years to come.

This appliance is CE marked; it complies with the essential requirements of the European Appliance Directive.

The appliance is supplied with two manuals: the installation manual and the user manual.

You the installer should be professionally skilled in the field of decorative gas heating.

The installation manual gives you all the information you will need to be able to install the appliance in such a way that it works correctly and safely.

This manual deals with the installation of the appliance and the appropriate regulations. It also includes the technical data for the appliance and information on maintenance and troubleshooting.

***Please read and use this installation manual carefully.***

In the manuals the following symbols are used to denote important information:



**What to do**

**!Tip**

**Suggestions and recommendations**

**!N.B.**

**These instructions are important to avoid possible problems during installation and/or use.**



**N.B.**

**These instructions are important to avoid fire, personal injury or other serious damage.**

***Once you have completed the installation you are to hand both the user manual and this installation manual to the user.***

## 1. Introduction

The appliance is supplied in two versions, the Metro 70 and the Metro 70 tunnel.

This version of the Metro 70 and the Metro 70 tunnel is suitable for propane gas. The safe operation of the appliance is guaranteed by the use of a second thermocouple fitted to the main burner.

The Metro 70 is a “standard” appliance. It is always mounted against a wall. The Metro 70 tunnel is a “look-through appliance”; it has a pane at the front and back.

The Metro 70 and Metro 70 tunnel are room-sealed atmospheric gas-fired heating appliances. A room-sealed appliance does not extract the combustion air from the living environment, but from outside. This is done by means of a combined flue gas discharge system / combustion air supply system. In this concentric system, the outer pipe functions as the air supply and the inner pipe functions as the flue gas discharge.

This system can be installed through the wall or through the roof.

These appliances are built within a chimney breast. In order to reach a proper heat discharge, the chimney breast must be ventilated. DRU is able to supply various ventilation elements.

The appliances are supplied with a wireless remote control that works on batteries.

## 2. EC Declaration of Conformity

We hereby declare that the design and construction of the decorative gas heating appliance marketed by DRU conforms with the essential requirements of the Gas Appliance Directive.

This declaration will be rendered invalid should the appliance be altered in any way without the written consent of DRU.

Product: *Decorative gas heating appliance*

Type: *Metro 70*

*Metro 70 Tunnel*

Applicable EC Directives: *90/396/EEC*

Applicable harmonised standards: *NEN-EN-613*

*NEN-EN-613/A1*

In-house measures guarantee that serially produced appliances always conform with the essential requirements of the current EC Directives and the applicable standards.

R. Gelten

DRU VERWARMING B.V.

Postbus 1021, 6920 BA Duiven

Ratio 8, 6921 RW Duiven

www.dru.nl

## 3. SAFETY



**N.B.**

### 3.1 General

- Please read this chapter on safety carefully before commencing installation or maintenance
- Always observe universal regulations and the precautionary measures / safety instructions in this manual.

### 3.2 Regulations

The appliance should be installed in compliance with current national, local and constructional (installation) regulations.

### 3.3 Precautionary measures / safety instructions regarding installation

Observe the following precautions / safety regulations precisely:

- You may only install and/or service this appliance if you are a qualified installer skilled in installing decorative gas fires;
- do not adjust the appliance in any way;
- use incombustible and heat-resistant materials for building a chimney breast, including the back wall, the inside and the top of the chimney breast;
- the minimum internal dimensions required for the chimney breast must be taken into account;
- the chimney breast should be ventilated by vents with total free vent area of 200 cm<sup>2</sup>;
- only use the flue / combustion air supply systems supplied by DRU;
- use the wall brackets supplied to mount the appliance;
- do not install the appliance flat against the back wall;
- leave the space between the feet free;
- do not cover and/or pack the appliance with an insulating blanket or any other material;
- Make sure combustible objects and / or materials have a minimum distance from the appliance of 500 mm;
- only use the log/pebble set supplied;

- ⇒ arrange the logs/pebbles exactly as described;
- ⇒ make sure the pilot burner and the space around it is kept free;
- ⇒ make sure thermocouple 2 and the space around it are kept free;
- ⇒ avoid any dirt in the gas pipes and connections;
- ⇒ test the gastightness of all connections before use;
- ⇒ use heat-resistant electrical connection materials;
- ⇒ install the electrical connections away from the appliance;
- ⇒ avoid blocking the explosion hatch/hatches;
- ⇒ ensure the explosion hatch/hatches on top of the heater are right on their seats, before you close the chimney breast;
- ⇒ do not ignite the appliance until installation has been completed.

#### 4. Instructions

To ensure the appliance works correctly and safely, always take the following points into consideration during installation:

- ⇒ place the control box supplied as low as possible;
- ⇒ ensure the ignition wire does not lie across the receiver;
- ⇒ ensure the ignition wire does not touch or cross the aerial;
- ⇒ to avoid weakening the spark ensure the ignition wire does not touch anything metal;
- ⇒ if the appliance is to be built in flush with the wall, finish the edges neatly;
- ⇒ do not plaster over the flanges;
- ⇒ avoid damaging the glass when removing/fitting the window pane;
- ⇒ to prevent dirt burning into the glass, make sure it is clean before use;
- ⇒ make sure that the wires of thermocouple 2 cannot come into contact with hot parts.

#### 5. Unpacking

Please take the following points into consideration when unpacking the appliance:

- ⇒ Check the appliance for transit damage;
- ⇒ Contact DRU Service if necessary;

Once the packaging material has been removed, you should have the following components:

- **Socket spanner:** You will find this in the space between the assembly frame and the combustion chamber.
- **Trimnings:** These are in the same space.

Once you have removed the glass pane you can remove the box of components from the combustion chamber.

**!N.B.** Be careful not to damage the glass when removing/fitting the window pane.

- ⇒ Remove the window as described in paragraph 6.10.1.

- ⇒ Take the box of components out of the combustion chamber.

Annex 1 / Table 4 specifies the components you should have once everything has been unpacked.

- ⇒ Contact DRU Service if after unpacking the appliance you do not have all the components.
- ⇒ Dispose of the packaging in an appropriate manner.

#### 6. Installation

Please read the manual carefully to ensure that once installed the appliance will work correctly and safely.

**!N.B.** Install the appliance in the order described in this chapter.

##### 6.1 Regulations

- Observe the current applicable (installation) regulations.
- Observe the regulations/instructions laid down in this manual.

##### 6.2 Gas type

The type plate specifies the type of gas, gas pressure, and the country this appliance is intended for. The type plate is on a chain and that is where it should stay.



**!N.B.** Check that the appliance is suitable for the local gas type and pressure.

##### 6.3 Gas connection

The gas connection should have a gas tap located near the appliance.



**!N.B.** Prevent any dirt getting into the gas pipes or connections.

The following requirements apply for the gas connection:

- ⇒ the size of the gas pipe should be such that no pressure loss can occur;
- ⇒ the gas tap must be CE marked;

- ➡ the gas tap should be accessible at all times.
- ➡ Do not twist the gas tap when connecting the gas pipe.

### 6.4 Positioning the appliance

Position the fire as follows:

- !N.B.**
- Make sure combustible objects and / or materials have a minimum distance from the appliance of 500 mm;
  - Do not adjust the appliance in any way.
- ➡ Determine the position of the appliance.
  - ➡ Create a gas connection in the appropriate position; see section 0 for details.
  - ➡ Create a duct for the flue / combustion air supply system, with the diameter shown below; see section 6.5 for details.
  - ➡ Ø160 mm for a wall duct of incombustible material;
  - ➡ Ø 250 mm for a wall duct of combustible material
  - ➡ Ø160 mm for a roof duct of incombustible material;
  - ➡ Ø 250 mm for a roof duct of combustible material

- !N.B.**
- Allow for the depth of the appliance (see Fig. 2)  
(Metro 70: minimum of 400 mm; Metro 70 Tunnel: minimum of 446 mm).
  - Allow for the build-in height; this will depend on the height of the adjustable feet (see Fig. 1)

- ➡ Move the appliance into its intended position.
- The gas control is mounted under the appliance, at the burner plate. It should be disconnected and placed in the control box at a later stage. For placing the gas control in the control box, see section 6.7.

Follow the procedure described below:

- ➡ Disconnect the pipes from the gas control (flexible gas pipe, aluminium pilot-flame pipe and thermocouple 1).
- !N.B** The red wire of thermocouple 2 must remain connected to the gas control.
- ➡ Disconnect the gas control from the burner plate by unscrewing the self-tapping screw.
  - ➡ Carefully unwind the red and black wires of thermocouple 2.
  - ➡ Lay the gas control together with the wires of thermocouple 2 in the direction of the control box.

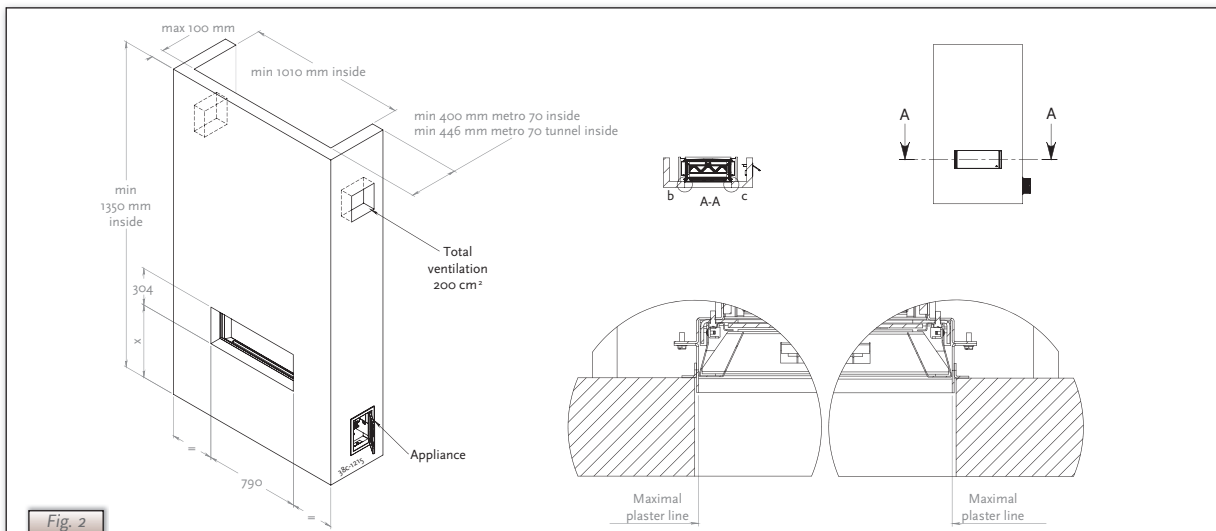
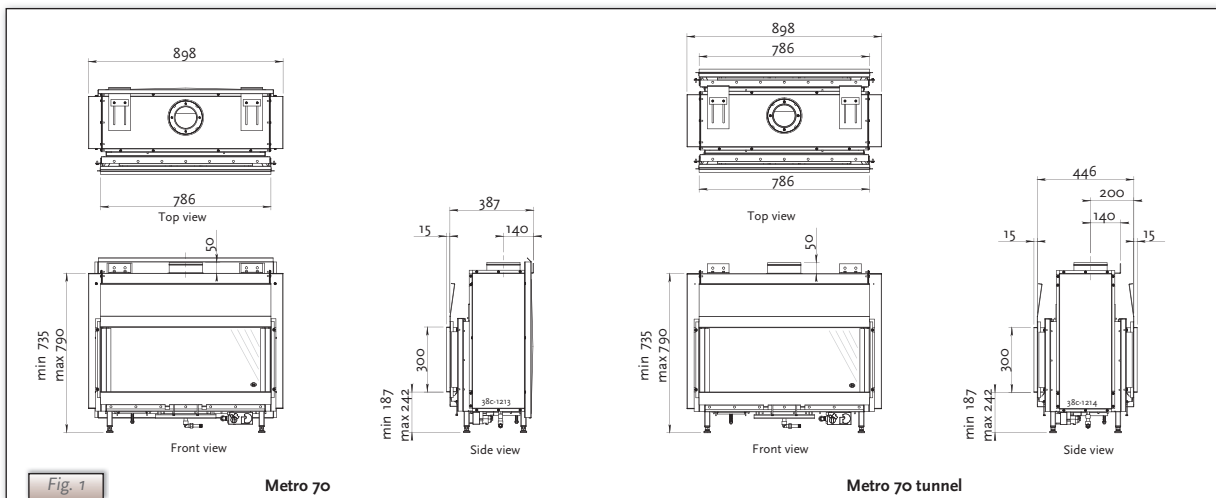



- N.B.** - Avoid dirt in the hoses.  
- Avoid kinks in the hoses.

⇒ Unroll the hoses towards the control box.

⇒ Unroll the ignition wire towards the control box.

**!N.B.** The type plate should be connected to the chain.

⇒ Lay the chain with the type plate facing the control box.

⇒ Adjust the height of the appliance

⇒ Using a spirit level to ensure it is absolutely level.



- N.B.** - Do not install the appliance flat against the back wall.  
- Leave the space between the feet free.

- Do not cover and/or pack the appliance with an insulating blanket or any other material.

⇒ Secure the appliance against the wall using the wall brackets and rawplugs supplied (see Fig. 3.)

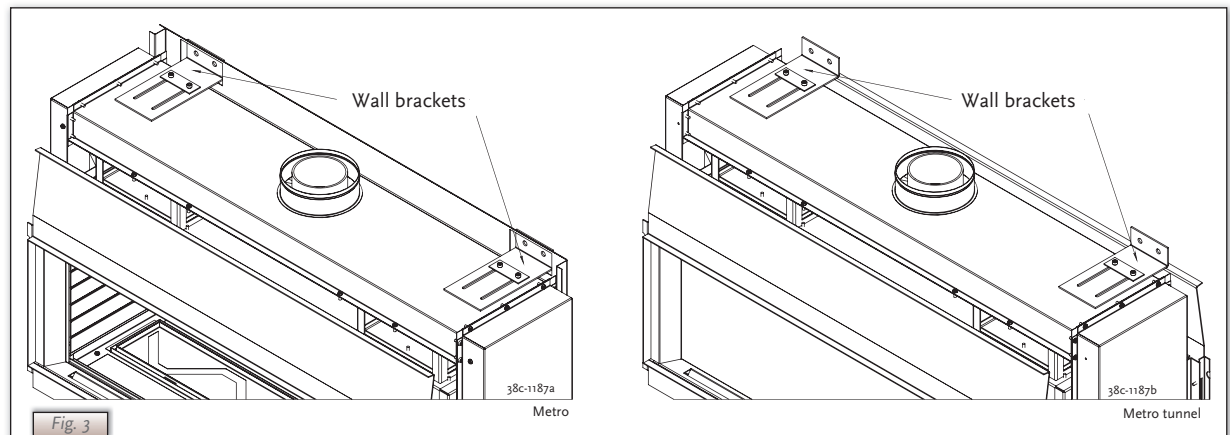

## 6.5 Flue / combustion air supply system

### 6.5.1 General

The appliance is type C11/C31.

The appliance is connected to a combined flue/combustion air supply system, from here on referred to as the concentric system.

It is also possible to use an existing duct.



**N.B.:** Only use the concentric system (Ø 100/150mm) and related accessories supplied by DRU. The system has been approved along with the equipment. Where non-DRU systems are used, DRU cannot guarantee or accept any responsibility for the proper and safe working of the same.

The concentric system is constructed from the appliance up.

If, for structural reasons, the concentric system is fitted first, the appliance can be connected later using a piece of telescopic pipe.

An equipment can be fitted with a wall duct (please refer to 6.5.2) or a roof duct (please refer to 6.5.3).

### 6.5.2 Installation with a wall duct

#### 6.5.2.1 Constructing the concentric system

The settings of the equipment are made in the factory with a 1 to 4 meter vertical pipe + 90° pipe bend + wall duct. In such case, the system does not require any further adjustments. If your situation is not as described above, you should remove the air inlet guide as mentioned in 6.8.2.

Always start with a vertical pipe on the equipment. You may begin with a vertical pipe of at least 0.5 meter and a maximum of 4 meters.

**N.B.:** Please note that if you install a 0.5 meters vertical pipe on the equipment, the length should not exceed 2 meters.

The air inlet guide should be removed (see 6.8.2).  
(See the example in Fig. 4a).

**N.B.:** Please note that if you install a 1 to max. 4 meters vertical pipe on the equipment, the maximum horizontal length should not exceed 3 meters. The air inlet guide should be removed (see 6.8.2) (see the example in Fig. 4b)

**6.5.2.2 Installing the concentric system**

To install the concentric system commence as follows:

Construct the system from the (connection stub of the) appliance up

**N.B.:**

- Maintain a distance of at least 50 mm between the outside of the concentric system and the walls and /or ceiling. If the system will be built in (for instance) a cove, it should be fully made of incombustible material;
- Use heat-resistant insulating material for ducts made of combustible material.

Connect the concentric pipe sections and the bend(s);  
Fit a clamping strip and silicone sealing ring to every connection;

Secure the clamping strip with a self-tapping screw in places which will be inaccessible after installation;

Use enough brackets to ensure that the weight of the pipes does not rest on the appliance;

Determine the remaining length of the wall duct;

Cut the wall duct to size;

Fit the wall duct with the bead//double edge at the top.

Be sure to maintain the correct insertion length.

**N.B.:** Mount the wall duct onto a heat-resistant plate for use with a wall duct made of combustible material.

Fix the wall duct with four screws in the appropriate holes.

**N.B.:** Fit the horizontal concentric pipe sections sloping towards the wall duct to stop rain getting in.

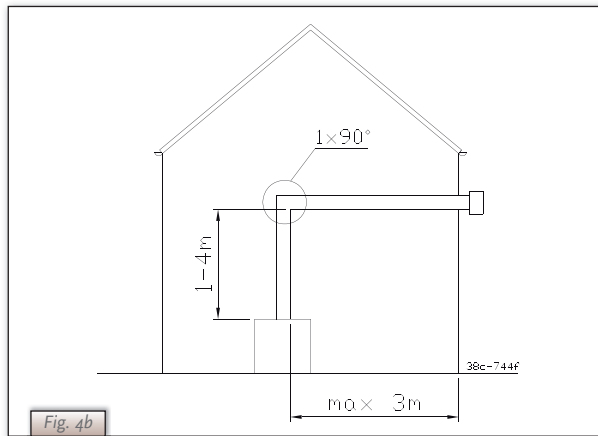
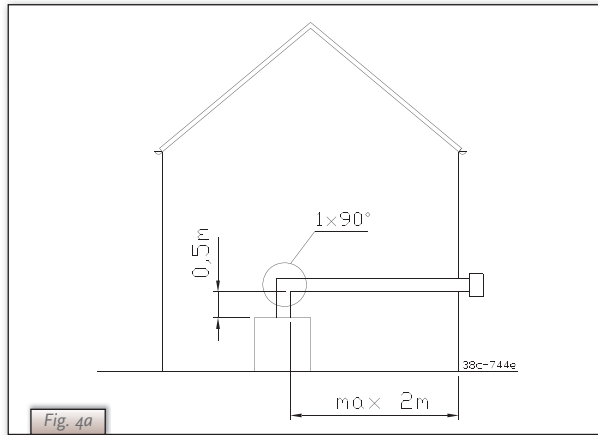

**6.5.3 Use with a roof duct**

**6.5.3.1 Constructing the concentric system**

A concentric pipe of at least one meter should first be connected vertically to the equipment. The baffle and/or air inlet guides will be adjusted according to the structure of the concentric system.

You may proceed as follows:

1. Determine the number of pipe bends required (no distinction is made between 45° and 90° pipe bends).
2. Determine the horizontal pipe lengths in meters.
3. Determine the vertical/ sloping pipe lengths (without roof ducts) in meters.

With this data, you can check using the Table 1, whether the drain system is permissible and the adjustments specific to the same. The table functions as follows: in the first 2 left columns, search for the number of the pipe bends and the horizontal length and in the 3 column, search for the vertical/ sloping length, after which you will arrive at the letter A, B or C. Thereafter, click in Table 2 to find out the instructions relating to the air inlet guide and baffle (for installation / removal, see 6.8).

The following are 2 examples:

**Example 1**

1. 2 pipe bends
  2. 3 meters horizontal pipe
  3. 5 meters vertical /sloping pipe
- Apply Situation A

**Example 2**

1. 3 pipe bends
  2. 4 meters horizontal pipe
  3. 9 meters vertical /sloping pipe
- The situation is not permissible.

**Table 1: Conditions for adjusting the equipment with roof ducts**

G31	total number of meters of horizontal pipe lengths	total number of meters of vertical and/or sloping pipe lengths											
		1	2	3	4	↓5↓	6	7	8	↓9↓	10	11	12
no bends	0	B	C	C	D	↓D↓	E	E	F	↓F↓	F	F	F
2 bends	0	A	A	B	C	↓C↓	D	D	E	↓E↓	F	F	F
	1		A	A	B	↓C↓	C	D	D	↓E↓	E	F	
	2			A	A	↓B↓	C	C	D	↓D↓	E		
	→3→	→	→	→	→A→	A	B	C	C	↓D↓			
	4					A	A	B	C	↓			
	5									↓			
3 bends	0		A	A	B	C	C	D	D	↓E↓	E	F	F
	1		A	A	A	B	C	C	D	↓D↓	E	E	
	2			A	A	A	B	C	C	↓C↓	D		
	3				A	A	A	B	C	↓C↓			
	→4→	→	→	→	→	→A→	→A→	→A→	→B→	-			
	5												
4 bends	0		A	A	A	B	C	C	D	D	E	F	F
	1		A	A	A	A	B	C	C	D	D	E	
	2			A	A	A	A	B	C	C	D		
	3				A	A	A	A	B	C			
	4					A	A	A	A				
	5												
5 bends	-												

■ = The situation is not permissible.

**Table 2:**

Situation	Inlet guide	Damper	Distance damper
A	NO	NO	OPEN
B	YES	YES	53 mm
C	YES	YES	48 mm
D	YES	YES	43 mm
E	YES	YES	38 mm
F	YES	YES	33 mm

**6.5.3.2 Installing the concentric system**

The roof duct can be used for either a sloping roof or a flat roof.

Depending on the intended use, the roof duct will be supplied with either adhesive flashing for a flat roof or a universally adjustable tile for a sloping roof.

Install the concentric system as follows:



- N.B.**
  - Construct the system from the (connection stub of the) appliance up
  - Allow a minimum distance of 50 mm between the outside of the concentric system and the walls and/or ceiling.
  - Use heat-resistant insulating material for ducts made of combustible material.
- Connect the concentric pipe sections and any necessary bends.
- Fit a clamping strip and silicone sealing ring to every connection.
- Secure the clamping strip with a self-tapping screw in places which will be inaccessible after installation.
- Use enough brackets to ensure that the weight of the pipes does not rest on the appliance.
- Determine the remaining length of the roof duct.
- Cut the roof duct to size.
- !N.B.** Be sure to maintain the correct insertion length.
- Connect the roof duct to the concentric pipes.
- !N.B.**
  - Make sure the universal roof tile fits well against the surrounding tiles.
  - Make sure the adhesive flashing sticks to the flat roof properly.

### 6.5.4 Connection to an existing flue

The appliance can also be connected to an existing flue.

A flexible pipe is then inserted into the chimney to discharge the flue gasses. The surrounding space is used to supply the combustion air.

The following requirements apply for connection to an existing flue:

- allowed only if the special DRU chimney connection set is used.
- Installation instructions supplied.
- minimum dimensions 150 x 150 mm;
- maximum vertical length 12 metres;
- maximum horizontal length 3 metres;
- the existing flue must be clean;
- the existing flue must not have any cracks or leaks;

### 6.6 Building the chimney breast

The appliance is designed to be installed snugly into a newly built chimney breast.

There must be sufficient space around the appliance to ensure a good heat distribution.

The chimney breast should be ventilated by vents.

- N.B.**
  - Use incombustible and heat-resistant material to construct the chimney breast, including rear wall of the chimney breast;
  - The total free vent area of the vents, installed as high as possible, should be at least 200 cm<sup>2</sup>.
- !N.B.** When building the chimney breast, the following points should be taken into account (see Fig. 2):
  - position of the control box: this should be placed within 850 mm to the left or right of the appliance, as low as possible;
  - size of the control box; see section 8.2 Installing the control box;
  - position of the vents;
  - the size of the glass window so that it can be fitted/removed once the chimney breast has been built;
  - protecting the gas control block and hoses from cement and plaster.
- !Tip** The vents should preferably be created in both sides of the chimney breast: you could use DRU ventilation elements.

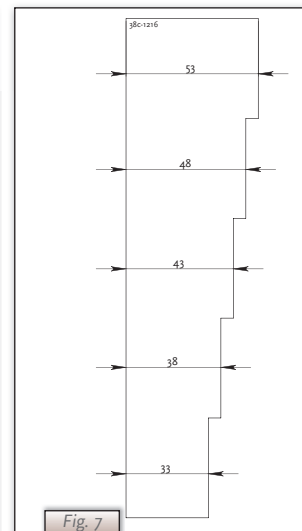
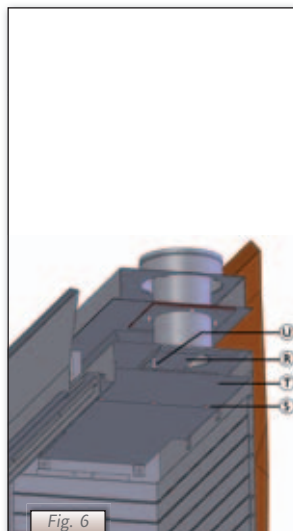
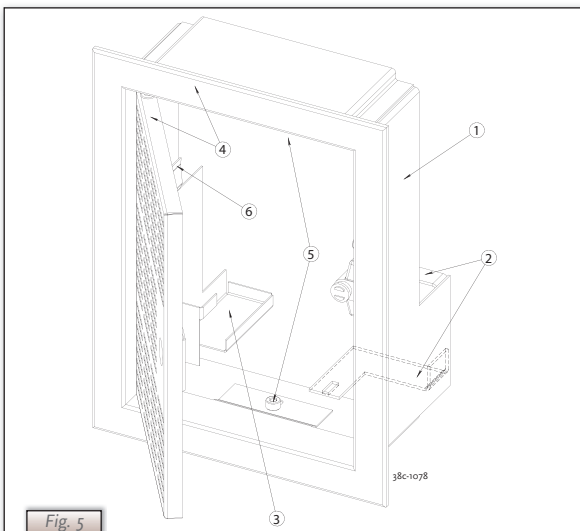

- ⇒ Check that the concentric system has been installed correctly.
- ⇒ Check that the clamping strips have been secured with self-tapping screws in places which will be inaccessible later.
- ⇒ Allow sufficient clearance round the appliance in the chimney breast to enable the heat to disperse:
  - minimum internal height: 1350 mm;
  - minimum internal width: 1010 mm
- ⇒ Do not plaster over the flanges because:
  - the heat from the appliance could cause cracks;
  - it will then be impossible to remove/fit the glass window.
- ⇒ If the chimney breast is made of stone-like materials or has been finished in stucco, it should be left to dry for at least 6 weeks prior to taking it into operation, in order to prevent cracks.

## 6.7 Installing the control box

The control box is to be installed as low as possible.

The control box contains various components such as the type plate, the gas control block, and the receiver for the remote control. (See *Fig. 5* for details.)

- ⇒ Make a 285 x 194 mm (h x w) opening in the chimney breast.

- ⇒ Fit the inner frame (1); to do this unscrew the bolts (5).

- !Tip**
- If the chimney breast is brick, the inner frame can be cemented in during building.
  - For a chimney breast of any other material, glue/cement the inner frame in place or fit it with four countersunk screws

- ⇒ Mount the gas control block on the brackets (2) on the inner frame.

- ⇒ Reconnect the hoses to the gas control block.



**N.B.**

- Avoid kinks in the hoses.
- Tighten the flexible hose and aluminium pipe making sure they are gastight.
- Screw the thermocouple on by hand first and then
- tighten a quarter turn.

- ⇒ Connect the wires of thermocouple 1 to the gas control; see *Photo 1*.

- ⇒ Blow through the gas pipe if necessary.

- ⇒ Connect the gas pipe to the gas tap.

- ⇒ Bleed off the air in the gas pipe.

- ⇒ Fit the receiver (3); see section 7.1 for connections.

- ⇒ Fit the type plate (6);

- ⇒ Fit the outer frame with door (4) to the inner frame using 2 socket cap screws.

- !Tip** You can position the outer frame in such a way that the door opens to either the left or right.

## 6.8 Adjusting the appliance

The appliance should be appropriately adjusted to ensure it works correctly in combination with the flue system.

This may entail fitting a damper and/or removing the inlet guides; see the requirements in Table 1: Adjustment criteria for appliance with wall duct and Table 2: Adjustment criteria for appliance with roof duct.

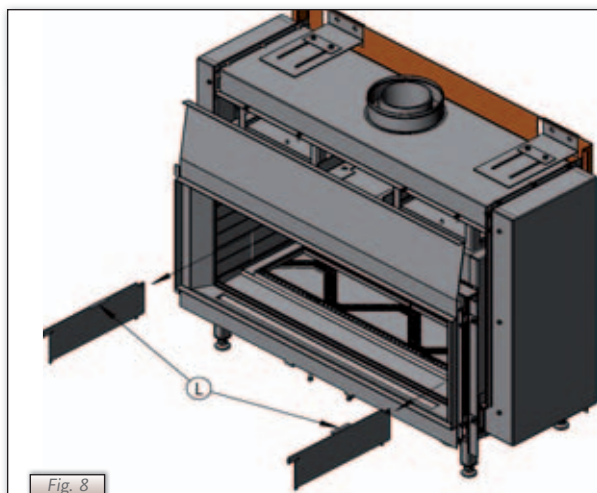
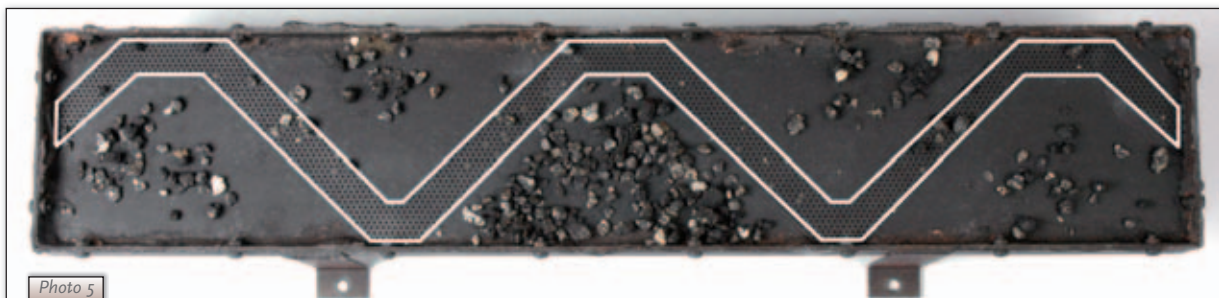
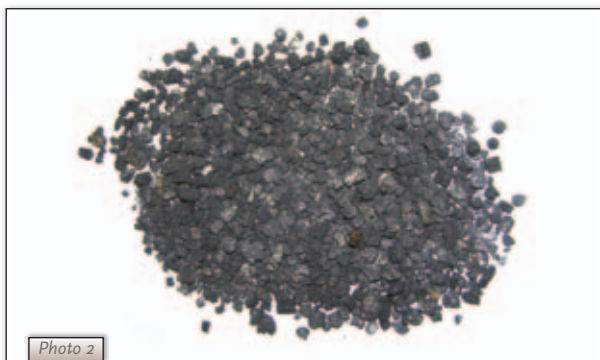

Fig. 8



Photo 1





### 6.8.1 Damper (R)

The damper (R) is packed separately.

This is fitted as follows (see Fig. 6):

- ▣▣▣▣ Unscrew the 6 self-tapping screws in the centre plate.
- ▣▣▣▣ Remove this plate.
- ▣▣▣▣ Fit the damper.
- ▣▣▣▣ Adjust the distance of the damper using the template provided (see Fig. 7):
- ▣▣▣▣ a distance of 33 mm means that the damper is closed as far as possible;
- ▣▣▣▣ use the template to adjust to 38, 43, 48 and 53 mm.
- ▣▣▣▣ Secure the damper in place with the socket-head screw.
- ▣▣▣▣ Replace the centre plate.

### 6.8.2 Air inlet guides (L)

The air inlet guides (L) rest left and right on the sides of the burner tray, see Fig. 8.

- ▣▣▣▣ Remove the air inlet guides if necessary.

## 6.9 Arranging the logs / pebbles

The appliance is supplied with a set of logs or pebbles.



**N.B.**

Observe the instructions below precisely to avoid unsafe situations.

- only use the log/pebble set supplied;
- arrange the logs/pebbles exactly as described;
- make sure the pilot burner and the space around it are kept free from objects (see Photos 9a and 9b);
- make sure that thermocouple 2 and the space around it are kept free from objects (see Photos 10a and 10b);
- make sure that the slot between the burner tray and the tray surrounding the burner is kept free from objects.

### 6.9.1 Logs

The log set consists of vermiculite (see Photo 2), chippings (see Photo 3) and a few branches.

- ▣▣▣▣ Fill the burner tray with the vermiculite, spreading it out evenly.

**!N.B.**

- You can alter the flame effect by moving the vermiculite but
- the burner cap must remain covered by vermiculite to help preserve the useful life of the burner.

- ▣▣▣▣ Fill the tray surrounding the burner with chippings; spreading them out evenly.

- ▣▣▣▣ Identify the branches A-F using Photo 4 for reference.

**!Tip** The burn marks on the branches will help you identify them.

- ▣▣▣▣ Arrange branches A-C around the (main) burner (see Photos 5 and 6):
- First lay branch A symmetrically with respect to the pilot burner;
- Continue with branches B and C.

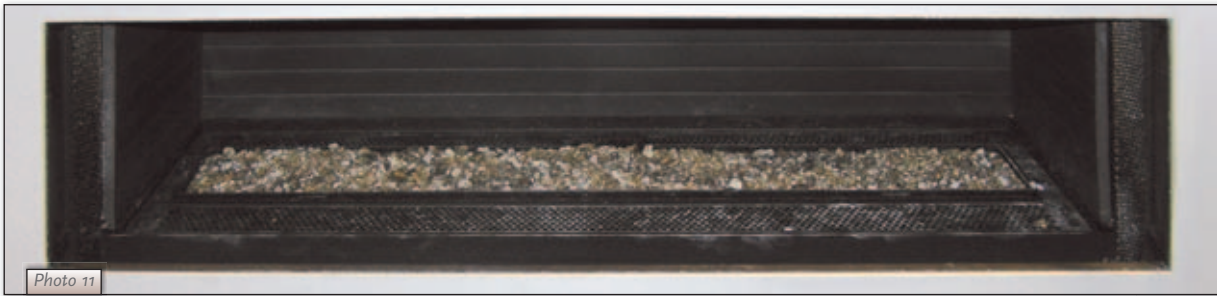

Photo 11



Photo 12



Photo 13

➡ Now lay branches D, E and F (see *Photo 7*).



- N.B.** The branches must not cover the burner cap entirely (see *Photos 5 and 8*) because:
- the main burner will then not ignite properly, which could lead to unsafe situations;
  - soot will accumulate faster;
  - the flame effect will be distorted.

### 6.9.2 Pebbles

The set of pebbles consists of natural coloured vermiculite (see *Photo 2*) and white carrara stones.

➡ Fill the burner tray with the vermiculite, spreading it out evenly (see *Photo 11*).

- N.B.**
- You can alter the flame effect by moving the vermiculite but
  - the burner cap must remain covered by vermiculite to help preserve the useful life of the burner.

➡ Fill the burner tray and the tray surrounding the burner with the carrara stones.

➡ Spread them evenly in a single layer; see *Photos 12 and 13*.



- N.B.** If pebbles on top of each other or otherwise wrongly arranged this could result in:
- the main burner not igniting properly, which could lead to unsafe situations;
  - the flame effect will be distorted.





### 6.10 Glass window

Once the logs have been arranged the glass window can be fitted as described below.

#### 6.10.1 Removing the glass window

Remove the glass frame in accordance with the following instructions (see *Photos 14 to 19*):

- Remove the vertical decorative strips on the left and right of the glass frame by pushing the lip at the top of each strip up, tilting the top of the strip parallel with the glass frame, and then removing the strip.
- Remove the horizontal decorative strip by gripping it with 2 hands in the slot and lifting it out.
- Unscrew the 4 self-tapping screws in the bottom strip using the socket spanner supplied with the appliance.
- Loosen the 3 self-tapping screws in the fastening strips on both sides 2 turns.

**!N.B.** Do not remove the self-tapping screws: leave them in place in the fastening strips.

- Push the 2 top wedges (left and right) down as far as possible.
- Push the 2 bottom wedges upwards as far as possible.
- Press the two fastening strips outwards with your hands as far as possible to avoid damage to the sealing cord.
- Take hold of the top and bottom handgrips and lift the glass frame.
- Pull on the bottom handgrip to tilt the glass frame in its mounting towards you and, at the same time, pull the top of the glass frame towards you as far as possible.

**!N.B.**

- Make sure you hold the upper handgrip firmly. If you let go of the handgrip then the glass frame could fall inwards and cause severe damage to both the glass and the appliance;
- Make sure that you lift the glass frame out of its mounting as straight as possible to avoid damage to the paintwork and the sealing cord.

- Gently allow the glass frame to drop at an angle until it can be removed entirely from the mounting.

### 6.10.2 Fitting the glass window

The glass frame is fitted by using the above procedure, in reverse order.

- !N.B.**
- Avoid/remove fingerprints on the glass, since otherwise they will burn into the surface;
  - The self-tapping screws must not be over-tightened, since otherwise they could break or strip the thread: tight=tight;
  - Replace the fastening strip if the sealing cord has come loose.

Pay attention to the following when fitting the glass frame:

- ▣ Begin by checking that the two fastening strips are pressed outwards as far as possible to avoid damage to the sealing cord.
- ▣ Fit the glass frame.
- ▣ Check that the hook at the top of the glass frame is in position in the seating / U-shaped strip.

**!Tip** Pull on the upper handgrip to move the glass frame towards you: if it does not move, then it has been fitted correctly.

**!N.B.** Fix the glass frame's bottom strip in place with the 4 self-tapping screws.

- ▣ Push both bottom wedges downwards.
- ▣ Push the top wedges upwards until the sealing cord of both fastening strips press against the glass.
- ▣ Tighten each wedge's self-tapping screw.

**!N.B.** Press on the wedge with your hand to hold it in place while you tighten the screws.

- ▣ Tighten the middle self-tapping screw in each fastening strip.
- ▣ Fit the horizontal decorative strips.
- ▣ Fit the vertical decorative strips.

## 7. Wireless remote control

See Chapter 4 of the User Manual, 'Remote Control', for details of how to operate the system.

The remote system consists of a remote control system and a receiver.

The procedure for connecting the receiver has been described below; the working of the remote control system has been explained in detail in Chapter 4, 4.2 of the User Manual 4, 4.2

### 7.1 Receiver

The receiver should be connected to the appliance, before the batteries are installed.

Follow the procedure below (see Photo 21):

- ▣ Fit the connection cable's brown plug to the receiver (see Photo 21, arrow F).
- ▣ Connect the white plug to the gas control.

**!Tip** The plugs have different sizes that correspond with the connectors.

- ▣ Connect the cables of thermocouple 1 to the receiver; (see Photo 21, arrows B).

**!Tip**

- The size of the eye corresponds with the size of the screw;
- The colours of eye and screw also correspond.

- ▣ Connect the black wire with the white plug of thermocouple 2 to the receiver (see Photo 21, arrow E).

**!N.B.** Make sure that the wires of thermocouple 2 cannot come into contact with hot parts

- ▣ Connect the ignition wire to the receiver (see Photo 21, arrow A)
- ▣ Connect the power supply:
  - a) For batteries see section 7.1.1 below;
  - b) For an adapter:
    - connect the adapter to the receiver (see Photo 21, arrow C)
    - plug the adapter into the wall socket.

- ▣ Place the receiver in the control box:
  - Position the receiver as shown in Photo 22

- ▣ Bend the aerial out of the clips, see Photo 21, arrow D.

- ▣ Put the aerial straight up.



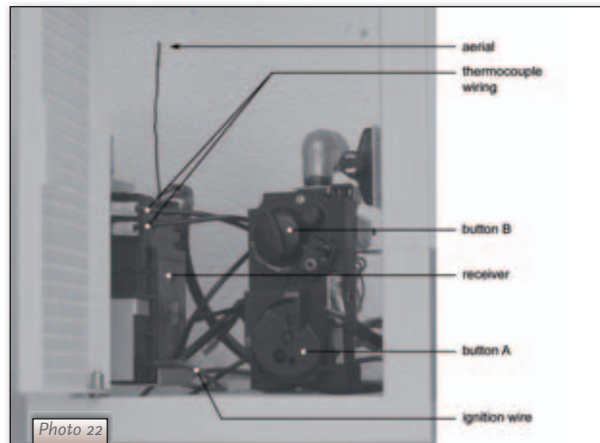
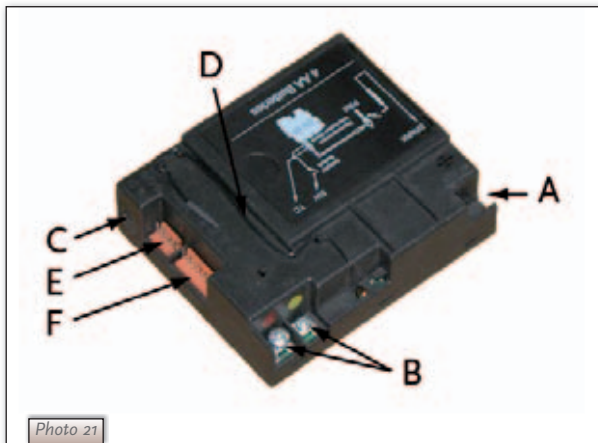

- !N.B.**
- Do not put the aerial too close to the ignition wire and/or metal parts (see *Photo 22* for the correct position)
  - Do not lay the ignition wire across and/or beside metal parts: this will weaken the spark.
  - Do not lay the ignition wire across the receiver: this could damage the receiver.
  - Avoid dust accumulating on or in the receiver: cover it during servicing or maintenance.

### 7.1.1 Fitting/replacing the batteries

To fit the batteries:

- ▣ Open the flap on the control box.
- ▣ Take the receiver.
- ▣ Slide the lid off.
- ▣ Fit or remove the 4 penlight (AA size) batteries.

- !N.B.**
- Avoid short circuits between the batteries and metal objects/components.
  - Note the "+" and "-" positions of the batteries in the holder .
  - Use alkaline batteries.

- ▣ Slide the lid back on.
- ▣ Replace the receiver.

- !N.B.** Do not throw batteries in the dustbin, they are considered "domestic chemical waste" and should be disposed of accordingly.

## 8. Final inspection

To ensure the appliance is working correctly and safely, check the following before use:

### 8.1 Gastightness

-  **N.B.** All connections must be gastight.
- !N.B.** The maximum pressure to which the gas control block may be exposed is 50 mbar.
- ▣ Test the connections for gastightness.

### 8.2 Gas pressure/pre-pressure

The burner pressure is factory adjusted; see type plate. It is not necessary to check the burner pressure.

-  **N.B.** The pre-pressure in house installations should be checked, as they can vary.
- ▣ Check the pre-pressure; see Appendix 2 /Table 5 and Photo 24 for the measuring nipple on the gas control.
- ▣ Contact the gas company if the pre-pressure is not correct.

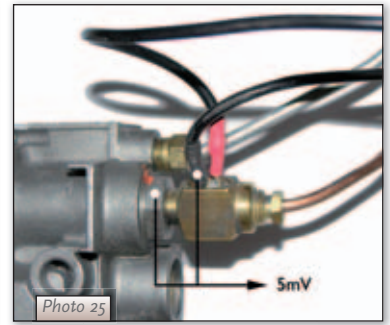
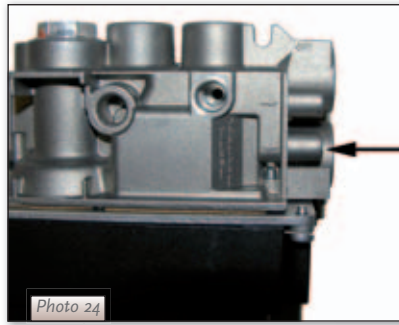

### 8.3 Igniting the pilot and main burner

#### 8.3.1 Pilot

- Test that the pilot ignites properly, see Operating Instructions, section 4.2 Remote control:
  - the pilot burner should ignite at the first attempt.

If the pilot does not light, then

- Check whether or not the ignition sparks:
  - a) If not, the ignition wire is probably touching something metal;
  - b) If it does, there is probably air in the pipes.
- Bleed off any air in the pipes and/or
- Move the ignition wire so that it does not touch anything metal.

#### 8.3.2 Main burner



**N.B.** The burner should ignite evenly and should not pop as a result of delayed ignition.

- Test the working of the main burner from stand-by (pilot) mode; see Operating Instructions, section 4.2 Remote control. once the gas valve has opened the main burner should ignite within a few seconds.

**!Tip** When the gas valve opens the motor will start to run; this is audible.

- 1) If the main burner does not ignite, then:
  - Check that button A on the gas control block is set to ON;
  - Check that the space round the pilot is free;
  - Check that the logs/pebbles have been arranged correctly.
  - Resolve any of the above as necessary.
  - Test the main burner 5 times to ensure it is working properly.
- 2) If the main burner ignites, but goes out again after approx. 22 seconds, please:
  - Check the wiring of thermocouple 2 for:
    - Loose wiring;
    - Wrongly connected wiring;
    - Short-circuit;
    - Broken wire.
  - Check if thermocouple 2 is dirty.
  - Check if thermocouple 2 is positioned correctly in the flame; see Photo 26.
  - Check if thermocouple 2 is defective; see chapter 11, table 4 under J7.
  - Check if the receiver is defective; see chapter 11, table 4 under J8.
  - If necessary, correct the above mentioned faults.
  - Test the main burner 5x for a good operation.

### 8.4 Flame effect

The flame effect cannot really be assessed until the fire has been on for several hours. Volatile elements in paint, materials, etc., which evaporate during the first hours of use, will initially influence the flame effect.

**!N.B.** If the chimney breast is made of stone-like materials or has been finished in stucco, it should be left to dry for at least 6 weeks prior to taking it into operation, in order to prevent cracks.

- Check that the flame effect is symmetrical.
 

An asymmetrical flame effect could be caused by:

  - volatile substances evaporating;
  - incorrectly arranged logs/pebbles.
- Rearrange the logs/pebbles as necessary.

## 9. Maintenance

The appliance should be inspected, cleaned and if necessary repaired by a qualified installer with professional experience of decorative gas fires at least once a year.

The appliance should at least be tested to check it works correctly and safely.

- !** **N.B.**
- Close the gas tap when performing maintenance work;
  - Check the gastightness after repair;
  - After replacing thermocouple 1 you should first tighten the swivel by hand and then give it another quarter turn with a suitable spanner.
- ⇒ Clean the following components if necessary:
- the pilot burner;
  - the space surrounding the pilot burner;
  - the thermocouple 2
  - the glass
- !N.B.**
- Remove the glass as described in section 6.10
  - Remove the deposit on the inside of the glass with a damp cloth or a non-abrasive cleaning product such as copper polish;
  - Avoid/remove fingerprints on the window as they will burn into the glass;
  - Replace broken and/or cracked glass.
- !** **N.B.**
- Replace the logs/pebbles correctly; see section 6.9.
- ⇒ Inspect the flue / combustion air supply system.
- ⇒ Test the system as described in chapter 8.

## 10. Completion

Familiarise the user with the appliance. You should instruct him/her on such things as how to use the appliance and how it works, how to use the remote control, and about the need for annual maintenance.

- !** **N.B.**
- Tell the user to switch off the gas immediately and to contact the installer in the event of a failure / malfunction, to avoid unsafe situations;
  - Show him/her where the gas tap is.
- ⇒ Explain how to use the appliance and the remote control.
- ⇒ Point out that when the appliance is used for the first time:
- If the chimney breast is made of stone-like materials or has been finished in stucco, it should be left to dry for at least 6 weeks prior to taking it into operation, in order to prevent cracks
  - volatile elements in paint, materials etc. will evaporate the first time the fire is used;
  - the fire should preferably be used at the highest setting so that these elements will evaporate more quickly;
  - the room should be well ventilated.
- ⇒ Hand the user the user manual and the installation manual (the installation manual should be kept near the appliance).

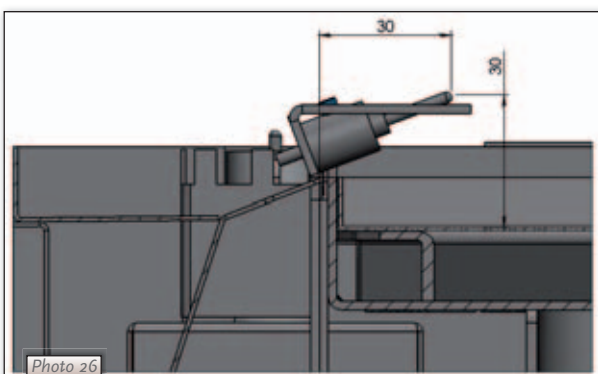



Photo 26

## 11. Troubleshooting

A number of faults which could occur, their possible causes and solutions are shown in the table below:

Table 3: Troubleshooting		
Problem	Possible cause	Remedy
A. No transmission (motor will not run)	<ol style="list-style-type: none"> <li>The (new) communication code between receiver and remote control must still be confirmed.</li> <li>Empty batteries.</li> <li>Receiver is damaged.</li> <li>Remote control is damaged.</li> <li>Motor cable at valve/receiver is broken.</li> <li>Bent pins of the 8-wire connector.</li> <li>If the receiver is surrounded by metal, this could decrease the transmission range.</li> </ol>	<ol style="list-style-type: none"> <li>Hold down the reset button of the receiver, until you hear 2 sound signals; see Photo 23. Let go of the reset button after the second, longer sound signal and press button  (small flame) or button  (large flame) on the remote control within 20 sec., until you hear an extra long sound signal confirming that the new code has been set.</li> <li>Replace batteries. <b>!Caution Avoid short circuit between the batteries and metal parts of the appliance.</b></li> <li>Replace the receiver and confirm the code (remedy 1).</li> <li>Replace the remote control and confirm the code (remedy 1).</li> <li>Replace the motor cable.</li> <li>Make sure that the pins of the 8-wire connector are straight.</li> <li>Change the position of the antenna.</li> </ol>
B. No ignition (spark)	<ol style="list-style-type: none"> <li>Button A in position MAN.</li> <li>Ignition cable runs over and/or alongside metal parts.</li> <li>Ignition pen corroded.</li> <li>60-second delay before the full restart is not yet finished.</li> </ol>	<ol style="list-style-type: none"> <li>Switch button A on the gas control to ON, see <i>Photo 22</i>.</li> <li>Do not place the ignition cable (S) over and/or along metal parts. This will weaken the spark; see <i>Photo 22</i>. If necessary, replace the ignition cable.</li> <li>Replace the ignition pen.</li> <li>Wait until the delay time has passed.</li> </ol>
C. No sound signal	<ol style="list-style-type: none"> <li>Receiver is damaged.</li> <li>60-second delay before the full restart is not yet finished.</li> </ol>	<ol style="list-style-type: none"> <li>Replace the receiver and confirm the code (remedy 1 at A)</li> <li>Wait until the delay time has passed.</li> </ol>
D. One continuous sound signal of 5 sec. (Possible 7 short beeps prior to the 5 sec. sound signal)	<ol style="list-style-type: none"> <li>Loose wiring between receiver and gas control.</li> <li>Receiver is damaged.</li> <li>Bent pins of the 8-wire connector.</li> <li>Damaged magnetic valve.</li> <li>Thermocouple 2 still too hot.</li> </ol>	<ol style="list-style-type: none"> <li>Connect the wiring properly.</li> <li>Replace the receiver and confirm the code (remedy 1 at A)</li> <li>Make sure that the pins of the 8-wire connector are straight.</li> <li>Replace the gas control.</li> <li>Wait until the thermocouple has cooled down sufficiently</li> </ol>

**Table 3: Troubleshooting**

Problem	Possible cause	Remedy
E. No pilot burner flame	<ol style="list-style-type: none"> <li>Air in the pilot burner pipe.</li> <li>Wires of thermocouple 1 have been cross-connected.</li> <li>No spark at the pilot burner.</li> <li>Injector is blocked up.</li> </ol>	<ol style="list-style-type: none"> <li>Flush the pipe or start the ignition process several times.</li> <li>Check the polarity of the thermocouple wiring. Connect the thermocouple wiring properly, if necessary.</li> <li> <ol style="list-style-type: none"> <li>Check if the ignition cable (S) is lying free from metal parts; see <i>Photo 22</i>. If necessary, move it away from the metal parts.</li> <li>If necessary, replace the ignition cable.</li> <li>If necessary, replace the ignition pen.</li> </ol> </li> <li> <ol style="list-style-type: none"> <li>Clean the injector.</li> <li>If necessary, replace the injector.</li> </ol> </li> </ol>
F. Electronics keep sparking while the pilot burner is ignited	<ol style="list-style-type: none"> <li>Receiver is damaged.</li> </ol>	<ol style="list-style-type: none"> <li>Replace the receiver and confirm the code (remedy 1 at A)</li> </ol>
G. Pilot burner is burning, but magnetic valve closes after ca. 10 seconds or when the appliance gets hot	<ol style="list-style-type: none"> <li>Thermocouple 1 does not function.</li> <li>Batteries (almost) empty.</li> </ol>	<ol style="list-style-type: none"> <li> <ol style="list-style-type: none"> <li>Measure the voltage, using a digital multimeter, set to mV range, by connecting the cables to the cable shoe. The cable shoe is located on the outside, directly next to the magnet nut at the rear of the gas control; see <i>Photo 25</i>. The voltage should be at least 5mV within 20 seconds. It may not be lower when the appliance is warm. If the voltage is too low:                             <ul style="list-style-type: none"> <li>- the thermocouple should be placed better in the flame or</li> <li>- the thermocouple should be replaced.</li> </ul> </li> <li>Check the size of the pilot burner flame. Correct a flame that is too small.</li> <li>Check the wiring of the thermocouple to the receiver. If necessary, replace the wiring.</li> </ol> </li> <li>Replace the receiver's batteries. <b>!Caution Avoid short circuit between the batteries and metal parts of the appliance.</b></li> </ol>
H. There are short sound signals, but no sparks and no sound / clicks can be heard of the magnet opening the valve	<ol style="list-style-type: none"> <li>Batteries (almost) empty.</li> </ol>	<ol style="list-style-type: none"> <li>Replace the receiver's batteries. <b>!Caution Avoid short circuit between the batteries and metal parts of the appliance.</b></li> </ol>
I. Pilot burner is burning, but there is no gas flow to the main burner	<ol style="list-style-type: none"> <li>Button A in position MAN.</li> <li>Appliance in the pilot flame position.</li> <li>Pre-pressure of the gas is too low.</li> <li>Damaged magnetic valve.</li> </ol>	<ol style="list-style-type: none"> <li>Turn button A on the gas control to ON; see <i>Photo 22</i>.</li> <li>Increase the flame height by pressing button  (large flame) on the remote control.</li> <li>Check pre-pressure. If necessary, contact gas company.</li> <li>Replace the gas control.</li> </ol>

Table 3: Troubleshooting

Problem	Possible cause	Remedy
J. Main burner ignites, but goes out again after approx. 22 seconds	<ol style="list-style-type: none"> <li>1. Wiring of thermocouple 2 is loose.</li> <li>2. Wires of thermocouple 2 have been cross-connected.</li> <li>3. Short-circuit in the wiring of thermocouple 2.</li> <li>4. Broken wire in the wiring of thermocouple 2.</li> <li>5. Thermocouple 2 is dirty.</li> <li>6. Thermocouple 2 is not positioned correctly in the flame (see <i>Photo 26</i>.)</li> <li>7. Thermocouple 2 is defective.</li> <li>8. Receiver is defective.</li> </ol>	<ol style="list-style-type: none"> <li>1. Connect the wiring properly.</li> <li>2. Connect the wiring properly.</li> <li>3. Replace wiring.</li> <li>4. Replace wiring.</li> <li>5. Clean the thermocouple.</li> <li>6. Position the thermocouple correctly in the flame.</li> <li>7. Check the voltage across thermocouple 2 just before the main burner goes out. If the voltage is lower than 1.8 mV, replace thermocouple 2.</li> <li>8. Check the voltage across thermocouple 2 just before the main burner goes out. If the voltage is higher than 1.8 mV, replace the receiver.</li> </ol>

## Annex 1 Components supplied

The table below specifies the components supplied with the appliance.

Table 4: Components supplied		
Component	Quantity	Order number
Set of Logs/Pebbles	1x	22491 / 22483
Control box	1x	26280
Control box manual	1x	957.577.06
Installation manual	1x	959.002.05
User manual	1x	958.010.00
Trim left/right	Metro 70 2x Metro 70 Tunnel 4x	38724174
Trim bottom	Metro 70 1x Metro 70 Tunnel 2x	38741302
Damper template	1x	38714165
Damper	1x	38741224
Rawplugs M8x14x50	2x	509330
Hexagonal nut M8	4x	521308
Washer 8.4 mm	4x	525070
Spare self-tapping screws for the glass window		
Socket spanner 8 mm	1x	790811
Remote control with receiver	1x	806277
9V square battery	1x	923001
Penlight battery (AA type)	4x	923100
Pressure coupling 15 mm x G3/8"	1x	149234

## Annex 2 Technical data

The technical data for the Metro 70/ Metro 70 Tunnel are given in the table below.

Table 5: Technical data				
Type		C11/C31		Pre-pressure (mbar)
Gas type		G31		G31
Burner pressure	mbar	28.5	NL	30
Nominal Load (Hs)	kW	6.6	BE	37
Nominal Load (Hi)	kW	6.0	FR	37
Nominal Capacity	kW	4.3	DE	50
Consumption	L/h	245	AT	50
Burner jet	mm	2x Ø 0.95	CH	37
Consumption on stand-by	L/h	163	GB	37
Fine adjustment jet	mm	Ø 1.20	IE	37
Pilot jet	Code	30	NO	30
Efficiency category		2	PT	37

## Annex 3 Spare parts

Spare parts are available from [www.druserice.nl](http://www.druserice.nl)

