

ERU-5000 COMBINED TABLE

OPERATION MANUAL



I .Introduction:

1. Product introduction:

Combined Table ERU-5000 is a combinatorial system which could be used together with Auto Refractometer, Phoropter, Keratometer, Slit Lamp, and Chart Projector. It makes the whole system work more conveniently and accurately. Sliding table accommodates two instruments and provides with 90 degrees' rotation; Hand-operated phoropter arm can swing up and down, left and right; Reclining Chair can smoothly lift up and down, forward and backward with low noise. It can be used with kinds of ophthalmic instruments, and it's the ideal choice for hospitals, clinics and optical shops.

II .Safety:

1. Safety symbols and illustration

2. The use of environment and Notes

- 1) Read and understand all instructions.
- 2) Operation should accord to the fuselage warnings and instructions.
- 3) Please do not place or use the equipment near water, do not use or place the equipment in wet areas.
- 4) Keep the instrument on smooth ground. Otherwise, the falling of the unit can cause serious damage or injuries.
- 5) For safety, the machine has ground plug. If you have no such outlet, please install. Do not use the adapter; otherwise, it will cause abolition of the security features.
- 6) When equipment is installed, please check the installation correctly, and then access the total power, cut off the power for a long time of stop using.
- 7) When cleaning the equipment, please unplug the power cord of the machine. Use a wet cloth to clean, access to power supply when fully dry. (Do not clean the inside part)
- 8) When there is failure or abnormal phenomenon during the use of this instrument, please cut off the power immediately and contact us, do not maintain personally.
- 9) According to the principle of this product, work methods and features, no need to do disinfection and radiation protection.

Contents

I .Product Introduction.....	3
1.Main Engine.....	3
2.Detailed explanation of Operation panel	3
II .Instruction	4
1.Installation	4
2.Adjustment.....	8
3.Testing and Operating.....	8
III. Maintenance.....	9
1. Daily maintenance.....	9
2. Replacing accessories.....	9
3. Cleaning.....	9
4. Notes of moving machine.....	9
5. Service.....	9
IV. Malfunction and Exclusion.....	9
1. The specifications of fuses:	9
2. The method of changing fuses.....	9
V. Specifications.....	10

I .Product Introduction

1.Main Engine

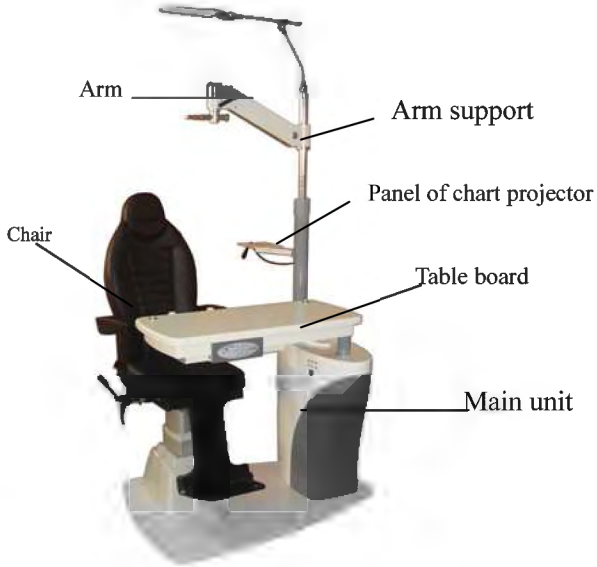

2. Detailed explanation of Operation panel

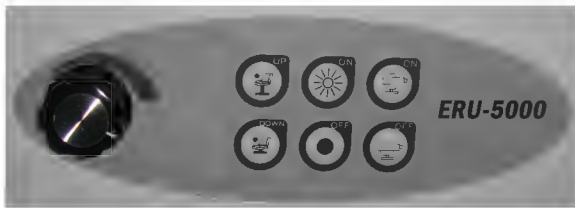

II .Instruction

1. Installation (Make sure the installation space: 5m*2m*2.4m)

Steps: 1) Removable with scissors carton packaging tapes, remove the carton and side panels

2) Take off the packing material, take out the chair, and remove the fixed screws which are used to fix the main unit with a spanner.

3) Take out the main unit from the wooden pallet. (See Figure 1)

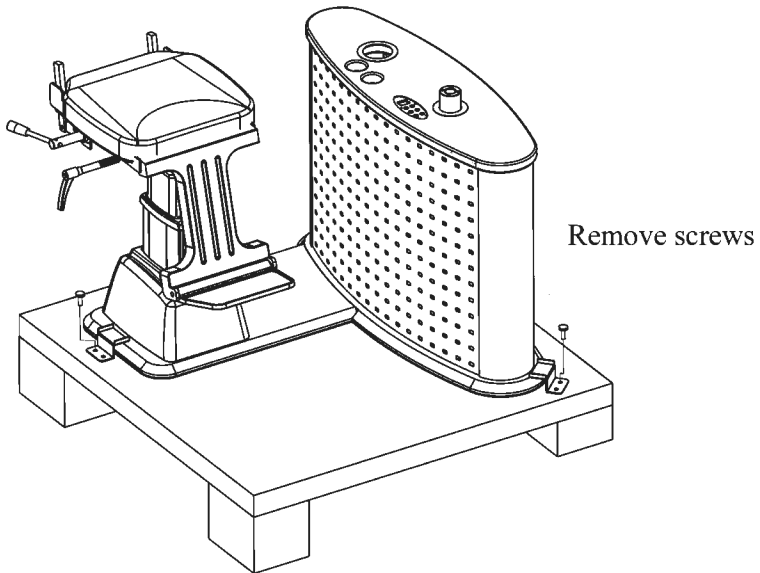

Figure.1

4) Installation of chair: Correspond the holes on the chair and the chair stand, fix them with screws. (See Figure.2)

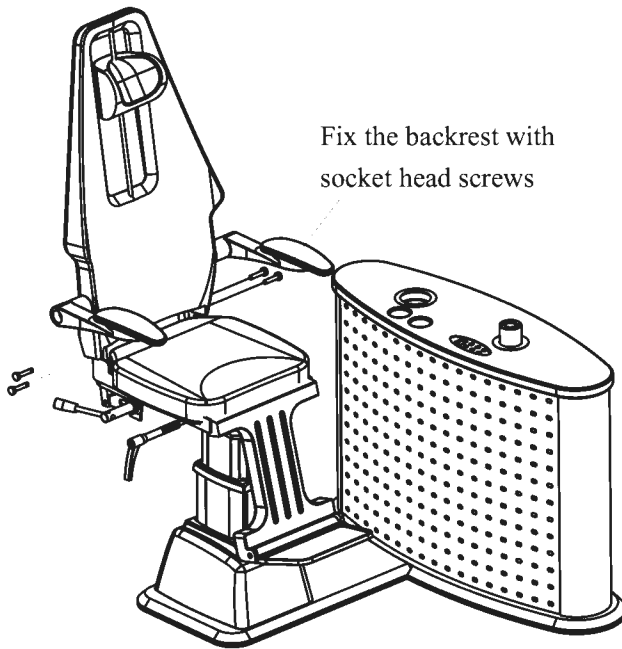

Figure.2

- 5) Take off the packing material, take out the table, arm, arm stand and the accessories.
- 6) Installation of arm support: first assemble the panel of chart projector on the arm support, connect the connectors under the arm support(arrange the wires orderly), install the arm support on hole of the main unit, open the side panels and fix the arm support tightly with screws, at last cover the side panels.(See figure.3)
- 7) Assemble the phoropter arm on the arm support and fix it with screws. (Attention: 1. The limit situation of arm rotation; 2. Make sure the cover of arm and fixed parts be tightly locked) (See figure.4)

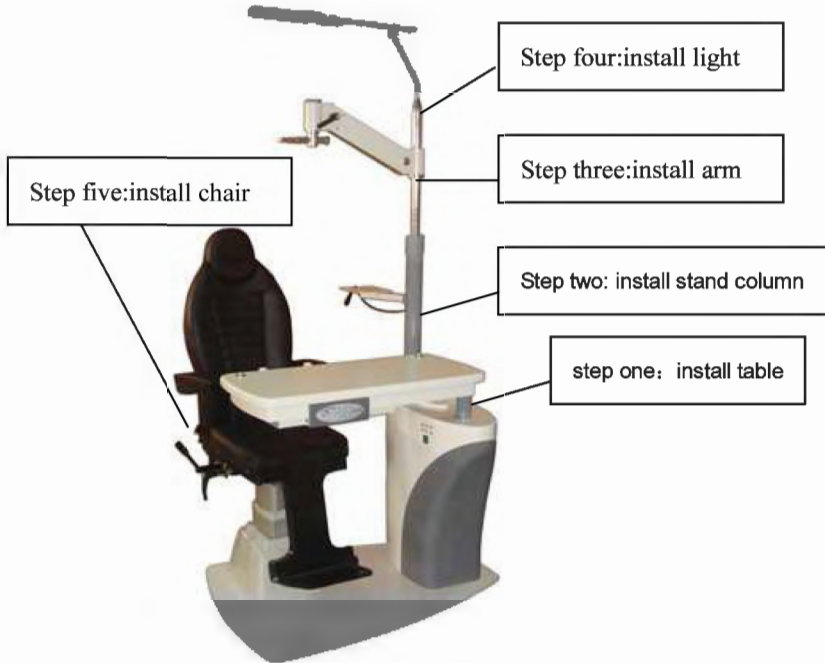

Figure.3

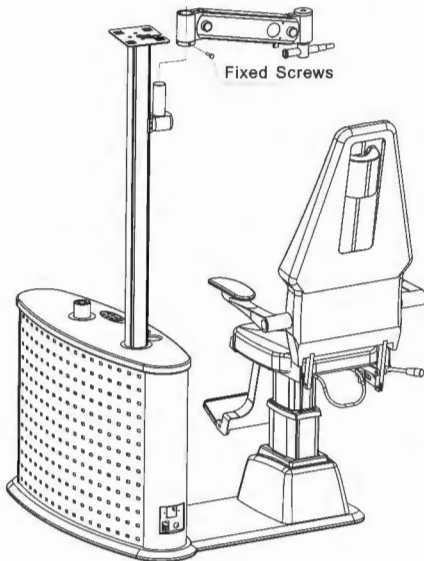

Figure.4

8) Installation of the table: connect the wires under table support and the wires from Axis of rotation following rotation, connect the table support and the Axis of rotation with screws, install the wires cover and table support in the grooves which under the table support. (See Figure 5)

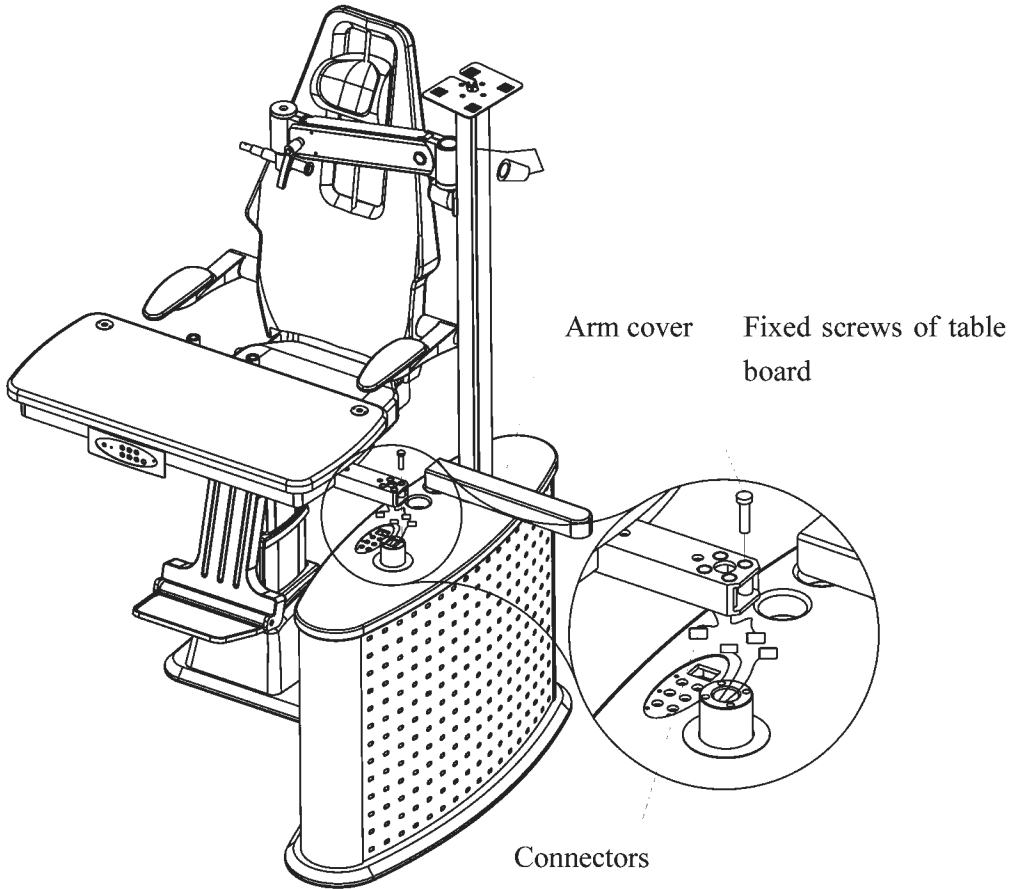

Figure.5

2.Adjustment

- (1) Check if the main engine is placed stable
- (2) Turn the power switch, power indicator light lights
- (3)Table rotation smoothly and flexibly and sliding (total range is 90 degrees)
- (4)Arm swings and rotates smoothly, and quietly, and can be locked.(Total range is 90 degrees)
- (5)Turn on the light and it can work normally
- (6)Check if the chair is steady, turn on the power switch of chair, it can up and down smoothly and quietly(Total range is :15cm) (When chair up, press the limit switch, the chair will stop)
- (7)Check if the power socket for Slit Lamp, Keratometer and Auto Refractometer is ok.

3. Testing and Operating

- 1) Rotate the table 90 degrees counterclockwise; let the patient sit on the chair.
- 2) Rotate the table 90 degrees clockwise in front of patient; to check if you can use Auto Refractometer correctly.
- 3) Turn on the Chart Projector to test the power (Please refer to the operation manual of Chart Projector)
- 4) Swing arm manually, put the phoropter in front of patient's eyes, placed inspectors, adjust the chair to suitable height, after using it, and reset it.
- 5) Rotate the table 90 degrees counterclockwise, press the down button of chair, lift down to suitable position, to make it suitable for patient to leave.
- 6) Switch off the power, unplug the power cord if don't use for a long time.

III. Maintenance

1. Daily maintenance

If you don't use equipment frequently, turn off the power switch. Check Power line regularly, if it's damage or aging.

2. Replacing accessories

There is no need to replace consumables frequently, when abnormal situation occurs, such as fuse burns, replace the appropriate fuse type

3. Cleaning

When cleaning the equipment, please unplug the power cord of the machine. Use a wet cloth to clean, access to power supply when fully dry. (Do not clean the inside part) Do not clean the power outlet with wet cloth.

4. Notes of moving machine

Please pull out the power plug when moving the unit, ensure that all power is cut off. Other equipments shall be removed to ensure that no parts will fall down. Protect wires been not broken when moving.

5. Service

If anything abnormal during use, first cut off the machine power, then telephone sales company or service points for consultation

IV. Malfunction and Exclusion

1.The specifications of fuses:

- a) Power Supply:AC220V/110V Input fuses: F3A (5×20) mm 2pcs
- b) Power Supply of Chair: F6A (5×20) mm 1pc
- c) External Socket AC220V: F2A (5×20) mm 1pc

2.The method of changing fuses:

- a) Switch off power supply, Unplug the power cord;
- b) Take off the fuses by removing the fuse cap with a screwdriver;
- c) Put the same size fuse, revolve the fuse hat clockwise, replace the fuse.

V. Specification:

ERU-5000 Products Features:

- A. Class: class I
- B. Type: B-
- C. Equipment belongs to common type
- D. Equipment doesn't belong to type AP or APG
- E. Equipment operation: continuous operation
- F. Non-permanent equipment (mobile device)

Unit size: 1190*1055*1850mm

Table Size: 890*405mm

Table rotation range: 90°

Table movable range: 335mm

Swing arm oscillation angle: +35°

Chair rotation range: 60°

Chair up and down range: 540-690mm

Chair loading ability: 200-250kg

Chair backrest obliquity: 160°

Lamp: LED (24V, 3W)

Electric Voltage: AC220V/110V 50/60HZ

Weight: 200kg