



Alphacom a300

a RANGE HEADSETPHONE

USER GUIDE

Versatility & Value

CONTENTS

	Page
1. GUARANTEE	2
2. CONDITIONS OF USE	2
3. FACILITIES AND FEATURES	3
4. LOCATIONS OF CONTROLS - FRONT VIEW	4
5. LOCATIONS OF CONTROLS - SIDE VIEW	5
6. HEADSET HOOK ASSEMBLY - (optional)	6
7. UTILISATION OF CONTROLS	7
8. INSTALLATION	8
9. SETTING THE DIALLING AND RECALL MODE	8
9.1 THE DIAL MODE SELECTOR SWITCH	8
9.2 THE RECALL MODE SELECTOR SWITCH	9
9.3 NETWORK SERVICES	9
10. CONNECTING TO TELEPHONE SOCKET	10
11. SETTING THE CLOCK	10
12. SETTING THE RINGER	10
13. WALL MOUNTING	10
14. OPERATING PROCEDURES	11
14.1 HANDSET OPERATION	11
14.2 HEADSET OPERATION	11
14.3 HANDSFREE OPERATION	12
14.4 LAST NUMBER REDIAL	12
14.5 AUTO REDIAL FEATURE	13
14.6 MEMORY OPTION	13
14.7 STORING NUMBERS WHILST ON A CALL	14
14.8 PROGRAMMING CODES FOR CENTREX & NETWORK SERVICES	14
14.9 CHANGING A NUMBER IN A MEMORY LOCATION	14
14.10 DIALLING NUMBERS FROM MEMORY	14
14.11 PAUSE FACILITY	14
14.12 MIXED DIAL MODE OPERATION	15
STORING MIXED DIAL MODE NUMBERS	15
14.13 RECALL BUTTON	15
14.14 AUTO CALL TIMER	16
14.15 * AND # BUTTONS	16
14.16 HANDSET MUTE BUTTON	16
14.17 BASE UNIT LATCHABLE MUTE	16
14.18 SAVE FUNCTION	16
15. OPERATING PROCEDURE FOR PBX CONNECTION	17
15.1 PBX RECALL	17
15.2 PABX PAUSE FACILITY	17
15.3 MESSAGE WAITING OPERATION	17
15.4 GENERAL USE	17
16. IN CASE OF DIFFICULTY	18
17. CARE OF YOUR a300 HEADSETPHONE	18

1. GUARANTEE

Your Executive a300 Headsetphone is guaranteed from the date of purchase. If found to be faulty within the guarantee period it will be repaired or replaced at our discretion, subject to our standard terms and conditions. The guarantee does not cover accidental damage or negligence. The telephone must only be used in the U.K. in accordance with its instructions for use and must not be tampered with, or taken apart by anyone who is not an authorised representative of the company. The guarantee in no way limits your legal rights. Should you have any problems, please return your telephone to your supplier.

Please ensure that a note of your name and address and details of the problems are enclosed, together with a copy of your purchase invoice, and that goods are returned in their full original packaging with instructions enclosed. Goods are returned to the manufacturer at the customer's own risk and expense.

2. CONDITIONS OF USE

Your a300 Headsetphone is approved for use on business or private direct exchange lines and on compatible PBX extensions.

When connected to a direct exchange line this must be a standard exclusive (not shared service) line. The line should cater for either loop disconnect or multifrequency signalling. The telephone can signal Timed Break and Earth Recall.

This telephone is not suitable for use as an extension to a payphone or on shared service or (1+1) carrier systems.

The dialling code '999' can be dialled on this apparatus for the purposes of making outgoing calls to the BT Emergency (999) Service.

3. Facilities and Features

This apparatus has been approved for the use of the following facilities

- Simple telephone facility with headset operation
- Loop Disconnect or DTMF Signalling (selectable)
- Mixed Mode signalling
- 10 + 10 Direct memory locations of 24 digits capacity
- Memory protection switch
- Earth Loop and Timed Break Recall.
- Handset push to mute facility or optional push to speak (in handset mode only)
- Base unit latchable mute, with LED indication.
- Wall or Desk mountable.
- Full 'HANDS FREE' operation with volume control and LED indication.
- Ringer OFF/LO/HI control
- Ringer pitch control
- Pause entry in dialling sequence.
- 16 digit LCD showing real and call elapsed time and dialled telephone number
- Auto call timer.
- Auto redial (10 fixed time)
- Message waiting.

Any other usage will invalidate the approval of the apparatus if as a result it then ceases to conform to the standards against which approval was gained.

a300 Headsetphone - front view

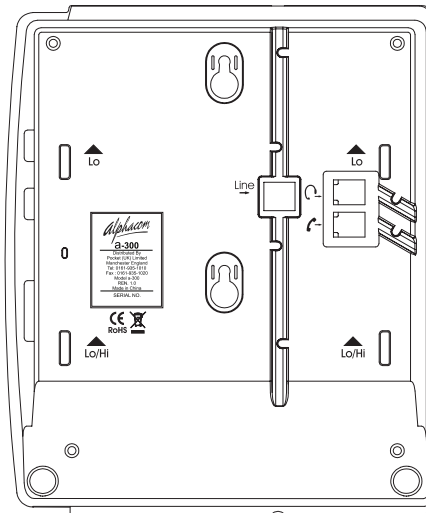
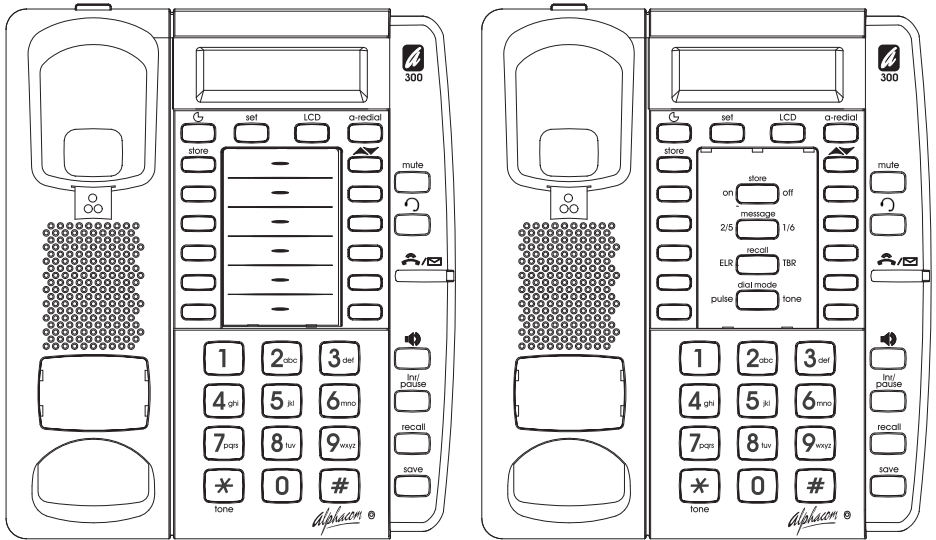

a300 Headsetphone - side view

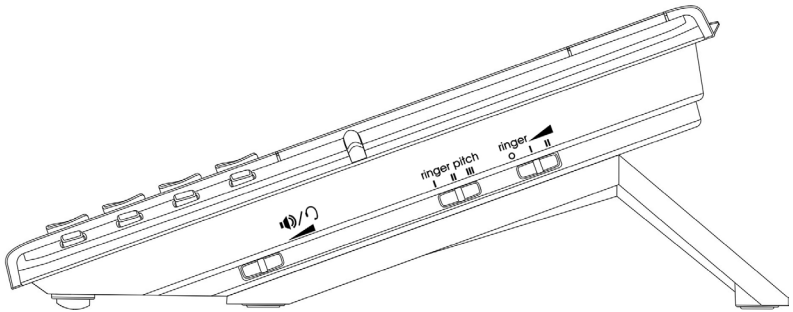
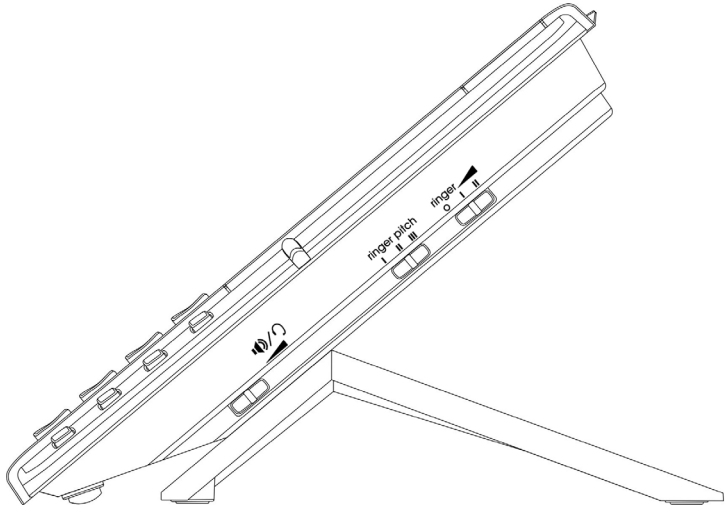

6. Headset Hook Assembly (Optional)

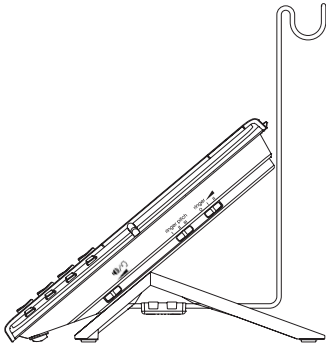

Hi Elevation

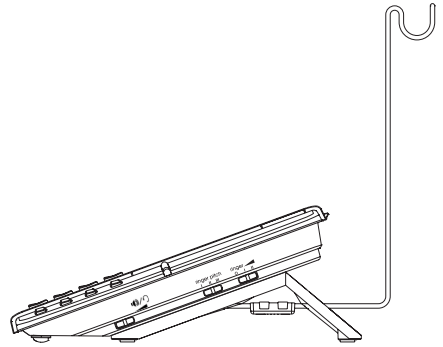

Lo Elevation

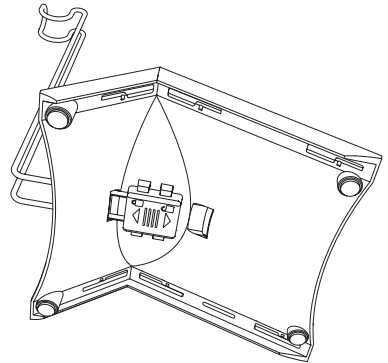
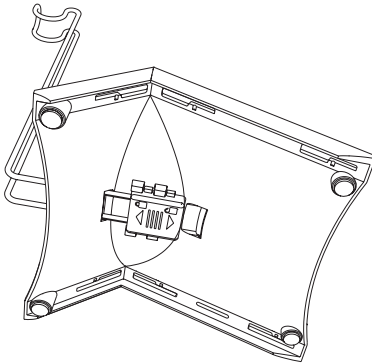

Position the Headset Hook in the required elevation (Hi or Lo) then slide the cover on to secure in place.

7. Utilisation of Controls

The button functions are as follows:

- 0 - 9 - Dialing digits.
- * - # - Dialling codes for MF signalling
- Recall - For use on PBX or for star services
- Save - Used to store the last number in a memory
- Tone - Switches from Loop Disconnect to DTMF during dialling
- Redial - Last number redial
- Pause - Insert a pause in the dial sequence
- Store - Used to store a telephone number in memory
- Mute (on handset) - To prevent the other party from hearing you (ie. push (on handset) down to mute) or, alternatively, on specially adapted models this can be amended to push-to-speak. In this instance, the phone will be clearly marked as such.
- Latchable Mute - To prevent the other party from hearing you (i.e. push (on base) to mute). LED will illuminate when in use. Push button again to continue normal (two-way) conversation.
- Headset - To enable headset operation, LED will illuminate when in use.
- Auto Redial - Activates re-dialling to a previously engaged number.
- Time - You can check the last number dialled and the conversation time.
- Shift - To select memories 11-20.
- Set - Use to set clock
- LCD - Use to set LCD Display Contrast
- Speaker - To enable handsfree dialling, LED will illuminate when in use.
- Auto Redial - 10 times Auto Redial (operate with batteries installed).

The switch functions are as follows:

- Ring Vol - Allows you to set the level of the ringer loudness
- Ring Pitch - Allows you to set the pitch of the ringer
- ELR/TBR - Sets the Recall to Earth (ELR) or Timed Break (TBR) Recall
- Pulse/Tone - Sets signalling (dialling) to Loop Disconnect (LD) or DTMF(MF)
- Store On/Off - Allows you to protect numbers stored in memory location
- Message Waiting - Sets the message waiting to 4 or 6 line configuration
- Vol. (Slide) - Allows you to set the headset and speaker volume.
- Visual Indicators: Ring - This indicates an incoming call by lighting up.
- Message Waiting - Operates where PABX message waiting is operational
- Headset Socket - Used to connect the headset (not supplied)

8. Installation

The telephone must be sited close to one of the new modular telephone sockets. There is no limit to the number of sockets you can have installed in your home which means you can, if you wish, move your telephone from room to room. Unlike sockets, however, there is a limit to the number of telephones you can operate on your exchange line. Installing too many telephones will overload the line which could inhibit some or all of the telephones from ringing. To avoid overloading your exchange line there is a method of calculating the number of telephones you can use. Add all the Ringer Equivalence Numbers (REN) together, which are marked on the base of each telephone. Numbers differ so do check. The numbers when added together must be 4 or less. Sometimes BT telephones are unmarked but they can generally be assumed to have a REN of 1.0. If in doubt, please check with your BT Sales Office. The REN value of your a300 Headsetphone is 1.0.

9. Setting the Dialling and Recall Mode

The settings must be carried out BEFORE connecting the telephone to the telephone socket. Please note that batteries are not supplied with the unit.

Remove the battery compartment cover on the underside of the base by removing the screw and sliding back the cover. N.B. The telephone must be disconnected from the line before removing the battery cover. Fit 2 size M (or equivalent) leakproof alkaline batteries observing correct polarities. The batteries support information in the memories.

Note: If the Auto Redial function does not operate, you need to replace the batteries.

Two preset switches will be found situated underneath the memory card inlay. These are the DIAL MODE SELECTOR SWITCH and RECALL MODE SELECTOR SWITCH and should be set as follows:

9.1 THE DIAL MODE SELECTOR SWITCH

BT are replacing all local exchanges with new 'TONE' dialling digital systems. They will give improved clarity and reliability and with 'Touch Tone' signalling telephones, instant connection of calls over digital exchanges and a host of advanced features. However some telephone exchanges in the U.K. still operate on the PULSE dialling system. Your a300 Headsetphone series telephone allows you to operate on either system and the DIAL MODE SELECTOR SWITCH should be set to the dialling mode required by your exchange. Set the switch to the PULSE position for pulse dialling or to the TONE position for tone dialling. If in doubt about the correct dialling mode used by your exchange, please consult your Network Operator.

9.2 THE RECALL MODE SELECTOR SWITCH

If you are connected to a TONE dialling exchange, set the switch to the TBR (Timed Break Recall) position to enable you access certain Network Services.

If you are connected to a PULSE dialling exchange, set the switch to the ELR(Earth Loop) position as recall has no function on direct lines connected to such exchanges. (This will avoid the possibility of cutting off your call should the recall button be pressed accidentally.)

If you are connected to a PABX, set the switch according to the requirements of your particular PABX. If in doubt, consult your PABX Instructions or your PABX maintainer.

Having installed the batteries and set the switches, refit the battery compartment cover ensuring that it is screwed fully into place.

9.3 NETWORK SERVICES

BT are replacing all local exchanges with new digital systems. They will give improved clarity and reliability and with Tone signalling telephones, instant connection of calls over digital exchanges and a host of advanced features.

If you are on a digital exchange, you can instruct it to ring you back with the cost of your call. Or you can use it to set up reminder calls, where the exchange rings you at a time you specify.

You can even instruct the exchange to divert your incoming calls to another number, or deal with two calls at once, or set up a 3-way call.

These services are called Network Services: to use them you need a tone signalling telephone. To find out if you are on a digital exchange, or when it will be provided, contact your local BT office.

Your a300 Headsetphone provides tone signalling when the Dial Mode selector switch is set to the (TONE) position and the Recall Mode selector switch is in the TBR position.

If your system requires PULSE dialling, you can change to TONE dialling once the call has been established by pressing the TONE button. This enables you to access special services such as Banking etc. which require access digits to be transmitted in TONE mode. It is important to wait for the call to be established before keying in the access digits. On completion of the call, the telephone will revert to PULSE dialling.

*TouchTone is a trademark of BT in the U.K.

If you are connected to a PABX, set the switch according to the requirements of your particular PABX. If in doubt, consult your PABX Instructions or your PABX maintainer.

10. Connecting to Telephone Socket

When the setting up instructions have been completed, connect the plug at the end of the telephone lead into the telephone socket. The plug will only fit the correct way round.

11. Setting the Clock

1. Lift up the Handset or press the Handsfree button
2. Press Set button, the month setting flashes in the display
3. Press * KEY repeatedly to select the correct month
4. Press # KEY to confirm the setting. The Day setting will then flash in the display
5. Press * KEY repeatedly to select the correct Day
6. Press # KEY to confirm the setting. The Hour setting will then flash in the display
7. Press * KEY repeatedly to select the correct Hour
8. Press # KEY to confirm the setting. The Minutes setting will then flash in the display
9. Press * KEY repeatedly to select the correct Minutes
10. Press SET key again to confirm the setting
11. Replace the Handset in the cradle or press Handsfree button to disconnect the line. After approximately 6 second the Date/Time will be displayed

12. Setting the Ringer

RINGER OFF/LO/HI switch.

Set the switch to the LO or HI position as desired to give a quiet or loud ring. The Ringer may also be switched OFF by setting the switch to the OFF position. Outgoing calls may still be made with the switch set to the OFF position.

RINGER PITCH switch.

Set the switch to the HI, MED or LO position to adjust the pitch of the ringer.

13. Wall Mounting

You may wish to mount the a300 Headsetphone on a wall.

To do this:

- Slide the plastic, "wall mount" upwards to remove, turn it around and replace it in the slot.
- The Handset will then stay in the cradle when the telephone is on the wall.
- Position screw into the wall ensuring that the screw head is 5mm from the wall.
- Place the telephone on the screw using the keyhole slot on the rear of the telephone.

14. Operating Procedures

Three modes of operation are provided; normal handset mode where the handset is lifted and replaced in the normal manner, headset mode where conversation is conducted through the headset and handsfree mode where the caller or called party is heard through a loudspeaker built into the telephone and a microphone (again built into the telephone) picks up your voice.

When making or receiving a telephone call, you can alternate among the three modes of operation.

On dialling the required telephone number, the display will change to indicate the dialled number. After a short period of time, the display will show, Auto Timer. If the number has more than 16 digits, the display will scroll to the left and only the last 16 digits of the number will be shown. When the call is completed the display will revert to current time.

The display shows:



14.1 HANDSET OPERATION

Pick up the handset and if making a call, await dial tone and dial the required telephone number. On completion of the call, replace handset in cradle.

14.2 HEADSET OPERATION

HEADSET BUTTON

Using the headset button, you can make calls via the headset without having to move the handset to do so. By pressing the headset button you can obtain a line, answer an incoming call or disconnect the current call.

IMPORTANT

Calls can be transferred from the handset to the headset only if a headset is connected to the telephone.

HEADSET 'ON' LED

While calls are being made using the headset, the headset 'ON' LED lights up to indicate that a call is in progress. The light goes out if no calls, or calls using the handset, are being made.

HEADSET VOLUME CONTROL

A headset volume control on the right hand side of the telephone allows you to select the most comfortable listening volume for the headset. The volume can be set or changed at any time.

TRANSFERRING CALL FROM HANDSFREE TO HEADSET

To transfer a call from Handsfree to Headset, press the Headset button, the LED on the Headset button will illuminate. When in headset mode, pressing the speaker button once will transfer the call to handsfree mode.

TRANSFERRING CALL FROM HANDSET TO HEADSET

To transfer a call from Handset to Headset, press the Headset button, the LED on the Headset button will illuminate. To transfer a call from headset mode to handset, simply pick up the handset from the cradle.

14.3

HANDSFREE OPERATION

When the telephone rings, press the Speaker button and commence your conversation speaking at a comfortable distance of about 35 cms from the telephone. Adjust the volume of sound by means of the VOLUME CONTROL. To make a call, press the speaker button, await dial tone and dial the required telephone number. On completion of the call, press the Speaker button to clear down the line. To change from HANDSFREE mode to HANDSET MODE, pick up the handset. Replacing the handset in the cradle will clear down the line when you have completed the call. To change from HANDSET MODE to HANDS FREE MODE, press the speaker button and replace the handset in the cradle. Pressing the Speaker button again will clear down the line when you have completed the call. During HANDS FREE mode, the LED indicator will light up.

14.4

LAST NUMBER REDIAL

If the telephone number you have called is engaged or if you want to repeat the call to the number you dialled previously, lift the handset or use the handsfree mode, or headset mode, await dial tone and press the REDIAL LNR button. The previously dialled number will be RE-DIALLED. Up to 32 digits can be stored in the REDIAL LNR memory. The re-dialled number will appear in the display. If the number contains more than 16 digits, only the last 16 will be displayed.

14.5

AUTO REDIAL FEATURE

If the telephone number you have called is engaged and you want to keep on dialling until the call is answered.

1. Press Speaker button to get the line, the LED indicator will illuminate.
2. Press the Auto Redial button, the dialled telephone number will be automatically dialled out. The dialled number will blink on the display and the line status can be monitor through the Speaker during 30 seconds waiting period.
3. If the call is answered during 30 seconds waiting period, you can answer the call by lift up the Handset or press any key on the telephone except Speaker button to use Handsfree operation.
4. If the call is not answered during 30 seconds, the line is disconnected by 30 seconds break period. During the 30 seconds break period, the telephone number will show steadily on display and the Speaker button indicator will turn off.
5. After the 30 seconds break period, the telephone number will be automatically dialled out again as described in step 2.
6. The Auto Redial process will be repeated for 10 times until the call is answered or you can terminate the function by pressing the Speaker button during the break period as you wish.
7. Auto Redial can also work in headset mode. By pressing the headset button first to get the line then pressing the auto redial button. The operation is similar to that in handsfree mode

14.6

MEMORY OPTION

Up to 20 telephone numbers each consisting of a maximum 24 digits (including pauses or change of dial mode instruction).

Alternatively you may store 10 telephone numbers plus 10 access codes for Network Services which your service provider has enabled.

Two banks of memory are provided, labelled 1-10 and 11-20 (the appropriate bank being selected by pressing the SHIFT button and symbol “J” will show on display).

To store a number, please adopt the following procedure:-

1. Ensure the Memory Protection Store switch is positioned to the left.
2. Seize the line in any mode.
3. Press STORE button once, and the symbol “E” shows on display.
4. Key in the telephone numbers you want to store.
5. Press SHIFT button if upper memory location are required.
6. Press desired memory location button.
7. Release the line from any mode.
8. To protect the number stored ENSURE that the Memory Protection Store switch is positioned to the right.

14.7 **STORING NUMBERS WHILST ON A CALL**

Numbers may also be stored when you are actually in the process of making a call and using the handset. This is useful, for example, if you are given a telephone number during your conversation. The number may then be dialled from memory at a later time. To store the number, press STORE button, key in the telephone number and then the desired memory location button. Write down references to numbers stored against memory location buttons.

14.8 **PROGRAMMING CODES FOR CENTREX AND NETWORK SERVICES**

If you are using the a300 Headsetphone on an exchange line (not a PABX) and subscribe to network services provided by BT, or by another network provider, individual services may be programmed into the memory keys using the procedure outlined in 12.7., thus allowing you to use such services at the touch of a button. If you are a business user taking advantage of Centrex Service, these services may also be programmed into the one touch keys in this manner. However, it must be noted that the operating codes will differ for each service and in order to programme your telephone correctly a set of Network Service or Centrex codes should be obtained from your Network Operator. Programming codes for BT Network Services and many Centrex services, along with special memory inlay cards for ease of use are available from your supplier, or by contacting Pocket UK.

14.9 **CHANGING A NUMBER IN A MEMORY LOCATION**

If you wish to change a number in a memory location, simply follow the instructions for storing a number. Entering the new number will automatically erase the previous number.

14.10 **DIALLING NUMBERS FROM MEMORY**

To dial a number from memory, lift handset or press Speaker or Headset button, await dial tone and press button corresponding to memory location require ensuring that the correct memory 'shift' is selected.

Sometimes it may be necessary to combine the information from 2 memories or to combine memory dialling with manual dialling. In these cases, simply press the 2 memory buttons in sequence or press the desired memory button followed by manual dialling of the remainder of the number. These combinations are often carried out when alternative carriers are used.

14.11 **PAUSE FACILITY**

With some PABX's, it is necessary after dialling an outside line access digit (often 9) to wait for new dial tone before dialling the outside number. If the PAUSE button is pressed after the access digit has been dialled, the number may be dialled immediately without waiting for new dial tone as the telephone will introduce the required pause in the dialling sequence. In some cases it may be necessary to introduce a second pause, but do not enter more than 2 pauses or unsatisfactory operation may result.

14.12

MIXED DEAL MODE OPERATION STORING MIXED DIAL MODE NUMBERS

If you are connected to an exchange requiring PULSE dialling and you wish to route your calls via an alternative carrier (if available), it is necessary to dial an ACCESS code in PULSE mode followed by a pause and then an AUTHORISATION code in TONE mode. Since the telephone numbers of all calls to be re-routed via the alternative carrier will have to be preceded by the same access and authorisation codes, it is convenient to store them in a memory location.

For example, if your access code is 123 and your authorisation code is 4567890 and you wish to store the combined codes in memory location M1, you would proceed as follows:-

1. Seize the line in any mode.
2. Press STORE button once.
3. Key in 123
4. Press TONE button (this changes the dialling mode to tone)
5. Press PAUSE button to introduce a pause, Note that it may be necessary to introduce a second pause but do not enter more than 2 or incorrect operation may result.
6. Key in 4567890
7. Press M1 button
8. Release the line.

During the storing process, the number will be displayed in the LCD.



To dial a number via the alternative carrier, lift handset or press Speaker button, await dial tone, press M1 button and then dial the telephone number you are calling. Alternatively, press the M1 button followed by another memory button if the called number is stored in a memory location.

14.13

RECALL BUTTON

This is generally only used when the telephone is connected to a PABX (Private Automatic Branch Exchange) and gives access to features provided by that exchange. However, RECALL is becoming a feature on the new digital exchanges to give access to new services such as some of BT's Network Services.

For full information on the use of the RECALL button, please consult your PABX instructions or your Network Operator providing the services.

For setting the correct RECALL mode, please refer to section under 'INSTALLATION'.

14.14 AUTO CALL TIMER

If no key is pressed after dialling is finished, the Display will show the call timer after 6 seconds. The Call Timer will automatically indicate elapsed time during a call up to 59 minutes and 59 seconds.

To stop the call timer either “hang up” (or terminate handsfree or headset operation). The display will revert to current time.

14.15 * AND # BUTTONS

These are used with the new services provided by digital exchanges as well as accessing features on some PABX's. They have no dialling function in pulse dialling mode.

14.16 HANDSET MUTE BUTTON

When using the a300 Headsetphone in handset mode (not other modes), whilst the handset mute button is depressed the other party will not hear the conversation. If specified the a300 Headsetphone can be supplied with this button as 'push to talk', and in this instance the telephone will be clearly marked as such.

NB. The handset mute button is inoperable when the a300 Headsetphone is in handsfree or headset mode, and therefore all speech when in these modes will be transmitted normally.

14.17 BASE UNIT LATCHABLE MUTE

Pressing the MUTE button during a call will deactivate speech transmission. When mute is activated, its LED indicator will light up. Press the mute button again to deactivate the mute function.

14.18 SAVE FUNCTION

The SAVE button is used to store a dialled number, it may store up to 32 digits. To store a number press SAVE after the number had been dialled. You can also store a number had been dialled. You can also store a number into the SAVE button in the same way as storing a number into the memory location.

15. OPERATING PROCEDURE FOR PBX CONNECTION

The a300 Headsetphone is suitable for connection to a PABX which returns secondary proceed indication.

15.1 PBX RECALL

When connected to a PBX, the telephone will send a Recall Signal to the exchange when the RECALL button is pressed. This a300 Headsetphone provides either TIMED LINE BREAK RECALL or EARTH RECALL. Consult your PBX supplier or maintainer to ascertain which is compatible with your PBX. Having established which you require select either ELR (Earth Recall) or TBR (Timed Line Break Recall) using the ELR/TBR switch.

NB. Like the mute key the Recall key is a 'hard switches' not a 'soft press' key. This means that it will only depress slightly, and will remain depressed until released.

15.2 PABX PAUSE FACILITY

On PABX systems which provide secondary proceed indication you must wait for the secondary proceed dial tone after dialling the initial access digit(s), normally 9 for an outside line. For correct operation of the Memory facilities it is therefore necessary to store a Pause after the access digit to ensure correct dialling. Pressing the LNR key automatically inserts a 3.6 second pause in the dialling sequence.

NB: Do not enter more than 3 consecutive pauses. Failure to comply with this may result in unsatisfactory operation and will invalidate the approval.

15.3 MESSAGE WAITING OPERATION

On 4 wire systems set the switch to 2/5 to enable message waiting on compatible systems. For 6 wire systems set the switches to 1/6. Only one message waiting telephone may be connected to an extension. If more than one message waiting telephone is connected to a line, the system may interpret this as an off hook condition.

15.4 GENERAL USE

It must be noted that there is no guarantee of correct working of this telephone in all circumstances when connected to a PBX. Any difficulties should be referred to the telephone supplier.

This telephone is approved for connection to most PBX's. The supplier of this telephone should be consulted for an up to date list of PBX's with which this telephone is compatible.

16. IN CASE OF DIFFICULTY

In the event of the telephone failing to operate properly, please carry out the following:

- Check that the DIAL MODE SELECTOR and RECALL MODE SELECTOR switches are set to the correct positions for your telephone exchange. If set correctly disconnect the telephone plug from the telephone socket, lift the handset from the cradle and remove the batteries from the battery compartment. Wait for 5 minutes, refill the batteries, reset the clock and re-connect the telephone.

NOTE: If BT engineers are called out unnecessarily and the line is not at fault, a charge will be made. If difficulties are still experienced, please contact your supplier.

17. Care of your a300 Headsetphone

You have invested in a quality product and simple care and cleaning will keep it in good condition. The plastic parts and cards should be wiped with a cloth dampened with clean water.

DO NOT use spray polishes as these can affect the internal circuits.

DO NOT use abrasive cleaners as these will dull the high gloss finish.

DO NOT let the coiled cord become knotted or twisted.

Do not expose the unit to high temperatures by sitting near radiators, etc. Keep the unit dry and do not install or operate in outdoor conditions.

The handset and base should be cleaned with a soft cloth. Do not apply polishes or strong cleaning agents as these could damage the mouldings.



Distributed by:
Alphacom®
Incom House, Waterside
Trafford Park
Manchester, M17 1WD

Tel: 0161 935 1000
Fax: 0161 935 1015

www.alphacomtelecoms.co.uk
email: sales@alphacomtelecoms.co.uk



All Alphacom telephones are
manufactured to comply with
CE standards