



**Procedure & User
Programming Manual
For All Digital Controls**

Acura Spa Systems Inc.

2954 Rubidoux Blvd.

Riverside, CA 92509

Phone: (951) 684-6667 • Fax: (951) 684-6677

www.acuraspa.com

Rev. May.02.2007

TABLE OF CONTENTS

1	SAFETY INSTRUCTIONS	1
1-A	WARNING	1
1-B	RISK OF CHILD DROWNING	1
1-C	TO REDUCE THE RISK OF INJURY TO PEOPLE.....	1
2	INSTALLATION INSTRUCTIONS	4
2-A	ELECTRICAL INSTRUCTIONS.....	4
2-B	INSTALLATION OF PERMANENTLY INSTALLED UNITS	4
2-B1	General	4
2-B2	Wiring to Control Box – 240V, 4-Wire System	4
2-C	INSTALLATION OF CORD AND PLUG CONNECTED UNITS	4
2-D	BONDING.....	5
2-E	INSTALLATION OF POWER CORD	5
3	OPERATING INSTRUCTIONS FOR POWERSTATION SERIES	6
3-A	WARNING	6
3-B	G.F.C.I. (Optional)	6
3-C	Freeze Protection Operation	7
3-D	Seven Day Time Clock Operation	7
3-E	Twenty Four Hour Time Clock Operation	7
3-F	SPA Side Control (Optional)	8
3-F-1	Jet Air Button (Optional).....	8
3-F-2	Blower Air Button (Optional).....	8
3-F-3	Light Air Button (Optional).....	8
3-F-4	Booster Pump Air Button (Optional)	8
3-F-5	Gentle Pump Air Button (Optional).....	8
4	OPERATING INSTRUCTIONS FOR POWERQUIP SERIES	9
4-A	WARNING	9
4-B	G.F.C.I. (Optional)	9
4-C	Freeze Protection Operation	10
4-D	Seven Day Time Clock Operation	10
4-E	Twenty Four Hour Time Clock Operation	10
4-F	SPA Side Control (Optional)	11
4-F-1	Jet Air Button (Optional).....	11
4-F-2	Blower Air Button (Optional).....	11
4-F-3	Light Air Button (Optional).....	11
4-F-4	Booster Pump Air Button (Optional)	11
4-F-5	Gentle Pump Air Button (Optional).....	11
5	OPERATING INSTRUCTIONS FOR POWER SOURCE SERIES	12
5-A	WARNING	12
5-B	G.F.C.I. (Optional)	12

5-C	Freeze Protection Operation	13
5-D	Seven Day Time Clock Operation	13
5-E	Twenty Four Hour Time Clock Operation	13
5-F	SPA Side Control (Optional)	14
5-F-1	Jet Air Button (Optional).....	14
5-F-2	Blower Air Button (Optional).....	14
5-F-3	Light Air Button (Optional).....	14
5-F-4	Booster Pump Air Button (Optional)	14
5-F-5	Gentle Pump Air Button (Optional).....	14
6	OPERATING INSTRUCTIONS FOR HOTLINE MECHANICAL SERIES	15
6-A	WARNING	15
6-B	G.F.C.I. (Optional)	15
6-C	Freeze Protection Operation	16
6-D	Seven Day Time Clock Operation	16
6-E	Twenty Four Hour Time Clock Operation	16
6-F	SPA Side Control (Optional)	17
6-F-1	Jet Air Button (Optional).....	17
6-F-2	Blower Air Button (Optional).....	17
6-F-3	Light Air Button (Optional).....	17
6-F-4	Booster Pump Air Button (Optional)	17
6-F-5	Gentle Pump Air Button (Optional).....	17
7	OPERATING INSTRUCTIONS FOR HOTLINE MECHANICAL EXT. SERIES	18
7-A	WARNING	18
7-B	G.F.C.I. (Optional)	18
7-C	Freeze Protection Operation	19
7-D	Seven Day Time Clock Operation	19
7-E	Twenty Four Hour Time Clock Operation	19
7-F	SPA Side Control (Optional)	20
7-F-1	Jet Air Button (Optional).....	20
7-F-2	Blower Air Button (Optional).....	20
7-F-3	Light Air Button (Optional).....	20
7-F-4	Booster Pump Air Button (Optional)	20
7-F-5	Gentle Pump Air Button (Optional).....	20
8	DIGITAL INTRODUCTION.....	22
9	IN A HURRY.....	23
9-A	Setting the Temperature	23
9-B	The SET key	23
10	TIME OF DAY TOD	24
10-A	Setting TOD.....	24
11	THE CONTROL PANEL	25

12	DEVICE CONTROL PANEL	26
12-A	Primary Water Pump	26
12-B	Air Blower	26
12-C	Auxiliary Pump(s).....	26
12-D	Spa Light.....	26
12-E	Summary of Device Functions.....	27
13	STATUS CONTROL GROUP	28
13-A	The Temp Key	28
13-B	The Time Key	28
13-C	The Set Key.....	29
14	PROGRAMMING THE PM-3002 & HL2000	30
14-A	Parameter Programming.....	30
14-B	Programming Example	31
15	PARAMETER MENU LIST	32
16	PROGRAMMING SYSTEM OPTIONS.....	35
16-A	User Options.....	36
16-B	Protected Options	37
16-C	Diagnostic Values.....	38
16-D	Megatrol™ Indicator Lights	39
17	ERROR MESSAGES.....	41
17-A	CoLD.....	41
17-B	OH.....	41
17-C	HLEr	41
17-D	SEoP	41
17-E	SESH.....	42
17-F	PSoC, PSoL, PSoH.....	42
17-G	CboH.....	42
17-H	ToE.....	42
18	ELECTRICAL CONNECTION INSTRUCTIONS	43
19	BRANCH CIRCUIT BREAKER REQUIREMENTS	44
19-A	Terminal Block Electrical Connections.....	45
20	WARRANTY	46

(THIS PAGE INTENTIONALLY LEFT BLANK)

SAFETY INSTRUCTIONS

READ AND FOLLOW ALL INSTRUCTIONS!

1-A WARNING

Before operating your spa, do the following:

1. Turn Heater OFF.
2. Fill Spa with water. Water level should be halfway up the skimmer opening.
3. Make sure that all the valves are open.
4. Release all air from filter and heater chamber (see your filter's manual).
5. Turn jets on high for a few minutes.

NOTE: FAILURE TO FOLLOW THESE STEPS BEFORE OPERATING THE SPA SYSTEM MAY CAUSE A DRY FIRE AND WILL VOID YOUR WARRANTY.

1-B RISK OF CHILD DROWNING

DANGER!

Extreme caution must be exercised to prevent unsupervised access by children. To avoid accidents, ensure that children cannot use a spa or hot tub unless they are closely supervised at all times.

1-C TO REDUCE THE RISK OF INJURY TO PEOPLE

DANGER!

1. Do not remove suction fitting.
2. **RISK OF ELECTRICAL SHOCK:** Install at least 5 feet (1.5 meters) from all metal surfaces. Do not permit any electrical appliances, such as radio, television, telephone, lights, etc. within 5 feet (1.5 meters) of a spa or hot tub.
3. The water in a spa or hot tub should never exceed 104°F (40°C). Water temperature between 100°F (38°C) and 104°F (40°C) is considered safe for a healthy adult. Lower water temperatures are recommended for extended use, exceeding 10 or 15 minutes; and for young children. Since excessive water temperature has a high potential for causing fetal damage during pregnancy, pregnant or even possibly pregnant women should limit spa and hot tub use and its water temperature to 100°F (38°C). Consult your physician for further restrictions.

4. **RISK OF ACCIDENTAL DROWNING:** The use of alcoholic beverages, drugs, or medications before or during spa use may lead to unconsciousness with the possibility of drowning and could be fatal.
5. **RISK OF ACCIDENTAL DROWNING DUE TO HYPOTHERMIA:** If spa water temperature falls below 98.6°F (37°C), hypothermia may result. Hypothermia is defined as very low body temperature and is caused by loss of body heat after prolonged immersion in cold water. Its symptoms are: blueness of skin color, extreme fatigue, slowing of heartbeat, and lowering of blood pressure. Hypothermia can cause coma, permanent brain damage, and possibly death.
6. **REGULATING TEMPERATURE:** Temp. button on SoftTouch panel.
 - a. Always check water temperature with an accurate thermometer.
 - b. Prolonged immersion in hot water may induce hyperthermia. This occurs when the internal temperature of the body reaches a level of several degrees above the normal body temperature of 98.6°F (37°C). Its symptoms are: dizziness, fainting, drowsiness, lethargy, and an increase in the internal temperature of the body. The effects of hyperthermia include: unawareness of impending hazard, failure to perceive heat, failure to recognize the need to exit the spa, physical inability to exit the spa, fetal damage for pregnant women, and unconsciousness resulting in a danger of drowning.

WARNING: The use of alcohol, drugs, or medications can greatly increase the risk of fatal hyperthermia in hot tubs and spas.

7. **TO REDUCE THE RISK OF ELECTRICAL SHOCK:** Replace damaged or frayed cords immediately (for cord and plug connected units only).
8. Connect only to a ground type receptacle (for cord and plug connected units only).
9. Do not bury cord (for cord and plug connected units only).
10. This equipment is provided with a ground fault circuit interrupter on the equipment pack within the controller door. Before each use of your spa, with the unit connected to the power, push the test button. A trip indicator should appear. Push the reset button. The trip indicator should disappear. If the interrupter fails to operate in this manner there is a ground current flowing, indicating the possibility of an electrical short. Disconnect the power from the unit until the source of the breakdown has been identified and corrected.
11. Provide drainage of compartment for electrical components.
12. Before entering a spa or hot tub, measure the water temperature with an accurate thermometer. The tolerance of water temperature regulatory devices may vary as much as $\pm 1^{\circ}\text{F}$ ($\pm 0.5^{\circ}\text{C}$).
13. Persons suffering from obesity or with a medical history of heart disease, low or high blood pressure, circulatory system problems, or diabetes should consult a physician before using a spa or hot tub.
14. Persons using medication should consult a physician before using a spa or hot tub. Some medications may induce drowsiness; while other medications may affect heart rate, blood pressure, and circulation.
15. The electrical supply for this product must include a suitably rated switch or circuit breaker to open all ungrounded supply conductors to comply with

Section 422-20 of National Electric Code ANSI/NFPA 70-1987; a disconnecting means must be readily accessible to the tub occupant, but installed at least 5 feet (1.5 meters) from the tub.

16. **PRESSURE WIRE CONNECTOR** (for all units): A pressure wire connector is provided in the control box inside the unit to permit connection of a minimum No. 8 AWG (8.4 mm²) solid copper bonding conductor between this point and any metal equipment, metal enclosures of electrical equipment, metal water pipe, or conduit within 5 feet (1.5 meters) of the unit as needed to comply with local requirements.
17. **FOR UNITS WITH G.F.C.I.** (Ground Fault Circuit Interrupter): The G.F.C.I. is located on the right hand side of the upper front panel of the Powertronics control box. It must be tested before each use.
18. **FOR UNITS WITH GAS HEATERS:** Do not install the gas heaters indoors.

SAVE THESE INSTRUCTIONS!

2 INSTALLATION INSTRUCTIONS

2-A ELECTRICAL INSTALLATION

All electrical installations must be done by a licensed electrician and must be wired per the National Electric Code as well as all local codes and regulations.

2-B INSTALLATION OF PERMANENTLY INSTALLED UNITS

2-B1 GENERAL

1. The electrical supply for this unit must include a suitably rated switch or circuit breaker to open all ungrounded supply conductors to comply with Section 422-20 of National Electric Code ANSI/NFPA 70-1987; a disconnecting means must be readily accessible to the hot tub occupant, but installed at least 5 feet (1.5 meters) from the hot tub water.
2. Remove the bottom front panel of the control box; the terminal block is located approximately 3.5" from the incoming power cord.
3. User copper conductors only.
4. If a Ground Fault Circuit Interrupter (G.F.C.I.) is not provided with the unit, an electrician must install a G.F.C.I. breaker as of January 1, 1994 as per the National Electric Code.

2-B2 Wiring to Control Box – 240V, 4-Wire System

1. Ground to power terminal block is marked "G".
2. Neutral to power terminal block is marked "N".
3. Hot to power terminal block is marked "L2".
4. Hot to power terminal block is marked "L1".

2-C INSTALLATION OF PERMANENTLY INSTALLED UNITS

1. Connect to a grounded, grounding type receptacle only. Never connect the spa to an extension cord.
2. Do not bury cord.
3. Replace damaged cord immediately.

2-D BONDING

The enclosure of each electrical component and all other metal that could be energized and is accessible to the person servicing the equipment shall be bonded to the ground conductor bar. This includes the following:

1. The pump motor bonding lug.
2. The heater bonding lug located on the manifold (heater enclosure).
3. The blower bonding lug.
4. Any other non-energized metal with 5 feet (1.5 meters) of the spa or hot tub.
5. The bonding lug secured on the underside of the same metallic plate as the grounding conductor bar in the control box.

2-E OPERATING INSTRUCTIONS

Read all of the operating instructions BEFORE operating the systems.

3 OPERATING INSTRUCTIONS FOR POWER STATION SERIES



3-A WARNING

Always do the following BEFORE operating your spa:

1. Turn heater OFF.
2. Fill spa water. Water level should be halfway up the skimmer opening.
3. Make sure all valves are open.
4. Release all air from heater chamber (use air bleeder valve located on discharge side of the heater chamber provided in spa plumbing).
5. Turn jets on high for 5 minutes and make sure the pump is not surging.
6. Failure to follow these steps before operating the heater may cause a dry fire (burnout the heater) and will void your warranty.

3-B G.F.C.I. (Optional)

If not provided with the equipment pack, a Ground Fault Circuit Interrupter (G.F.C.I.) breaker must be installed.

3-B1 The G.F.C.I. is located on the upper front panel of the control box.

3-B2 Press red button on G.F.C.I. "IN" and close spa door.

3-B3 Push buttons located on spa side control and the system must function properly, otherwise contact your local dealer or refer to troubleshooting manual.

- 3-B4** G.F.C.I. must be tested monthly (preferably before each spa use) by pushing black button "IN", the red button must pop "OUT" opening all electrical circuits. By pressing red button "IN", red button must stay "IN", otherwise contact your local dealer or refer to troubleshooting manual.

3-C FREEZE PROTECTING CIRCUIT

- 3-C1** For units with 7-day time clock (RED), a freeze protection switch is located on the left side of the 7-day time clock to override the 7-day time clock and let slow speed pump and heater be controlled by the thermostat.

NOTE: If filtration is needed, pull time clock pins "OUT" allows low speed pump to run during the selected time interval (refer to paragraph 3-D).

- 3-C2** For units with 24-hour time clock (BLUE), a freeze protection switch is provided to override the 24-hour time clock and let low speed pump operate continuously.

3-D SEVEN DAY TIME CLOCK OPERATION

- 3-D1** The 7-day time clock is set to control the heater as well as low speed pump simultaneously. The 7-day time clock provides setting each day of the week or operation may be discontinued on any day of the week. Each tripper will turn heater "on" for a minimum of three hours. The 7-day time clock has 56 permanently attached trippers that can easily be set by hand without any tools.

- 3-D2** Toggle switch, located on the left side of the 7-day clock must be in the "up" position (Timer) for the time clock to operate.

- 3-D3** Turn temperature control to maximum.

- 3-D4** Select the desired time on 7-day time clock to start operating low speed pump and heater.

3-E TWENTY FOUR HOUR TIME CLOCK OPERATION

- 3-E1** The 24-hour time clock is set to control low speed pump and ozonator.

- 3-E2** The 24-hour time clock has 48 permanently attached trippers that can easily be set by hand without any tools. Each tripper would turn low speed pump "ON" for thirty minutes.

3-E3 Toggle switch located on left side of 24-hour time clock must be in "up" position (Timer) for the time clock to operate.

3-F SPA SIDE CONTROL (OPTIONAL)

Spa side control is located on spa shell could be provided with a temperature controller (thermostat).

3-F1 Jet Air Button: located on spa side control marked "jets". Push jet button once, high speed pump comes "on" (make sure pump is not surging); turn thermostat knob clockwise to maximum; heater light should come "on" (except for 220V – 30A and 120V – 20A), with thermostat knob to maximum, push jet button once more, low speed pump will come "on" along with the ozonator (make sure the rocker switch is in proper position).

3-F2 Blower Air Button (optional): located on spa side control, maybe marked "warm air". Push air button once to turn blower "on". Push air button once more to turn blower "off".

3-F3 Light Air Button (optional): located on spa side control, marked spa light. Push air button once to turn spa light "on". Push air button once more to turn spa light "off".

3-F4 Booster Pump Air Button (optional): located on spa side control, marked "Booster Hi" or "Jet 2". Push air button once, high speed pump will come "on". Push air button once more to turn high speed pump "off".

3-F5 Gentle Pump Air Button (optional): located on spa side control, marked "Gentle Pump". Push air button once, low speed pump will come "on" (only if Booster Hi is "off"). Push air button once more to turn low speed pump "off".

4 OPERATING INSTRUCTIONS FOR POWERQUIP SERIES



4-A WARNING

Always do the following BEFORE operating your spa:

1. Turn heater OFF.
2. Fill spa water. Water level should be halfway up the skimmer opening.
3. Make sure all valves are open.
4. Release all air from heater chamber (use air bleeder valve located on discharge side of the heater chamber provided in spa plumbing).
5. Turn jets on high for 5 minutes and make sure the pump is not surging.
6. **Failure to follow these steps before operating the heater may cause a dry fire (burnout the heater) and will void your warranty.**

4-B G.F.C.I. (Optional)

If not provided with the equipment pack, a Ground Fault Circuit Interrupter (G.F.C.I.) breaker must be installed.

4-B1 The G.F.C.I. is located on the upper front panel of the control box.

4-B2 Press red button on G.F.C.I. "IN" and close spa door.

4-B3 Push buttons located on spa side control and the system must function properly, otherwise contact your local dealer or refer to troubleshooting manual.

4-B4 G.F.C.I. must be tested monthly (preferably before each spa use) by pushing black button "IN", the red button must pop "OUT" opening all electrical circuits. By pressing red button "IN", red button must stay "IN", otherwise contact your local dealer or refer to troubleshooting manual.

4-C FREEZE PROTECTING CIRCUIT

4-C1 For units with 7-day time clock (RED), a freeze protection switch is located on the left side of the 7-day time clock to override the 7-day time clock and let slow speed pump and heater be controlled by the thermostat.

4-D SEVEN DAY TIME CLOCK OPERATION

4-D1 The 7-day time clock is set to control the heater as well as low speed pump simultaneously. The 7-day time clock provides setting each day of the week or operation may be discontinued on any day of the week. Each tripper will turn heater "on" for a minimum of three hours. The 7-day time clock has 56 permanently attached trippers that can easily be set by hand without any tools.

4-D2 Toggle switch, located on the left side of the 7-day clock must be in the "up" position (Timer) for the time clock to operate.

4-D3 Turn temperature control to maximum.

4-D4 Select the desired time on 7-day time clock to start operating low speed pump and heater.

4-E TWENTY FOUR HOUR TIME CLOCK OPERATION

4-E1 The 24-hour time clock is set to control low speed pump and ozonator.

4-E2 The 24-hour time clock has 48 permanently attached trippers that can easily be set by hand without any tools. Each tripper would turn low speed pump "ON" for thirty minutes.

4-E3 Toggle switch located on left side of 24-hour time clock must be in "up" position (Timer) for the time clock to operate.

4-F SPA SIDE CONTROL (OPTIONAL)

Spa side control is located on spa shell could be provided with a temperature controller (thermostat).

4-F1 Jet Air Button: located on spa side control marked "jets". Push jet button once, high speed pump comes "on" (make sure pump is not surging); turn thermostat knob clockwise to maximum; heater light should come "on" (except for 220V – 30A and 120V – 20A), with thermostat knob to maximum, push jet button once more, low speed pump will come "on" along with the ozonator (make sure the rocker switch is in proper position).

4-F2 Blower Air Button (optional): located on spa side control, maybe marked "warm air". Push air button once to turn blower "on". Push air button once more to turn blower "off".

4-F3 Light Air Button (optional): located on spa side control, marked spa light. Push air button once to turn spa light "on". Push air button once more to turn spa light "off".

4-F4 Booster Pump Air Button (optional): located on spa side control, marked "Booster Hi" or "Jet 2". Push air button once, high speed pump will come "on". Push air button once more to turn high speed pump "off".

4-F5 Gentle Pump Air Button (optional): located on spa side control, marked "Gentle Pump". Push air button once, low speed pump will come "on" (only if Booster Hi is "off"). Push air button once more to turn low speed pump "off".

5 OPERATING INSTRUCTIONS FOR POWER SOURCE AND MEGATROL™ SERIES



5-A WARNING

Always do the following BEFORE operating your spa:

1. Turn heater OFF.
2. Fill spa water. Water level should be halfway up the skimmer opening.
3. Make sure all valves are open.
4. Release all air from heater chamber (use air bleeder valve located on discharge side of the heater chamber provided in spa plumbing).
5. Turn jets on high for 5 minutes and make sure the pump is not surging.
6. Failure to follow these steps before operating the heater may cause a dry fire (burnout the heater) and will void your warranty.

5-B G.F.C.I. (Optional)

If not provided with the equipment pack, a Ground Fault Circuit Interrupter (G.F.C.I.) breaker must be installed.

5-B1 The G.F.C.I. is located on the upper front panel of the control box.

5-B2 Press red button on G.F.C.I. "IN" and close spa door.

5-B3 Push buttons located on spa side control and the system must function properly, otherwise contact your local dealer or refer to troubleshooting manual.

5-B4 G.F.C.I. must be tested monthly (preferably before each spa use) by pushing black button "IN", the red button must pop "OUT" opening all electrical circuits.

By pressing red button "IN", red button must stay "IN", otherwise contact your local dealer or refer to troubleshooting manual.

5-C FREEZE PROTECTING CIRCUIT

5-C1 For units with 7-day time clock (RED), a freeze protection switch is located on the left side of the 7-day time clock to override the 7-day time clock and let slow speed pump and heater be controlled by the thermostat.

5-D SEVEN DAY TIME CLOCK OPERATION

5-D1 The 7-day time clock is set to control the heater as well as low speed pump simultaneously. The 7-day time clock provides setting each day of the week or operation may be discontinued on any day of the week. Each tripper will turn heater "on" for a minimum of three hours. The 7-day time clock has 56 permanently attached trippers that can easily be set by hand without any tools.

5-D2 Toggle switch, located on the left side of the 7-day clock must be in the "up" position (Timer) for the time clock to operate.

5-D3 Turn temperature control to maximum.

5-D4 Select the desired time on 7-day time clock to start operating low speed pump and heater.

5-E TWENTY FOUR HOUR TIME CLOCK OPERATION

5-E1 The 25-hour time clock is set to control low speed pump and ozonator.

5-E2 The 25-hour time clock has 48 permanently attached trippers that can easily be set by hand without any tools. Each tripper would turn low speed pump "ON" for thirty minutes.

5-E3 Toggle switch located on left side of 25-hour time clock must be in "up" position (Timer) for the time clock to operate.

5-F SPA SIDE CONTROL (OPTIONAL)

Spa side control is located on spa shell could be provided with a temperature controller (thermostat).

- 5-F1 **Jet Air Button:** located on spa side control marked "jets". Push jet button once, high speed pump comes "on" (make sure pump is not surging); turn thermostat knob clockwise to maximum; heater light should come "on" (except for 220V – 30A and 120V – 20A), with thermostat knob to maximum, push jet button once more, low speed pump will come "on" along with the ozonator (make sure the rocker switch is in proper position).
- 5-F2 **Blower Air Button (optional):** located on spa side control, maybe marked "warm air". Push air button once to turn blower "on". Push air button once more to turn blower "off".
- 5-F3 **Light Air Button (optional):** located on spa side control, marked spa light. Push air button once to turn spa light "on". Push air button once more to turn spa light "off".
- 5-F4 **Booster Pump Air Button (optional):** located on spa side control, marked "Booster Hi" or "Jet 2". Push air button once, high speed pump will come "on". Push air button once more to turn high speed pump "off".
- 5-F5 **Gentle Pump Air Button (optional):** located on spa side control, marked "Gentle Pump". Push air button once, low speed pump will come "on" (only if Booster Hi is "off"). Push air button once more to turn low speed pump "off".

6 OPERATING INSTRUCTIONS FOR HOTLINE MECH. SERIES

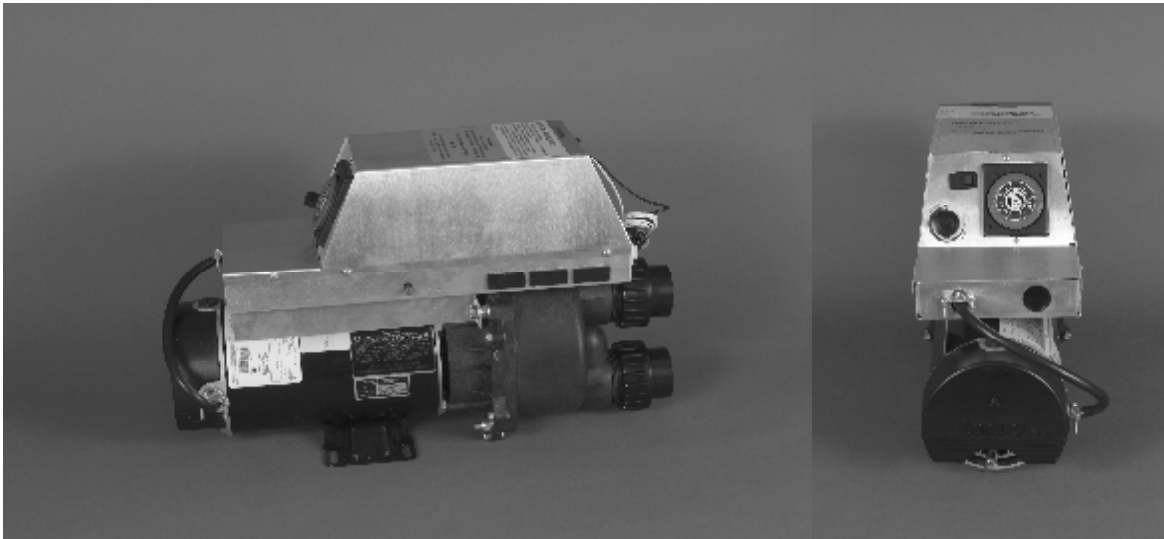

6-A WARNING

Always do the following BEFORE operating your spa:

1. Turn heater OFF.
2. Fill spa water. Water level should be halfway up the skimmer opening.
3. Make sure all valves are open.
4. Release all air from heater chamber (use air bleeder valve located on discharge side of the heater chamber provided in spa plumbing).
5. Turn jets on high for 5 minutes and make sure the pump is not surging.
6. **Failure to follow these steps before operating the heater may cause a dry fire (burnout the heater) and will void your warranty.**

6-B G.F.C.I. (Optional)

If not provided with the equipment pack, a Ground Fault Circuit Interrupter (G.F.C.I.) breaker must be installed.

6-B1 The G.F.C.I. is located on the upper front panel of the control box.

6-B2 Press red button on G.F.C.I. "IN" and close spa door.

6-B3 Push buttons located on spa side control and the system must function properly, otherwise contact your local dealer or refer to troubleshooting manual.

6-B4 G.F.C.I. must be tested monthly (preferably before each spa use) by pushing black button "IN", the red button must pop "OUT" opening all electrical circuits.

By pressing red button "IN", red button must stay "IN", otherwise contact your local dealer or refer to troubleshooting manual.

6-C FREEZE PROTECTING CIRCUIT

6-C1 For units with 7-day time clock (RED), a freeze protection switch is located on the left side of the 7-day time clock to override the 7-day time clock and let slow speed pump and heater be controlled by the thermostat.

6-D SEVEN DAY TIME CLOCK OPERATION

6-D1 The 7-day time clock is set to control the heater as well as low speed pump simultaneously. The 7-day time clock provides setting each day of the week or operation may be discontinued on any day of the week. Each tripper will turn heater "on" for a minimum of three hours. The 7-day time clock has 56 permanently attached trippers that can easily be set by hand without any tools.

6-D2 Toggle switch, located on the left side of the 7-day clock must be in the "up" position (Timer) for the time clock to operate.

6-D3 Turn temperature control to maximum.

6-D4 Select the desired time on 7-day time clock to start operating low speed pump and heater.

6-E TWENTY FOUR HOUR TIME CLOCK OPERATION

6-E1 The 26-hour time clock is set to control low speed pump and ozonator.

6-E2 The 26-hour time clock has 48 permanently attached trippers that can easily be set by hand without any tools. Each tripper would turn low speed pump "ON" for thirty minutes.

6-E3 Toggle switch located on left side of 26-hour time clock must be in "up" position (Timer) for the time clock to operate.

6-F SPA SIDE CONTROL (OPTIONAL)

Spa side control is located on spa shell could be provided with a temperature controller (thermostat).

- 6-F1 Jet Air Button:** located on spa side control marked "jets". Push jet button once, high speed pump comes "on" (make sure pump is not surging); turn thermostat knob clockwise to maximum; heater light should come "on" (except for 220V – 30A and 120V – 20A), with thermostat knob to maximum, push jet button once more, low speed pump will come "on" along with the ozonator (make sure the rocker switch is in proper position).
- 6-F2 Blower Air Button (optional):** located on spa side control, maybe marked "warm air". Push air button once to turn blower "on". Push air button once more to turn blower "off".
- 6-F3 Light Air Button (optional):** located on spa side control, marked spa light. Push air button once to turn spa light "on". Push air button once more to turn spa light "off".
- 6-F4 Booster Pump Air Button (optional):** located on spa side control, marked "Booster Hi" or "Jet 2". Push air button once, high speed pump will come "on". Push air button once more to turn high speed pump "off".
- 6-F5 Gentle Pump Air Button (optional):** located on spa side control, marked "Gentle Pump". Push air button once, low speed pump will come "on" (only if Booster Hi is "off"). Push air button once more to turn low speed pump "off".

7 OPERATING INSTRUCTIONS FOR HOTLINE MECH. EXT SERIES

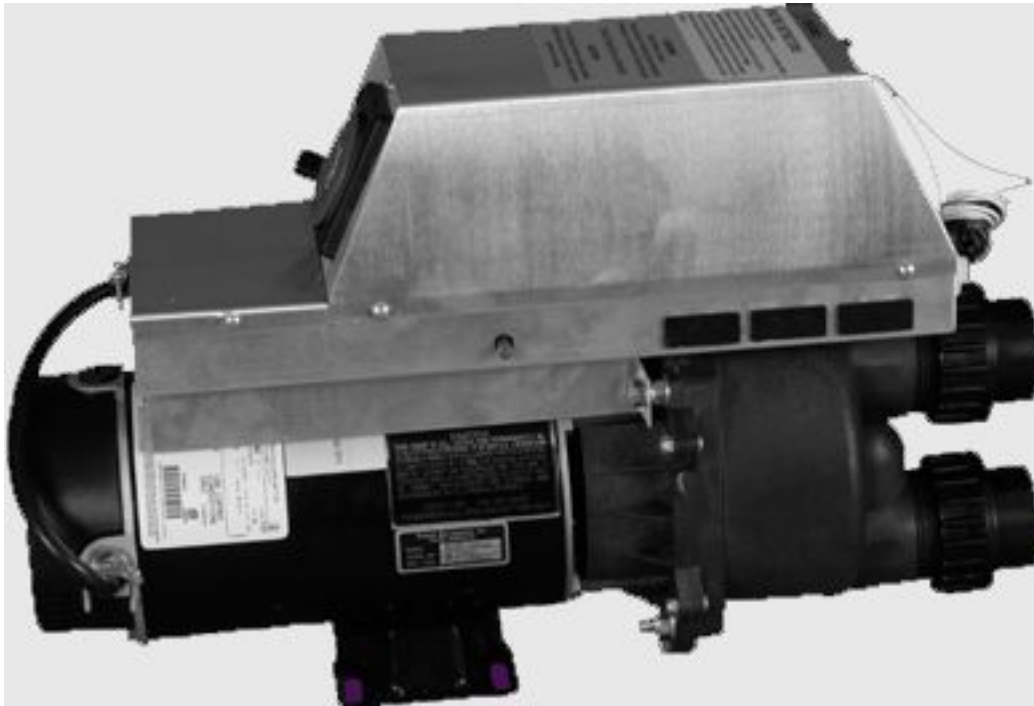

7-A WARNING

Always do the following BEFORE operating your spa:

1. Turn heater OFF.
2. Fill spa water. Water level should be halfway up the skimmer opening.
3. Make sure all valves are open.
4. Release all air from heater chamber (use air bleeder valve located on discharge side of the heater chamber provided in spa plumbing).
5. Turn jets on high for 5 minutes and make sure the pump is not surging.
6. **Failure to follow these steps before operating the heater may cause a dry fire (burnout the heater) and will void your warranty.**

7-B G.F.C.I. (Optional)

If not provided with the equipment pack, a Ground Fault Circuit Interrupter (G.F.C.I.) breaker must be installed.

7-B1 The G.F.C.I. is located on the upper front panel of the control box.

7-B2 Press red button on G.F.C.I. "IN" and close spa door.

7-B3 Push buttons located on spa side control and the system must function properly, otherwise contact your local dealer or refer to troubleshooting manual.

7-B4 G.F.C.I. must be tested monthly (preferably before each spa use) by pushing black button "IN", the red button must pop "OUT" opening all electrical circuits. By pressing red button "IN", red button must stay "IN", otherwise contact your local dealer or refer to troubleshooting manual.

7-C FREEZE PROTECTING CIRCUIT

7-C1 For units with 7-day time clock (RED), a freeze protection switch is located on the left side of the 7-day time clock to override the 7-day time clock and let slow speed pump and heater be controlled by the thermostat.

7-D SEVEN DAY TIME CLOCK OPERATION

7-D1 The 7-day time clock is set to control the heater as well as low speed pump simultaneously. The 7-day time clock provides setting each day of the week or operation may be discontinued on any day of the week. Each tripper will turn heater "on" for a minimum of three hours. The 7-day time clock has 56 permanently attached trippers that can easily be set by hand without any tools.

7-D2 Toggle switch, located on the left side of the 7-day clock must be in the "up" position (Timer) for the time clock to operate.

7-D3 Turn temperature control to maximum.

7-D4 Select the desired time on 7-day time clock to start operating low speed pump and heater.

7-E TWENTY FOUR HOUR TIME CLOCK OPERATION

7-E1 The 27-hour time clock is set to control low speed pump and ozonator.

7-E2 The 27-hour time clock has 48 permanently attached trippers that can easily be set by hand without any tools. Each tripper would turn low speed pump "ON" for thirty minutes.

7-E3 Toggle switch located on left side of 27-hour time clock must be in "up" position (Timer) for the time clock to operate.

7-F SPA SIDE CONTROL (OPTIONAL)

Spa side control is located on spa shell could be provided with a temperature controller (thermostat).

- 7-F1 **Jet Air Button:** located on spa side control marked "jets". Push jet button once, high speed pump comes "on" (make sure pump is not surging); turn thermostat knob clockwise to maximum; heater light should come "on" (except for 220V – 30A and 120V – 20A), with thermostat knob to maximum, push jet button once more, low speed pump will come "on" along with the ozonator (make sure the rocker switch is in proper position).
- 7-F2 **Blower Air Button (optional):** located on spa side control, maybe marked "warm air". Push air button once to turn blower "on". Push air button once more to turn blower "off".
- 7-F3 **Light Air Button (optional):** located on spa side control, marked spa light. Push air button once to turn spa light "on". Push air button once more to turn spa light "off".
- 7-F4 **Booster Pump Air Button (optional):** located on spa side control, marked "Booster Hi" or "Jet 2". Push air button once, high speed pump will come "on". Push air button once more to turn high speed pump "off".
- 7-F5 **Gentle Pump Air Button (optional):** located on spa side control, marked "Gentle Pump". Push air button once, low speed pump will come "on" (only if Booster Hi is "off"). Push air button once more to turn low speed pump "off".

THE NEXT SECTION ONLY APPLIES TO DIGITAL CONTROL SYSTEMS

MEGATROL™ POWER MASTER QUICK SET MINITROL TINYTROL & CHL



Megatrol™

**Applies only for Digital Controls:
Megatrol™, Power Master, Quick Set, Minitrol, Tinytrol & CHL**

8 INTRODUCTION

Thank you for buying a spa equipped with a digital spa control system from Acura Spa Systems, Inc. Many years of experience went into the design of this family of controls. You can be assured your spa control system is the most advanced; it is highly reliable and will serve you for many years to come.

The control system has been designed with you, the user, in mind. It is very easy to operate and requires a minimal effort on your part. You may use it just as it comes to you and without any programming. Yet you have the option of getting deeply involved in the inner workings of the control if you so choose. You can custom tailor it to fit your needs.

Please take the time to read at least the first section "IN A HURRY – READ THIS" portion of the manual before starting to use your spa for the first time. You can familiarize yourself with the rest of the manual at your leisure. This manual will also serve as a reference if you choose to modify the operation of your spa.

**SAVE THIS MANUAL.
Make it available for other spa users.**

You should also have a spa user's manual, which explains how to care for your spa. Please read and follow all instructions in your spa user's manual. Maintaining the proper levels of pH and the sanitizer will extend the life of your spa equipment. Improper chemical levels in the spa are sure to cause premature heater failure as well as failure of other components in the system. Failures caused by chemical imbalance are not covered by warranty.

9 IN A HURRY – READ THIS

For those who don't like to read manuals or would like to read the manual later, please read at least the following section.

Your control system comes to you programmed with a universal set of default settings. If you choose to keep these settings, then you only need to remember two things: how to set the spa temperature and to press the SET key whenever you are done using the spa.

Setting Temperature

- ◆ Press and hold the TEMP key for 2 seconds, then release all keys. The display will flash the current selected temperature.
- ◆ Using the TEMP and TIME keys (UP or DOWN arrows) scroll to the desired temperature.
- ◆ Press the SET key to lock in the new selection.

The SET Key

After using the spa, press the SET key to tell the microcontroller you are done using the spa. It will then take over the spa's management including the different filtration cycles, heat maintenance, economy modes and protection against freezing.

Upon entering this mode the FILTER light is turned on and a post use filtration cycle is executed – that is when the spa needs filtration the most. The default system setting includes a 3 hour economy mode; the pump will come on at most once every 3 hours to sample water temperature and heat if necessary. The controller remembers when you have used the spa and in anticipation of your next usage will perform a 3 hour Auto Filtration cycle before your next spa use.

Power Master 3002 and Hot Line 2000 are members of a family of intelligent spa control systems rich with features and can be extensively programmed to fit just about any need. The rest of this manual will explain the function of each of the keys on the control panel, how to change programmed settings and what each setting does. It will also explain all the error messages that you may encounter, and their significance and way to correct them.

10 TIME OF DAY (TOD)

The control system maintains a 12-hour AM/PM internal real time clock TOD (Time of Day). The clock is based on the line frequency. There is no battery backup and whenever the power is turned off, TOD is no longer correct. It defaults to 12:00 AM whenever the power is turned on.

Setting TOD is only necessary if you are going to program the filtration and silence cycles. If you use the factory default settings then you do not need to set the TOD.

If you set TOD the controller will display time the first 10 seconds of each minute. If TOD has not been set then it will not be displayed.

Setting TOD

1. Press and hold the TIME key for 2 seconds. Current TOD will be displayed with the hour portion flashing.
2. Release the TIME key.
3. Using the TEMP and TIME keys, scroll up and down to the desired hour. Notice the AM/PM led.
4. When the correct hour and AM/PM are displayed, press the SET key to lock in the new hour.
5. The display will now flash the minutes portion of current TOD.
6. Using TIME and TEMP scroll to the desired minutes.
7. When the correct minutes are displayed press the SET key to lock in the time of day (hour and minutes).

Note: TOD is the only parameter in your control system that is not preserved on power down. On power up it will default to 12:00 AM, all other parameters are restored to their last setting.

Every time the controller is powered up, the microprocessor automatically measures and determines the line frequency is 50 or 60 cycles in order to maintain the correct TOD.

11 THE CONTROL PANEL

The control panel is normally installed on the lip of the spa for easy and convenient access. Within the panel housing is a 4-digit LED display used to communicate to the user the spa temperature, TOD, elapsed user time, programming, status – diagnostic and error codes and messages. There are two (2) different panel sizes and they are interchangeable. The PM 3002 Series panel can have up to 7 keys and the HL 2000 Series panel will have at most 6 keys. These are membrane type switches which when depressed generate a signal that the microprocessor will interpret and act upon. The switches are labeled and have specific functions. They are divided into 2 groups:

Device Control Group: Pump(s), Air Blower, Spa Light keys.

Status Control Group: Up, Down, Set keys.

Note: If any of the keys is pressed and held closed for longer than 20 seconds, that key will be disabled and becomes non-functional. After releasing the key, it will be reactivated after 20 seconds. This is to prevent a collapsed or defective key from locking up the system.

12 DEVICE CONTROL GROUP

There are up to 4 device keys, JETS, AIR, AUX, & LIGHT. Your spa will have at least one water pump. Optionally your spa may have an air blower, a second and/or third pump and a spa light. It may not also have a mister or a fiber optic light setup. If your spa does not have a specific device please disregard the function of that device.

12-A Primary Water Pump

Each spa should have at least one primary water pump which is usually a dual speed pump. The low speed is used to filter the spa. Also while the spa is being heated or there is an error condition, the low speed circulates the water and you will not be able to turn it off.

The JETS key (switch) on the control panel is a 3 position switch: Low Pump, High Pump, Off. Each time the key is pressed, the next function is executed. If your primary pump is a single speed then only the high pump will be activated. Two (2) LED indicators, LO & HI inform you which speed is on.

Note: If your spa is equipped with a circulating pump, it will be used for filtration and heating instead of the low speed pump.

12-B Air Blower

If your spa is equipped with an air blower (bubbler), it is activated by the AIR key. This is an ON/OFF key. An LED will indicate when the air blower is on.

12-C Auxiliary Pump(s)

Your spa may be equipped with 1 or 2 more pumps. If you have a second pump, it could be a single speed or a dual speed.

If you have a third pump, then both the second and third pumps must be single speed. The function of the AUX key changes with the number and type of auxiliary pumps used. Please consult with the table on the following page for the proper sequence of activation.

12-D Spa Light

The LIGHT key can also be a multifunction key. In its simplest configuration, the LIGHT key is a simple on/off switch. It turns the spa light and the accessory, if one is attached, on/off together at the same time. Alternatively, the LIGHT key may be programmed as a 3 function key. Pressing it once will turn the spa light on. Pressing it a second time will turn on the attached accessory, while the light is still on. Press it a third time and both the spa light a accessory will go off.

Table 1 summarizes all the possible device key combinations. Please note that your spa may not necessarily have all these devices attached.

SUMMARY OF FUNCTIONS FOR EACH DEVICE					
Key	Device	1	2	3	4
	Single speed pump	ON	OFF		
JETS	Dual speed pump	LOW	HIGH	OFF	
	Dual speed with Circ pump	LOW	HIGH	OFF	
	Circ pump is independent				
AIR	Single speed air blower	ON	OFF		
	One single Speed pump	ON	OFF		
AUX	One dual speed pump	LOW	HIGH	OFF	
	Two Single speed pumps	P1	P1&P2	P2	ALL OFF
	Spa light	ON	OFF		
LITE	Spa Light & Accessory	Both	Both		
		ON	OFF		
	Spa Light & Accessory	Light	Both	Both	
	3 Function	ON	ON	OFF	

Table 1 - Device keys summary of functions

The four device keys, JETS, AIR, AUX and LITE are exclusive, when one is pressed, no other key may be pressed simultaneously. You must release the pressed key before you may press another key. Also these keys do not repeat.

If you press and hold a key for more than 20 seconds that key will be considered defective (collapsed) and will be deactivated and ignored by the system. When released, the key will stay inactive for 20 seconds before it is recognized and activated.

13 STATUS CONTROL GROUP

The keys in this group are used to communicate to the controller system settings and option selection(s). There are 3 keys in this group and 3 functions that are combinations of these keys:

Key Press	Function
TEMP (up arrow)	Prog Temp, + or Next
TIME (down arrow)	Prog TOD, - or Previous
SET key.	Select or Accept, Enter
SET & TEMP	Invert display
SET & TIME	Parameter programming
TEMP & TIME	System programming

Table 2 – Status Control Keys Summary

13-A The TEMP key, which is also the UP ARROW key, is a repeat key, if held down. Think of this key as "+ or next". Use it to:

- ◆ Press and hold for 2 seconds then release it to start desired temperature selection.
- ◆ During temperature setting press TEMP to increase selected temperature.
- ◆ When doing system programming, press TEMP to scroll to the next message.
- ◆ After message selection, the system displays the associated value, press TEMP to increase the value.

NOTE: When the display is inverted, you will be able to read the display from inside the spa. However, the keys will retain their functions and will not be inverted. The UP ARROW will still function as the UP ARROW even though when you look at it from within the spa it appears to be the DOWN ARROW. The same also applies to the rest of the keys.

13-B The TIME key, which is also the DOWN ARROW key, is also a repeat key. Think of it as "- or previous". Use it to:

- ◆ Press and hold for 2 seconds then release it to start setting the real time clock (TOD).
- ◆ During time setting press TIME to decrease the hours or minutes value that is being set.
- ◆ When doing system programming, press TIME to scroll to the previous message.
- ◆ After selecting a message, the system displays the associated value, press TIME to decrease the value.

13-C The SET key is equivalent to Select or Accept. It functions as an Enter key of a personal computer; it is the proverbial “hit any key to continue”. Press the Set key to:

- ◆ After using the spa, press the SET key to tell the controller to take over the management of the spa.
- ◆ During temperature setting, press the SET key to lock in a new selected temperature.
- ◆ During time of day programming, press the SET key to lock in the hour and the minutes.
- ◆ When a message is displayed during parameter programming, press SET to select that message.
- ◆ When a parameter value is displayed, press SET to accept the displayed value and return to message display.
- ◆ During option programming, press SET to toggle a parameter ON or OFF.
- ◆ When a “HLoH” error message is displayed, press the SET key to clear the error (if the cause has been corrected). Pressing the SET key, the user acknowledges that the cause of the hi limit error has been or will be corrected.

NOTE: UP is synonymous with TEMP and DOWN is the same key as TIME. These are used interchangeably and mean the same thing. Scrolling means pushing either the UP or the DOWN key to go to the next or previous item or value.

14 PROGRAMMING THE PM-3002 & HL2000

14-A Parameter Programming is a means by which the spa owner/user can change the various timing elements and calibrate temperature. The process is simple and intuitive. Only 3 keys are used; UP, DOWN, and SET. To program one or more parameters, follow this outlined procedure:

1. Press the SET and DOWN keys together. The first message in the menu, FP1 will be displayed.
2. Use the UP & DOWN keys to scroll through the messages in the menu.
3. Press the SET key to display the current value associated with the current message.
4. Use the UP or DOWN keys to increase or decrease the value.
5. Press SET to lock in the new value and return to the menu.
6. If another item needs programming, go to number 2 above.
7. To save changes, scroll to message SEND and press SET.
8. To discard changes and restore previous values, scroll to message CANC and press SET.

The menu of parameters is circular. Scrolling is from first to last or from last to first.

When in programming mode, please note that this mode will be cancelled if there is no key activity for a period of 60 consecutive seconds. Programming mode is aborted and all changes will be restored to previous values.

On the following page is an example of how to program a filtration period. When in programming mode you may program as many parameters as needed.

14-B Example: Program filtration period 2 to start at 5:45 PM.

Press	Display	Explanation
SET & DOWN	FP1	Start programming the display, first message is Filtration Period 1.
UP	FP2	Scroll up to Filtration Period 2.
SET	12:00	Select FP2. The display shows the current FP2 start time with the hour portion flashing.
UP	1:00	Increase the hour value by 1.
UP	5:00	Press UP key 4 more times or press and hold for auto repeat.
SET	5:00	The hour is set, the minute portion flashes.
DOWN	5:45	Press UP 15 times or press and hold for auto repeat.
SET	FP2	FP2 set to 5:45 PM and the current message is displayed again.
DOWN	FP1	Scroll to previous message.
DOWN	CANC	Previous message – if you press SET when CANC is displayed, all changes will be discarded.
DOWN	SEND	Previous – save changes.
SET	Temp	Changes saved. Exit programming mode. Display current spa temperature, time or operating message.

The table on the following pages is a list of all menu items, their minimum, default, and maximum values, and an explanation of the function of each parameter.

Note: Time parameters have two components, the hours and the minutes. When programming a time element, first the hour portion is programmed (flashing). When the hours are set press the SET key to program the minutes portion.

15 PARAMETER MENU LISTS

Msg	Min	Def	Max	Detail
FP1		12:00		Start time of filtration period 1.
FP2		12:00		Start time of filtration period 2.
FP3		12:00		Start time of filtration period 3.
FP4		12:00		Start time of filtration period 4.
<p>Note: If filtration periods overlap, the most recent period (last) is in effect.</p>				
SIL		12:00		<p>Start time of filtration period. This is a period during which nothing will run. It overrides all filtrations, the economy cycle, and temperature sampling. Except if temperature drops below 40°F, or if temperature reading drops more than 10°F below the set temperature, then the low speed pump may turn on to prevent the pipes from freezing. A spa may be installed near a bedroom and need not come on at specific times, for example between midnight and 7 in the morning.</p>
FP1d	0	0	240	Duration in minutes FP1 timer will run.
FP2d	0	0	240	Duration in minutes FP2 timer will run.
FP3d	0	0	240	Duration in minutes FP3 timer will run.
FP4d	0	0	240	Duration in minutes FP4 timer will run.
SILd	0	0	12	Duration in hours the Silence Timer runs. Only a user may override the silence timer.

Note: Keep the value of any timer to 0 to keep it from running. Filtration timers must be programmed first one first. If the FP1d (first) timer has duration of 0, Auto Filtration will be in effect and all 4-programmed timers will be disabled.

Msg	Min	Def	Max	Detail
CLDN	30	60	180	Cool Down Cycle (in seconds). Whenever the heater is turned OFF, the pump keeps running the extra seconds to even the temperature of the heater element and the surrounding water to prevent scale buildup and premature heater failure.
ECL	60	180	240	Economy Cycle Length (in minutes). Time in minutes to specify the intervals between spa temperature sampling when the spa is not in use. During this period the spa is in sleep mode. Temperature is sampled at the end of the period. If, during the ECL, the temperature reading drops more than 10°F below the set temperature, the low speed pump may turn on to prevent the pipes from freezing.
CHCL	0	60	180	Channel Clear (in seconds). Time in seconds to clear the air channel and the secondary pump(s) plumbing if the spa has not been used for a period of 24 hours. This prevents water stagnation in the plumbing.
UTO	10	20	60	User Time Out (in minutes). The time in minutes from starting any device, after which all devices will be turned OFF, and the spa put into "not in use mode". If you should leave the spa with a pump or light running, it will be turned off after the specified time.
PUF	30	60	180	Post Use Filtration (in minutes). Time in minutes to perform Post Use Filtration. This is the optimal time to filter the spa. When you have finished using the spa that is when it needs filtration the most. Press the SET key to turn everything OFF and start this cycle. It is in addition to the standard filtration cycle. Pressing any other key will cancel this function.

Msg	Min	Def	Max	Detail
CALB	194	208	218	<p>This is not a time element.</p> <p>It is one of the distinctive features of the control systems. The number is internal and is indicative of what the processor sees as temperature. It is used to calibrate the temperature reading. Increase this value by 1 to decrease the displayed temperature by ½°. Decrease this value by 1 to increase the displayed temperature by ½°. For example, if the controller is displaying a temperature 2 lower than the real temperature, increase this value by 4 to get a correct reading. The total range of this parameter is 10° Fahrenheit. Before doing a calibration please read the warning note at the bottom of the page.</p>
SEND				<p>This menu message has no numerical value.</p> <p>Pressing SET while it is displayed records and saves all changes made to all parameters.</p>
CANC				<p>This menu message has no numerical value.</p> <p>Pressing SET while it is displayed discards all changes made to all parameters.</p>

WARNING

The recommended maximum temperature of a spa is 104°F. The absolute maximum beyond which no one should ever be exposed is 108°F. When you calibrate the spa temperature you are doing so at your own risk. Obtain an accurate medical thermometer to check against. Please contact Acura Spa Systems, Inc. for proper procedure or if you do not feel confident.

16 PROGRAMMING SYSTEM OPTIONS

Systems Options Programming is a means of setting the various system options. The U and P options are of the ON/OFF or 1/0 type; the option is either 1 or ON or it is 0 or OFF. The D options can only be displayed and may not be changed by the user. To initiate options programming, press the UP and DOWN arrows together. There are 3 groups of 8 options each:

User Options U1 to U8

Protected Options P1 to P8

Diagnostics D1 to D8

When programming groups 1 and 2 (U and P options), either the letter U or the letter P is displayed followed by a number (1 to 8), a space and the number 1 if the option is ON or 0 if the option is OFF. For example, if the third user option was OFF the letters U3 0 will be displayed. If it was ON the display will read U3 1.

Use the scroll buttons (UP and DOWN) to navigate through the different options. Press the SET key to toggle a displayed option's status from 0 to 1 or vice versa. Go to SEND and press SET to save changes. Alternatively, go to CANC and press SET to discard all changes and restore previous settings.

The Diagnostics are not options, but rather they display internal values that are indicative of the internal state of the processor. They are useful for a serviceman or a technician to pinpoint hardware problems and error conditions.

The following tables list the User Options and the Protected Options and their significance when they are ON and OFF.

16-A User Options

- U1 0 = Economy mode is ON. In this mode, water temperature is sampled every 3 hours or whatever ECL is set to. If the spa is being used, the economy mode is OFF.
 1 = Auto Maintenance is ON. Temperature is sampled and acted upon continuously.
- U2 0 = Low pump on demand. The low pump will come on to sample the temperature, heat or filter the spa as needed.
 1 = The low pump runs all the time.
- U3 0 = Auto Filtration is one 3 hour long period. The length of this period is fixed and cannot be changed. It is the minimum recommended filtration time for a spa.
 1 = Auto Filtration is two periods each 3 hours long. The second period starts 12 hours after the first period is executed.
- U4 0 = User timer starts with the first key pressed and shuts the spa off at the end of countdown.
 1 = The user timer is restarted every time a key is pressed.
- U5 0 = Display TOD, time of day the first 10 seconds of every minute, if the time of day has been set.
 1 = Do NOT display TOD. If TOD was not set by the user then it most probably is incorrect and the controller will not display it even if U5 is 0.
- U6 0 = If line frequency is 60 hz, then display temperature in Fahrenheit. If 50 hz then display Centigrade.
 1 = If line frequency is 60 hz, then display temperature in Centigrade. If 50 hz then display Fahrenheit.
- U7 RESERVED, do not change. Leave set to 0.
- U8 RESERVED, do not change. Leave set to 0.

The default setting for all U options is 0.

16-B Protected Options

Warning: Changing any of the protected options may be dangerous and can result in injury. It can also damage the spa and its equipment as well. Changes made by the user are at his/her own risk. All liability rests with the person doing the changes. Only trained service personnel should make changes. If unsure, please contact Acura Spa Systems, Inc.

- P1 0 = There is no additional circulating pump. The primary pump is usually 2-speed. The low speed is the filtering and heating pump.
1 = A circulating pump is attached to the system.
- P2 0 = The primary pump is a 2-speed pump.
1 = The primary pump is a single speed pump.
Note: The circulating pump is always attached through the heater. All filtration and heating is done with the circulating pump when one is attached to the system.
- P3 0 = The system has high amps available.
1 = The system is only capable of 20 or 30 amps (low power). In this mode the heater can only operate with the low or circulating pump. It is disabled with all other selections.
- P4 0 = The LITE key operates as an ON/OFF switch. The light relay and the accessory relay (if installed) operate together.
1 = The LITE key is a 3 function key.
 - Press once, the spa light is turned ON.
 - Press again, both spa light is ON and accessory is ON.
 - Press a third time for both functions to turn OFF.
- P5 0 = Reserved. Do not use this function.
- P6 0 = Air blower is enabled. The AIR key is active.
1 = Air blower is disabled. The AIR key is deactivated.
- P7 0 = Secondary pump is a single speed pump.
1 = Secondary pump is a dual speed pump.
- P8 0 = There is only one secondary pump.
1 = There are two secondary pumps.
Note: If P8 is ON, then by definition both secondary pumps must be single speed.

Warning: An improper setting of P7 and P8 can result in damage or even destroyed pump motors. It can also cause the controller's printed circuit board to catch fire. Only trained service personnel should carry out changes. If unsure, please contact Acura Spa Systems, Inc.

16-C Diagnostic Values

The D options are internal values and may not be changed from the control panel. When a D message is displayed, press the SET key to see what the associated value is. Here is a brief explanation:

- D1 What the microprocessor is reading as relative temperature.
- D2 What the microprocessor is reading from the keys.
- D3 What the microprocessor is sending to the relays.
- D4 Accumulated count of temperature errors encountered.
- D5 Accumulated count of hi limit errors encountered.
- D6 Accumulated count of heartbeat errors encountered.
- D7 The firmware revision number.
- D8 The manufacturing year and week in the form yyww.

16-D Megatrol™ Indicator Lights

Megatrol™ Indicator Lights

- A = 120V Power Supply to Terminal Block (L1, N)
 - B = 240V Power Supply to Terminal Block (L1, L2)

 - C = Low Pump "ON"
 - D = High Pump "ON"
 - E* = 2nd Pump High "ON"
 - F* = 3rd Pump High "ON" OR 2nd Pump Low "ON"
 - G* = 4th Pump High "ON"
 - H* = Blower "ON"

 - I = Heater 1 "ON"
 - J* = Heater 2 "ON"
- * Optional Items

The indicator lights provided on the upper left side of the Megatrol™ series indicate the A/C Power supply to the control box as well as the A/C Power from the control box to the Pump(s), Heater(s), and Blower (if installed). The Indicator Lights are defined as:

- A 120V Power Supply to Terminal Block (L1, N)**
Indicator light "A" is ON, 120 Volts is supplied to the Terminal Block.
Indicator light "A" is OFF, 120 Volts is not supplied to the Terminal Block.

- B 240V Power Supply to Terminal Block (L1, L2)**
Indicator light "B" is ON, 240 Volts is supplied to the Terminal Block.
Indicator light "B" is OFF, 240 Volts is not supplied to the Terminal Block.

- C Low Pump Low Pump ON**
Indicator light "C" is ON, voltage is measured on the control box receptacle between the white and red wires. If the pump is wired correctly, then the low speed pump is ON. If the low speed pump is not ON, then:
 - C1 The pump motor is bad.
 - C2 The motor has a tripped thermo overload due to high ambient temperature in the equipment bay (ambient temperature higher than 122°F).
 - C3 Voltage drop below 216 Volts may cause the motor to overheat.
A marked 230 Volt motor will not operate below 207 Volts 60 Hz.
A marked 115 Volt motor will not operate below 104 Volts 60 Hz.Indicator light "C" is OFF
 - C4 If indicator light "B" is ON and the low pump indicator on the Top Side control is ON, then the PC board relay is not engaging.

Change the PC Board (removing the plastic cover on the relay may free a stuck relay switch).

D High Pump High Pump ON

Indicator light "D" is ON, voltage is measured on the control box receptacle between the white and black wires. If the pump is wired correctly, then the high-speed pump is ON. If the high speed pump is not ON, then:

D1 The pump motor is bad.

D2 The motor has a tripped thermo overload due to high ambient temperature in the equipment bay (ambient temperature higher than 122°F).

D3 Voltage drop below 216 Volts may cause the motor to overheat. A marked 230 Volt motor will not operate below 207 Volts 60 Hz. A marked 115 Volt motor will not operate below 104 Volts 60 Hz.

Indicator light "D" is OFF

D4 If indicator light "B" is ON and the high pump indicator on the Top Side control is ON, then the PC board relay is not engaging. Change the PC Board (removing the plastic cover on the relay may free a stuck relay switch).

I Heater 1 Heater 1 ON

Indicator light "I" is ON, there is voltage on heater terminal. The heater should be heating unless the heating element is bad (to confirm a bad heating element, use an Amp meter and verify the amperage when indicator light "I" is ON).

Indicator light "I" is OFF

If the heater indicator on the Top Side control is ON and the Top Side LED is displaying "PSOL", "PSOH", or "PSOC" refer to section 17-F below.

E, F, G, H, J Pumps, Blower, Heater 2

These are optional items and may or may not be installed in your spa. If these items are installed then the appropriate indicator light(s) will be ON when there is power to that device. The troubleshooting above apply to these items also.

Note: The indicator lights do not display power levels (such as 115 V or 230 V), they only indicate that voltage is ON to that circuit.

17 ERROR MESSAGES

There are 9 error messages that the digital controls may display. Here is a list of these messages and what they indicate:

17-A CoLD Temperature in the spa heater housing is below 40° Fahrenheit. Because spa temperature should never get this low, the status of the heater element is unknown. Therefore the low speed or circulation pump will run continuously until temperature rises above 45°F. A spa should not be filled with water below 40°F. Please note that a running pump can heat the spa at approximately ½°F per hour. During this error condition, the spa is functional except for the heater.

17-B OH OverHeat. The spa is at a temperature that is above 108°F. Control will not accept temperature setting above 104°F. If for some reason, the spa temperature rises over the maximum level, the controller will display a flashing 105°F to 108°F. If temperature goes past 108°F then the OH message will be displayed instead of temperature. The spa is still operational but hotter than any person should be subjected to. Please do not use your spa when the temperature is flashing or the OH message is displayed.

In the summer and especially in warm regions, ambient temperature may be high enough to overheat the spa naturally. Spas are usually well insulated and can store a lot of heat in the equipment compartment.

17-C HLEr Hi Limit Over Heat. Digital controls have a backup water temperature sensor called the Hi Limit. If the sensor is disconnected or shorted, or if the spa temperature should reach above 112°F, the Hi Limit protection circuitry will force all spa functions OFF and will flash the HLEr message on the display. It is not possible to use the spa when this error is active. Even after the temperature goes down to an acceptable level or the sensor is repaired/replaced. When the error has been corrected, you must press the SET key to acknowledge that you, the spa user, are aware of the error condition and should have the proper repairs done.

17-D SEoP Sensor Open. Sensor Open or disconnected and the controller cannot determine the spa temperature. The heater is disabled but the spa is operational. The sensor must be replaced or reconnected for this message to go away.

17-E SESH Sensor Short. The sensor is shorted and is non-functional. Temperature cannot be determined, the heater is disabled, but the spa is still operational. Sensor must be replaced for this message to go away.

17-F PSoC, PSoL, PSoH Pressure Switch Open with Circulating, Low or High Pump(s). The pressure switch is a device sensitive to pressure inside the heater manifold. A pump pushing water through the manifold generates pressure in the heater manifold. If a pump is running and the pressure switch does not sense any pressure, then this is an indication of no water flow. To prevent the heater from being turned on when there is no water running through the manifold, the heater is disabled and one of these messages will be displayed indicating which pump is should be running.

A pressure switch error may also be indicated if the switch is out of adjustment or there is an air lock in the heater manifold. Adjusting the pressure switch is best left to a trained technician. An air lock may happen whenever the spa is drained and refilled with water, or if the water level in the spa is so low as to permit air to be sucked in by the pump. To bleed an air lock, loosen one of the heater fittings and/or a pump fitting a ¼ turn. You will hear the sound of escaping air, then water will start dripping. Re-tighten the fitting. Use air bleeder manual provided by spa manufacturer.

17-G CboH Control Box Overheat. Summer temperatures and a well-insulated spa can cause the ambient temperature in the control box to rise, more so if one or more pumps are running. This error code indicates that the ambient temperature inside the control box is over 115°F and the spa water temperature may not be accurately measured. To eliminate this error, turn the spa off for a time and/or vent the equipment compartment.

17-H ToE Time Out Error. It is not likely that you will ever see this error, it indicates that the system's heartbeat is out of control. All devices will be shutdown and the spa is unusable. This message will rarely ever occur, but if it does, please contact Acura Spa Systems, Inc.

18 ELECTRICAL CONNECTION INSTRUCTIONS

NOTICE: All spa electrical wiring must be performed by a qualified licensed electrician and must meet all NEC (National Electric Code) and state and local codes and requirements.

DANGER – RISK OF ELECTRIC SHOCK

1. The lines carrying power to the spa must be dedicated to the spa and should not be shared with any other appliance(s).
2. All electrical wiring lines must originate from the electrical panel and terminate, hard wired, into the electrical wiring compartment. The use of extension cord or plug type termination is expressly prohibited and voids the warranty.
3. Do not use aluminum wire. Use copper wire only.
4. Wire gauge must be in accordance with NEC requirements for the distance from current source to spa and the current rating as stated on the ID label that is attached to the control enclosure.
5. A grounded metal conduit must shield all wiring. The conduit must be terminated at the electrical access compartment either from the bottom of the spa or through a hole in the side paneling of the spa.
6. For a 120 volt system, the line wire (black) is connected to the terminal block lug labeled LINE1. The neutral wire (white) is connected to the center lug labeled NEUT, and the ground wire (green) is connected to the ground lug labeled G or GROUND.
7. For a 240 volt 4-wire system, connect Line1, Neutral and Ground wires as in #6 above. The fourth wire is the Line2 wire (red) and it is connected to the lug labeled LINE2.
8. For a 240 volt 3-wire system, connect black line wire to LINE1 terminal, connect red line wire to LINE2 terminal and the green wire to the ground lug. There is no neutral.

19 BRANCH CIRCUIT BREAKER REQUIREMENTS

240 Volts	4 Wire System	30/50 Amp 2 Pole Breaker
240 Volts	3 Wire System	30/50 Amp 2 Pole Breaker
120 Volt	3 Wire System	20 Amp 1 Pole Breaker

CAUTION: A new breaker must be used for a new spa installation. Do not use an existing or used breaker.

GFCI. All spa installations must be protected by a GFCI. If your spa control box does not include an integrated GFCI, then you must use a GFCI breaker per National Electrical Code requirements.

Note: If using a GFCI type breaker on a 240 Volt 3-Wire system, the breaker's neutral (white) wire must not be used and should be capped with a wire nut.

120/240 Volt Conversion. All spas are shipped configured for 240 volt (3 or 4 wire systems). Please check the nameplate on the control enclosure to identify the type of system in your spa. If the nameplate indicates a 120/240 Volt type system, then it is possible to convert the spa to 120 volt operation.

30/50 Amp Conversion. Some homes may have limited power service. It is possible to operate a 240 volt spa system using a 30 amp breaker. Connect 240-volt power to the system as previously described, then set it to operate in the low power mode. To set the controller to operate in low power mode, you must set system option P3 to 1. Contact your local dealer about this conversion.

Note: Only experienced service personnel should perform conversions. Improper modifications may cause damage to the control system and/or the attached heater and pump motors.

19-A Terminal Block Electrical Connections

A new breaker must be used for a new spa installation. Do not use an existing breaker, as its condition is unknown.

Breaker	Capacity	Poles	# Wires
240V	40/50 Amps	2	4
120V	20 Amps	1	3

3-Terminal Block Connection

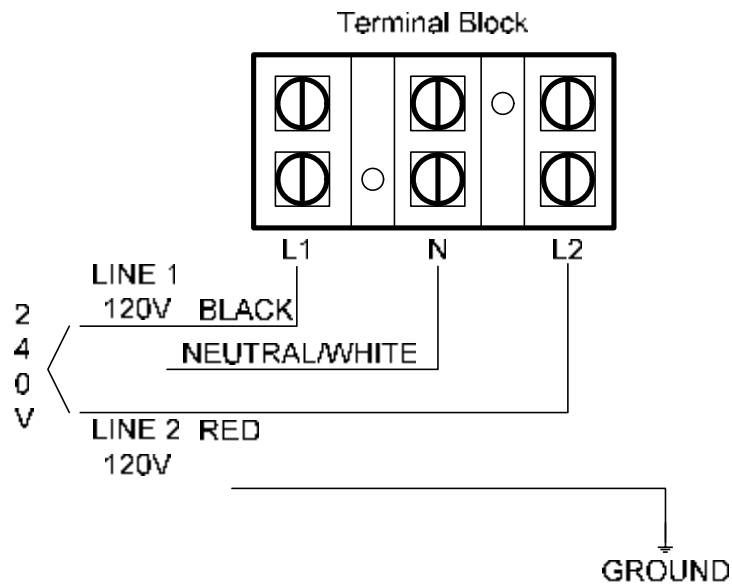

4-Terminal Block Connection

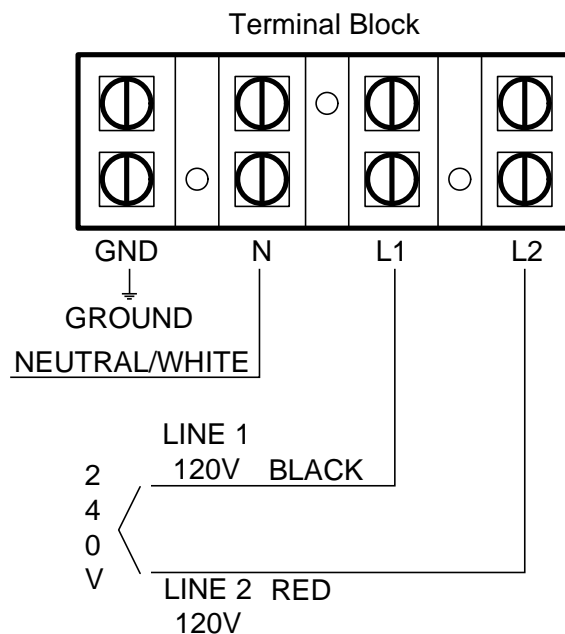

CONDITIONS OF ACURA SPA SYSTEMS LIMITED WARRANTY

ACURA SPA SYSTEMS, INC. ♦ 2954 RUBIDOUX BLVD. ♦ RIVERSIDE, CA 92509 ♦ FAX: 951-684-6677

Acura Spa System Products are warranted to be free of defects in parts and workmanship at time of purchase by the original owner. If this product is found to have a manufacturing defect, Acura Spa Systems will repair or replace defective parts with new or remanufactured ones at our option at no charge to the original owner. Parts used for replacement are warranted for the REMAINDER of this original limited warranty period. For 18 months from date of original purchase or 2 years from date of manufacture (which ever occurs first). Acura Spa Systems will provide replacement of defective parts without charge, subject to the following conditions:

1. Owner must provide verification of the date of purchase when requesting limited warranty service (sales receipt required).
2. All repairs must be performed by an authorized Acura Spa Systems facility. If information is needed in obtaining the location of the nearest authorized service facility, please contact the service department of the factory.
3. Units shipped to service facility must be in original shipping carton and/or properly packed to prevent damage, freight prepaid and fully insured. Acura Spa Systems will return units freight collect. Please include proof of purchase and description of problem with attached "Return Goods Authorization." Do not ship without paper "**Return Goods Authorization**". Please contact the factory to obtain your Return Goods Authorization number. Expenses of shipment and cost of repair of products to an authorized Acura Spa Systems service facility are the responsibility of the purchaser.
4. Installation and removal labor is the responsibility of the purchaser.
5. For warranty to be effective, a maintenance record of regular service must be provided.
6. Installer's electrical license number must be provided.

Warranty Limitations

Limited Warranty provided by Acura Spa Systems does not cover:

- A. Spa shell, spa skirt, modifications of original product or component not part of Acura Spa Systems products.
- B. Any defect, malfunction or failure caused by or resulting from improper service, maintenance, installation or water supply to pump, water chemistry, packaging for return or repairs made or attempted by other than Acura Spa Systems, neglect, accident or any other cause beyond the control of Acura Spa Systems.
- C. Uncrating, set-up or installation, adjustment of customer operated controls.
- D. Any products with serial numbers altered or removed.
- E. Products purchased outside the United States or its possessions.
- F. Commercial or industrial uses.
- G. In no event shall Acura Spa Systems be liable for loss of profits, indirect, consequential or incidental damages.
- H. Aquassage Boot is not warranted against discoloration, cracks, cuts, or misuse. No person, agent, distributor, dealer, service facility or company is authorized to change, modify or amend the terms of this limited warranty in any manner or fashion whatsoever. Except and to the extent provided in this limited warranty, Acura Spa Systems makes no express warranty regarding Acura Spa Systems products.
- I. Pump seals and O-Rings, are only warranted for 90 days, from the original date of purchase. Damage to Seals and O-Rings due to chemicals are not covered by this limited warranty.
- J. Individually purchased parts and products that are not assembled by Acura Spa Systems Inc., are not covered by this limited warranty.
- K. Dry fired heaters, chemically damaged heaters, and corroded heaters are not warranted. Chemicals with acid mordant substances are harmful to the heater's pump seals and other metal components and will void the warranty. Water damaged P.C. boards, improperly installed components, or water damaged components will void the warranty.

- L. All plastic components are warranted to be free from defects in manufacturing. Plastic components are not warranted for cracking, discoloration, fading, warping, or damage during use outside of Acura Spa Systems.
- M. Warranty does not cover damage during shipment. All items shipped from Acura Spa Systems are shipped insured. Please contact the carrier to file a claim.

Further, all implied warranty relating to any portion of this product, including any warranty or merchant ability or fitness, for a particular purpose is limited to the duration of the applicable expressed warranty contained above. Acura Spa Systems shall not be liable to the purchaser or to any other person for any incidental or consequential damages, so the above limitation and exclusions may not apply to you. This warranty gives you specific legal rights and you may also have other rights, which vary from state to state.

Important Notice: In order to allow Acura Spa Systems to better service customer needs, please provide us with model and serial numbers, which are located on the front of your product.

Model No. _____ Serial No. _____

Date Purchased _____ Mfg. Code _____

Dealer Name _____

Dealer Address _____

City _____ State _____ Zip _____

R.G.A.# _____

ACURA SPA SYSTEMS, INC.
2954 RUBIDOUX BLVD.
RIVERSIDE, CA 92509
FAX: 951-684-6677