

*HuskyStar*TM
BY HUSQVARNA VIKING



USER'S GUIDE

E10

This household sewing machine is designed to comply with IEC/EN 60335-2-28 and UL1594

IMPORTANT SAFETY INSTRUCTIONS

When using an electrical appliance, basic safety precautions should always be followed, including the following:
Read all instructions before using this household sewing machine.

DANGER - To reduce the risk of electric shock:

- A sewing machine should never be left unattended when plugged in. Always unplug this sewing machine from the electric outlet immediately after using and before cleaning.
- Always unplug before relamping. Replace bulb with same type rated 10W (110V-120V), 15W (220-240V).

WARNING - To reduce the risk of burns, fire, electric shock, or injury to persons:

- Do not allow to be used as a toy. Close attention is necessary when this sewing machine is used by or near children and infirm persons.
- Use this sewing machine only for its intended use as described in this manual. Use only attachments recommended by the manufacturer as contained in this manual.
- Never operate this sewing machine if it has a damaged cord or plug, if it is not working properly, if it has been dropped or damaged, or dropped into water. Return the sewing machine to the nearest authorized dealer or service center for examination, repair, electrical or mechanical adjustment.

- Never operate the sewing machine with any air openings blocked. Keep ventilation openings of the sewing machine and foot controller free from the accumulation of lint, dust, and loose cloth.
- Keep fingers away from all moving parts. Special care is required around the sewing machine needle.
- Always use the proper needle plate. The wrong plate can cause the needle to break.
- Do not use bent needles.
- Do not pull or push fabric while stitching. It may deflect the needle causing it to break.
- Switch the sewing machine off ("0") when making any adjustment in the needle area, such as threading needle, changing needle, threading bobbin, or changing presser foot, etc.
- Always unplug sewing machine from the electrical outlet when removing covers, lubricating, or when making any other user servicing adjustments mentioned in the instruction manual.
- Never drop or insert any object into any opening.
- Do not use outdoors.
- Do not operate where aerosol (spray) products are being used or where oxygen is being administered.
- To disconnect, turn all controls to the off ("0") position, then remove plug from outlet.
- Do not unplug by pulling on cord. To unplug, grasp the plug, not the cord.

SAVE THESE INSTRUCTIONS

Congratulations!

As the owner of a new sewing machine, you will enjoy precision quality stitching on all types of fabrics, from multiple layers of denim to delicate silks.

Your sewing machine offers the ultimate in simplicity and ease of operation. For your safety and to fully enjoy the many advantages and ease of operation of your sewing machine, we recommend that you read all the important safeguards and use and care instructions in this instruction book.

May we suggest that before you start to use your sewing machine, you discover the many features and advantages by going through this instruction book, step by step, while seated at your sewing machine.

To ensure that you are always provided with the most modern sewing capabilities, the manufacturer reserves the right to change appearance, design or accessories of this sewing machine when considered necessary.

LIST OF CONTENTS

PRINCIPAL PARTS OF THE MACHINE.....	5
ACCESSORIES	7
FITTING THE SNAP-IN ACCESSORY BOX.....	8
CONNECTING THE MACHINE TO POWER SOURCE.....	9
Foot control	9
Sewing light.....	9
CHANGING THE BULB.....	10
TWO-STEP PRESSER FOOT LEVER/ADJUST PRESSER FOOT PRESSURE ...	11
ATTACHING THE PRESSER FOOT SHANK/ANKLE.....	12
WINDING THE BOBBIN.....	13
INSERTING THE BOBBIN	14
INSERTING THE NEEDLE	15
THREADING THE UPPER THREAD	16
THREAD TENSION.....	17
BRINGING UP THE BOBBIN THREAD	18
REVERSE SEWING/REMOVING THE FABRIC/CUTTING THE THREAD	19
MATCHING NEEDLE / FABRIC / THREAD	20
STRAIGHT STITCHING	21
ZIGZAG STITCHING.....	22
HOW TO SEW BUTTONHOLES.....	23
BLIND HEM.....	25
ZIPPERS AND PIPING	26
3-STEP ZIG-ZAG	27
STITCH SELECTION	28
MAINTENANCE	29
TROUBLE SHOOTING GUIDE.....	30

PRINCIPAL PARTS OF THE MACHINE

1. Thread tension dial
2. Presser foot pressure
3. Thread take-up lever
4. Thread cutting
5. Presser foot
6. Needle plate
7. Accessories box
8. Bobbin stop
9. Stitch length dial
10. Stitch display
11. Reverse sewing lever

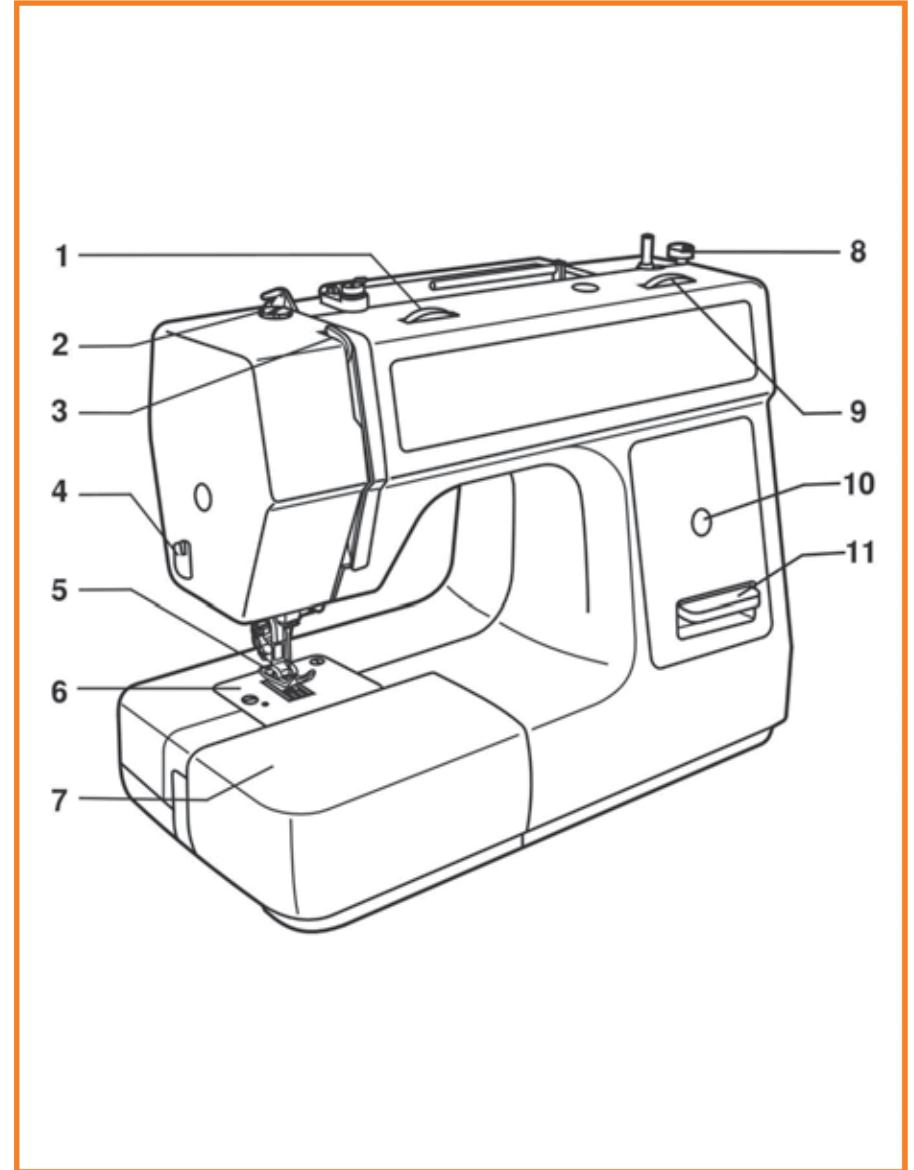

- 12. Spool pin
- 13. Bobbin winder
- 14. Hole for second spool pin
- 15. Hand wheel
- 16. Stitch selector dial
- 17. Power switch
- 18. Main plug socket
- 19. Bobbin thread guide
- 20. Upper thread guide
- 21. Handle
- 22. Presser foot lever

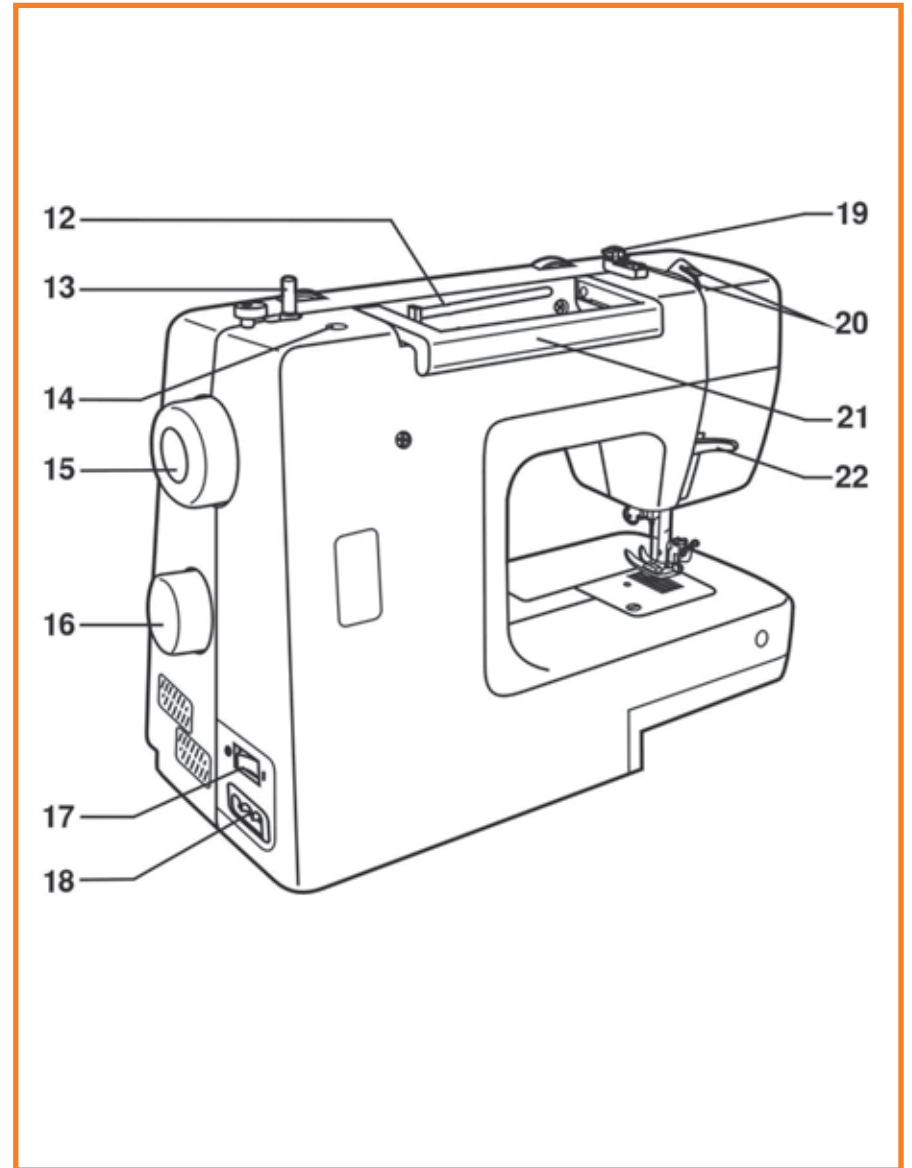

ACCESSORIES

1. All purpose foot
2. Zipper foot
3. Satin stitch foot
4. Blind hem foot
5. Buttonhole foot
6. L-screwdriver
7. Seam ripper/ brush
8. Oil bottle
9. Second spool pin
10. Spool holders (2x)
11. Pack of needles
12. Seam guide
13. Bobbins (3x)
14. Darning plate
15. Felt pad

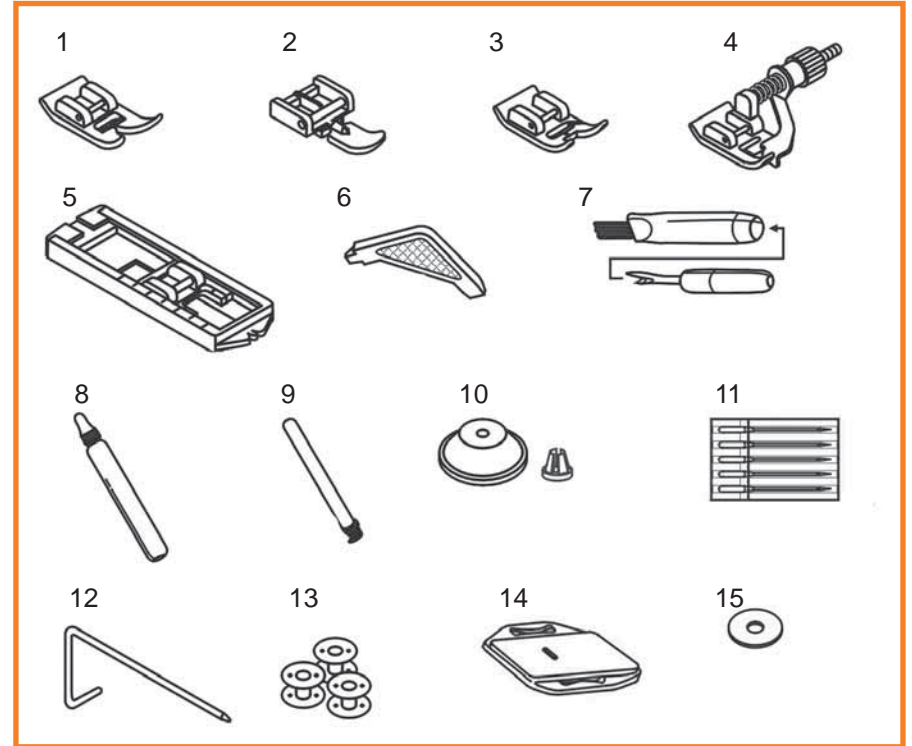

FITTING THE SNAP-IN ACCESSORY BOX

Keep the snap-in accessory box horizontal, and push it in the direction of the arrow. (1)

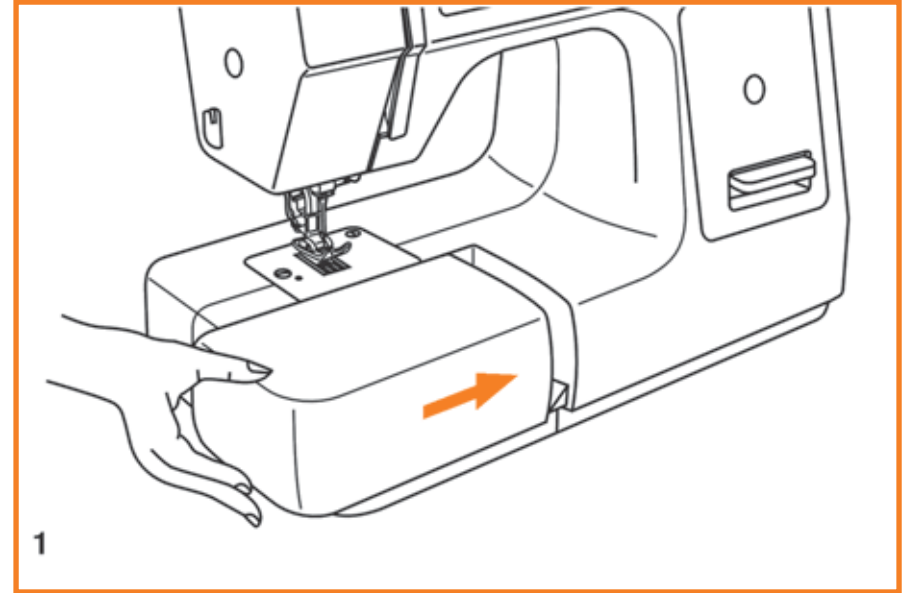

To open, lift up at the point of the arrow. (2)

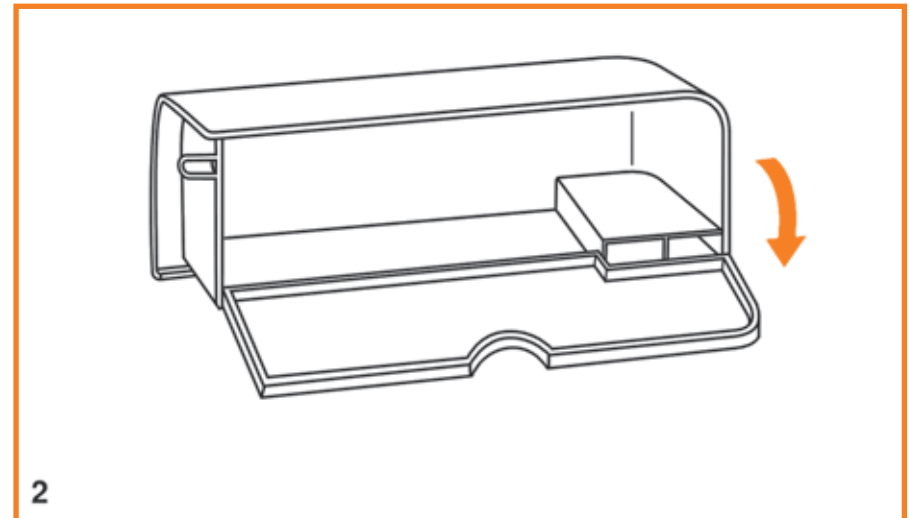

CONNECTING THE MACHINE TO POWER SOURCE

Connect the machine to a power source as illustrated. (1)
A polarized plug must be used with the appropriate polarized outlet.
(2)



Attention:

Unplug power cord when machine is not in use.

Foot control

Foot control regulates the sewing speed. (3)



Attention:

Consult a qualified electrician if in doubt as to how to connect machine to power source.

Unplug power cord when machine is not in use.

The appliance must be used with the foot controller:

- For USA and Canada, 110-120V: 4C-316B
- For Australia, 240V: 4C-326G
- For Europe, 220-240V: 4C-316C or 4C-326C

Sewing light

Press main switch (A) for power and light on. (" I ")

For USA and Canada

For appliance with a polarized plug (one blade is wider than the other).

To reduce the risk of electric shock, this plug is intended to fit in a polarized outlet only one way. If it does not fit fully in the outlet, reverse the plug. If it still does not fit, contact a qualified electrician to install the proper outlet. Do not modify the plug in any way.

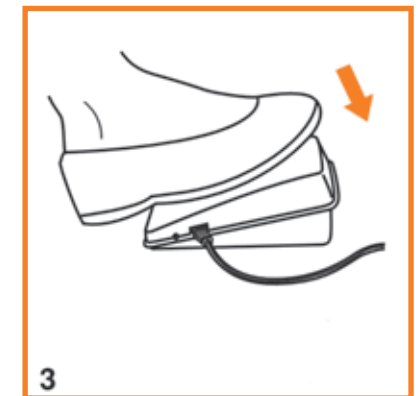
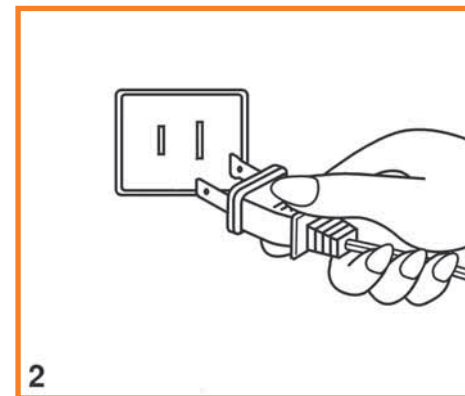
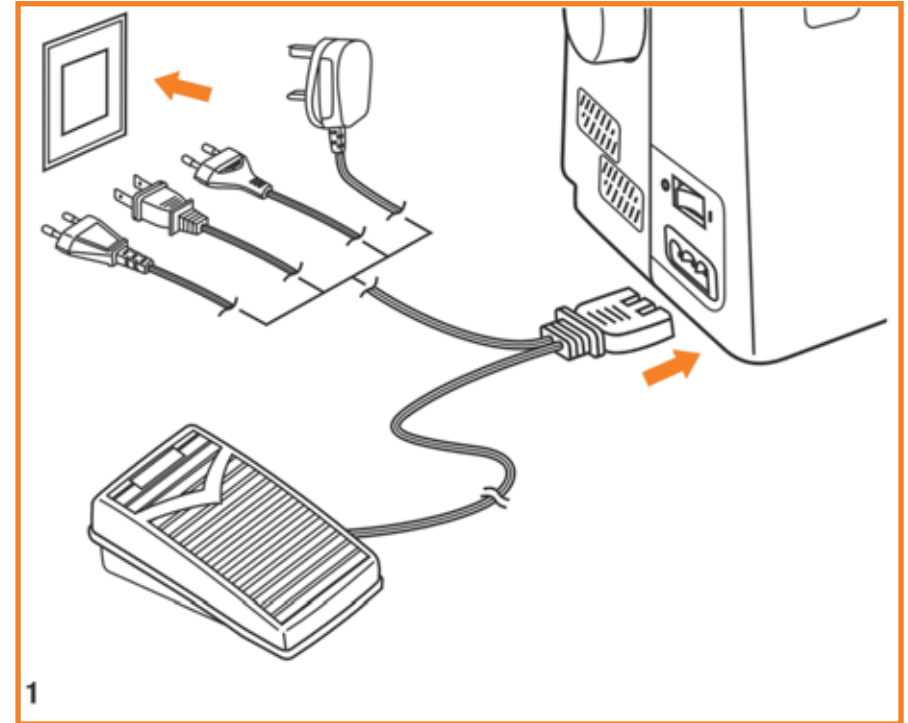

CHANGING THE BULB



Attention:

Disconnect the machine from the power supply by removing the plug from the main socket!

Replace bulb with same type rated 10 watts (110-120V) or 15 watts (220-240V).

- Loosen screw (A) as illustrated. (1)
- Remove the cover (B).
- Unscrew the bulb and fit new one (C). (2)
- Replace the cover and tighten screw.

Should there be any problem, ask your local dealer for advice.

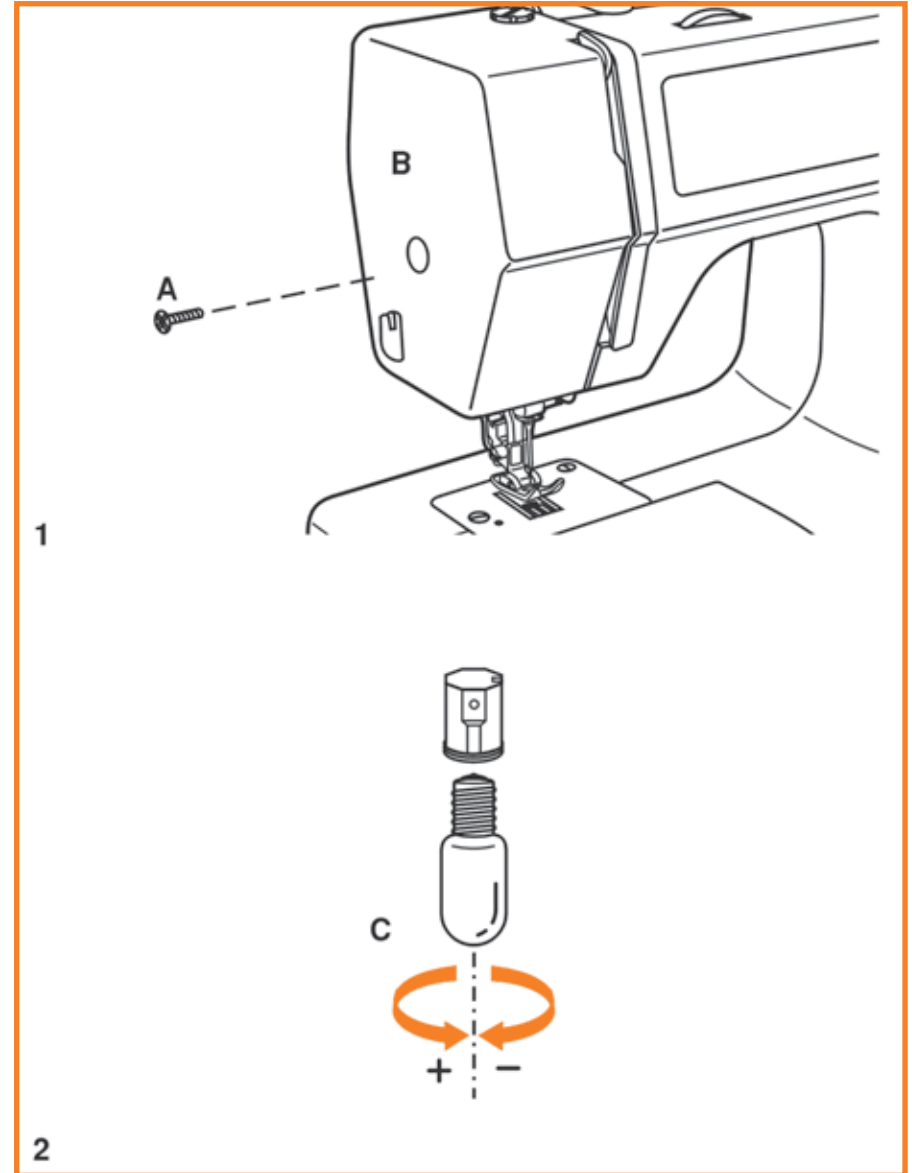

TWO-STEP PRESSER FOOT LEVER

When sewing several layers or thick fabrics, the presser foot can be raised to extra high for easy positioning of the work. (A)

ADJUST PRESSER FOOT PRESSURE

The presser foot pressure of the machine has been pre-set and usually requires no readjustment for most fabrics (light-or-heavy weight).

However, if you need to adjust the presser foot pressure, turn the presser adjusting screw with a coin.

For sewing very thin fabric, loosen the pressure by turning the screw counter clockwise for less pressure on the fabric, and for heavy fabric, tighten by turning it clockwise for more pressure on the fabric.

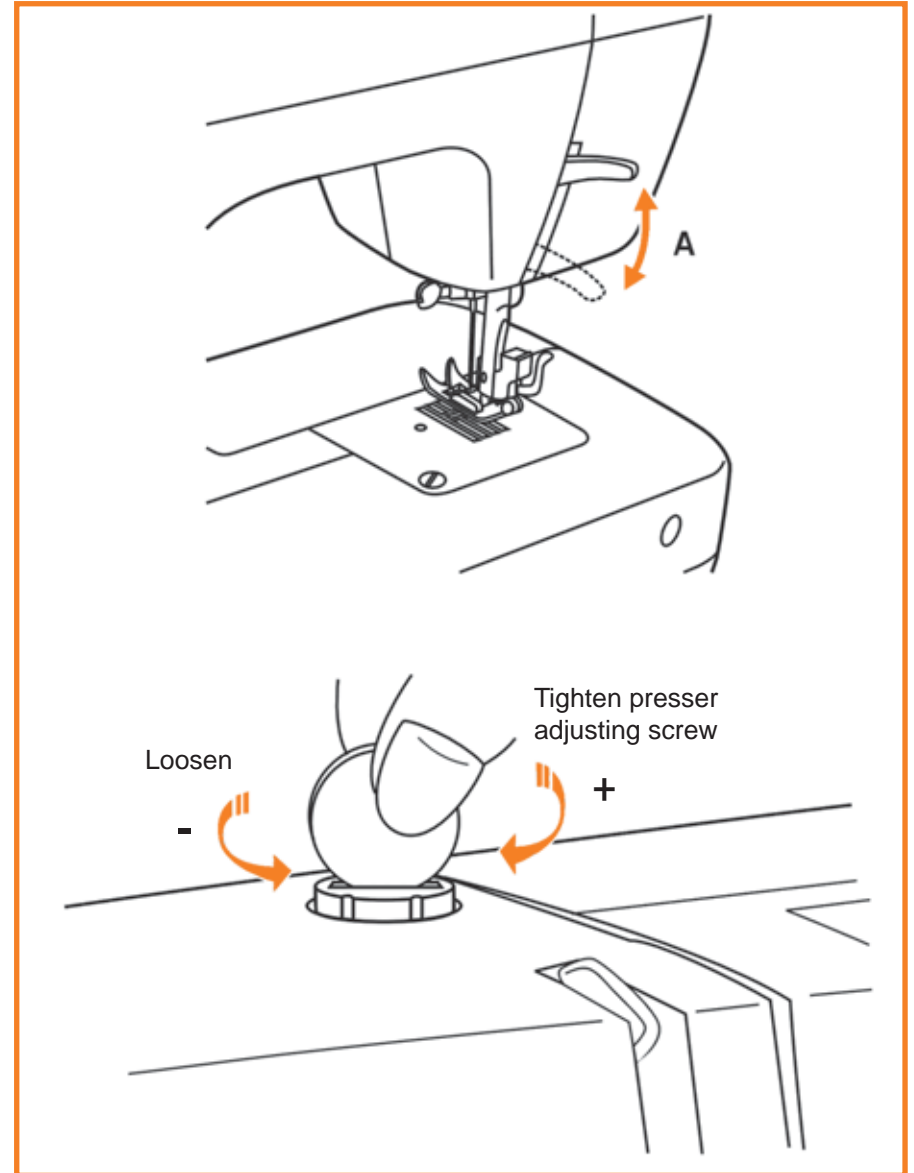

ATTACHING THE PRESSER FOOT SHANK/ ANKLE

Attaching the presser foot holder

Raise the presser foot bar (a). (1)

Attach the presser foot shank/ankle (b) as illustrated.

Attaching the presser foot

Lower the presser foot shank/ankle (b) until the cut-out (c) is directly above the pin on the foot (d). (2)

Raise the lever (e).

Lower the presser foot shank/ankle (b) and the presser foot (f) will engage automatically.

Removing the presser foot

Raise the presser foot. (3)

Raise the lever (e) and the foot disengages.

Attaching the seam guide

Attach the seam guide (g) in the slot on the shank/ankle as illustrated.

Adjust according to need for hems, pleats, quilting, etc. (4)

Attention:

Turn power switch to off ("O") when carrying out any of the above operations!

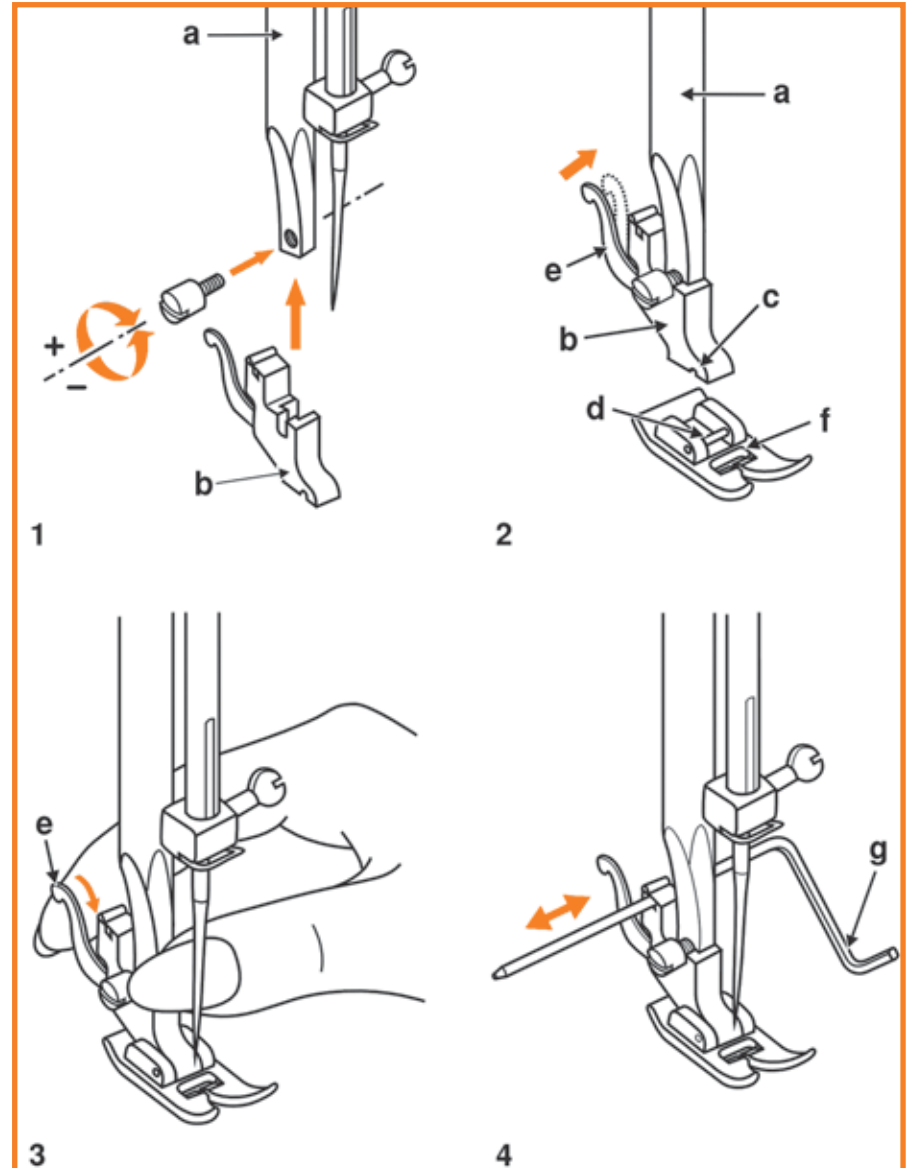

WINDING THE BOBBIN

Place thread and spool holder onto spool pin (1).

- For smaller spools of thread place spool holder with small side next to spool (2).
- Wind thread clockwise around bobbin winder tension discs (3).
- Thread bobbin as illustrated and place on spindle (4).
- Push bobbin to right (5).
- Hold thread end (6).
- Step on foot control pedal (7) to wind the bobbin.
- Cut thread (8).
- Press bobbin to left (9) and remove.

Please Note:

When the bobbin winder spindle is in "bobbin winding" position, the machine will not sew and the hand wheel will not turn.

To start sewing, push the bobbin winder spindle to the left (sewing position).

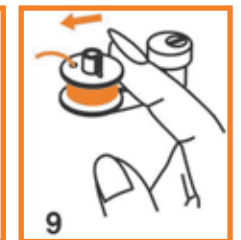
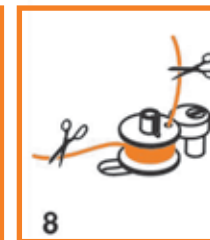
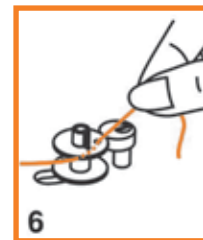
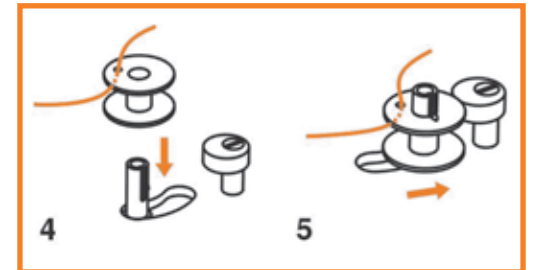
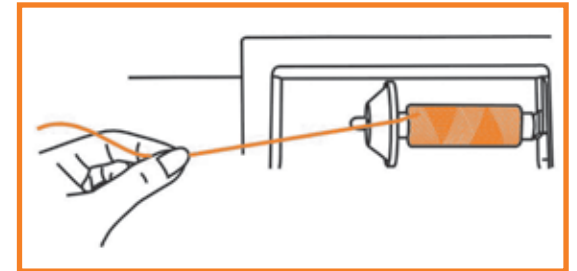
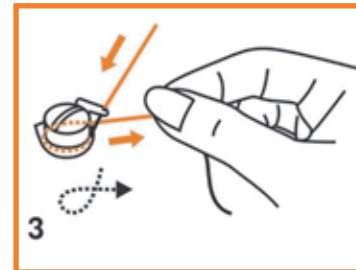
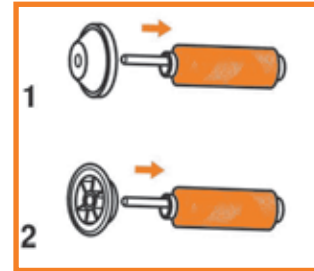
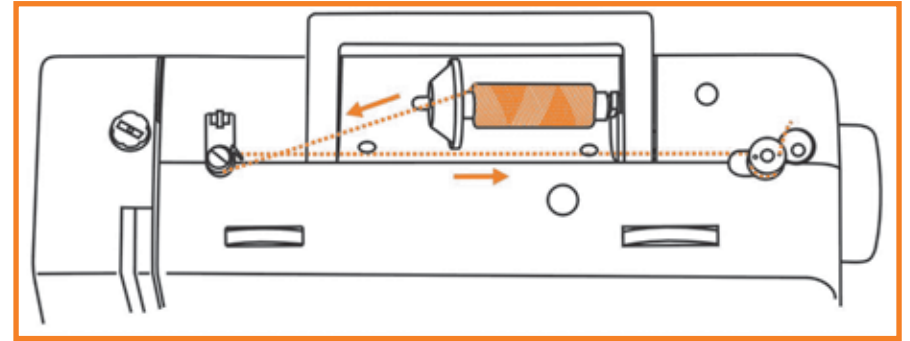

INSERTING THE BOBBIN

When inserting or removing the bobbin, the foot and needle must be fully raised.

1. Open the hinged cover.
2. Hold the bobbin case with one hand. Insert the bobbin so that the thread runs in a clockwise direction (arrow).
3. Put the thread under the tension spring.
4. Hold the bobbin case by the hinged latch.
5. Insert it into the shuttle.



Attention:

Turn power switch to off ("O").

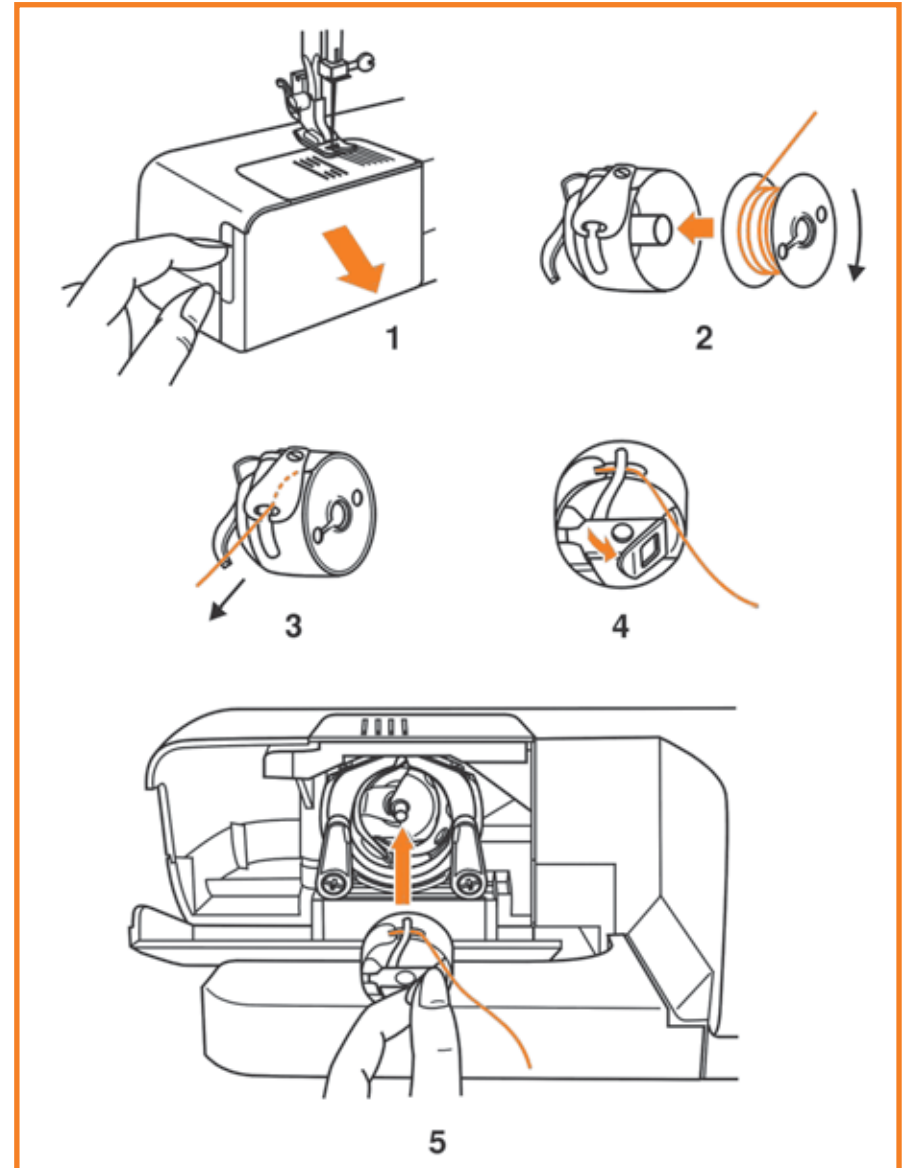

INSERTING THE NEEDLE

Change the needle regularly, especially if it is showing signs of wear and causing problems.

Insert the needle following the illustrated instructions.

- A. Loosen the needle clamp screw and tighten again after inserting the new needle. (1)
- B. The flat side of the needle shaft should be towards the back.
- C/D. Insert the needle as far up as it will go.



Attention:

Turn power switch to off ("O").

Needles must be in perfect condition. (2)

Problems can occur with:

- A. Bent needles
- B. Damaged points
- C. Blunt needles

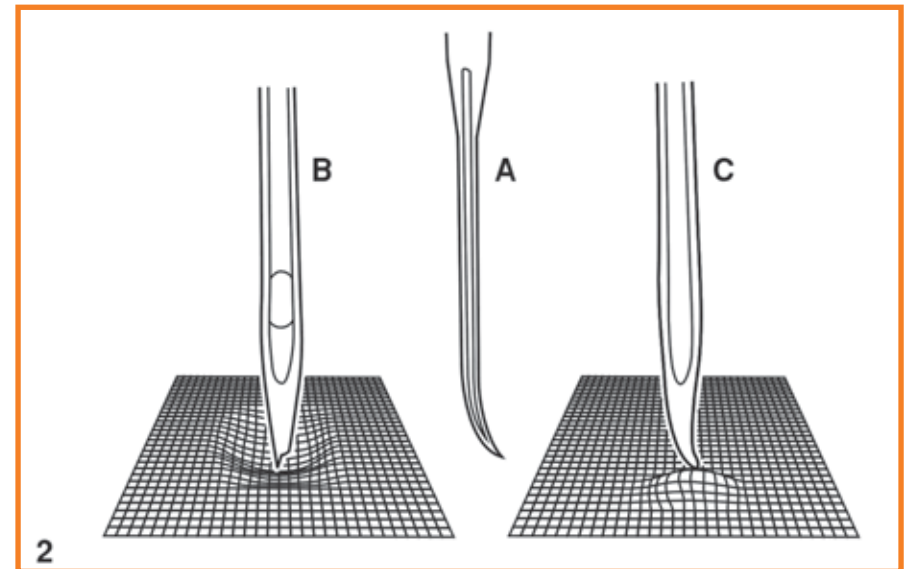
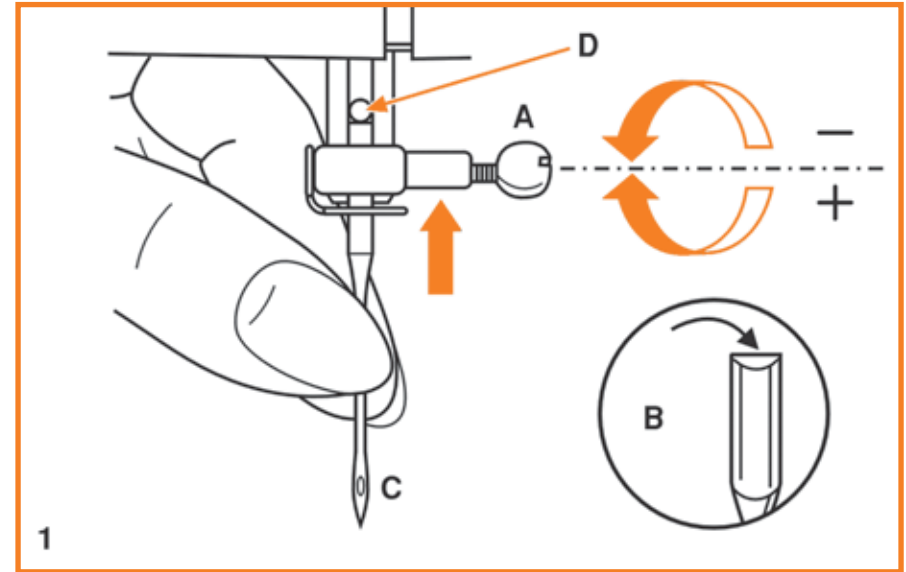

THREADING THE UPPER THREAD

Threading is simple but it is important to thread correctly to prevent sewing problems could result.

- Start by raising the needle to its highest point (1), and also raise the presser foot to release the tension discs. (2)



Attention:

For safety, it is strongly suggested you turn off the power before threading.

- Lift up the spool pin. Place the spool of thread on the holder with the thread coming off the spool as shown. For small thread spools, place small side of spool holder next to spool. (3)
- Draw thread from spool through the upper thread guide. (4)
- Guide thread around thread guide (5) pulling thread through pre-tension spring as illustrated.
- Thread tension disks by leading thread down in right channel and up in left channel (6). During this process it is helpful to hold the thread between the spool and thread guide (4).
- At the top pull thread from right to left through the slotted eye of the take-up lever and then down again. (7)
- Place thread behind the thin wire needle clamp guide (8) and then down to the needle eye and thread from front to back.
- Pull about 6-8 inches of thread under the presser foot to the back. Trim thread to length with built in thread cutter. (9)

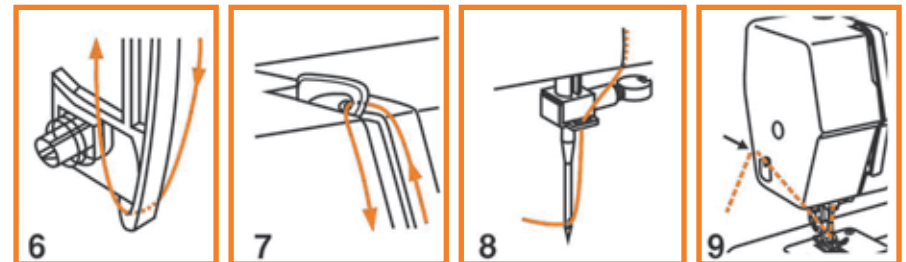
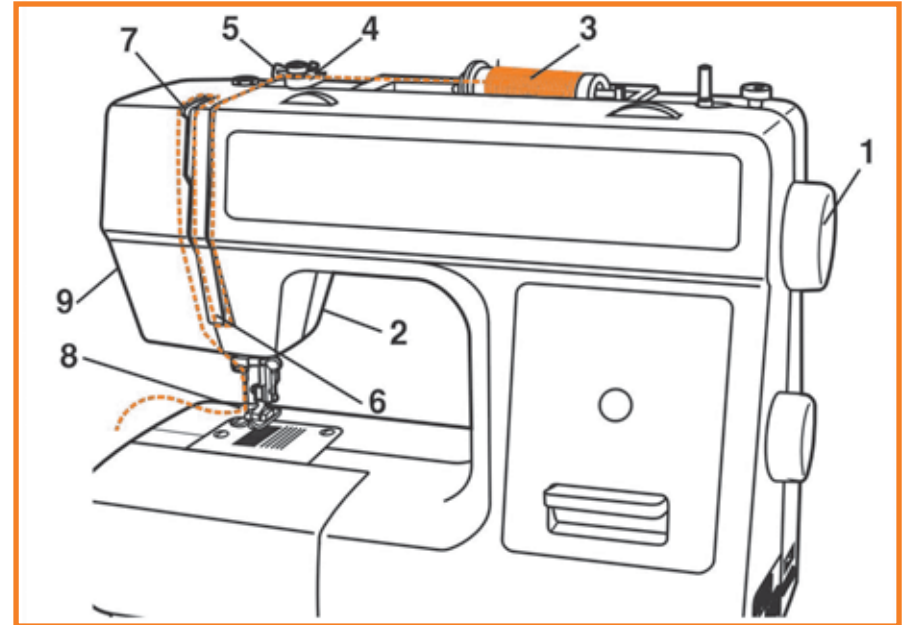
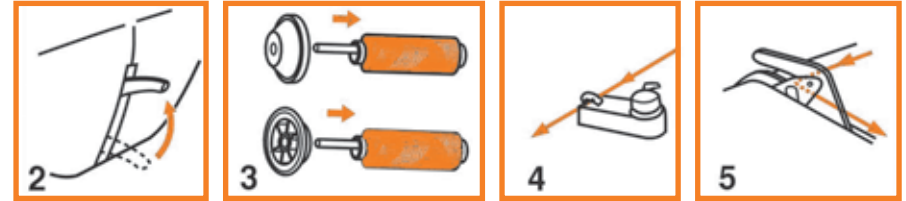

THREAD TENSION

Basic thread tension setting: “4”

To increase the tension, turn the dial to the next number up.

To reduce the tension, turn the dial to the next number down.

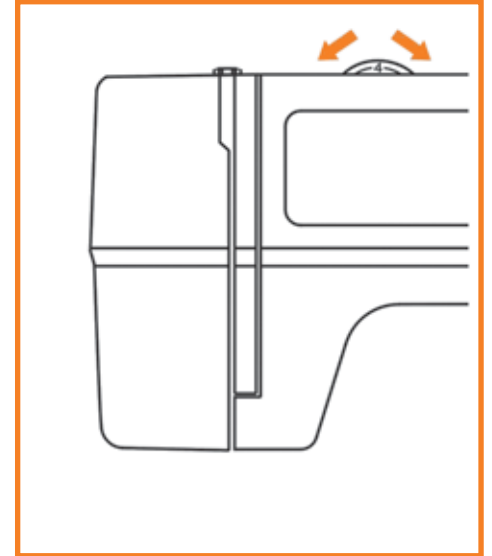

- A. Normal thread tension - upper and bobbin thread join in fabric
- B. Upper thread tension too loose - upper thread “loops” on the underside of fabric
- C. Upper thread tension too tight - bobbin thread “loops” on the top side of the fabric

Note:

The bobbin thread tension does not normally have to be adjusted.

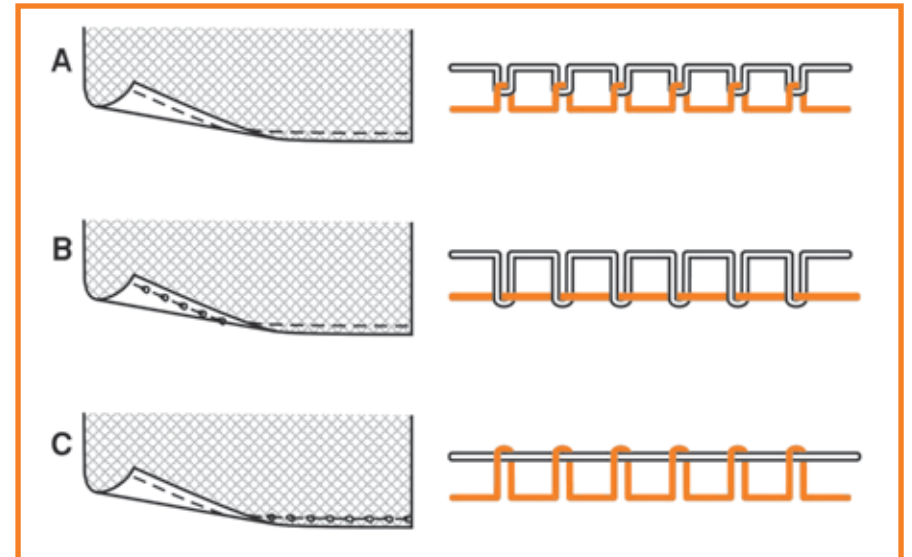

BRINGING UP THE BOBBIN THREAD

Hold the upper thread with the left hand. Turn the handwheel towards you until the needle is raised. (1)

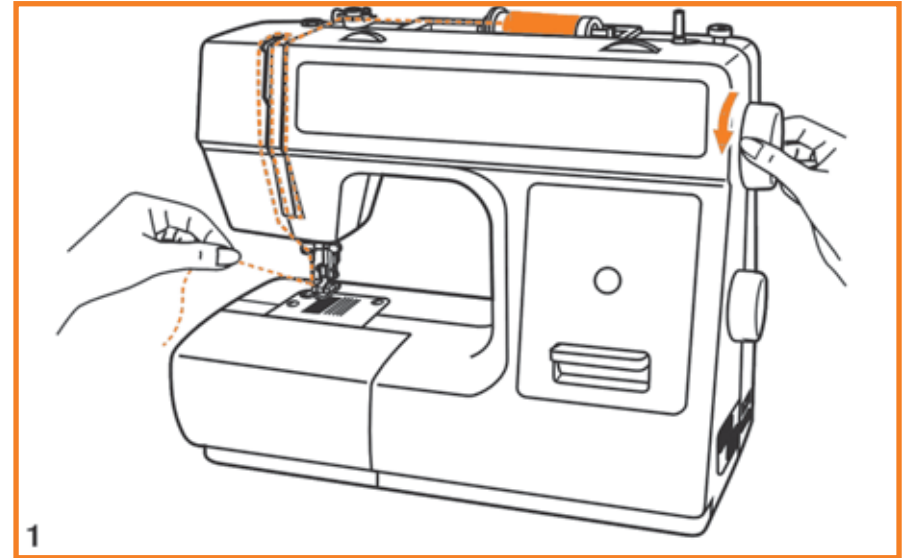

Pull on the upper thread to bring the bobbin thread up through the stitch plate hole.

Place both threads to the back under the presser foot. (2)

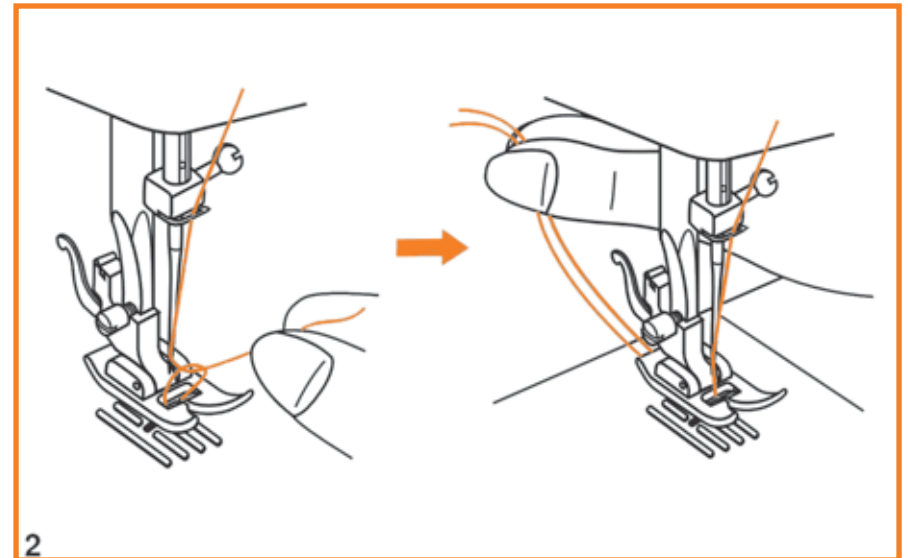

REVERSE SEWING

At the end of a seam, press down the reverse sewing lever. Sew a few reverse stitches to “tie off” the thread ends.

Release the lever and the machine will sew forwards again. (1/A)

REMOVING THE FABRIC

Turn the handwheel toward you to bring the thread take up lever to its highest position, raise the presser foot and remove fabric to the back. (2)

CUTTING THE THREAD

Hold the threads behind the presser foot with both hands, pull them into the thread cutter (B) and down (3) to cut.

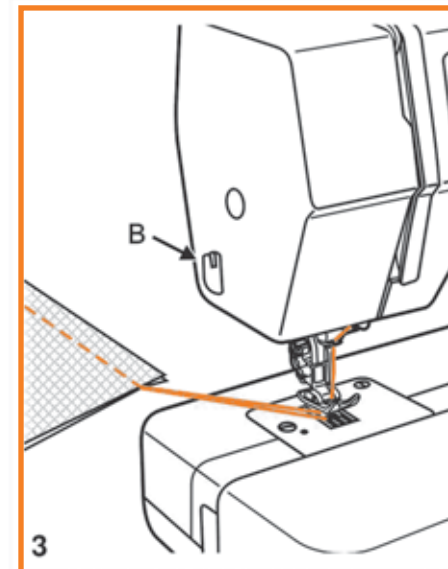
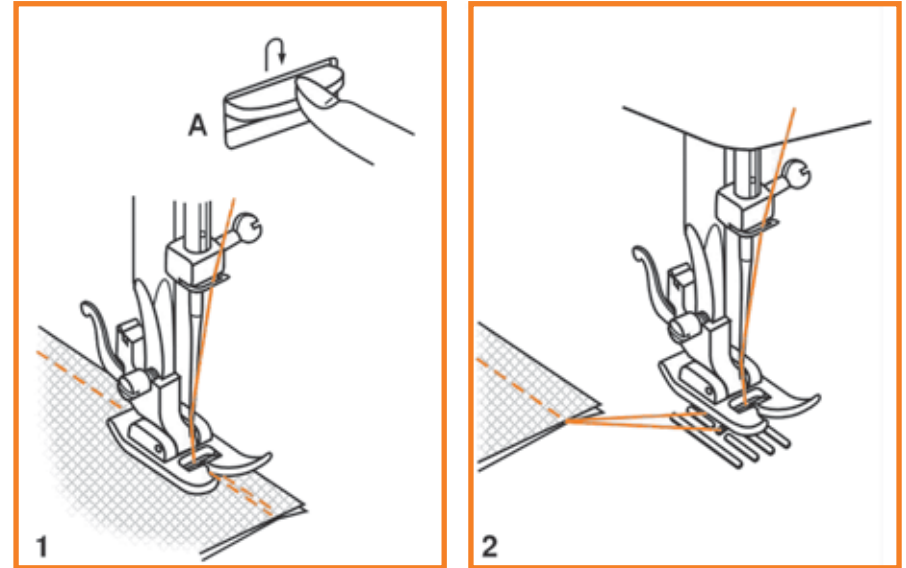

MATCHING NEEDLE / FABRIC / THREAD

NEEDLE, FABRIC, THREAD SELECTION GUIDE

NEEDLE SIZE	FABRICS	THREAD
9-11(65-75)	Lightweight fabrics-thin cottons, voile, silk, muslin, interlocks, cotton knits, tricots, jerseys, crepes, woven polyester, shirt & blouse fabrics.	Light-duty thread in cotton, nylon or polyester.
12(80)	Medium weight fabrics-cotton, satin, kettlcloth, sailcloth, double knits, lightweight wool.	Most threads sold are medium size and suitable for these fabrics and needle sizes. Use polyester threads on synthetic materials and cotton on natural woven fabrics for best results. Always use the same thread on top and bottom.
14(90)	Medium weight fabrics-cotton duck, wool, heavier knits, terrycloth, denims.	
16(100)	Heavyweight fabrics-canvas, wool, outdoor tent and quilted fabrics, denims, upholstery material (light to medium).	
18(110)	Heavy wool, overcoat fabrics, upholstery fabrics, some leathers and vinyls.	Heavy duty thread, carpet thread. (Increase presser foot pressure and top tension.)

IMPORTANT: Match needle size to thread size and weight of fabric

NEEDLE, FABRIC SELECTION

NEEDLES	EXPLANATION	TYPE OF FABRIC
HAx1 15x1	Standard sharp needles. Sizes range thin to large. 9 (65) to 18(110)	Natural woven fabrics-wool, cotton, silk, etc. Qiana. Not recommended for double knits.
15x1/705H(SIN)	Semi-ball point needle, scarfed. 9(65) to 18(110)	Natural and synthetic woven fabrics, polyester blends. Knits-polyesters, interlocks, tricot, single and double knits. Can be used instead of 15x1 for sewing all fabrics.
15x1/705H (SUK)	Full ball point needle 9(65) to 18(110)	Sweater knits, Lycra, swimsuit fabric, elastic.
130 PCL	Leather needles. 12(80) to 18(110)	Leather, vinyl, upholstery. (Leaves smaller hole than standard large needle.)

STRAIGHT STITCHING

Straight stitching center needle position

Turn the stitch selector dial so that the “A” appears in the stitch display window.

Snap on the standard presser foot.

Adjust the stitch length by turning the stitch length dial to the desired stitch length. 2.5 is standard stitch length.

To get the reinforced triple straight stitch, turn the stitch length dial to position “S1”.

Straight stitching right needle position

Turn the stitch selector dial so that the “B” appears in the stitch display window.

Adjust the stitch length by turning the stitch length dial to the desired stitch length.

To get the reinforced triple straight stitch, turn the stitch length dial to position “S1”.

Suggested stitch lengths:

2.0 for lightweight fabrics

2.5 for medium weight fabrics

3.0 for heavy weight fabrics

4.0-5.0 for basting

S1 for stretch fabrics

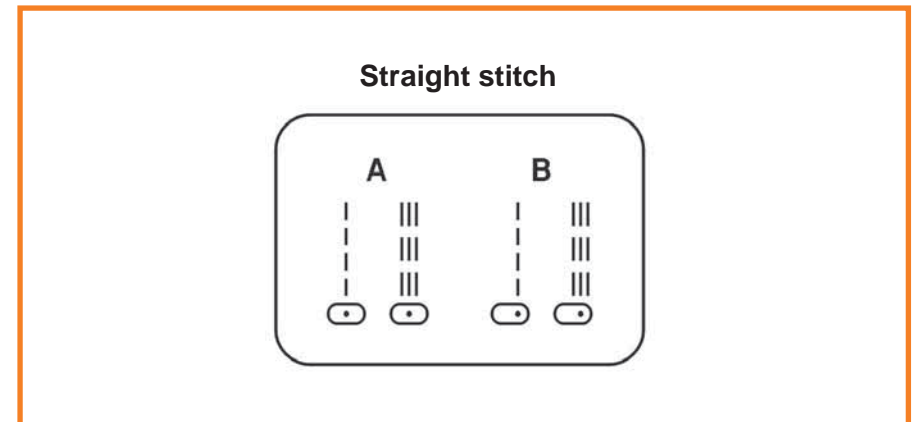
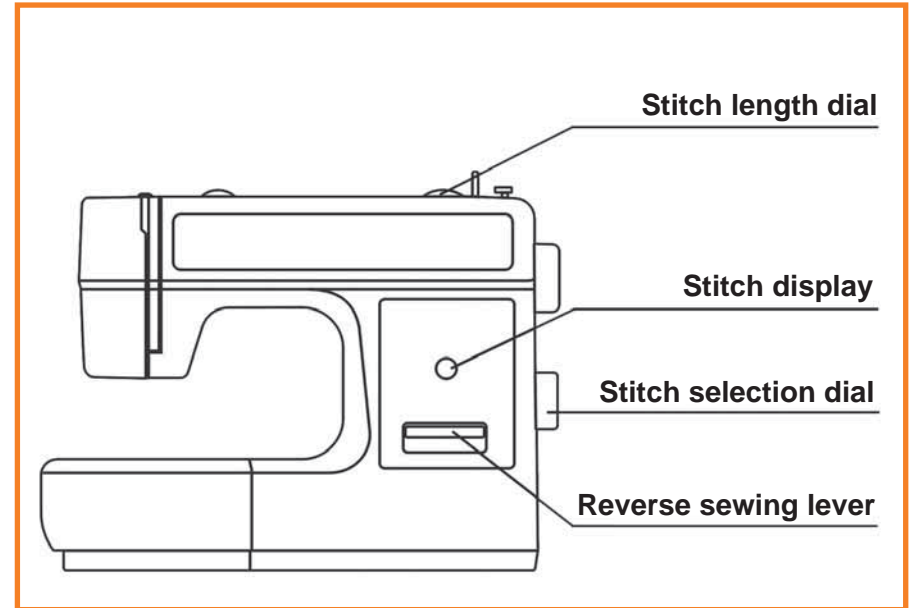

ZIGZAG STITCHING

Turn the stitch selector dial so that the stitch display shows “C”-zigzag. Turning the stitch selector dial will increase or decrease the zigzag width.

Snap on the standard foot.

Function of stitch length dial while zigzaging

The density of zigzag stitches increase as the setting of stitch length dial approaches “0”.

Zigzag stitches are usually sewn at “2.5” or less.

Dense zigzag stitches (close together) are referred to as a satin stitch.

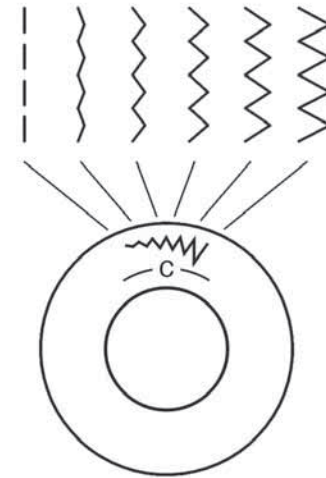

Stitch length dial

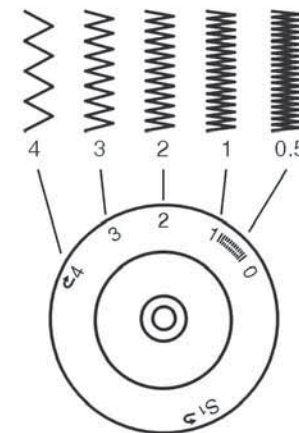

HOW TO SEW BUTTONHOLES

Preparation

Select buttonhole with the stitch Selection dial.

Snap on The buttonhole foot.

Adjust the stitch length dial between “0.5” - “1”.





The density of the stitch depends on thickness of the fabric.

Note: Always test sew a buttonhole.

To prepare the fabric

Measure the diameter of the button and add 0.3 cm (1/8”) for the bartacks. If you have a very thick button, add more to the diameter measurement. Mark the position and length of the buttonhole on the fabric. Position the fabric so that the needle is on the mark that is furthest from you. Pull the buttonhole foot towards you as far as it will go.

Lower the foot.

1. Select buttonhole with the stitch selection dial. Turn the stitch selection dial to (1) “”. Sew at moderate speed until you reach the end mark.
2. Turn the stitch selection dial to (2, 4) “” and sew 5-6 bartack stitches.
3. Turn the stitch selection dial to (3) “” and sew the left side of the buttonhole to the mark at the end which is further from you.
4. Turn the stitch selection dial to (2, 4) “” and sew bar tack stitches.

Remove the fabric from under the foot. Pull the upper thread to the wrong side of the fabric and knot upper and lower threads. Cut the center of the buttonhole with the seam ripper, being careful not to cut the stitches on either side.

Stitch length dial

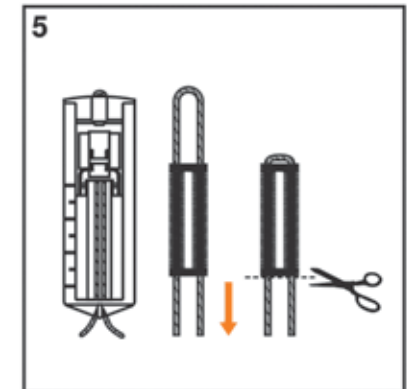
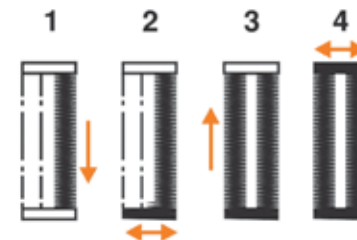
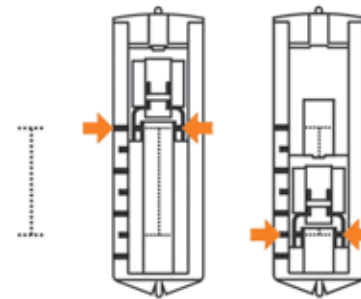
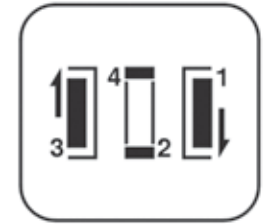
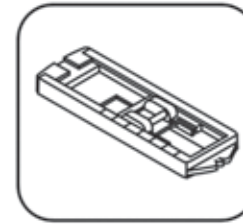





Tips

- Slightly reduce upper thread tension to produce a satin stitch on top.
- Place stabilizer underneath for fine and stretchy fabrics.
- It is best to sew a cord for a buttonhole on a stretch or knit fabrics. The buttonhole columns should sew over the cord. (5)

BLIND HEM

For hems, curtains, trousers, skirts, etc.

Select  Blind hem for stretch fabrics.

Select  Blind hem for woven fabrics.

Snap on Blind hem foot. (1)

Stitch length 1.5-2.5

Note:

It takes practice to sew blind hems.

Always make a sewing test first.

Fold the fabric as illustrated with the wrong side up. (2)

Place the fabric under the foot. Turn the handwheel forwards by hand until the needle swings fully to the left. It should just pierce the fold of the fabric. (3)

Adjust the guide on the foot (4) by turning the knob (5) so that the guide just rests against the fold.

Sew slowly, by pressing the foot control lightly guiding the fabric along the edge of the guide.

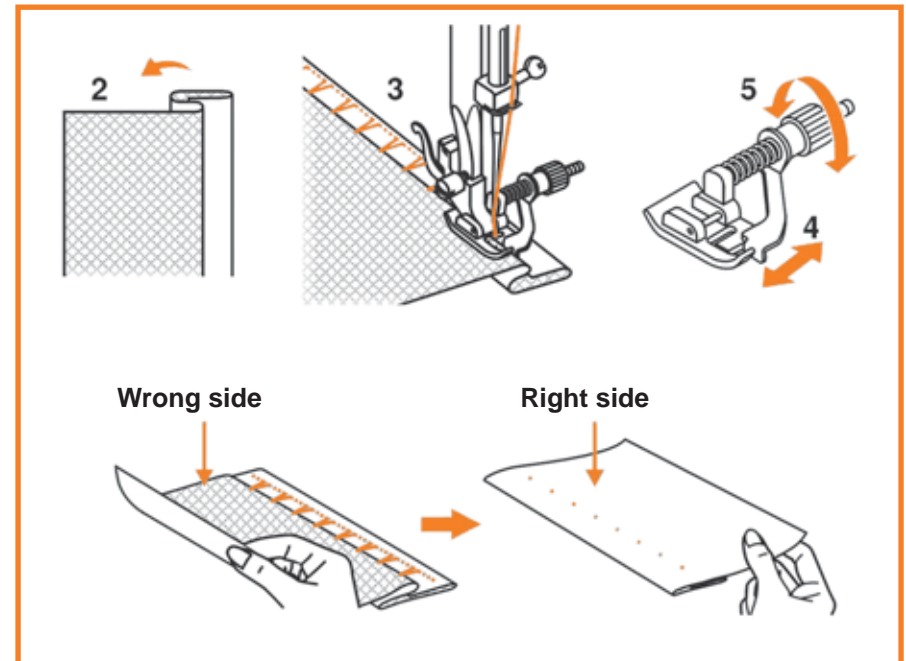
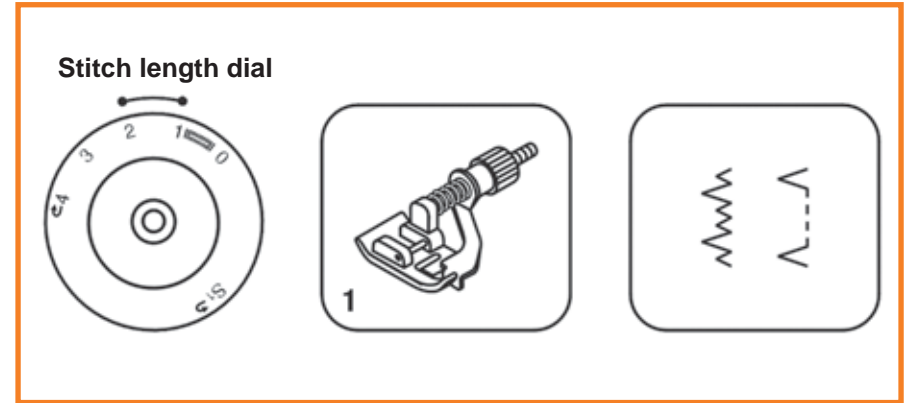

ZIPPERS AND PIPING

Set the machine as illustrated. (1)

The zipper foot can be snapped onto the right or left, depending on which side of the foot you are going to place against the zipper or piping. (2)

To sew past the zipper pull, lower the needle into the fabric, raise the presser foot and push the zipper pull behind the presser foot. Lower the foot and continue to sew.

The zipper foot is also used to sew cord into a bias strip to form a piping and to sew the piping into a seam. (3)

Set stitch length control between “1” - “4” (according to thickness of fabric).

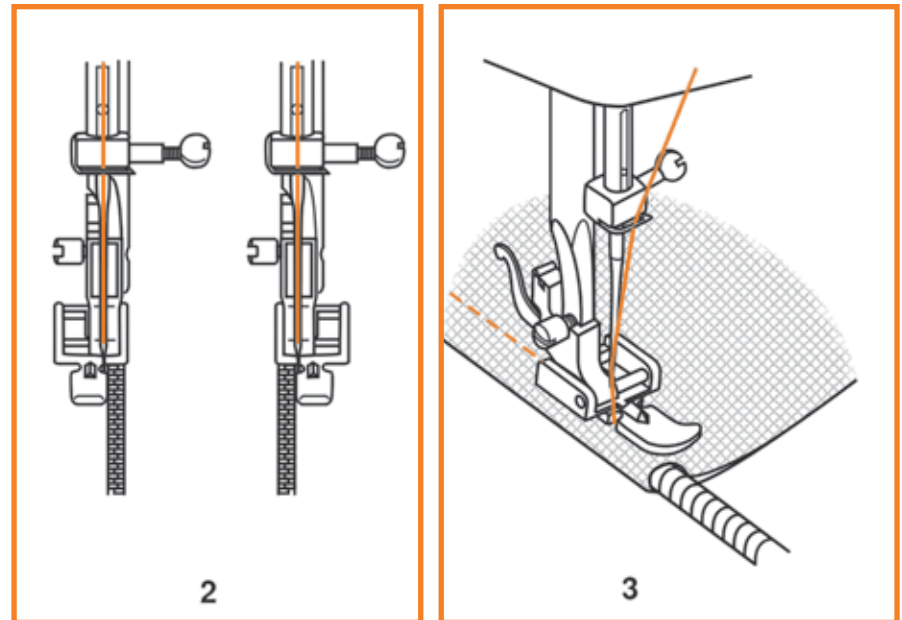
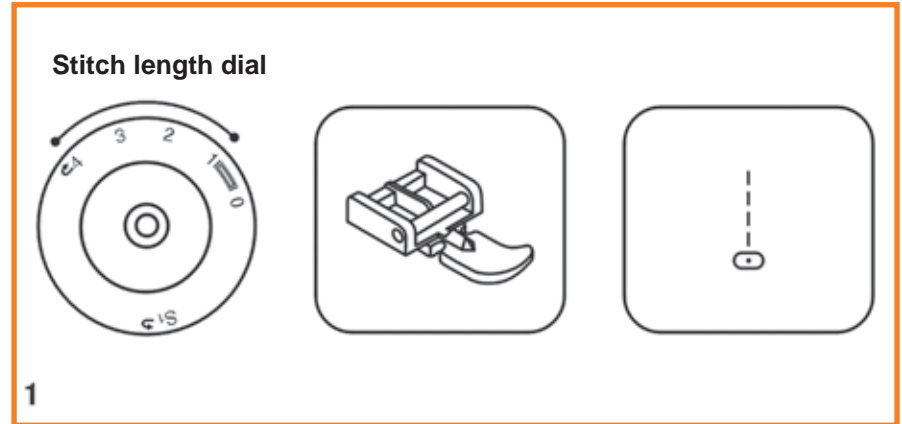

3-STEP ZIG-ZAG

Sewing on lace and elastic, darning, mending, finishing edges.

Set the machine as illustrated. (1)

Patching:

Place the patch in position and stitch around edges.

The stitch length can be shortened to produce very close stitches.
(A)

When mending tears, it is advisable to use a piece of backing fabric to reinforce. The stitch density can be varied by adjusting the stitch length. Begin by sewing over the center and then overlap on both sides. Depending on the type of fabric and damage, sew between 3 and 5 rows. (B)

To finish edges, stitch along the edge of the fabric.

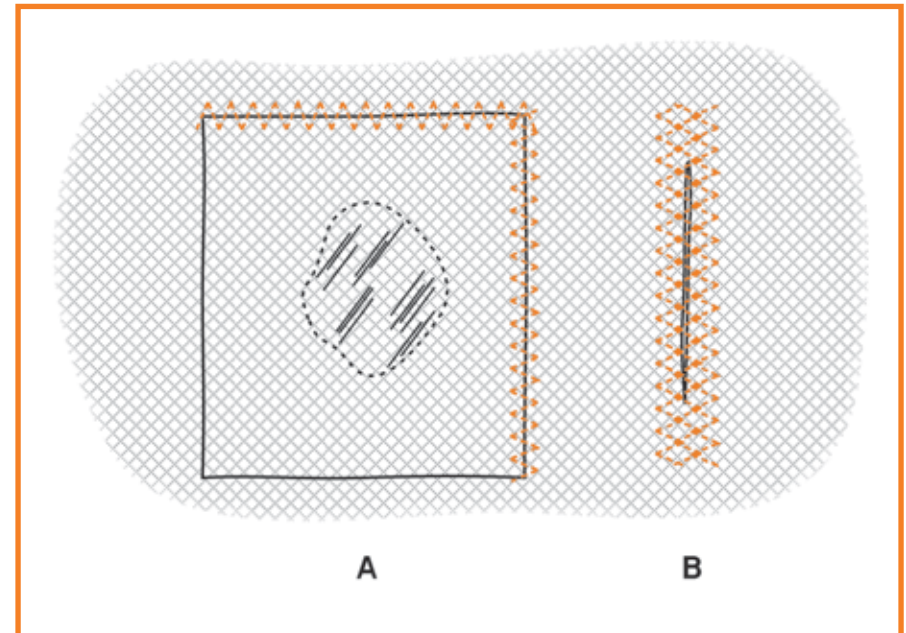
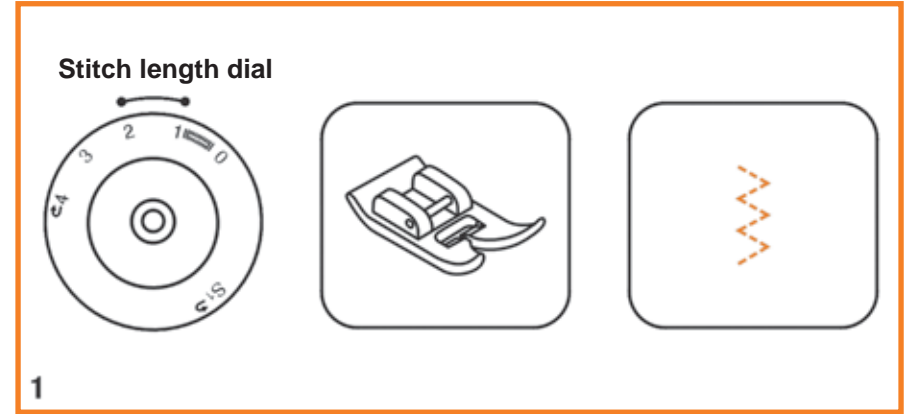

STITCH SELECTION

Triple straight stitch: (1)

For reinforced seams.

Turn the stitch length dial to "S1".

The machine sews two stitches forwards and one stitch backwards.

This gives triple reinforcement.

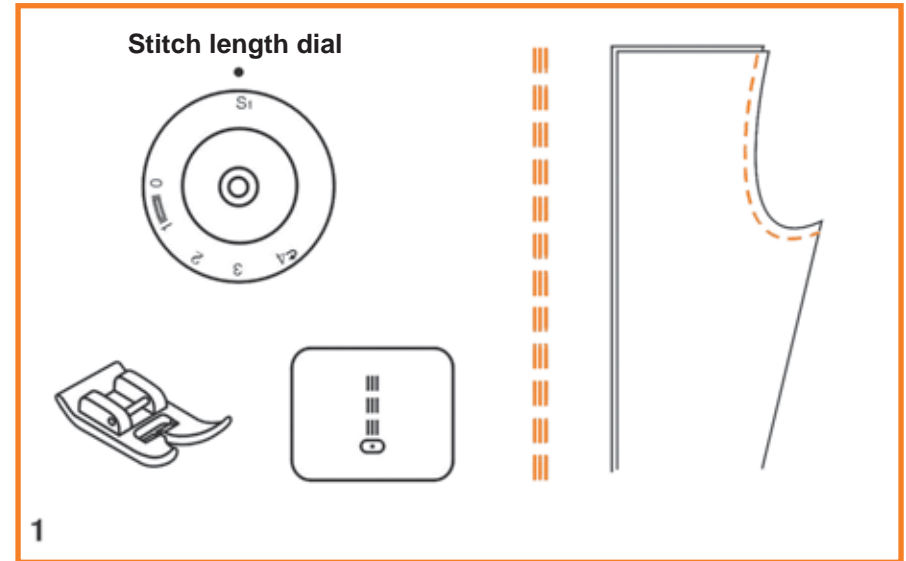

Triple zig-zag: (2)

For hardwearing seams, hems and decorative seams.

Turn the stitch length dial to "S1".

Triple zig-zag is suitable for firm fabrics like denim, corduroy, etc.

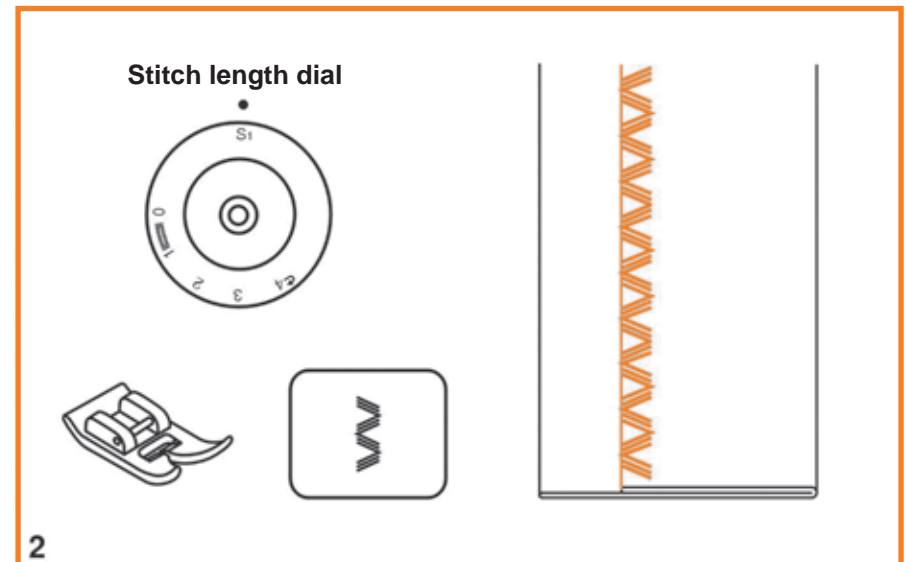

MAINTENANCE

Attention:

Disconnect the machine from the electricity supply by removing the plug from the main socket. When cleaning the machine, it must always be disconnected from the electricity supply.

Remove the stitch plate

Turn the handwheel until the needle is fully raised. Open the hinged front cover and unscrew the needle plate screw with the screw driver.(1)

Cleaning the feed dog

Remove the bobbin case and use the brush supplied to clean the whole area.(2)

Cleaning and lubricating the hook (3)

Remove the bobbin case. Snap the two hook retaining arms (a) outwards. Remove the hook race cover (b) and the hook (c) and clean with a soft cloth. Lubricate at the points (d) (1-2 drops) with sewing machine oil. Turn the handwheel until the hook race (e) is in the left position. Replace the hook (c). Replace the hook race cover and snap back the two hook retaining arms. Insert the bobbin case and bobbin and replace the stitch plate.

Important:

Fabric lint and threads must be removed regularly.

Your machine should be serviced at regular intervals at your local dealer.

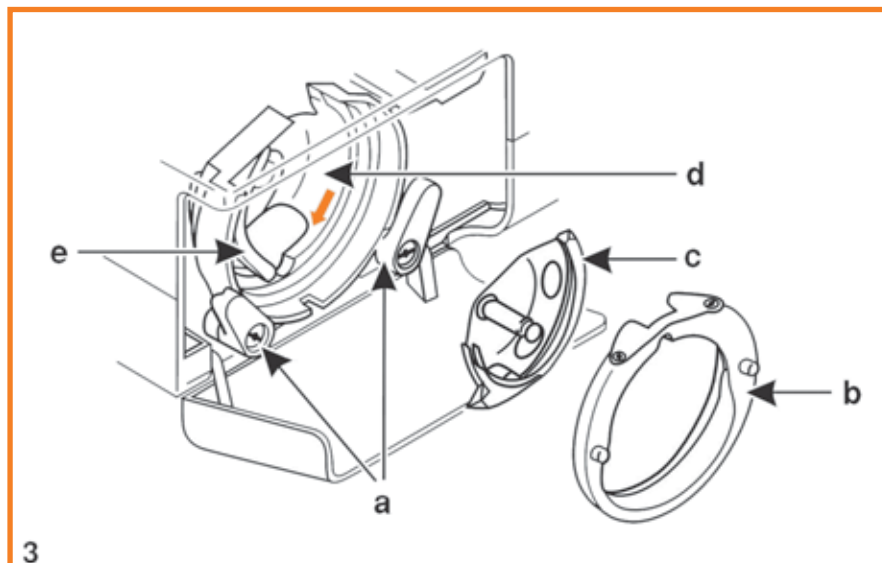
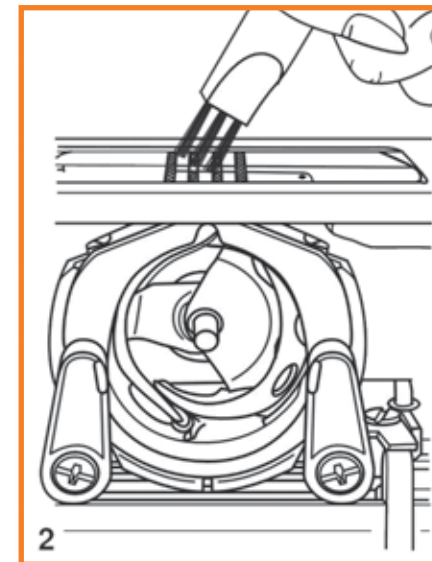

TROUBLE SHOOTING GUIDE

Problem	Cause	Correction
Upper thread breaks	<ol style="list-style-type: none"> 1. The machine is not threaded correctly. 2. The thread tension is too tight. 3. The thread is too thick for the needle. 4. The needle is not inserted correctly. 5. The thread is wound around the spool holder pin. 6. The needle is damaged. 	<ol style="list-style-type: none"> 1. Rethread the machine. 2. Reduce the thread tension. (lower number) 3. Select a larger needle. 4. Remove and reinsert the needle. (flat side towards the back) 5. Remove the spool and wind thread onto spool. 6. Replace the needle.
Lower thread breaks	<ol style="list-style-type: none"> 1. The bobbin case is not inserted correctly. 2. The bobbin case is threaded wrong. 3. The lower thread tension is too tight. 	<ol style="list-style-type: none"> 1. Remove and reinsert the bobbin case and pull on the thread. The thread should pull easily. 2. Check both bobbin and bobbin case. 3. Loosen lower thread tension as described.
Skipped stitches	<ol style="list-style-type: none"> 1. The needle is not inserted correctly. 2. The needle is damaged. 3. The wrong size or type of needle has been used. 4. The foot is not attached correctly. 	<ol style="list-style-type: none"> 1. Remove and reinsert needle. (flat side towards the back) 2. Insert a new needle. 3. Choose a needle to suit the thread and fabric. 4. Check and attach correctly.
Needle breaks	<ol style="list-style-type: none"> 1. The needle is damaged. 2. The needle is not correctly inserted. 3. Wrong needle size for the fabric. 4. The wrong foot is attached. 	<ol style="list-style-type: none"> 1. Insert a new needle 2. Insert the needle correctly. (flat side towards the back) 3. Choose a needle to suit the thread and fabric. 4. Select the correct foot.
Loose stitches	<ol style="list-style-type: none"> 1. The machine is not correctly threaded. 2. The bobbin case is not correctly threaded. 3. Needle/ fabric/ thread combination is wrong. 4. Thread tension wrong. 	<ol style="list-style-type: none"> 1. Check the threading. 2. Thread the bobbin case as illustrated. 3. The needle size must suit the fabric and thread. 4. Correct the thread tension.
Seams gather or pucker	<ol style="list-style-type: none"> 1. The needle is too thick for the fabric. 2. The stitch length is incorrectly adjusted. 3. The thread tension is too tight. 	<ol style="list-style-type: none"> 1. Select a finer needle. 2. Shorten the stitch length. 3. Loosen the thread tension.
Uneven stitches, uneven feed	<ol style="list-style-type: none"> 1. Poor quality thread. 2. The bobbin case is incorrectly threaded. 3. Fabric has been pulled. 	<ol style="list-style-type: none"> 1. Select a better quality thread. 2. Remove bobbin case, thread and insert correctly. 3. Do not pull on the fabric while sewing, let it be moved up by the feed dogs.
The machine is noisy	<ol style="list-style-type: none"> 1. The machine must be lubricated. 2. Lint or oil have collected on the hook or needle bar. 3. Poor quality oil has been used. 4. The needle is damaged. 	<ol style="list-style-type: none"> 1. Lubricate as described. 2. Clean the hook and feed dog as described. 3. Only use good quality sewing machine oil. 4. Replace the needle.
The machine jams	Thread is caught in the hook.	Remove the upper thread and bobbin case, turn the handwheel backwards and forwards by hand and remove the thread. Lubricate as described.



Please note that on disposal, this product must be safely recycled in accordance with relevant National legislation relating to electrical/electronic products.
If in doubt please contact your retailer for guidance

