

HuskyStar™
BY HUSQVARNA VIKING



USER'S GUIDE

E20

This household sewing machine is designed to comply with IEC/EN 60335-2-28 and UL1594

IMPORTANT SAFETY INSTRUCTIONS

When using an electrical appliance, basic safety precautions should always be followed, including the following:

Read all instructions before using this household sewing machine.

DANGER - To reduce the risk of electric shock:

- A sewing machine should never be left unattended when plugged in. Always unplug this sewing machine from the electric outlet immediately after using and before cleaning.
- Always unplug before relamping. Replace bulb with same type rated 10 Watt (110-120V), 15 Watt (220-240V).

WARNING - To reduce the risk of burns, fire, electric shock, or injury to persons:

- Do not allow to be used as a toy. Close attention is necessary when this sewing machine is used by or near children and infirm persons.
- Use this sewing machine only for its intended use as described in this manual. Use only attachments recommended by the manufacturer as contained in this manual.
- Never operate this sewing machine if it has a damaged cord or plug, if it is not working properly, if it has been dropped or damaged, or dropped into water. Return the sewing machine to the nearest authorized dealer or service center for examination, repair, electrical or mechanical adjustment.
- Never operate the sewing machine with any air openings blocked. Keep ventilation openings of the sewing machine and foot controller free from the accumulation of lint, dust, and loose cloth.
- Keep fingers away from all moving parts. Special care is required around the sewing machine needle.
- Always use the proper needle plate. The wrong plate can cause the needle to break.
- Do not use bent needles.
- Do not pull or push fabric while stitching. It may deflect the needle causing it to break.
- Switch the sewing machine off ("0") when making any adjustment in the needle area, such as threading needle, changing needle, threading bobbin, or changing presser foot, etc.
- Always unplug sewing machine from the electrical outlet when removing covers, lubricating, or when making any other user servicing adjustments mentioned in the instruction manual.
- Never drop or insert any object into any opening.
- Do not use outdoors.
- Do not operate where aerosol (spray) products are being used or where oxygen is being administered.
- To disconnect, turn all controls to the off ("0") position, then remove plug from outlet.
- Do not unplug by pulling on cord. To unplug, grasp the plug, not the cord.

SAVE THESE INSTRUCTIONS

CONTENTS

PRINCIPAL PARTS	4
ACCESSORIES	6
SLIDE ON THE SNAP-IN ACCESSORY BOX	7
CONNECTING THE MACHINE TO POWER SOURCE	8
CHANGING THE BULB	9
TWO-STEP PRESSER FOOT LEVER	10
ADJUSTING THE PRESSER FOOT PRESSURE	10
PRESSER FOOT SHANK	11
WINDING THE BOBBIN	12
INSERTING THE BOBBIN	13
CHANGING THE NEEDLE (SYSTEM 130/705H)	14
THREADING THE UPPER THREAD	15
BRINGING UP THE BOBBIN THREAD	16
THREAD TENSION	17
RAISE OR LOWER THE FEED DOG	18
REVERSE SEWING	19
CHANGING SEWING DIRECTIONS	19
REMOVING THE FABRIC	19
CUTTING THE THREAD	19
HOW TO CHOOSE YOUR PATTERN	20
MATCHING NEEDLE / FABRIC / THREAD	21
ZIG ZAG SEWING	22
STRAIGHT STITCHING AND NEEDLE POSITION	23
OVERLOCK STITCHES	24
BLIND HEM	25
ONE STEP BUTTONHOLES	26
LEFT AND RIGHT SIDE BALANCE FOR BUTTONHOLE	27
ZIPPERS AND PIPING	28
3-STEP ZIG-ZAG	29
STRETCH STITCH SELECTION	30
FREE MOTION DARNING	31
DARNING	32
QUILTING	33
MAINTENANCE	34
TROUBLESHOOTING GUIDE	35

PRINCIPAL PARTS

1. Thread tension dial
2. Presser foot pressure
3. Thread take-up lever
4. Thread cutter
5. Presser foot
6. Needle plate
7. Accessory box
8. Bobbin stopper
9. Stitch length dial
10. Stitch width dial
11. Stitch display
12. Reverse sewing lever
13. Feed dog adjustment lever
14. One step buttonhole lever

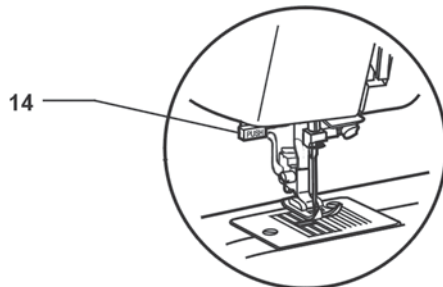
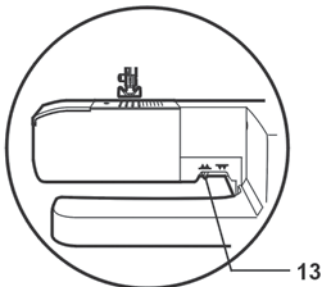
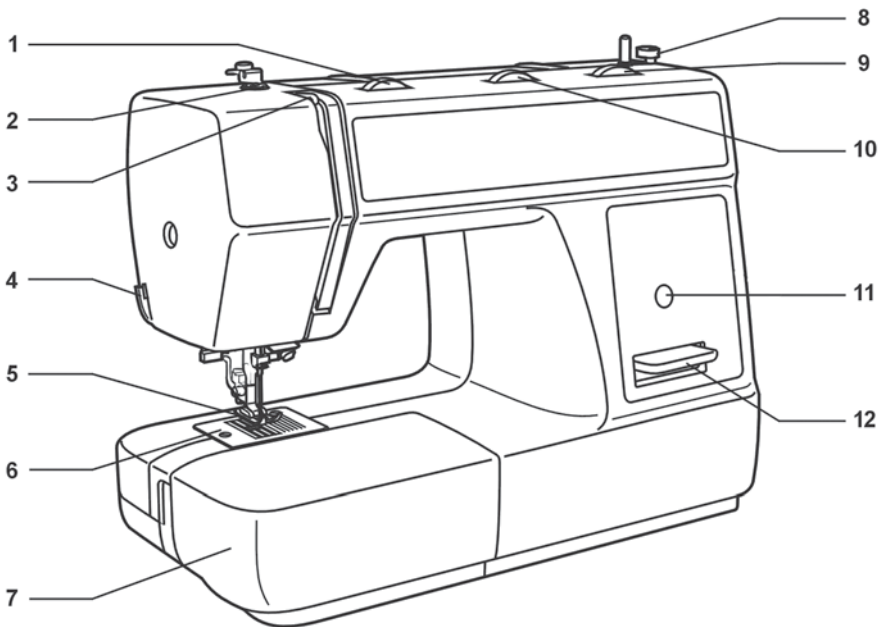

-
15. Handle
 16. Bobbin winder
 17. Spool pin
 18. Handwheel
 19. Pattern selector dial
 20. Power switch
 21. Main plug socket
 22. Bobbin thread guide
 23. Upper thread guide
 24. Presser foot lever
 25. Buttonhole stitch balance adjustment slot

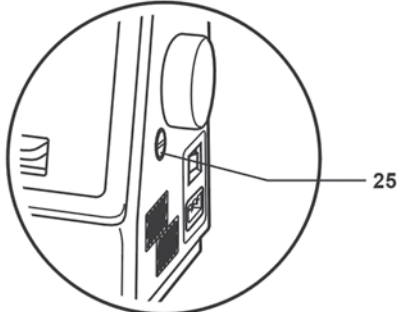
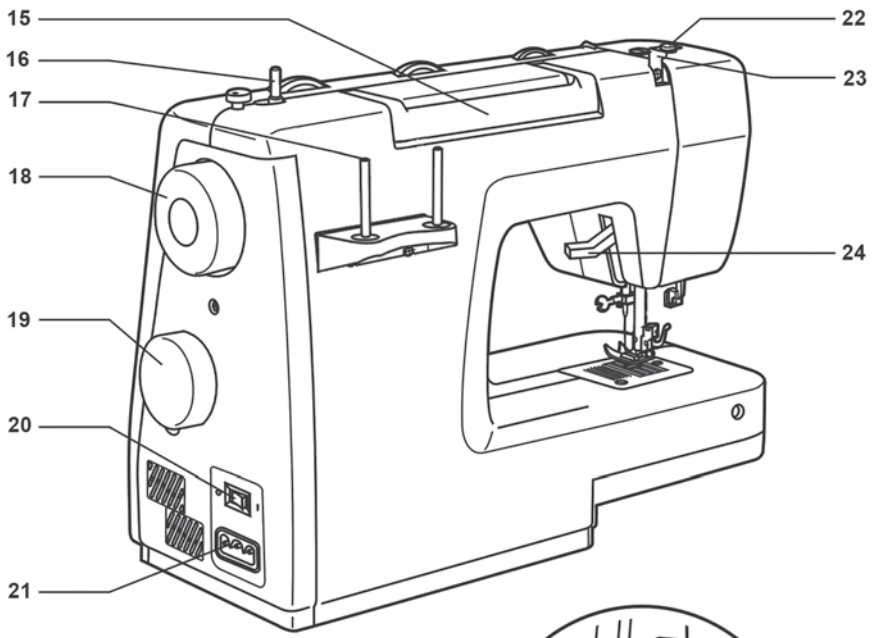

ACCESSORIES

1. All purpose foot
2. Zipper foot
3. Satin stitch foot
4. Buttonhole foot
5. Quilting foot
6. Free-Motion/Darning foot
7. Blind hem foot
8. L-screwdriver
9. Seam ripper/ brush
10. Oil bottle
11. Pack of needles
12. Bobbins
13. Seam guide
14. Spool pin felt (2x)

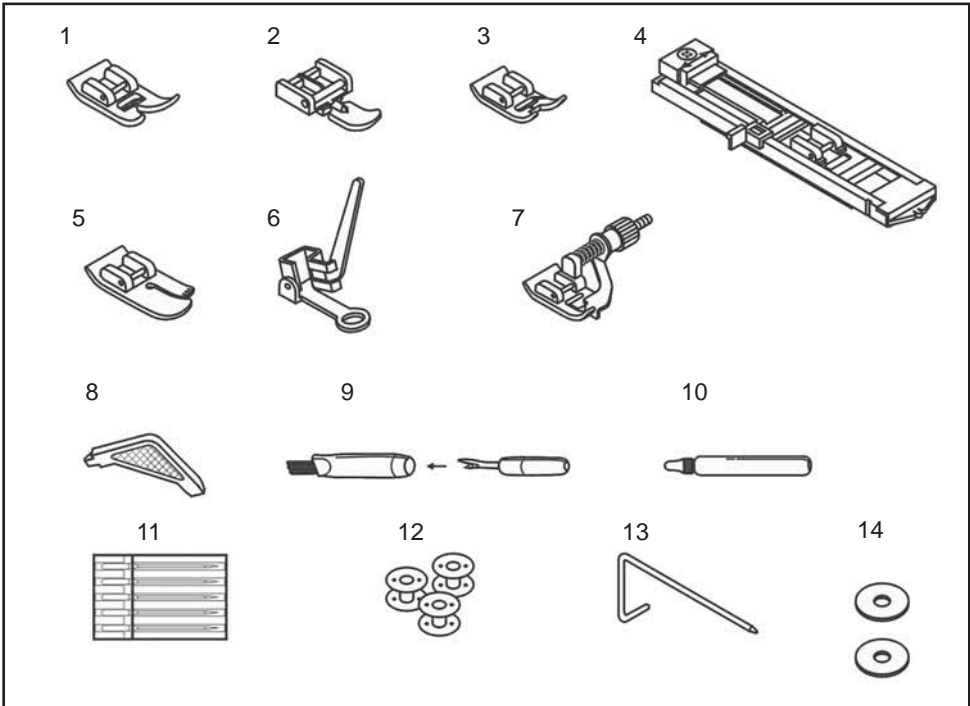

SLIDE ON THE SNAP-IN ACCESSORY BOX



Hold the snap-in accessory box horizontal, and push it in the direction of the arrow. (1)

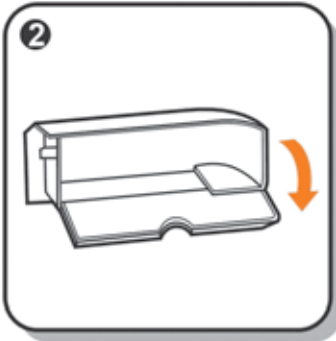

To open, lift up at the point of the arrow. (2)

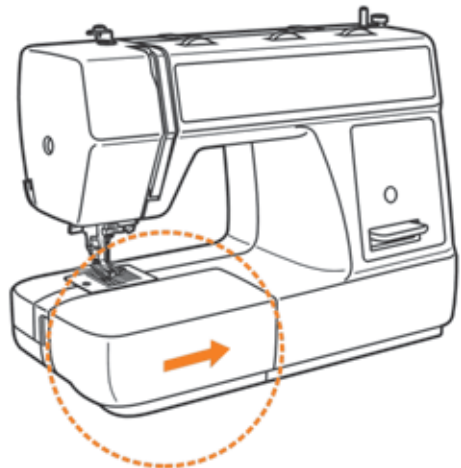

CONNECTING THE MACHINE TO POWER SOURCE

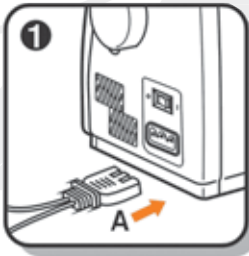

Caution: Always make sure that the machine is unplugged from power source and the main switch is on "O". when the machine is not in use and before inserting or removing parts.

- Connect the machine to a power source as illustrated (1/2).
- The power switch is located above the socket. Your machine will not operate unless this switch is on "I". (1)
- Sewing light turns on automatically when the main switch is on "I".
- To start the machine, press on the foot control (3). The speed of the machine is regulated by the amount of pressure put on the foot control.

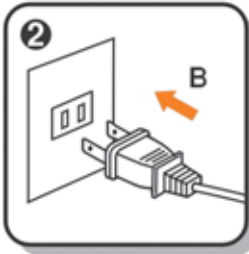

Attention: Consult a qualified electrician if in doubt as to connect machine to power source. Unplug power cord when machine is not in use.

The appliance must be used with the foot controller:

- For USA and Canada, 110-120V: 4C-316B
- For Australia, 240V: 4C-326G
- For Europe, 220-240V: 4C-316C or 4C-326C

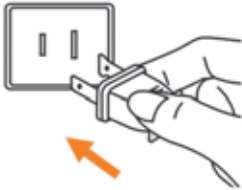

For the USA and Canada

This appliance has a polarized plug (one blade wider than the other), to reduce the risk of electrical shock; this plug will fit in a polarized outlet only one way. If the plug does not fit fully in the outlet, reverse the plug. If it still does not fit, contact a qualified electrician. Do not modify the plug in any way.

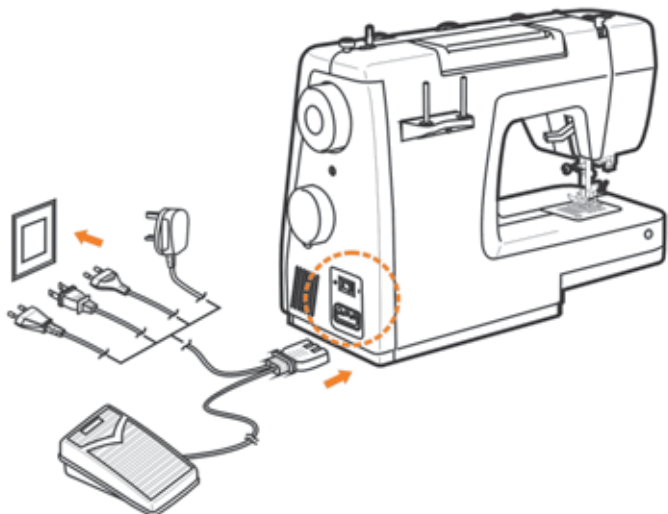

CHANGING THE BULB

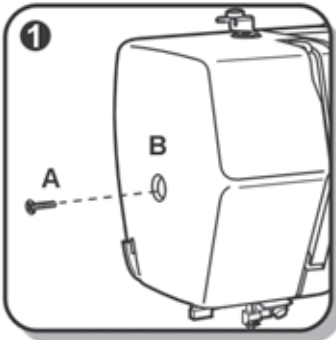

Caution: Make sure to disconnect the electrical supply plug from wall outlet before changing light bulb.

Replace bulb with same type rated:

10 watts (110-120V)

15 watts (220-240V)

- Loosen screw (A) as illustrated. (1)
- Remove the cover (B).
- Unscrew the bulb and put in a new one (C). (2)
- Replace the cover and tighten screw.

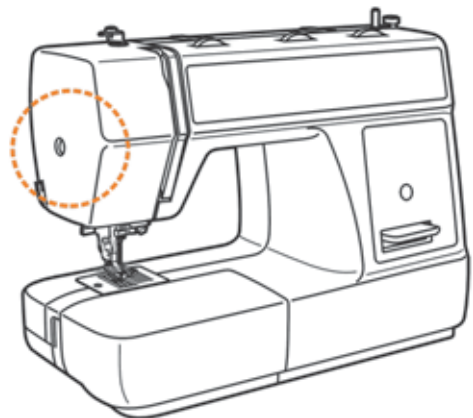
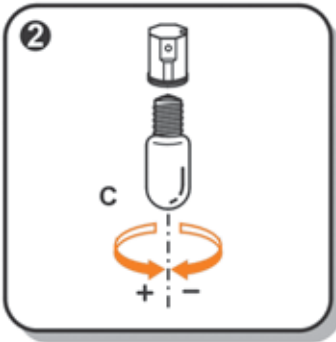

TWO-STEP PRESSER FOOT LEVER

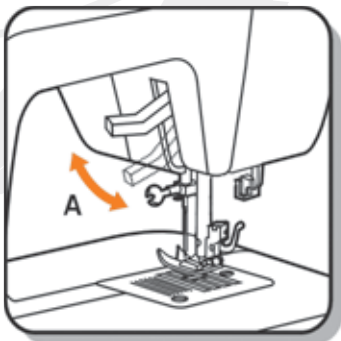

When sewing several layers or thick fabrics, the presser foot can be raised a second stage for easy positioning of the work. (A)

ADJUSTING THE PRESSER FOOT PRESSURE



The presser foot pressure of the machine has been pre-set and usually requires no readjustment for most fabrics (light-or-heavy weight).

However, if you need to adjust the presser foot pressure, turn the presser adjusting screw with a coin.

For sewing very thin fabric, loosen the pressure by turning the screw counter clockwise for less pressure on the fabric, and for heavy fabric, tighten by turning it clockwise for more pressure on the fabric.

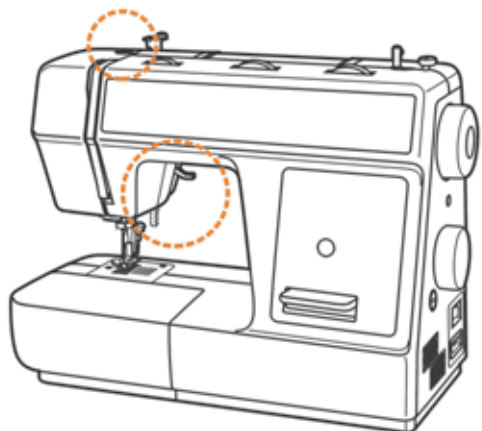

PRESSER FOOT SHANK

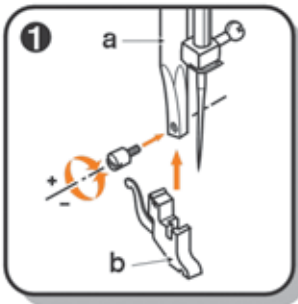

Attention: Turn power switch to “O” before carrying out any of the operations below.

Attaching the presser foot shank:

Raise the needle to its highest position and raise the presser foot lever. Attach the presser foot shank (b) to the presser foot bar (a). (1)

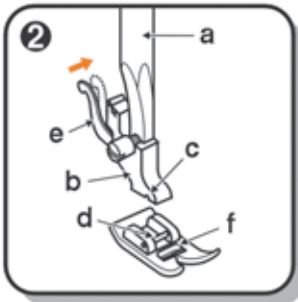

Attaching the presser foot:

Lower the presser foot shank (b) until the cut-out (c) is directly above the pin (d). (2)

Lower the presser foot shank (b) and the presser foot (f) will engage automatically.



Removing the presser foot:

Raise the presser foot.

Release the pressure foot by raising lever (e) located at the back of the presser foot shank. (3)

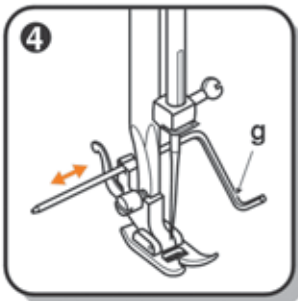

Attaching the seam guide:

Attach the seam guide (g) in the slot on the shank as illustrated. Adjust the distance as required for hems, pleats, quilting, etc. (4)

WINDING THE BOBBIN

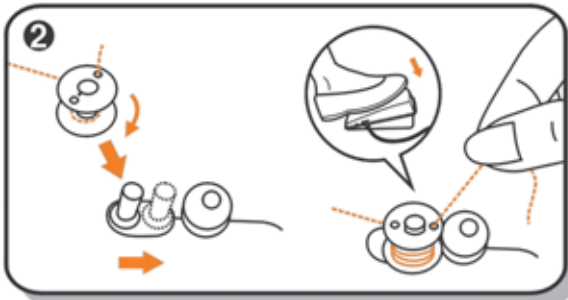
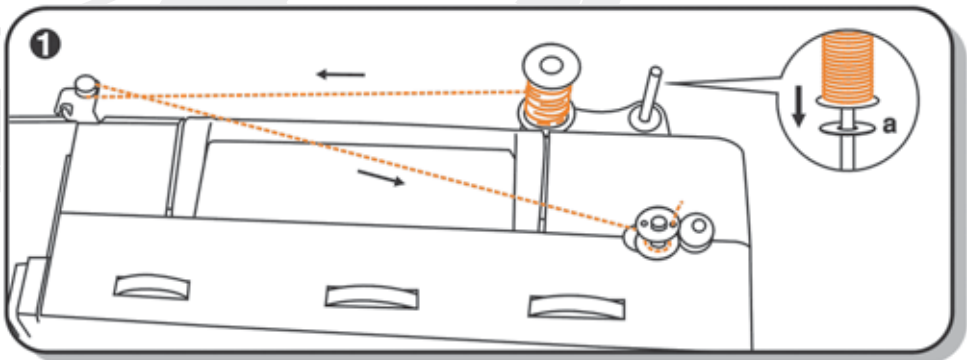

Place spool on spool pin with spool pin felt underneath (a).

Take the thread from the spool around the bobbin winder tension disc clockwise. (1)

Thread bobbin as illustrated and place it on the spindle. Push the bobbin to the right towards the bobbin winding position. (2)

Press the foot control gently to wind the bobbin. The bobbin will stop winding when it is full. Push the bobbin to the left to “sewing position” and remove it.



Please Note: When the bobbin winder spindle is in “bobbin winding” position, the machine will not sew and the hand wheel will not turn. To start sewing, push the bobbin winder spindle to the left (sewing position).

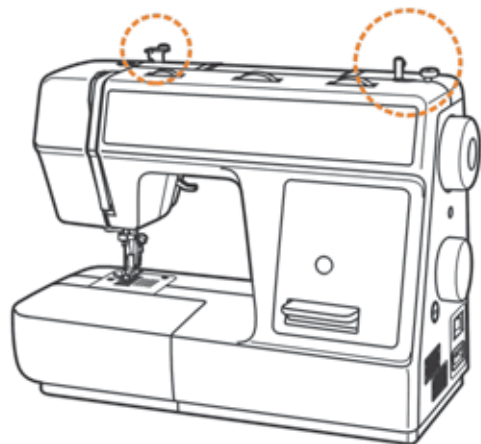

INSERTING THE BOBBIN

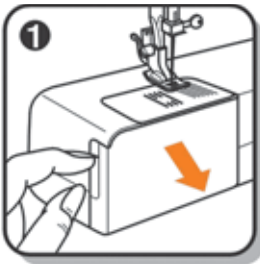

Attention: Turn power switch to “O” before inserting or removing the bobbin.

When inserting or removing the bobbin, the needle must be fully raised.

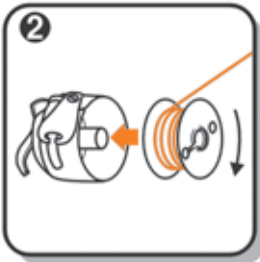

- Open the hinged cover. (1)
- Hold the bobbin case with one hand. Insert the bobbin so that the bobbin runs in a clockwise direction (arrow). (2)
- Pull the thread through the slot, down and to the left until it enters the delivery eyelet (rectangular opening) under the tension spring. (3)
- Hold the bobbin case by the hinged latch. (4)
- Insert the bobbin case fully into the shuttle race and release the latch. Make sure that the metal finger fits into the notch at the top of the race cover. (5) Push on the bobbin case to be sure it is clicked in completely.

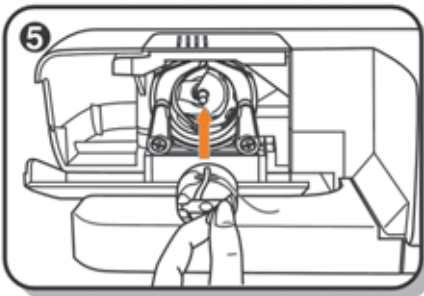
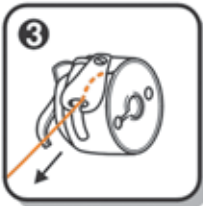

CHANGING THE NEEDLE (SYSTEM 130/705H)

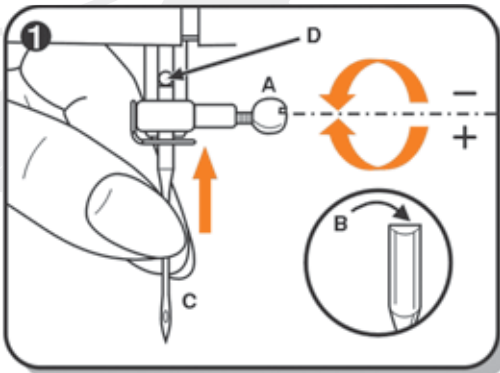

Caution: Turn power switch to “O” before inserting or removing the needle.

Replace the needle at the first sign of thread breakage or skipped stitches. Select the correct type and size of needle for the fabric to be sewn. Turn the hand wheel towards you until the needle is at highest position. Loosen the needle clamp screw (A) and tighten again after inserting the new needle. (1)

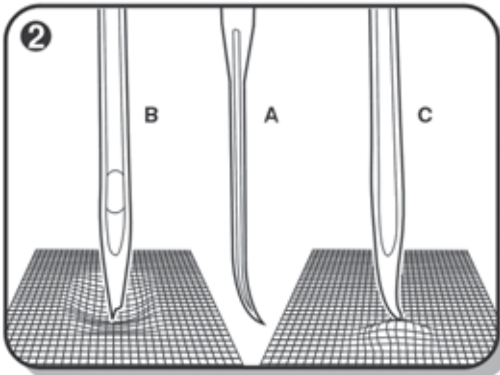

The flat side of the needle shaft should be facing toward the back (B).

Push the needle up (C) into the needle clamp as far as it will go (D).

Tighten the needle clamp screw firmly.

The sewing needle must always be straight and sharp for smooth sewing. Replace the needle (2) if it is bent (A), blunt (C) or the point is damaged (B).

THREADING THE UPPER THREAD

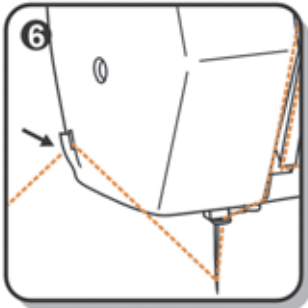
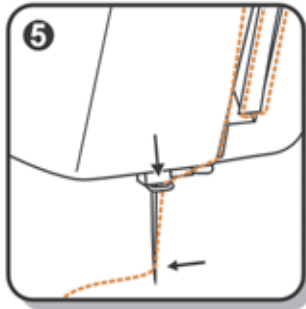
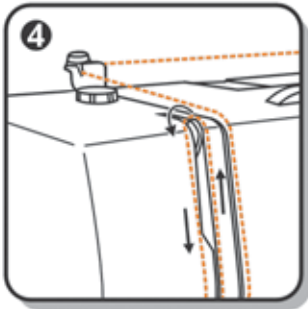
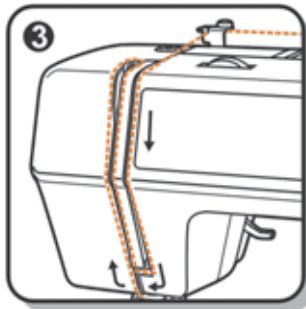
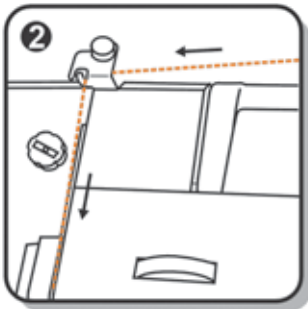

⚠ Caution: Before threading, turn power switch to "0".

Raise the needle bar to its highest position. Follow exactly the numbered threading sequence illustrated below. If you skip a step or fail to properly engage the thread in any of the thread guides, the machine will not sew properly. (1-5)

1. Place spool on spool pin with felt underneath.
2. Bring thread to the left behind and around first thread guide.
3. Bring the thread down into the right slot, under the guide and up in left slot.
4. Bring thread over and

forward into the take-up lever.

5. Slide thread into wire guide above the needle.

6. Thread the needle from front to back. Leave about 10 cm (4") of thread loose behind the needle. (6)

Bring the thread under the presser foot and up into the thread cutter.



a. Spool pin felt

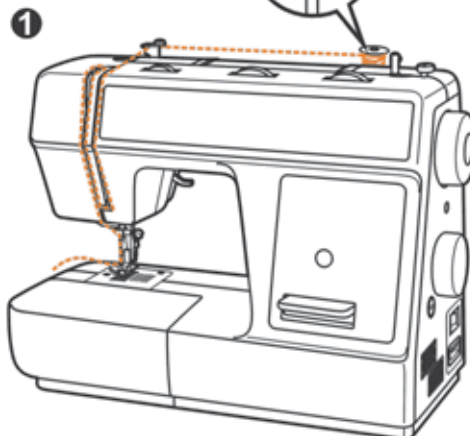

BRINGING UP THE BOBBIN THREAD

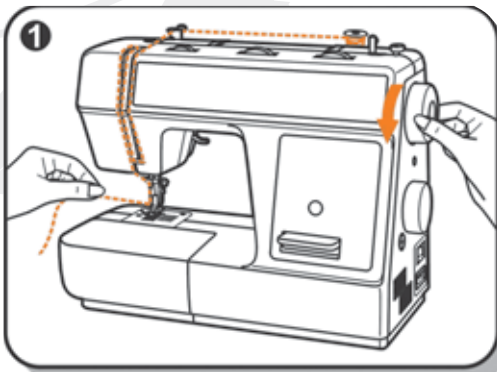

Hold the upper thread with your left hand. Turn the handwheel towards you with your right hand until the needle goes down and comes up again to the highest position. (1)

- Pull the upper thread to bring up the bobbin thread. The upper thread should have caught the bobbin thread in a loop.
- Pull the needle thread toward you and the bobbin thread will come up from the bobbin in a large loop. (2) Pull about 15 cm. (6") of both threads away from you under the presser foot.

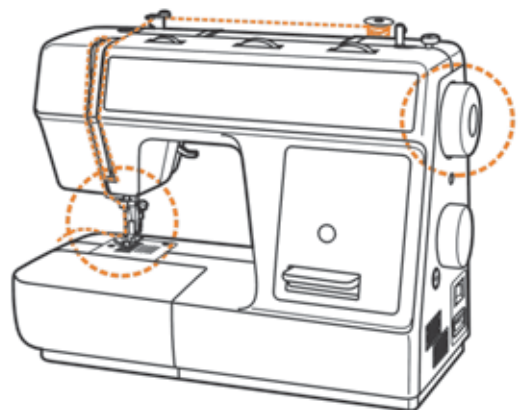
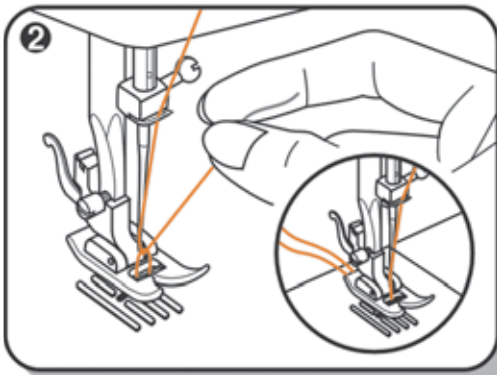

THREAD TENSION

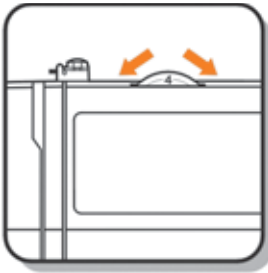

Upper thread tension

Basic thread tension setting: "4".

To increase the tension, turn the dial up to a higher number.

To reduce the tension, turn the dial to a lower number.

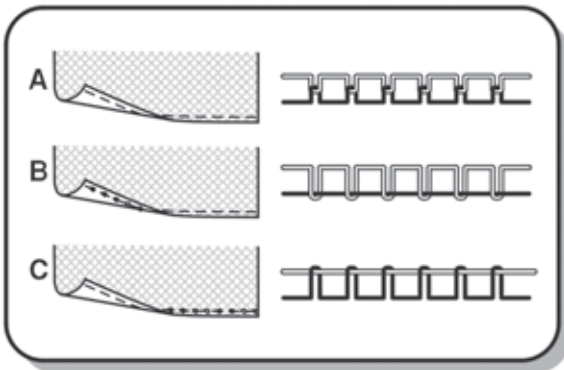

- A. Normal thread tension - upper and bobbin thread join in fabric.
- B. Thread tension too loose - upper thread "loops" on underside of fabric.
- C. Thread tension too tight - bobbin thread "loops" on top side of fabrics.

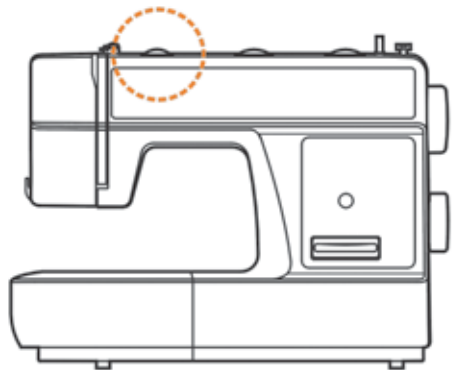

RAISE OR LOWER THE FEED DOG



For normal sewing, keep the feed dog up. For free-motion embroidery, sewing on buttons and darning, lower the feed dog.

1. Remove the accessory tray.
2. Move the drop feed lever to (b) ▼▼ to lower the feed dog.

To raise the feed dog move the lever to (a) ▲▲.
The feed dog will come up when you start to sew.

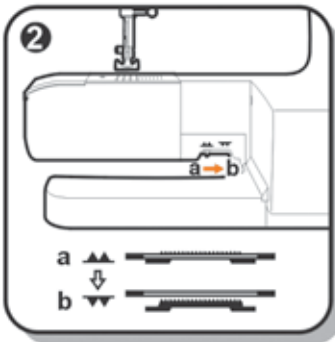

REVERSE SEWING



Reverse sewing is used for locking the end of seams and where reinforcement is needed. At the end of seam, press down the reverse sewing lever and touch the foot control lightly. Sew a few reverse stitches. Release the lever and the machine will sew forward again (A).

CHANGING SEWING DIRECTIONS

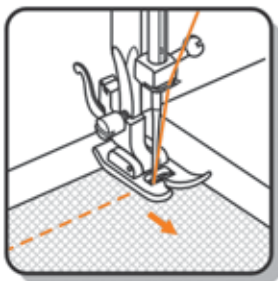

1. Stop the machine at the point where you wish to change directions with the needle in the fabric.
2. Raise the presser foot and turn the fabric using the needle as a turning point.
3. Lower the presser foot and start sewing in the new direction.

REMOVING THE FABRIC

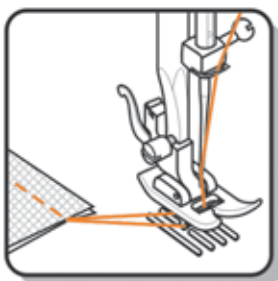

Turn the handwheel towards you to bring the thread take up lever to its highest position. Raise the presser foot and draw the fabric away from you.

CUTTING THE THREAD



Hold the threads behind the presser foot. Using both hands, guide them to the slit at the rear of the presser bar and press down to cut the thread. You can also use the thread cutter on the side of the machine (B).

HOW TO CHOOSE YOUR PATTERN

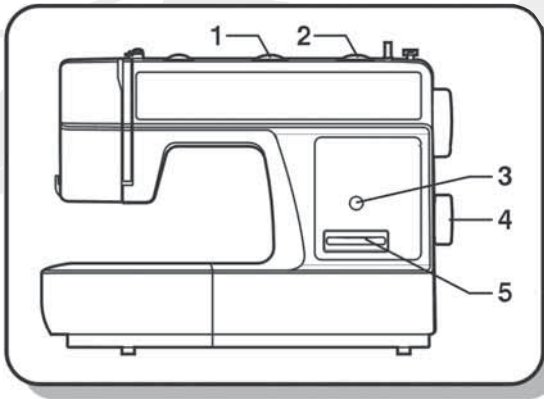

1. Stitch width dial
2. Stitch length dial
3. Stitch display
4. Pattern selector dial
5. Reverse sewing lever

For straight stitch select pattern “A” with pattern selector dial (4). Adjust the stitch length with the stitch length dial (2). You may choose any needle position, by turning the stitch width dial (1).

For zigzag stitch, select pattern “B” with pattern selector dial (4). Adjust the stitch length (2) and stitch width (1) according to the fabric being used.

To obtain any of the other patterns shown in the left row on the stitch selection panel, select the letter below the stitch with the pattern selector dial. Adjust the stitch length and the stitch width with the control dials according to the result desired.

To obtain any of the patterns on the right row, turn the stitch length dial to “S”, select the pattern desired with pattern selector dial, and adjust the stitch width with the stitch width dial.

MATCHING NEEDLE / FABRIC / THREAD

Needle, fabric, thread selection guide

NEEDLE SIZE	FABRICS	THREAD
9-11(65-75)	Lightweight fabrics-thin cottons, voile, silk, muslin, interlocks, cotton knits, tricot, jerseys, crepes, woven polyester, shirt & blouse fabrics.	Light-duty thread in cotton, nylon or polyester.
12(80)	Medium weight fabrics-cotton, satin, kettleclote, sailcloth, double knits, lightweight woollens.	Most threads sold are medium size and suitable for these fabrics and needle sizes. Use polyester threads on synthetic materials and cotton on natural fabrics for best results. Always use the same thread on top and bottom.
14(90)	Medium weight fabrics-cotton duck, woolen, heavier knits, terrycloth, denims.	
16(100)	Heavyweight fabrics-canvas, woolens, outdoor tent and quilted fabrics, denims, upholstery material (light to medium).	
18(110)	Heavy woollens, overcoat fabrics, upholstery fabrics, some leathers and vinyls.	Heavy duty thread, carpet thread. (Use heavy foot pressure-large numbers.)

Important: Match needle size to thread size and weight of fabric.

NEEDLES	EXPLANATION	TYPE OF FABRIC
HA×1 15×1	Standard sharp needles. Sizes range thin to large. 9 (65) to 18 (110)	Natural woven fabrics-wool, cotton, silk, etc. Not recommended for double knits.
15×1/705H (SIN)	Semi-ball point needle, scarfed. 9 (65) to 18 (110)	Natural and synthetic woven fabrics, polyester blends. Knits-polyesters, interlocks, tricot, single and double knits. Can be used instead of 15×1 for sewing all fabrics.
15×1/705HS (SUK)	Full ball point needle 9 (65) to 18 (110)	Sweater knits, Lycra, swimsuit fabric, elastic.
130 PCL	Leather needles. 12 (80) to 18 (110)	Leather, vinyl, upholstery. (Leaves smaller hole than standard large needle.)



Note:

1. Twin needles, can be purchased for topstitching and decorative sewing.
2. When sewing with twin needles, the stitch width dial should be set at less than "2.5".
3. European needles show sizes 65, 70, 80 etc. American and Japanese needles show size 9, 11, 12 etc.
4. Replace needle often (approximately every other garment) and / or at first thread breakage or skipped stitches.

ZIG ZAG SEWING

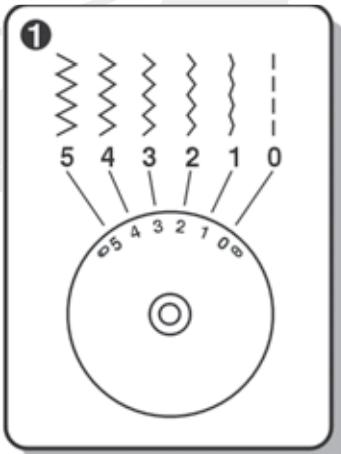

Turn the pattern selector dial to “B”.

Function of stitch width dial

The maximum zigzag stitch width for zigzag stitching is “5”; however, the width can be reduced on any pattern. The width increases as you move zigzag dial from “0” - “5”. For twin needle sewing, never set the width wider than “2.5”. (1)

Function of stitch length dial while zigzagging

The density of zigzag stitches increase as the setting of stitch length dial approaches “0”. Most zigzag stitches are sewn at “2.5” or below. (2)

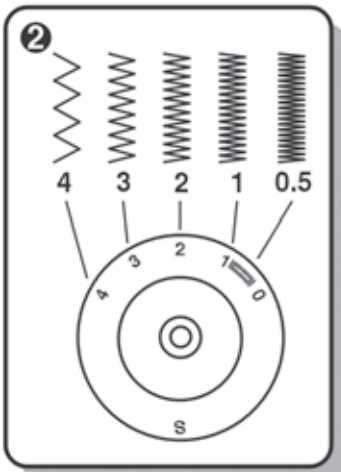

Satin stitch

When the stitch length is set between “0” - “1”, the stitches are very close together producing the “satin stitch” which is used for making buttonholes and decorative stitches.

Sewing thin fabrics

When sewing very thin fabrics, it is suggested that you use stabilizer on the wrong side of the fabric.

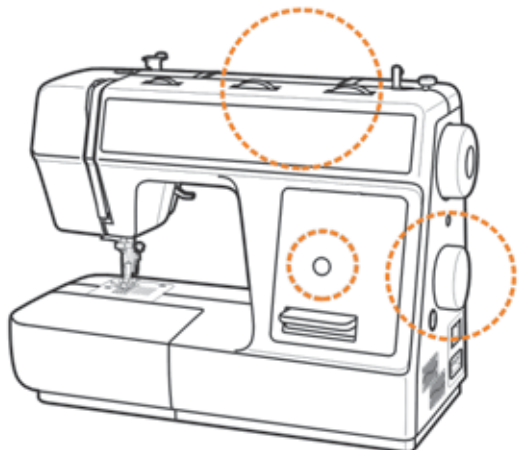
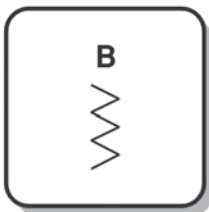

STRAIGHT STITCHING AND NEEDLE POSITION

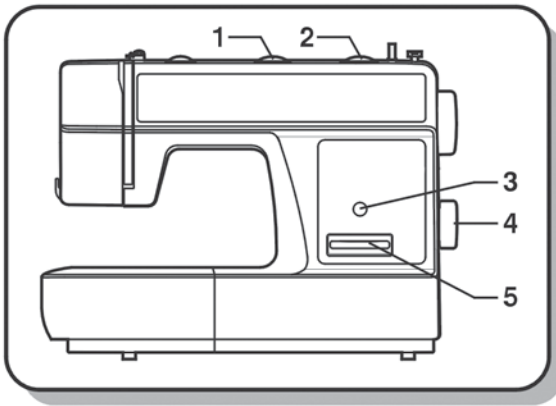

1. Stitch width dial
2. Stitch length dial
3. Stitch display
4. Pattern selector dial
5. Reverse sewing lever

Turn the pattern selector dial so that the stitch display shows the straight stitch position (A).

Generally speaking, the thicker the fabric, thread and needle, the longer the stitch should be.

Choose your needle position, from center position to left needle position by changing the stitch width dial (1) from "0" to "5".



OVERLOCK STITCHES



Seams, overcasting, visible hems.

Turn the stitch length dial to “3” or “S”.
The stitch width can be adjusted to suit the fabric.

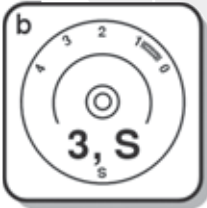

Double overlock stitch: 

Set stitch length to S.
For fine knits, handknits, seams. (1)

Standard overlock: 

Set stitch length to S.
For fine knits, jerseys, neck edges, ribbing. (2)

Stretch overlock: 

Set stitch length to S.
For fine knits, jerseys, neck edges, ribbing. (3)
All overlock stitches are suitable for sewing and finishing/
overcasting edges in one step.

When overcasting, the needle should just go over the edge of the fabric.



Attention: Use new needles or ball point needles or stretch needles!

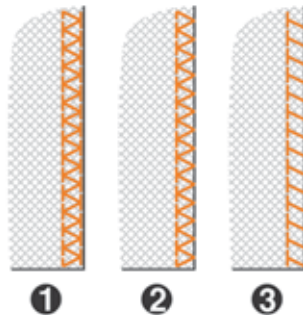

BLIND HEM



For hems in curtains, trousers, skirts, etc.

..... Blind hem for woven fabrics. Position “C” on selection dial.

..... Blind hem for stretch fabrics. Position “D” on selection dial.

Set the machine as illustrated.

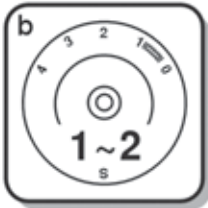

Note: It takes practice to sew blind hems. Always make a test on scraps.

Fold the fabric as illustrated with the wrong side up. (1)

Place the fabric under the foot. Turn the handwheel towards you by hand until the needle swings fully to the left. It should just pierce the fold of the fabric. If it does not, adjust the stitch width accordingly. (2) Adjust the guide (3) by turning the knob (4) so that the guide just rests against the fold. Sew slowly, by pressing the foot control lightly. Guide the fabric along the edge of the guide.

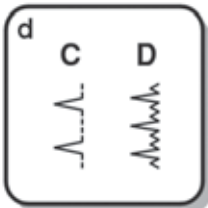

- a. Stitch width
- b. Stitch length
- c. Presser foot
- d. Stitch pattern

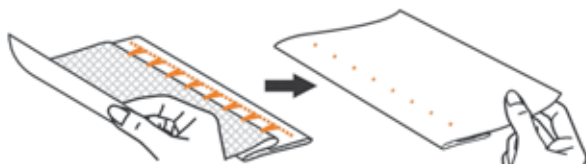
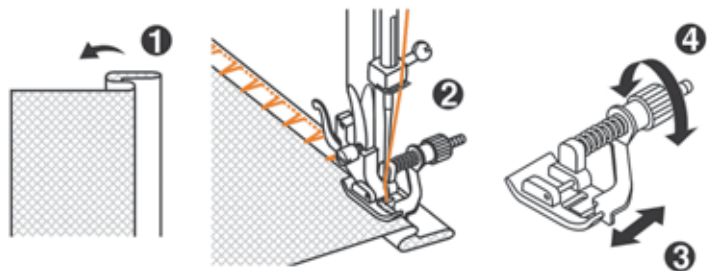

ONE STEP BUTTONHOLES



Buttonhole sewing is a simple process that provides reliable results. Always sew a practice buttonhole on a sample of your fabric and interfacing.

Making a Buttonhole

1. Using tailor's chalk, mark the position of the buttonhole on the fabric.
2. Attach the buttonhole foot and set the pattern selector dial to . Set stitch length dial to . Adjust stitch width to desired width: 3 for narrow buttonhole and 5 for wide buttonhole.
3. Lower the presser foot aligning the marks on foot with the marks on the fabric (A). (The front bar tack will be sewn first.)
4. Open the button plate and insert the button (B).
5. Lower the buttonhole lever and gently push it back (C).
6. While lightly holding the upper thread, start sewing.
7. Buttonhole stitching is done in the order shown in the diagram (D).
8. Stop the machine when the buttonhole is sewn.



Making a Buttonhole on Stretch Fabrics (E)

When sewing buttonholes on stretch fabric, hook heavy thread or cord under the buttonhole foot. When the buttonhole is sewn the satin columns will sew over the cord.

1. Mark the position of the buttonhole on the fabric with the tailor's chalk, attach the buttonhole foot, and set the pattern selector dial to . Set stitch length dial to .

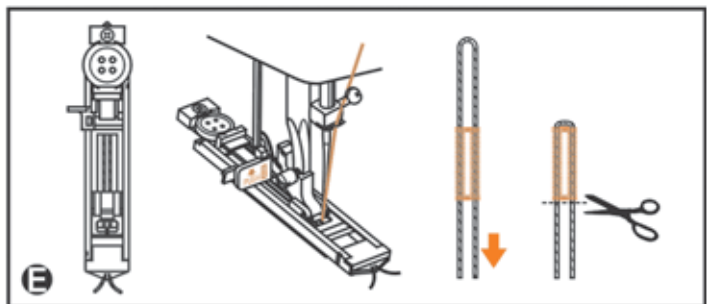
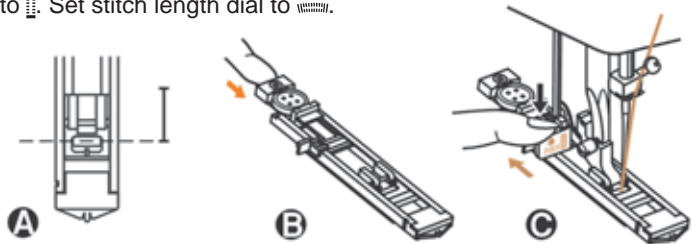

2. Hook the heavy thread onto the back of the buttonhole foot, then bring the two heavy thread ends to the front of the foot, insert them into the grooves and temporarily tie them there.
3. Lower the presser foot and start sewing.
 - * Set the stitch width to match the diameter of the gimp thread.
4. Once sewing is completed, gently pull the heavy thread to remove any slack, then trim off the excess.

LEFT AND RIGHT SIDE BALANCE FOR BUTTONHOLE

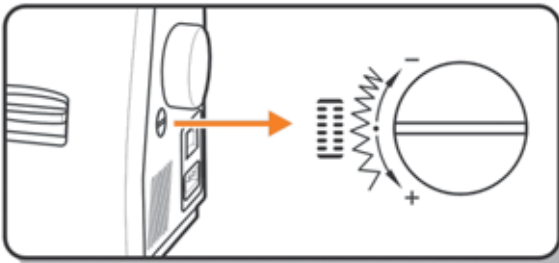

Stitch density on right and left sides of buttonhole can be adjusted with the buttonhole balance control dial near the handwheel.

This dial should usually be in a neutral position (between + and -).

If the stitches on the left side of the buttonhole are too close together, turn the dial to the left (+). Turning dial to the left makes zigzag stitches in the left column further apart.

If the stitches on the left side of the buttonhole are too open, turn the dial to the right (-). Turning dial to the right brings the zigzag stitches on the left side closer together (more dense).

The stitch on the right side of the buttonhole is set using the stitch length dial.

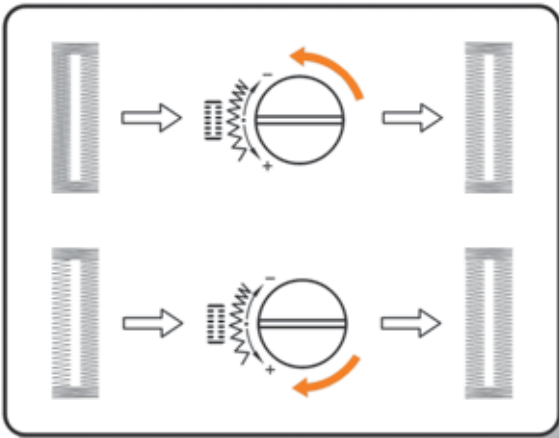

ZIPPERS AND PIPING



Set the machine as illustrated. Pattern selector on "A".
Set stitch length control between "1" - "4" (according to thickness of fabric).

The zipper foot can be snapped onto the right or left of the shank/ankle, depending on which side of the zipper you are going to sew. (1)



To sew past the zipper pull, lower the needle into the fabric, raise the presser foot and push the zipper pull behind the presser foot. Lower the foot and continue to sew.

It is also possible to sew in a length of cord, into a bias strip to make piping (2).

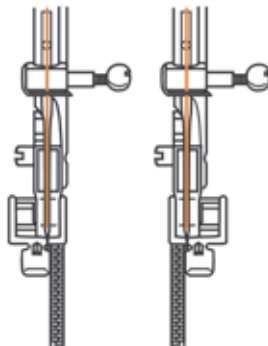
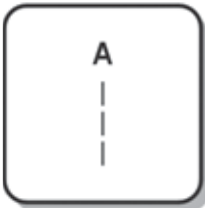

1

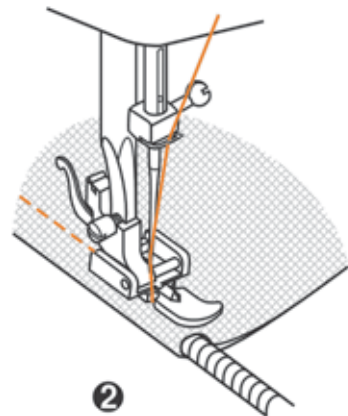

2

3-STEP ZIG-ZAG



Sewing on lace and elastic, darning, mending, reinforcing edges.

Set the machine as illustrated. Pattern selector on "E".

Stitch width 3-5

Place patch in position. The stitch length can be shortened to produce very close stitches. (1)



When mending tears, it is advisable to use a piece of backing fabric to reinforce. The stitch density can be varied by adjusting the stitch length. First sew over the center and then overlap on both sides.

Depending on the type of fabric and damage, sew between 3 and 5 rows. (2)

Sewing elastic

1. Place the elastic on the fabric.
2. As you sew, stretch the elastic both in the front and behind the presser foot as shown in fig. (3)



Joining fabric

The elastic stitch can be used to join two pieces of fabric together and is very effective when sewing knitted fabrics. If nylon thread is used, the stitch will not be visible.

1. Place the edges of the two pieces of fabric together and center them under the presser foot.
2. Sew them together using the 3-step zigzag stitch taking care to keep the two fabric edges close together as shown in fig. (4)

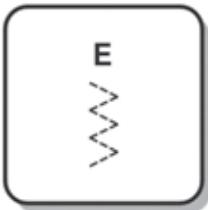

1

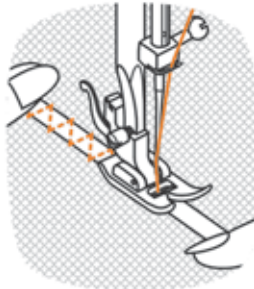

3

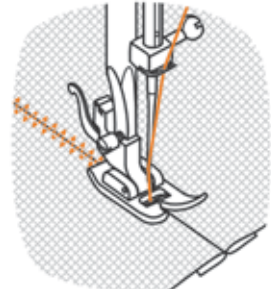

4

STRETCH STITCH SELECTION



Triple straight stitch: (1/3)

Pattern selector on "A".

For reinforced seams.

Turn the stitch length dial to "S".

The machine sews two stitches forwards and one stitch backwards.

This gives triple reinforcement.

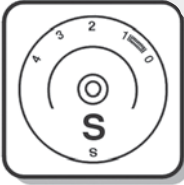

Triple zig-zag: (2/4)

Pattern selector on "B".

For reinforced seams, hems and decorative seams.

Turn the stitch length dial to "S".

Adjust the stitch width dial to between "3" and "5".

Triple zig-zag is suitable for firm fabrics like denim, corduroy, etc.



①



②

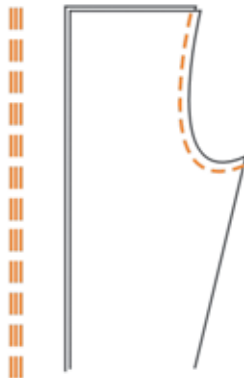

③

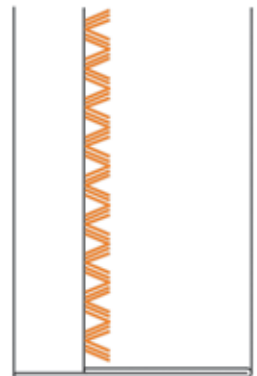

④

FREE MOTION DARNING



Set the machine as illustrated.

Move the feed dog adjustment lever to right side to lower the feed dogs. (1)

Remove the presser foot shank. (2)

Attach the darning foot to the presser foot bar. The lever (A) should be behind the needle clamp screw (B). Press the darning foot on firmly from behind with your index finger and tighten the screw (C). (3)



First sew around the edge of the hole (to secure the threads).

(4) First row: Always work from left to right. Turn work by 1/4 and oversew.

A darning hoop is recommended for easier sewing and better results.

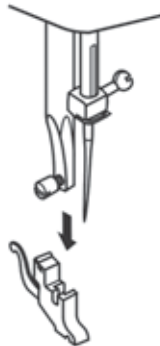
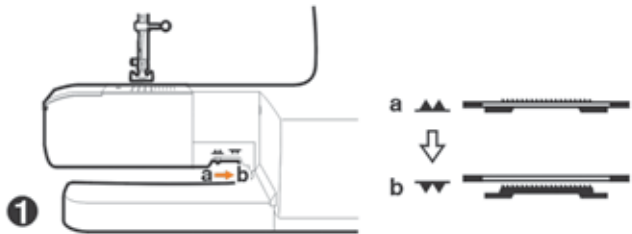
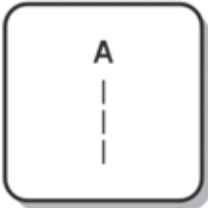

2

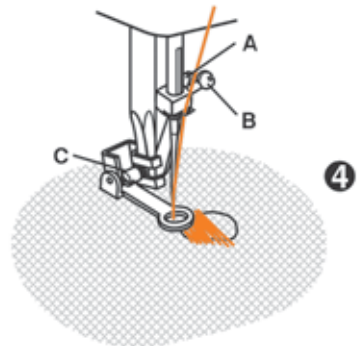

3

4



DARNING



- Turn stitch length dial to the desired length.
- Turn stitch selector to straight stitch, center needle position.
- Position the fabric to be darned under the presser foot with the underlay fabric.
- Lower the presser foot and alternately sew forward and reverse using the reverse lever.
- Repeat this motion until the area to be darned is filled with rows of stitching.

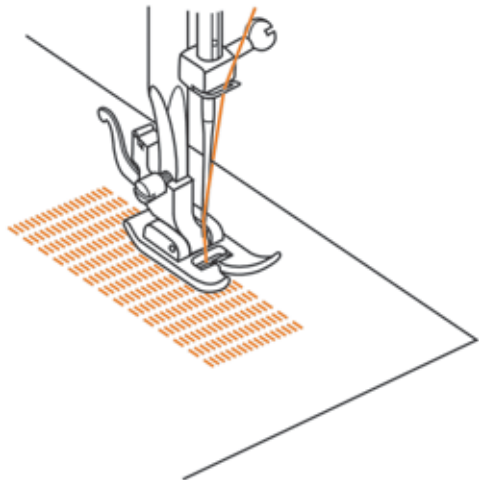

QUILTING



Set pattern selector as illustrated.

Insert the quilting guide in presser foot shank and set the space as you desired.



Move the fabric over and sew successive rows with the guide riding along on the previous row of stitching.

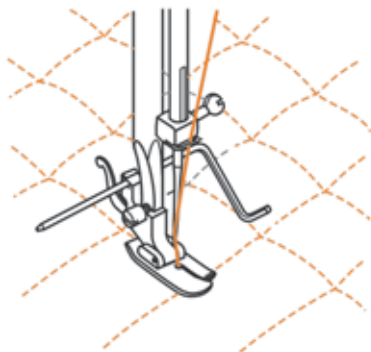
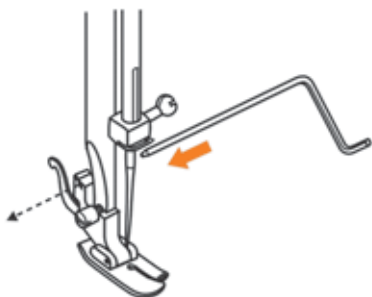
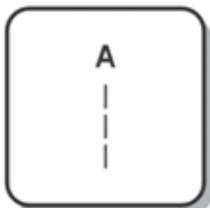
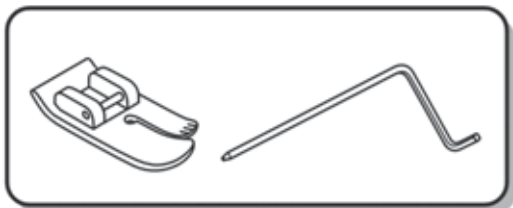

MAINTENANCE



Caution: Always make sure the machine is unplugged from the power source and the main switch is on “O” before inserting or removing any parts and before cleaning.

Remove the stitch plate:

Turn the handwheel until the needle is fully raised. Open the hinged front cover and unscrew the needle plate screw with the screw driver. (1)

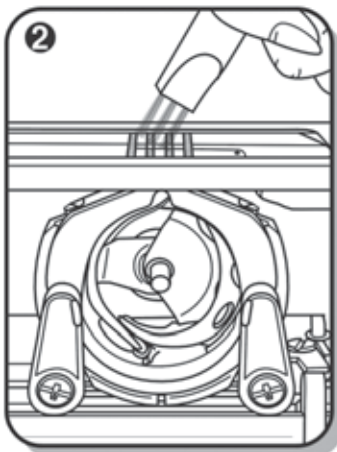

Cleaning the feed dog:

Remove the bobbin case and use the brush supplied to clean the whole area. (2)

Cleaning and lubricating the hook:

Remove the bobbin case. Snap the two hook retaining arms (a) outwards. Remove the hook race cover (b) and the hook (c) and clean with a soft cloth. Lubricate at the points (d) (1-2 drops) with sewing machine oil. Turn the handwheel until the hook race (e) is in the left position. Replace the hook (c). Replace the hook race cover and snap back the two hook retaining arms. Insert the bobbin case and bobbin and replace the stitch plate.

Important: Fabric fluff and threads must be removed regularly. Your machine should be serviced at regular intervals at one of our service agencies.

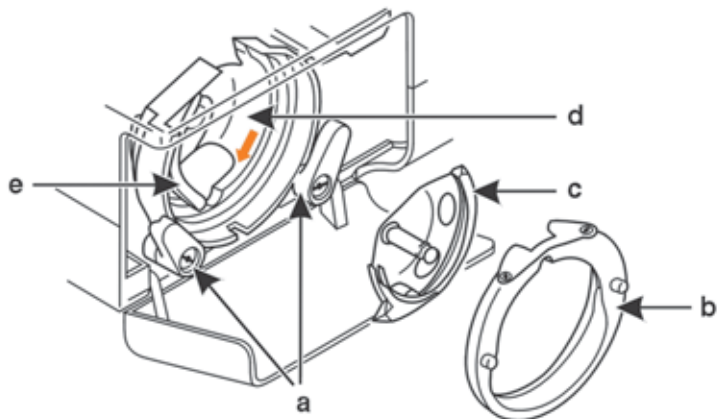

TROUBLESHOOTING GUIDE

Problem	Cause	Correction
Upper thread breaks	<ol style="list-style-type: none"> 1.The machine is not threaded correctly 2.The thread tension is too tight 3.The thread is too thick for the needle 4.The needle is not inserted correctly 5.The thread is wound around the spool holder pin 6.The needle is damaged 	<ol style="list-style-type: none"> 1.Rethread the machine 2.Reduce the thread tension (lower number) 3.Select a larger needle 4.Remove and reinsert the needle (flat side towards the back) 5.Remove the spool and thread again 6.Replace the needle
Lower thread breaks	<ol style="list-style-type: none"> 1.The bobbin case is not inserted correctly 2.The bobbin case is threaded incorrectly 3.The lower thread tension is too tight 	<ol style="list-style-type: none"> 1.Remove and reinsert the bobbin case and pull on the thread. The thread should pull easily 2.Check both bobbin and bobbin case 3.Loosen lower thread tension as described
Skipped stitches	<ol style="list-style-type: none"> 1.The needle is not inserted correctly 2.The needle is damaged 3.The wrong size needle has been used 4.The foot is not attached correctly 	<ol style="list-style-type: none"> 1.Remove and reinsert needle (flat side towards the back) 2.Insert a new needle 3.Choose a needle to suit the thread and fabric 4.Check and attach correctly
Needle breaks	<ol style="list-style-type: none"> 1.The needle is damaged 2.The needle is not correctly inserted 3.Wrong needle size for the fabric 4.The wrong foot is attached 	<ol style="list-style-type: none"> 1.Insert a new needle 2.Insert the needle correctly (flat side towards the back) 3.Choose a needle to suit the thread and fabric 4.Select the correct foot
Loose stitches	<ol style="list-style-type: none"> 1.The machine is not correctly threaded 2.The bobbin case is not correctly threaded 3.Needle/ fabric/ thread combination is wrong 4.Thread tension wrong 	<ol style="list-style-type: none"> 1.Check the threading 2.Thread the bobbin case as illustrated 3.The needle size must suit the fabric and thread 4.Correct the thread tension
Seams gather or pucker	<ol style="list-style-type: none"> 1.The needle is too thick for the fabric 2.The stitch length is wrongly adjusted 3.The thread tension is too tight 	<ol style="list-style-type: none"> 1.Select a finer needle 2.Shorten the stitch length 3.Loosen the thread tension
Uneven stitches, uneven feed	<ol style="list-style-type: none"> 1.Poor quality thread 2.The bobbin case is wrongly threaded 3.Fabric has been pulled 	<ol style="list-style-type: none"> 1.Select a better quality thread 2.Remove bobbin case and rethread and insert correctly 3.Do not pull on the fabric while sewing, let it be fed by the feed dogs
The machine is noisy	<ol style="list-style-type: none"> 1.The machine must be lubricated 2.Fluff or oil have collected on the hook or needle bar 3.Poor quality oil has been used 4.The needle is damaged 	<ol style="list-style-type: none"> 1.Lubricate as described 2.Clean the hook and feed dog as described 3.Only use good quality sewing machine oil 4.Replace the needle
The machine jams	Thread is caught in the hook	Remove the upper thread and bobbin case, turn the handwheel backwards and forwards by hand and remove the thread pieces. Lubricate as described



Please note that on disposal, this product must be safely recycled in accordance with relevant National legislation relating to electrical/electronic products. If in doubt please contact your retailer for guidance

