



LAVINA® 32R -S User Manual



Tech Support Line: 800-987-8403 | www.superabrasive.com | info@superabrasive.us

Table of Contents

1. GENERAL INFORMATION.....	3	Pulley Unit Exploded View (fig.7.4).....	13
Manufacturer.....	3	Motor Support Exploded View (fig.7.5).....	13
General Description.....	3	Central Shaft Bearing Exploded View (fig.7.6).....	14
Machine characteristics.....	3	Top Cover Exploded View (fig.7.7).....	14
Lavina® 32R-S/32R-S-HV Main design.....	3	Guard Assembly Exploded View (fig.7.8).....	14
Environmental Conditions.....	4	Carriage Exploded View (fig.7.9).....	14
Electrical Connection.....	4	Steering Bracket Exploded View (fig.7.10).....	14
Vacuum Connection.....	4	Tool Holder Exploded View (fig.7.11).....	14
Technical Data.....	4	8. MAINTENANCE AND INSPECTION.....	15
Vibrations.....	4	Cleaning.....	15
Sonorous Emissions.....	4	Check Daily.....	15
Label Data.....	4	Check after the first 15 Working Hours.....	15
Customer Service.....	4	Check Every 200 Working Hours.....	15
2.SAFETY ISTRUCTIONS.....	5	Check Every 400 Working Hours.....	15
Recommended Use.....	5	Vacuum.....	15
Prohibited Use.....	5	Water Leaks.....	15
Preparation for work.....	5	Electrical System.....	15
Protection Devices.....	5	Mechanical Parts.....	15
Arrest Functions.....	5	Carriage Wheels.....	15
Safe Use.....	5	Battery Of The Driving.....	16
Residual Risks.....	5	Baterry of the PANEL.....	16
Before You Begin.....	5	Lavina® 32R-S Electrical schemes with Yaskawa Inverter 200-240 Volt ..	17
Operating Machine.....	5	Lavina® 32R-S-HV Electrical schemes with Yaskawa Inverter 380-480 Volt.....	18
After Work is completed.....	5	9. TROUBLESHOOTING.....	21
The Work Area.....	5	Index of Problems and Solutions.....	21
Personal Protective Equipment (ppe).....	5	9.1 Replacing Power Cord and Plugs.....	21
Operator.....	6	9.2 Dismounting And Mounting Tool Holder.....	21
3. HANDLING AND TRANSPORTATION.....	6	9.3 Tensioning used planetary Belt.....	22
Positioning the handle.....	6	9.4 Mounting and tensioning a new planetary belt.....	22
Using The Steering Bracket.....	6	9.5 tensioning and replacing the belts.....	22
Flipping the machine up.....	7	9.6 replacing the PULLEYS.....	23
Splitting the carriage from the main head.....	7	9.7 replacing the wheel.....	23
Lifting.....	7	9.8 replacing the Battery.....	23
Leading power cable.....	8	9.9 Motor connection.....	23
Third wheel.....	8	Fault list LAVINA® 32R-S.....	24
Releasing The Wheels Of The Carriage.....	8	Fault diagnosis Inverter YASKAWA V1000.....	25
Storage.....	8	9. WARRANTY AND RETURNS.....	28
4. OPERATION.....	9	Return Policy for Lavina® 32R-S/32R-S-HV.....	28
Preliminary Controls.....	9	10. DISPOSAL.....	28
Control of the waterflow.....	9	11. MANUFACTURER'S CONTACTS.....	28
Adjusting and Mounting Tools.....	9	12. SPARE PARTS.....	29
FRAME BLOCKING (u-joint).....	9	1. LAVINA®32R-S General Parts.....	29
Control Panel.....	9	2. LAVINA®32R-S Tool Holder For Machines Parts.....	29
Control And Indication Units On The Electrical Cabinet.....	10	3. LAVINA®32R-S Bottom Cover Assembly Parts.....	29
Starting the Machine.....	10	4. LAVINA®32R-S Pulley Unit Parts.....	30
Operating the Machine.....	11	5. LAVINA®32R-S Bottom Cover Assembly Parts.....	30
Stopping the Machine.....	11	6. LAVINA®32R-S Central Shaft Bearing Parts.....	31
Alarm.....	11	8. LAVINA®32R-S Guard Assembly Parts.....	31
5.TOOLS AND ACCESSORIES.....	11	9. LAVINA®32R-S Carriage Parts.....	32
Weights.....	11	10. LAVINA®32R-S Steering Bracket Parts.....	33
Tool holder key.....	11	11. LAVINA®32R-S Water Supply Parts.....	33
Foam Plate.....	11	12. LAVINA®32R-S Tool Holder Parts.....	Error! Bookmark not defined.
Security plate for Quickchange pads.....	11	13. LAVINA®32R-S motor FAN Parts.....	33
6. POPULAR TOOLS.....	12	14. Lavina® 32R-S Control Box Parts 200-240 Volt.....	34
7. EXPLODED VIEW.....	13	LAVINA®32R-S Control Box Parts 200-240 Volt.....	34
General Exploded View (fig.7.1).....	13	15. Lavina® 32R-S-HV Control Box Parts 380-480 Volt.....	35
Tool Holder For Machines Exploded View (fig.7.2).....	13	LAVINA®32R-S-HV Control Box Parts 380-480 Volt.....	35
Bottom Cover Assembly Exploded View (fig.7.3).....	13		

1. GENERAL INFORMATION

This owner's manual is intended for the operator of the Lavina® 32R-S/32R-S-HV machine, the servicing technician as well as for anyone involved with operating or servicing the machine. We recommend that you read the instructions very carefully and follow them strictly. The manual includes information about assembling, using, handling, adjusting and maintaining your Lavina® 32R-S/32R-S-HV floor grinding and polishing machine.

MANUFACTURER

Superabrasive was founded in 1987, as a manufacturer of high quality diamond tools for the stone and concrete industry. Today, Superabrasive is one of the world's leading companies in the production of diamond tools and floor grinding machinery. At Superabrasive, we strive to deliver the very best solutions to our customers, and enable them to work more efficiently.

GENERAL DESCRIPTION

The Lavina® 32R-S/32R-S-HV machine is intended for grinding, polishing and buffing concrete, marble, granite, limestone and terrazzo surfaces with diamond tools.

The Lavina® 32R-S/32R-S-HV is a six-disc machine with remote control, and can be used dry as well as wet. For best results, use only tools manufactured or recommended by Superabrasive and its distributors.

WARNING!

The Lavina® 32R-S/32R-S-HV machine is manufactured and fitted for the above-mentioned applications only! Every other use may possess risks to the persons involved.

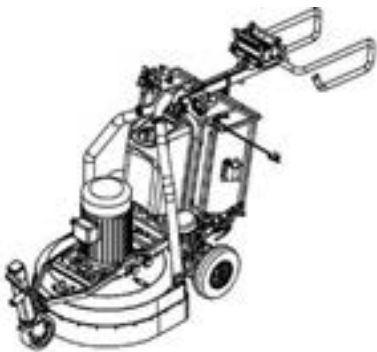

Figure 1.1

MACHINE CHARACTERISTICS

The Lavina® 32R-S/32R-S-HV is made of two main component sections:

LAVINA® 32R-S/32R-S-HV MAIN DESIGN

The two main component sections, the carriage and main head.

The wheels of the carriage are driven by two gear boxes that allow working with the machine from distance. The handle on the frame is adjustable in height and enables the operator to work in a correct and safe posture.



Figure 1.2

Two halogen spotlights (Fig.1.2) enable the operator to work in darker areas. The lamp holder can be adjusted in different positions.

⚠ WARNING Existing lighting system does not replace adequate overhead lighting.

A **frame (U-joint technology)** on top of the motor base is providing the main head a possible to move to all sides and it gives more grinding capacity.

Remote Control Unit (fig.1.3)



Figure 1.3

The electrical box (fig.1.4) contains the electric switching devices and inverters. The motor feeding cable is plugged in the socket located on the bottom of the box. The **main feeding cable** is connected with a plug and socket on the side of the box. **The battery** is situated under the electrical box and allows to move the machine without connection with the current supply.

The water tank is on the opposite side of the frame, so that the weight of the water has no influence on the operation of the machine. The water from the tank is supplied by a pump. The frame weight, on the other hand, is fully absorbed by the driving

wheels.

The working part motor is mounted on the base plate and is the six grinding heads are driven by a two-belt system. The **planetary head** is driven by a third flat belt.

The machine has a third wheel which ensures easier movement. (Fig.1.4)



Figure 1.4

ENVIRONMENTAL CONDITIONS

The temperature range for operating the Lavina® 32R-S/32R-S-HV outdoors is between 41°F and 86°F or 5°C and 30°C. Never use the Lavina® 32R-S/32R-S-HV during rain or snow when working outdoors. When working indoors, always operate the machine in well-ventilated areas.

ELECTRICAL CONNECTION

The voltage (Volt) and power (Ampere) are displayed on a label on the electrical control box to avoid any incorrect connection. Refer to these before connecting the power. To avoid electrical shocks, make sure the ground power supply is functioning properly.

VACUUM CONNECTION

A connection for a vacuum dust extractor is located on the carriage. The Lavina® 32R-S/32R-S-HV does not include a vacuum dust extractor. The customer must purchase the vacuum dust extractor separately. The hose of the vacuum extractor must be Ø 76 mm/3 Inch and can be glided over the three-way pipe. The vacuum dust extractor must be adapted for floor grinders and have a minimum air displacement of 500m³/h with a negative vacuum of 21 kPa.

TECHNICAL DATA

	Lavina® 32R-S		Lavina® 32R-S-HV	
Voltage/Hz	3ph x 200-240 V 50/60Hz		3ph x 380-460 V 50/60Hz	
Amperage	60 Amps		31 Amps	
Power	15.75 kW	21 hp	15.75 kW	21 hp
Tool holder rpm	300-1100 rpm		300-1100 rpm	
Working width	811mm	32"	811mm	32"
Tool holder diameter	6 x 225 mm	6 x 9"	6 x 225 mm	6 x 9"
Weight	579 kg	1278lbs	579 kg	1278lbs
Grinding pressure	286 kg	631 lbs	286 kg	631 lbs
Additional weight	max 2x29kg	2x64 lbs	max 2x29kg	2x64 lbs
Application	wet and dry		wet and dry	
Vacuum hose port	76 mm	3"	76 mm	3"
Water attachment	Quick change for ¾" hose		Quick change for ¾" hose	
Water tank capacity	46 l	12 gal	46 l	12 gal
Water feed	Peripheral and front stream with pump		Peripheral and front stream with pump	
Cable length	17.4 m	57 ft	17.4 m	57 ft
Third wheel	yes		yes	
AMG Battery	12V/85AH		12V/85AH	
Duration of movement of the machine without re-charging the battery	Max 30 minutes		Max 30 minutes	
Remote control battery	Rechargeable battery size AA 1.2V		Rechargeable battery size AA 1.2V	
Machine LxWxH	2335x850x1260 mm	92"x34"x50"	2335x850x1260 mm	92"x34"x50"
Packing LxWxH	1430x950x1280 mm	56"x37"x51"	1430x950x1280 mm	56"x37"x51"

VIBRATIONS

The vibrations of the machine are within the limits of directives and harmonized standards from the European Union when the Lavina® 32R-S/32R-S-HV is operated with the recommended tools and in normal conditions.

SONOROUS EMISSIONS

The sonorous emissions are within the limits of directives and harmonized standards from the European Union when the Lavina® 32R-S/32R-S-HV is operated with the recommended tools and in normal conditions. However, as previously stated, the operator must wear ear protectors.

LABEL DATA

The data on the label provides the correct voltage and kW (needed for operational purposes); Weight (needed for transportation purposes); production year and serial number (needed for maintenance purposes).

CUSTOMER SERVICE

For customer assistance and technical support call your local distributor or call Superabrasive Inc. at 1-800-987-8403 or visit us at www.superabrasive.com, where you can download a copy of this manual.

2.SAFETY ISTRUCTIONS

RECOMMENDED USE

The Lavina® 32R-S/32R-S-HV machine is designed and manufactured to grind and polish concrete, terrazzo and natural stone floors. It can be used for renovations as well as for polishing. The machine is designed for dry or wet use. When using it dry, use a vacuum of appropriate size. For more information, please refer to the chapter on handling the vacuum connection.

PROHIBITED USE

The machine MUST NOT be used:
 For applications different from the ones stated in the General Description chapter.
 For not-suitable materials.
 In environments which:
 Possess risks of explosion
 Possess high concentration of powders or oil substances in the air
 Possess risks of fire
 Feature inclement conditions.
 Possess electromagnetic radiation.

PREPARATION FOR WORK

Make sure that:
 You have closed the work area, so that no person unfamiliar with operating the machine can enter the area
 The tool plate and tools are adjusted to the machine properly
 There are no missing parts of the machine
 The machine is in upright working position
 The protection devices are working properly.
 The electrical cable is free to move and follow the machine easily. In order to keep the electrical cable from being damaged, no vehicle should cross the zone where electrical cables are situated.

PROTECTION DEVICES

The machine is equipped with several protection devices including the following:
 An emergency stop button
 A protection skirt and a hood for protecting the tool plates.
 These devices protect the operator and/or others persons from potential injuries. Do not remove them. On contrary, before using the machine, please ensure that all protection devices are mounted and function properly.

ARREST FUNCTIONS

Functions of arresting of the machine are following:
 Button to stop the motor (category 1)
 Emergency button (category 1)

SAFE USE

The Lavina® 32R-S/32R-S-HV is designed to eliminate all risks correlated with its use. However, it is not possible to eliminate the risks of an eventual accident with the machine. Unskilled or uninstructed operator may cause correlated residual risks. Such risks are:

Position Risks due to operator's incorrect working position
 Tangling up Risks due to wearing inappropriate working clothes
 Training Risks due to lack of operational training

⚠ WARNING

⚠ WARNING

⚠ WARNING

⚠ WARNING

⚠ WARNING

⚠ WARNING

NOTE: In order to reduce all consequences of the above-mentioned risks, we advise that machine operators will follow the instructions in the manual at all times.

RESIDUAL RISKS

During the normal operating and maintenance cycles, the operator is exposed to few residual risks, which cannot be eliminated due to the nature of the operations.

BEFORE YOU BEGIN

Working area must be clear from any debris or objects.
 A first-time operator must always read the manual and pay attention to all safety instructions.
 All electric connections and cables must be inspected for potential damages.
 Ground wire system of the power supply must be also inspected.
 Perform general daily inspections of the machine and inspect the machine before each use.
 Always inspect the safety devices:
 The emergency break must be clear and working
 The tool protector must be working
 The machine must be clean
 Never operate the machine in the rain!
 Confirm that there are no missing parts especially after transportation, repair or maintenance.
 Before filling the water tank with water make sure the machine is not working and the main switch is turned off.
 Before turning on the machine make sure that the base is placed on the floor, the machine MUST NOT be in an upright position when turned on!

OPERATING MACHINE

Never work with the machine without visual contact with it.
 Never run the machine when you are situated between the handles of the wheel
 When operating the Lavina® 32R-S/32R-S-HV, make certain that there is no one, but you around the machine.
 Never leave the machine unattended while working.
 The electrical cable must move freely and must be damage-free.
 The water hose must move freely and must be damage-free.
 Check if the floor, you work on, is not too uneven. If this is the case, it may damage the machine.

AFTER WORK IS COMPLETED

Clean the machine and its surroundings properly
 Empty and clean the water tank
 Unplug the machine and wind up the electrical cable
 Store the machine in a safe place

THE WORK AREA

Make certain that people or vehicles do not enter the work area.
 Avoid cables and hoses being in the way.
 Always check the floor for debris

PERSONAL PROTECTIVE EQUIPMENT (PPE)

Always wear safety shoes when working with the machine.
 All personnel in the immediate work area must wear safety glasses with side shields.

Always wear safety gloves when changing the tools.
Always wear clothes suitable for the work environment.

The operator must understand all the instructions in this manual.

OPERATOR

⚠ WARNING

The operator Lavina® 32R-S/32R-S-HV machine must have an adequate technical knowledge and preparation. The operator must know the machine's work environment.

The operator must understand and interpret all the drawings and designs in manual.

The operator must know all sanitation and safety regulations pertaining to the operation of

The operator must have floor grinding experience.

The operator must know what to do in case of emergency

Only one operator at a time can work with the machine.

The operator must be properly trained and well instructed prior operating the machine.

3. HANDLING AND TRANSPORTATION

POSITIONING THE HANDLE



Figure 3.1



Figure 3.2



Figure 3.3

USING THE STEERING BRACKET

By loosening the swivel bolt (Fig. 3.1-2), turn the steering bracket (Fig. 3.1-3) in position. To turn the steering bracket down (Fig. 3.1-3) you have to turn loose the swivel bolt (Fig. 3.1-2), and push it in, this for security reasons.



Figure 3.4



Figure 3.5



Figure 3.6



Figure 3.7



Figure 3.8

The handle can be positioned in three positions: Transport position to store or to transport or to hoist the machine (fig. 3.4)

Working position (fig. 3.5) and Flipping position (fig. 3.6)

To change the handle positions pull the knob (Fig. 3.1-1, Fig. 3.7, and Fig. 3.8), move the handle up or down.



Figure 3.9



Figure 3.10

To choose the transport-position pull the additional the security pin (Fig. 3.9, Fig. 3.10) out and put it back in when the handle is in position. Never lift the machine on the handle without mounting this pin.

FLIPPING THE MACHINE UP

To change the tools put the handle in the flipping (upright) position (Fig. 3.11), grab the steering bracket and pull the machine with all your bodyweight down (one foot on the control box can help) Put the bracket down on the floor (Fig. 3.12) and change tools. While putting the machine down a foot on the control box helps again.



Figure 3.11



Figure 3.12

SPLITTING THE CARRIAGE FROM THE MAIN HEAD



Figure 3.13



Figure 3.14



Figure 3.15



Figure 3.16



Figure 3.17



Figure 3.18

Unplug the motor cable plug from the control box (Fig. 3.13) and disconnect the water hose from the main head by pulling it out (Fig. 3.14) and (Fig. 3.15). Release the pin sets (Fig. 3.16) and dismantle the third wheel. Release the pin sets (Fig. 3.17) which attach the head to the carriage and divide the carriage from the main head (Fig. 3.18).



Figure 3.19

LIFTING

Lifting the machine by crane is possible by using the hoisting ring mounted on the carriage (see Fig.3.19). The eye bolt and machine construction is rated only for the weight of the machine. Do not lift any other loads on the machine. Use always hoisting equipment rated for 600 kg or 1300 lbs. See to it the security pin (Fig. 3.9, Fig. 3.10) is mounted.

LEADING POWER CABLE

There is the possibility to lead the power cable through a shackle mounted on the hoisting ring.(see fig. 3.20).

There is a possibility to lead the power cable on sides of the machine on a specially mounted bearer (fig. 3.21; fig.3.22).

On side the cable can be leaded to the left or to the right side according to the operator request. The bearer is put away when is not in use, as shown on fig. 3.23.



Figure 3.20



Figure 3.21



Figure 3.22



Figure 3.23



Figure 3.24

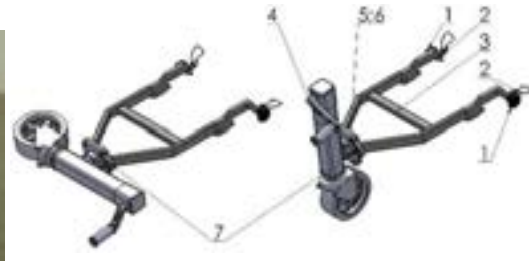

Figure 3.25

THIRD WHEEL

Lavina® 32R-S/32R-S-HV has a third wheel for easier movement. Lift the operating part using the jack wheel and with the energy of the battery move the machine on its own power. Mounting/Dismounting with Pin assembly (see Fig. 3.25 1-2). While working there is a possibility to turn the wheel support 90°(Fig.3.25). Pull out the wheel support, turn it 90 ° and fix again.

RELEASING THE WHEELS OF THE CARRIAGE

If on some reason the movement of the machine is not possible on its own power (using the third wheel), it can be done on the two wheels of the carriage by the operator. Each of the wheels can be released from gearing to the driven shaft by unscrewing the bolt (Fig.3.26-1) by 3 revs. This way is released the saw-edged bush, which transmits the movement between the shaft and the wheel. To unscrew the bolt you need a wrench 19mm (3/4 in) (Fig.3.27). When turning on/off the connector of the wheel is good to lift the carriage so the wheel does not touch the floor and has free rotation (Fig.3.28).



Figure 3.26



Figure 3.27



Figure 3.28

STORAGE

Always store and transport the Lavina® 32R-S/32R-S-HV in a dry place. Never transport the Lavina® 32R-S/32R-S-HV unprotected; it may be damaged if transported unprotected during rain or snow.

⚠ WARNING When during the storage of the machine the temperature may fall down to or less 32F (or 0° C) you should empty the water from the system using following steps:

- Pull out the hose of the tank (Fig.3.29)
- Using compressed air blow out the water from the system for the two positions of the turn-cock (Fig. 3.30, Fig. 3.31).



Figure 3.29



Figure 3.30



Figure 3.31

4. OPERATION

PRELIMINARY CONTROLS

Inspect the working area as explained in the safety instructions. For wet use, fill in the water tank when the electrical cable is disconnected. Connect the vacuum extractor and ensure that the vacuum hose is clear and it will follow the machine easily. Plug in the machine and make sure that the power cord is free to follow the working direction of the Lavina[®] 32R-S/32R-S-HV.

CONTROL OF THE WATERFLOW

The operator can choose the water sprays with valve (Fig.4.2 1) in the front (fig.4.1) when the level of the tap is in the vertical position, when the level is in the horizontal position water will spray under cover of the machine.

The valve (Fig. 4.2 2) is controlling the flow of an external water supply. A $\frac{3}{4}$ " water tube can be attached to the quick connection (Fig. 4.2 3).



Figure 4.1



Figure 4.2



Figure 4.3



Figure 4.4

ADJUSTING AND MOUNTING TOOLS

Mount the tools only after ensuring that there is enough diamond bond material left. Be sure that the plates are always clean before mounting. **WARNING:** Secure always the "Quickchange" pads with the security plate (Fig.4.3), lock with the tool holder key (Fig.5.3). Diamond tools with Velcro are attached on six foam plates of 9 inch (Fig.4.4). The foam plates are mounted on the key lock (butterfly). Always use the tool holder key (Fig.5.3).

FRAME BLOCKING (U-JOINT)



Figure 4.6



Figure 4.7

The relation between the working head and the trolley is the frame (U-joint), which allows rotation about two perpendicular axes to better follow the profile of the floor.

The movement round one of axis can be blocked with two screws to the plank, mounted on the front of the frame (Fig.4.6). Unscrew the bolts and turn the plank so it fixes the frame to the carrier with its tooth and then tighten the bolts (Fig.4.6). Thus the lateral movement of the machine is blocked.

CONTROL PANEL

The Control Panel can work connected to the machine or as a remote control device.



Figure 4.8



Figure 4.9



Figure 4.10



Figure 4.11

When it is connected to the machine it has to be on the support of the handle bar where on the bottom is mounted the transmitter of the panel. Unscrew the protection closure of the panel (Fig.4.8), then unscrew the nut of the plug

connecting the cable to the transmitter and connect the plug to the panel (fig4.10.). Put the protection closure to the transmitter (fig 4.11).

When the panel is working as a remote control device the cable should be connected to the transmitter.

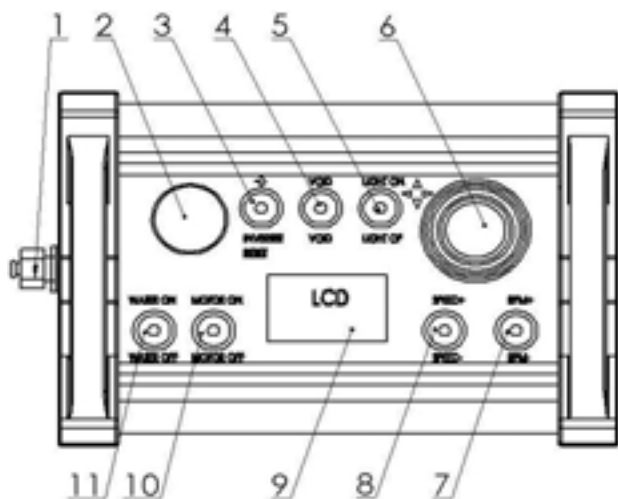

Figure 4.12

- 1 Plug with closure** used to connect the panel to the machine through a cable
- 2 Emergency STOP button** used in Emergency situations for stopping the machine. Turn on/off the panel.
- 3 Switch Reset**
 - **forward position** activates the initial setting on the control panel
 - **back position** resets the alarm of the inverters
- 4 Free switch**
- 5 Switch on/off the spotlights**
- 6 Joystick** presets the moving direction of the machine
- 7 Switch** presets the rotation speed of the plates of the toolholders
- 8 Switch** presets moving speed of the machine
- 9 LCD – Display :**
 - indication of the preset rotation speed of the working plates

- indication of the preset speed of the machine
- emergency stop button report
- report - "inverter fault"
- movement direction "forward"
- movement direction "back"

- 10 ON/OFF switch** starts/stops the motor
- 11 ON/OFF switch** control the water pump

CONTROL AND INDICATION UNITS ON THE ELECTRICAL CABINET



Figure 4.13

- 1 Emergency stop button** used in Emergency situations for stopping the machine.
- 2 Power led** lights green when the machine is connected to the current supply and is in running line.
- 3 Power switch „BATTERY-LINE”**
 - In “BATTERY” position, the machine takes power from the battery in case it is not connected to the power supply.
 - In “LINE” position, the machine takes power from the electric network and charges the battery. **In this position the machine should stay after stopping and switch-off.** In case the battery is not fully charged (after transporting it on self move) leave the machine connected to the power supply in order to charge the battery.

⚠ WARNING The time to move the machine without re-charging the battery is 30 minutes.

STARTING THE MACHINE

Follow strictly the instructions in chapter "SAFETY INSTRUCTOINS".

NEVER WORK WITH THE MACHINE WITHOUT VISUAL CONTACT WITH IT.

ATTENTION: Never run the machine when you are situated between the handles of the wheel. First turn the handles as shown on Fig.4.14.

If working wet, pour water on the floor. If working on dry surface, skip that step and connect and switch on the vacuum cleaner. Connect the machine to the electric network and the light "POWER" will light and put the „BATTERY-LINE” switch (Fig.4.13-3) in position "LINE" . Then check the "emergency stop buttons"(Fig.4.12-2) and (Fig.4.13-1) in order to be sure the machine is in working condition.

Preset the necessary rev with the switch (Fig.4.12-7) and the speed with the switch (Fig.4.12-8).

Then start the motor by swithing " Motor on" "(Fig.4.12-10) and preset movement direction from the joystick (Fig.4.12-6), by holding up the joystick for 1s in final position of the desired direction.



Figure 4.14

OPERATING THE MACHINE

Guide the machine in straight lines across the floor, and with each new line overlap a little bit of the previously completed surface. Work at a constant speed allowing the tools time to work at a speed appropriate for the tools' grit size. Avoid vibrations. Do not stop the machine in one spot while the tools are still working because they will leave marks on the floor surface. When working wet, preliminary chose with the water tap (Fig.4.2-1) the position for water feed and periodically start the pump (Fig 4.12-11) to release water onto the floor surface. Starting the pump is possible only if the machine motor is on. When working dry, check the floor surface periodically to ensure that dust is not accumulating on it. Check regularly if your vacuum works properly. In case you need you may turn on the lights (Fig.4.12-5).

STOPPING THE MACHINE

The machine can stop by switching the joystick in opposite position to the moving direction.

The stopping of the machine should be after the motor stops. Do not stop moving the machine before stopping the motor rotation. Otherwise it could damage the surface.

To stop the machine motor use switch "Motor off"(Fig.4.12-1). Use "Emergency stop button" only in emergency.

NOTE! Do not hold the machine in one spot before the motor stops to turn.

ALARM

The machine stops when the emergency stop button is activated or the inverters are shut down by emergency.

It is indicated by flickering lamp inbuilt in the switch "BATTERY-LINE".

The control panel display shows " **Emergency stop** " or " **Inverter fault** ". After eliminating the accident cause the machine is reset in working condition by releasing the emergency stop or turning on the "Inverter reset"(Fig.4.12-3).

5.TOOLS AND ACCESSORIES

WEIGHTS

Superabrasive offers additional weights for increasing the productivity of the machine (Fig.5.1). Each additional weight weighs about 64 lbs or 29 kg. The number of weights you choose to use will vary from none to two. Each individual application, type and condition of surface, power capacity of the outlet, etc. will determine the number of weights you can use without tripping a breaker. The first weight stacks on to three posts on the frame around the outer bowl (Fig.5.2). The second weight stacks onto the first.



Figure 5.1



Figure 5.2

The additional weights depend on the tools; it is not always possible to add weights. Some tools work too aggressively and the machine can stop. The weight can be ordered with item number A08.00.00.00

TOOL HOLDER KEY

The tool holder key (Fig. 5.3) is used for adjusting, mounting and dismounting of the tools. Always use the key for mounting. Item number is A03.00.00.00



Figure 5.3

FOAM PLATE

Diamond tools with Velcro are mounted on the foam plate 9"(Fig.5.4). The foam plate is mounted on the flexible backer plate. Item number is LV-9-FP-S

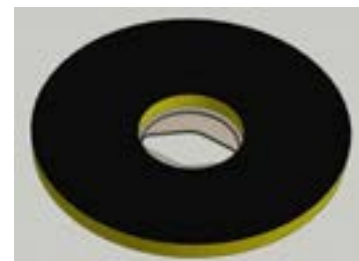

Figure 5.4



Figure 5.5

SECURITY PLATE FOR QUICKCHANGE PADS

Plate (Fig.5.5) used to ensure the "Quickchange" pads. Item number is A38.00.01

6. POPULAR TOOLS

RECOMMENDED TOOLS



QuickChange System and Tooling feature extremely fast and convenient tool changes, and a long tool life, providing for great long-term cost savings. The QuickChange pads are produced in four different bonds for super hard, hard, medium and soft concrete, in a variety of grit sizes, with either 1 or 2 buttons, which allows you to customize the aggressiveness of the cut.

Calibra grinding discs: our popular ceramic bond discs are designed for the removal of difficult scratches and they save you valuable time by eliminating the need for multiple passes with metal tools. They can be used wet or dry, and are best for hard concrete applications. They are with Velcro attachment.



NATO[®] polishing discs feature a special resin formula designed for both wet and dry applications and a unique design with wide channels allowing for work on a cleaner surface and ensuring a quality polish. Available in 3 and 4 in sizes. They are with Velcro attachment.

V-HARR[®] Premium Polishing Pads are designed for mechanically polishing and restoring concrete; also ideal for terrazzo and hard stone floors. V-HARR[®] pads are offered in a wide variety of diameters and grit sizes to accommodate many applications. Dry use is strongly recommended.

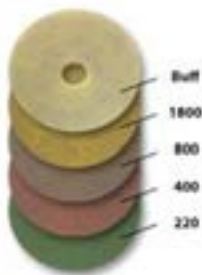

Shine Pro[®] are high quality diamond-impregnated pads for floor maintenance. Available in a variety of sizes (17, 20, 21, 27 inch and other sizes), they are designed for use under swing machines and burnishers, and are great for daily use – they require only water (no wax or chemicals needed) and are a very environmentally friendly solution for maintaining floors.

Use only Superabrasive's recommended tools see www.superabrasive.com

7. EXPLODED VIEW

GENERAL EXPLODED VIEW (FIG.7.1)

TOOL HOLDER FOR MACHINES EXPLODED VIEW (FIG.7.2)

BOTTOM COVER ASSEMBLY EXPLODED VIEW (FIG.7.3)

PULLEY UNIT EXPLODED VIEW (FIG.7.4)

MOTOR SUPPORT EXPLODED VIEW (FIG.7.5)

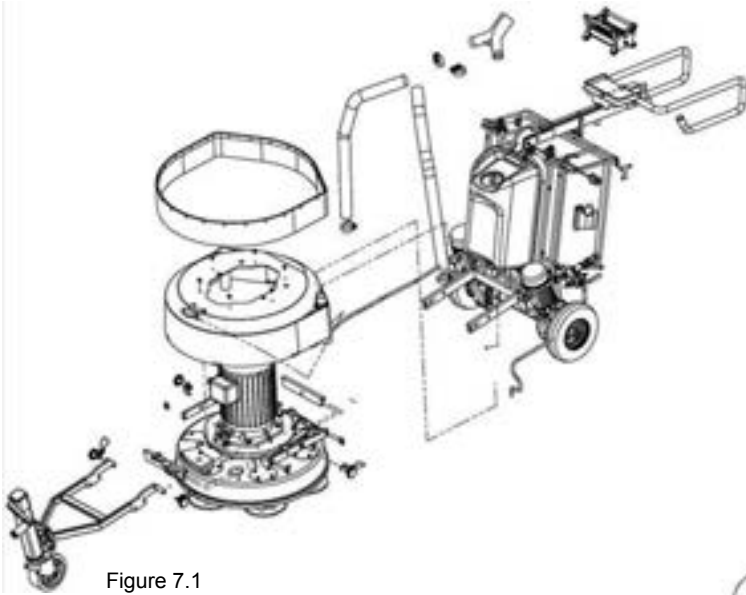

Figure 7.1

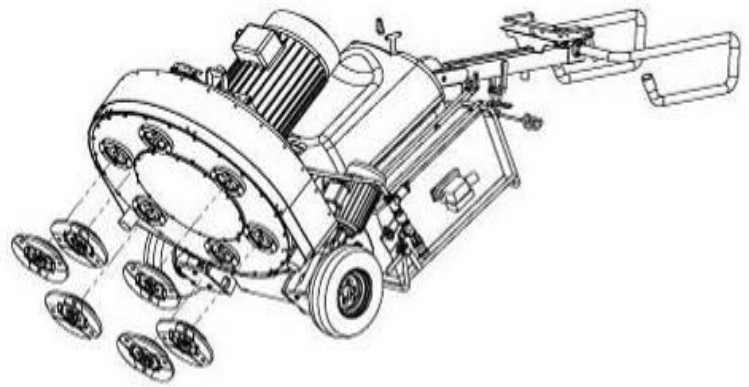

Figure 7.2

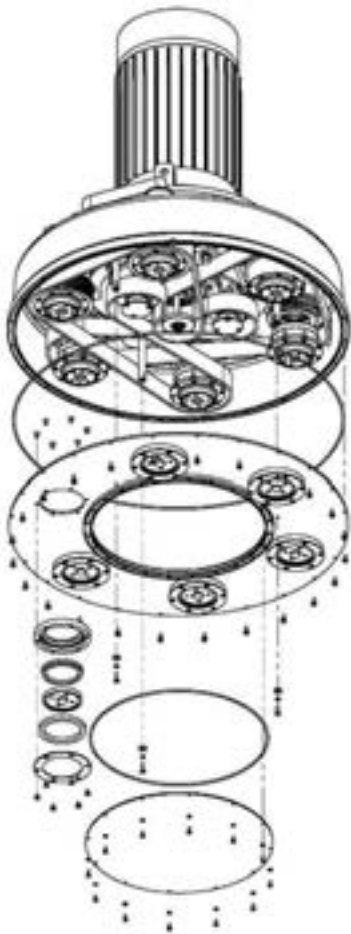

Figure 7.3

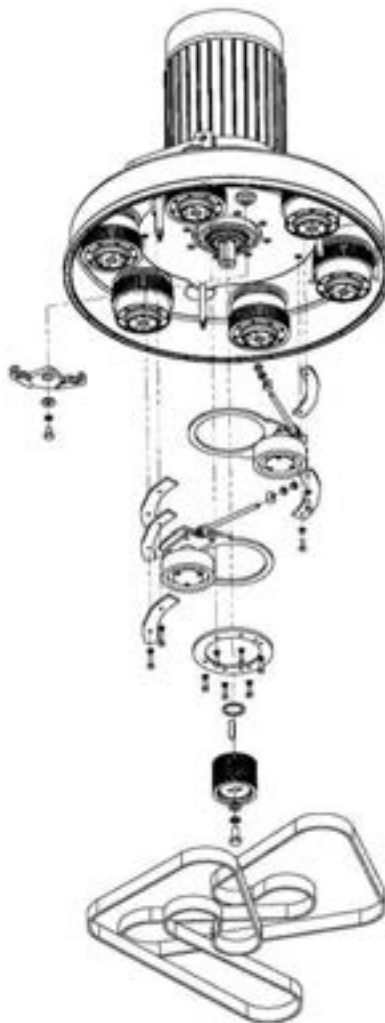

Figure 7.4

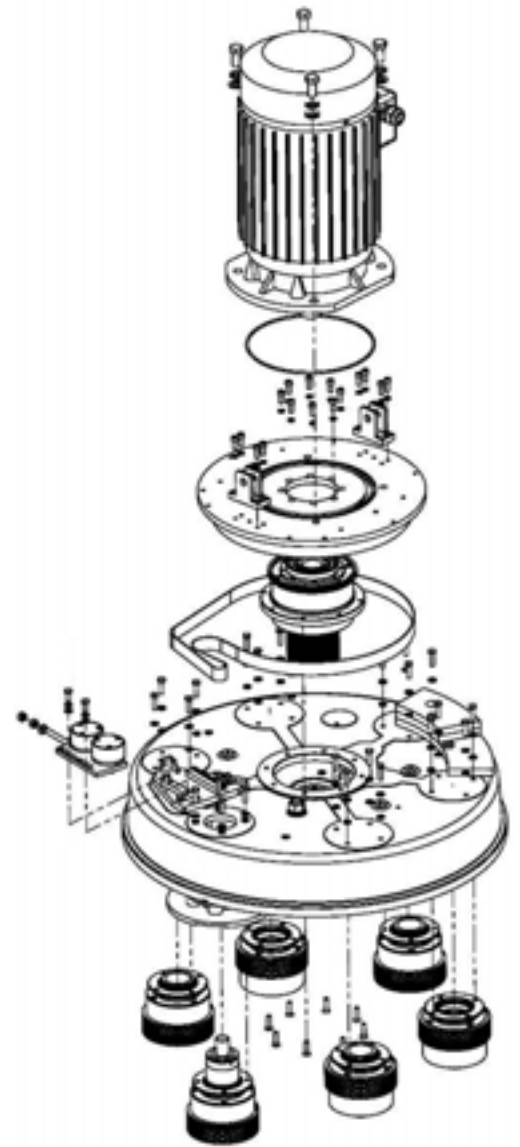

Figure 7.5

CENTRAL SHAFT BEARING EXPLODED VIEW (FIG.7.6)

TOP COVER EXPLODED VIEW (FIG.7.7)

GUARD ASSEMBLY EXPLODED VIEW (FIG.7.8)

CARRIAGE EXPLODED VIEW (FIG.7.9)

STEERING BRACKET EXPLODED VIEW (FIG.7.10)

TOOL HOLDER EXPLODED VIEW (FIG.7.11)



Figure 7.6

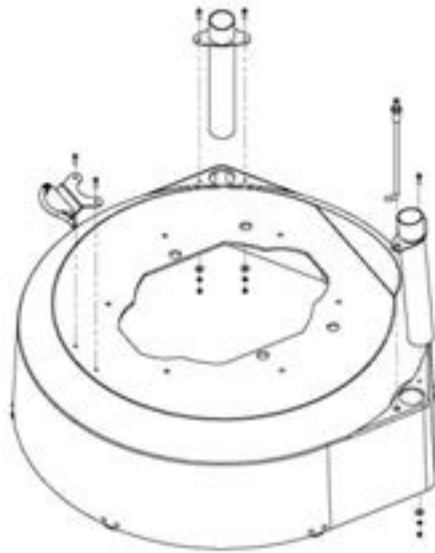

Figure 7.7

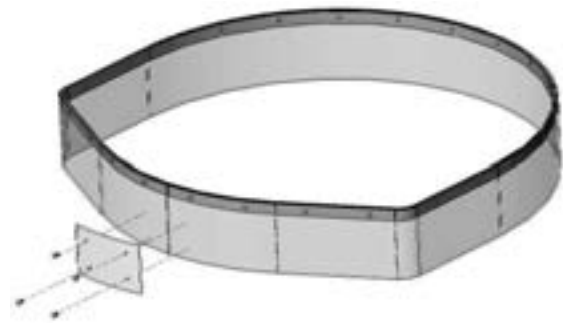

Figure 7.8

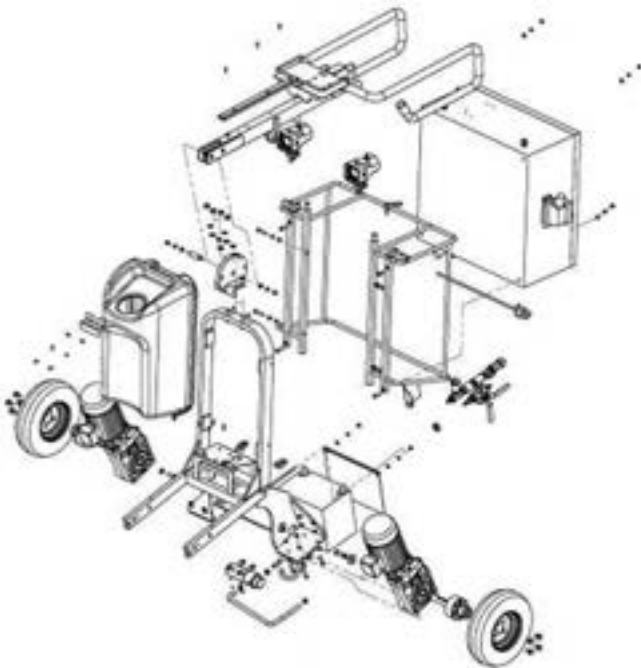

Figure 7.9

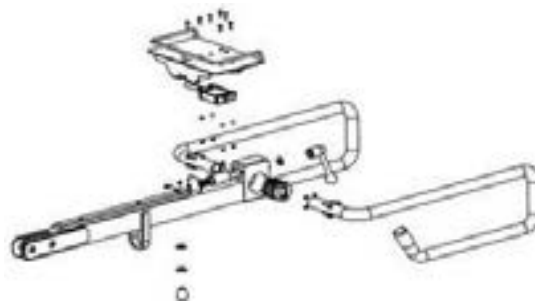

Figure 7.10

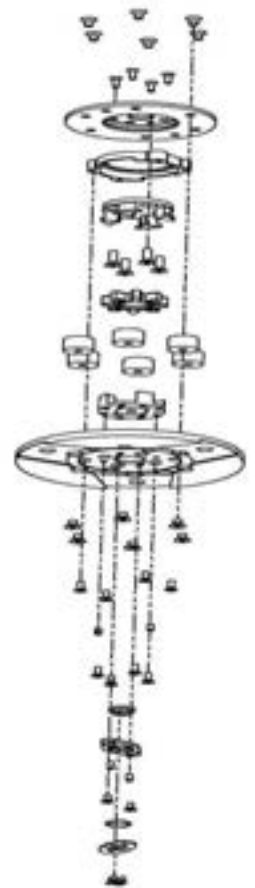

Figure 7.11

8. MAINTENANCE AND INSPECTION

CLEANING

Keep your machine clean. Cleaning the machine on a regular basis will help detect and solve potential problems before they cause damage to the machine. Most importantly, check and clean the tool plate connections, power cord and plugs, vacuum hoses and water tank.

CHECK DAILY

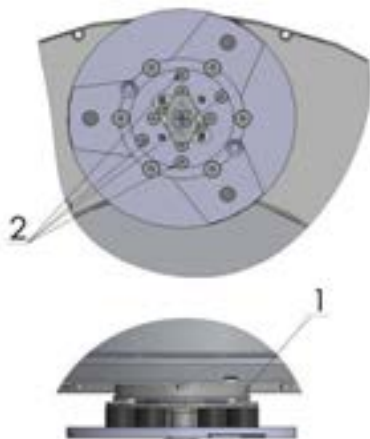

Figure 8.1

After operating the Lavina® 32R-S/32R-S-HV, the operator should conduct a visual inspection of the machine. Any defect should be solved immediately. Pay attention to power cords, plugs and vacuum hoses loose bolt or screws.

Tool holders: Buffers and spiders are consumables and must be visually checked daily and replaced if needed. The key lock holders (butterflies) on the tool holders should be also checked.

Check the rubber buffers and fixing of the holders. The flange holding the buffers (Fig.8.1-1) has to be firmly fixed to the unit. A gap seen there means that there are loose screws fixing the holder. The screws has to be tightened immediately for safety operation. Working with loose screws on the holder could also cause bad damages on the machine. Tightening force of the screws has to be 25...30N.m(18...22 ft/lbs).

It is very important to check regularly the screws (Fig.8.1 2), that fix the "Quickchange" holder to the safety part, so that holder will not fly away if the buffers got damaged.

"Quickchange" should be clean. The tension of the planetary belt can be daily checked by moving the main head and feeling the resistance of the moving pulleys, if the belt slips tighten if necessary, as described in the chapter Troubleshooting .

CHECK AFTER THE FIRST 15 WORKING HOURS

The low cover has a control cover (Fig. 9.4-1) that allows fast and easy control and correction of the belt. It is recommended to check the tension of the belt after the first 15 hours and to tighten if necessary. For the correct tension, see TROUBLESHOOTING "mounting the belt".

CHECK EVERY 200 WORKING HOURS

Every 200 working hours, the operator should inspect all parts of the machine carefully. Most importantly, inspect and clean the tool plate connections, power cord and plugs, vacuum hoses and water tank and filter. Also, check the water flow of the pump. Check the guard assembly. Make certain the wheels are clean and rotate properly. Inspect the control buttons. If there are defective control parts, they should be replaced immediately. Replace worn vacuum- and water hoses. Check the tension of the belt and to tighten if necessary. For the correct tension, see TROUBLE SHOOTING.

Carefully inspect the seal rings and bearings of the grinding units, and replace any showing signs of excessive wear. For more information, refer to chapter troubleshooting below.

CHECK EVERY 400 WORKING HOURS

Besides the checks of 200 working hours, open up the bottom cover like described in chapter "TROUBLE SHOOTING REPLACING BELT TENSIONING. Check if sealers, belt and bearings are in good condition, change if needed. Beware by tensioning the belt not to "over tension"; the belt will never regain his original tension.

VACUUM

As stated previously, frequently check hoses and other parts for clogging.

WATER LEAKS

Replace any leaking parts immediately as the water could damage your machine

ELECTRICAL SYSTEM

Dust should not enter the control box, as it will destroy the contacts. Remove (blow out) any dust present.

MECHANICAL PARTS

Parts such as the belt, seal rings, cap rings, spiders and buffers and guard assembly are subject to wear and should be replaced as needed.

CARRIAGE WHEELS

Check the pressure of the pneumatic tires and maintain it at the limits of 3.5-4 atm/50...60PSI/.

BATTERY OF THE DRIVING

The machine uses maintenance free battery. The battery charges automatically during work. After long transportation on self move the machine should be switched on to the power supply and the power switch BATTERY-LINE to stay on LINE position, in order to recharge the battery. The approximate battery charge level can be checked on the Indicator Lights that is noted in the operating manual of the control box built-in DC-to-AC Inverter/Chargers.

Upon long outage of the machine (more than one week) it is recommended to switch off the battery of the system by the safety switch on the bottom part of the board (Fig.8.2) or to unplug the battery cables.



Figure 8.2

BATTERY OF THE PANEL

The condition of the panel battery is displayed on the right upper corner of the screen. In case the batteries are run down they should be changed or the panel to be connected with the cable (see.Fig.4.8; Fig.4.9; Fig.4.10), then the batteries start to recharge.

LAVINA®32R-S ELECTRICAL SCHEMES WITH YASKAWA INVERTER 200-240 VOLT

Main Circuit

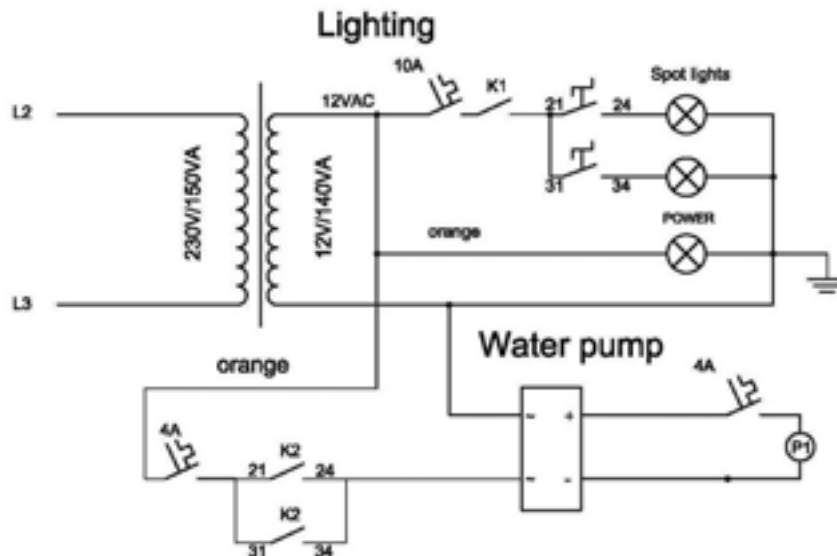
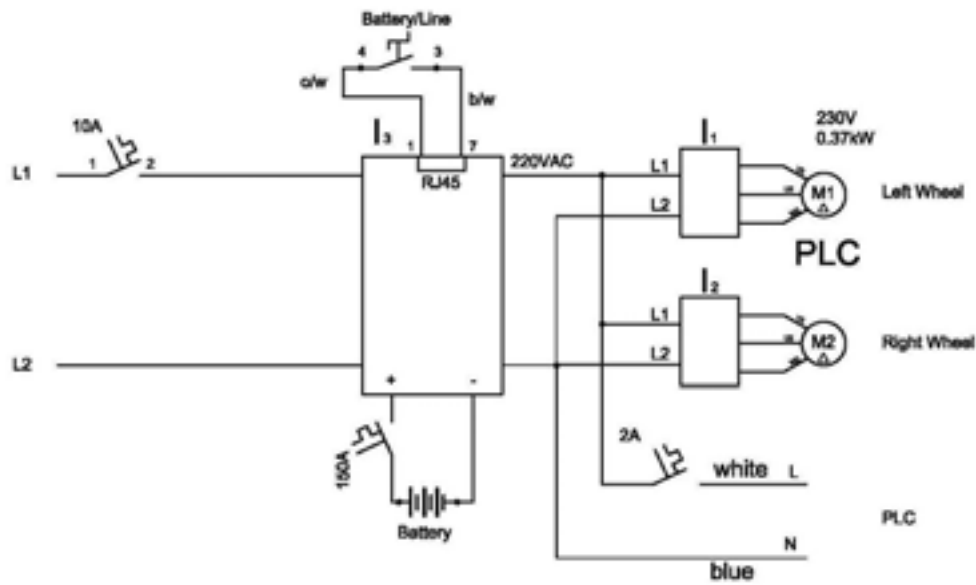
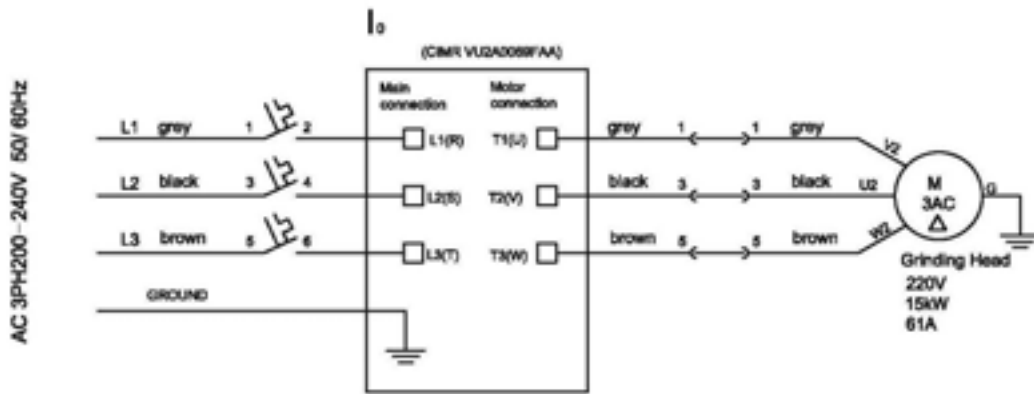

LAVINA®32R-S-HV ELECTRICAL SCHEMES WITH YASKAWA INVERTER 380-480 VOLT

Main Circuit

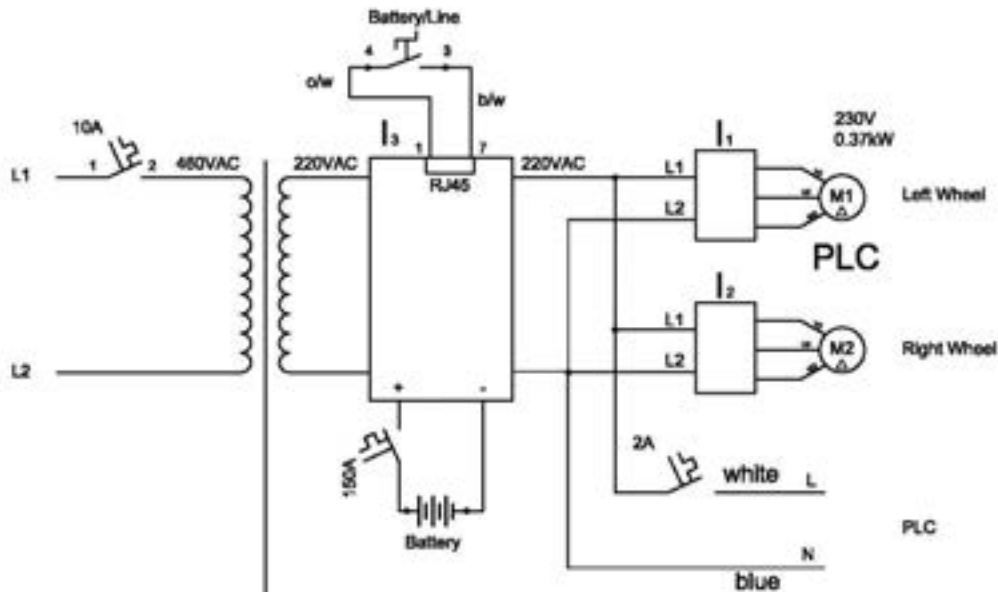
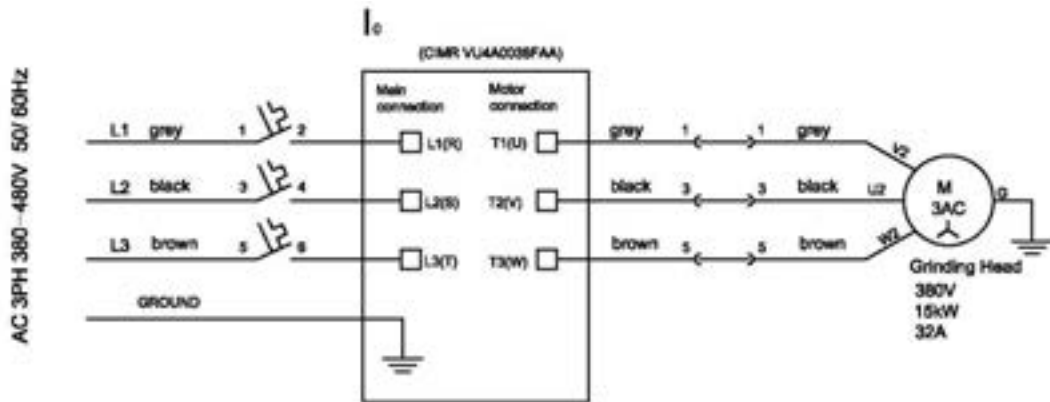

Lighting

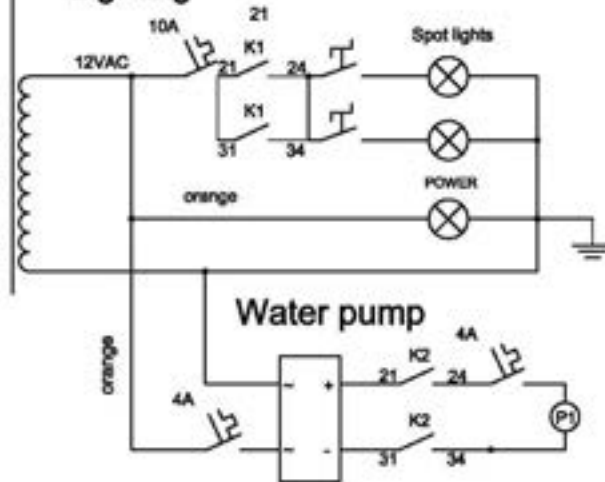

Motion and Grinding Control

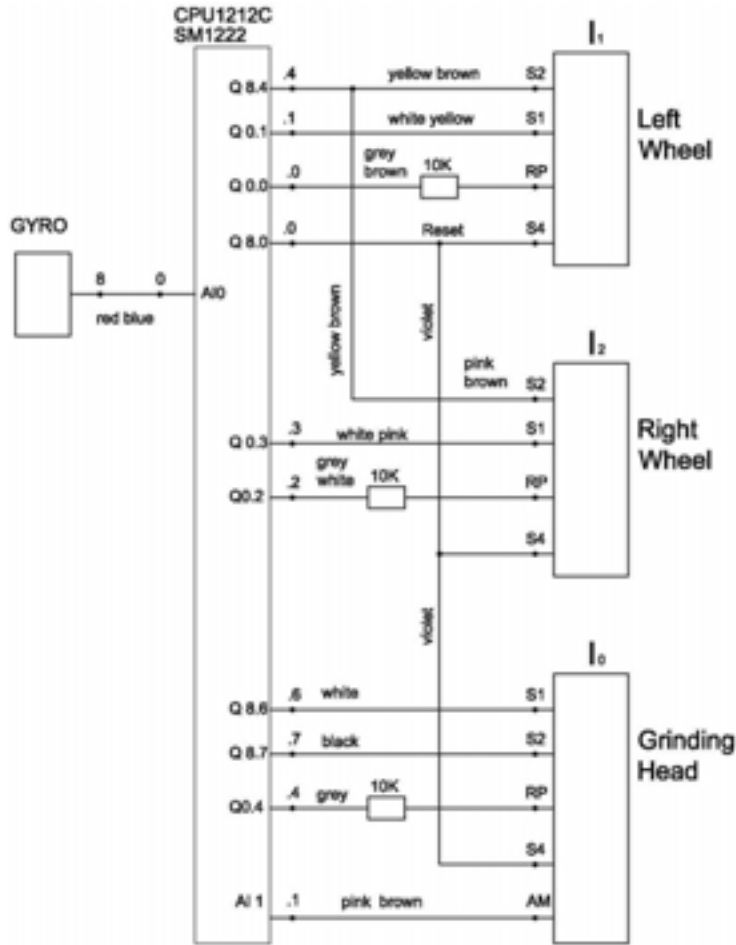

Power Supply

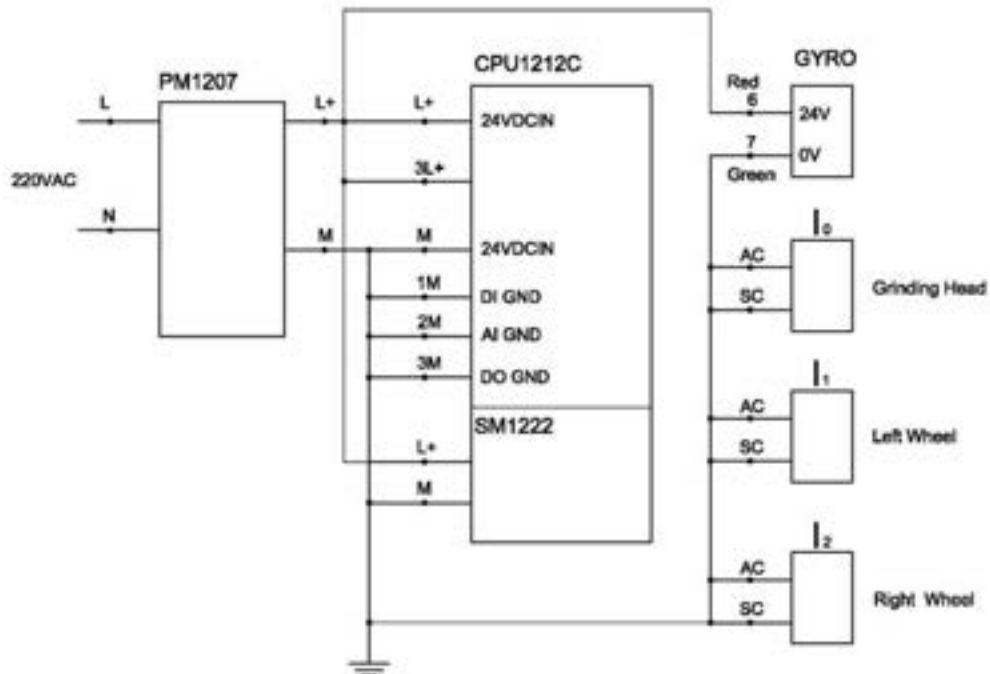

Communication

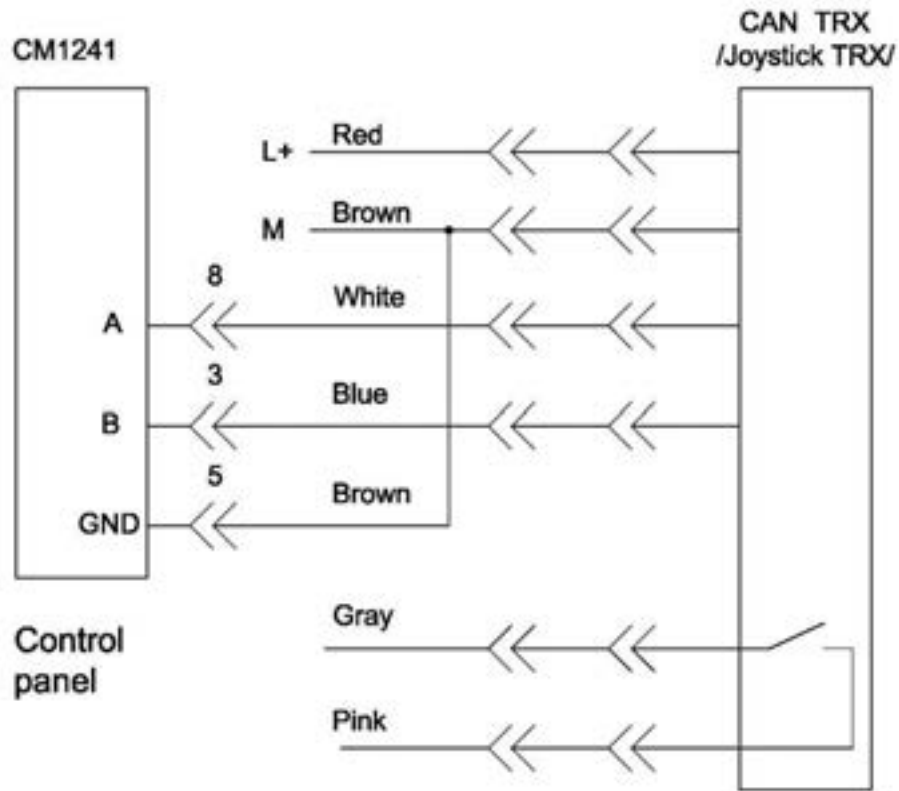

Control panel

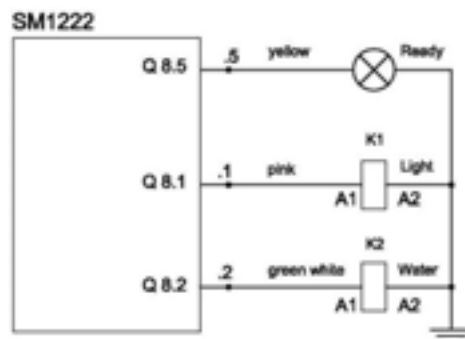
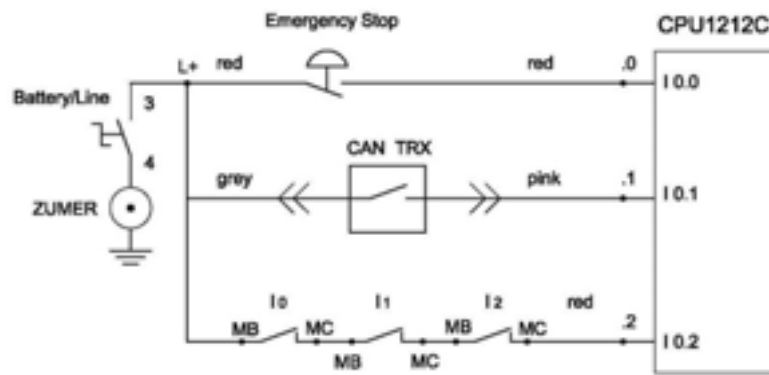

9. TROUBLESHOOTING

INDEX OF PROBLEMS AND SOLUTIONS

9.1 REPLACING POWER CORD AND PLUGS

When replacing the power cord or plugs always use cords and plugs with specifications as the original ones. Never use lower quality or different type cord and plugs.

9.2 DISMOUNTING AND MOUNTING TOOL HOLDER

TO CHANGE BUFFERS AND SPIDERS, CHANGING V-RINGS AND FELT-RINGS



Figure 9.2.1



Figure 9.2.2



Figure 9.2.3



Figure 9.2.4



Figure 9.2.5



Figure 9.2.6

To check or replace the buffers and the spiders, the tool holders have to be dismantled. Remove the countersunk screws on top of the buffer (Fig.9.2.1). Take the disc off (Fig.9.2.2), the spider can be removed or replaced (Fig.9.2.3). By loosening four Hex cap bolts (Fig.9.2.4), the disc comes loose (Fig.9.2.5) and the buffers can be replaced (Fig.9.2.6). Attention, by mounting use always the "blue" thread locking adhesive, except on the bolts to lock the buffers (Fig.9.2.5). Use always original bolts.

Depending on the number (3,4 or 6) of buffers, the holder can be more flexible or rigid.



Figure 9.2.7



Figure 9.2.8



Figure 9.2.9

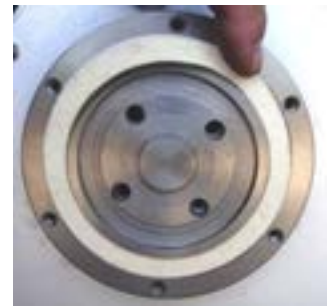

Figure 9.2.10

When the tool holder is dismantled, you can change the sealers (V-Ring and Felt-Ring). Take out Felt-Ring, Adaptor and V-Ring. Before mounting check on which side the adaptor is fitting, remember the correct side. Mount the V-Ring with the smallest lip of the V to inside (Fig.9.2.7) just push the V-ring so the top is on the same level as the pulley top (Fig.9.2.8). Then take the adaptor in the correct way and push the V-Ring down with the adaptor (Fig.9.2.9). The lowest lip of the V-Ring should only barely touch its gliding surface; also never push the V-Ring down with fingers. Mount now the Felt-ring on top (Fig.9.2.10). Close the sealers with the cap (Fig.9.2.11).



Figure 9.2.11

9.3 TENSIONING USED PLANETARY BELT

Take the main head of the carriage, like described in the paragraph “Splitting the carriage from the main head”, Dismount the top cover.

Noticing speed lost in planetary movement it is possible to tension the belt for planetary movement as described in 9.4 Mounting and tensioning a new planetary belt.

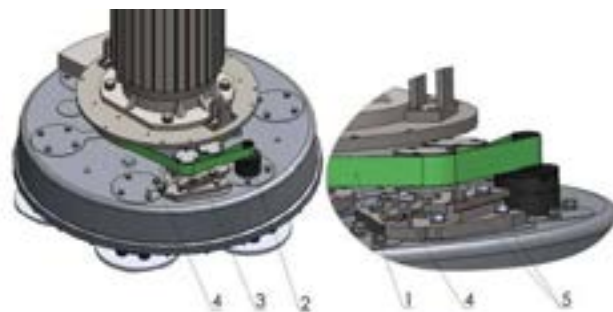

Figure 9.3

9.4 MOUNTING AND TENSIONING A NEW PLANETARY BELT

Dismount completely the tensioning device.

Make 2 signs on the dismounted belt exactly 10 cm out of each other (belt without tension) (Fig.9.4.1). The purpose is to measure 10.2 cm on the belt in tension what is a tension of 2%., a maximum of 2.5% is allowed.

ATTENTION: NEVER “OVER” TENSION THE BELT, THE BELT WILL BE DAMAGED AND IT WILL NEVER RECOVER ITS ORIGINAL TENSION

Mount the belt back around the planetary pulley; see that the belt is behind the driving pulley (Fig.9.4.2). Put the belt around the left roller of the tensioning device (Fig.9.4.3). Put the tensioning device back in place and pull the belt from the roller on the right side (Fig.9.4.4). Put the belt around the driving pulley (Fig.9.4.5).

Loose slightly the two bolts of the tensioning device (Fig.9.4.6) (Fig.9.4.7).Begin to tension until the measure of 10 cm between the marks becomes 10.2 cm (Fig.9.4.9). Tighten the tensioning device while turning the bolt move the planetary head so the belt can slide. (Fig.9.4.9). Do not forget to lock the tensioning device.



Figure 9.4.2



Figure 9.4.3



Figure 9.4.4



Figure 9.4.5



Figure 9.4.6



Figure 9.4.7



Figure 9.4.8



Figure 9.4.9



Figure 9.4.10

9.5 TENSIONING AND REPLACING THE BELTS

PLEASE MAKE SURE YOU CHECK THE TENSION OF THE BELT AFTER THE FIRST 15 HOURS OF OPERATION



Figure 9.5.1



Figure 9.5.2



Figure 9.5.3

To tension or check the tension of the belts. Open the small bottom cover (Fig. 9.5.1). Check the two belts tension, it is recommended

to use an OPTIKRIK II device (Fig. 9.5.4). The Static Belt tension should be proximally 1150 N, A new belt 1450 N.

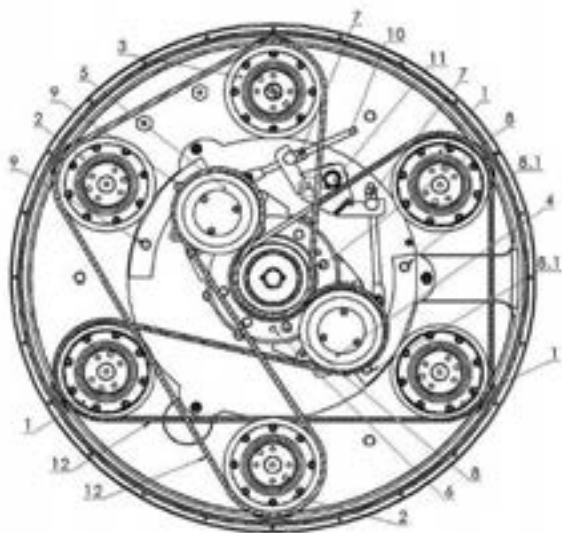

Figure 9.5.4

To change the tension, turn loose the bolt (Fig. 9.5.4 11) on top of the puller, LOOSE THE 5 BOLTS in the middle (fig. Fig. 9.5.4 8) loose also on the half moons the bolts (Fig. 9.5.4-8.1 and Fig. Fig. 9.5.4-9).

Turn loose the secure nut on both forks (Fig. Fig. 9.5.4 7), begin to tension with inner nut work similar on both belts (Fig. 9.5.3).

After matching the right tension secure all previous bolts.

When replacing the belts, take off the tool holder and remove the bottom cover. Un-tension completely. Replace the belts, put them on the right place in the grooves. Use (Fig. 9.5.4) and pull them at last over the tension rollers (Fig. 9.5.4-4, 9.5.4-5). Tension as earlier described.

SQUEALING NOISE If a squealing noise of the belt is heard, it means the belt is not perpendicular with the pulleys. By tension the belt avoid to loose the bolts too much so the pulleys are staying in an exact vertical position.

9.6 REPLACING THE PULLEYS

Take the belt tension away (see the previous paragraph). After removing the belts, unscrew the four bolts of the pulleys on top of the disc (Fig. 9.6- 1).

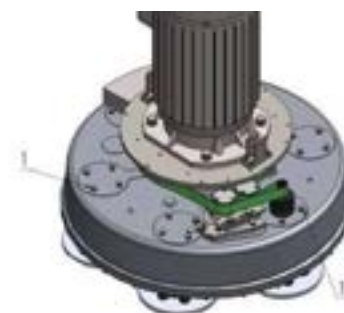

Figure 9.6

9.7 REPLACING THE WHEEL

Lift the lorry on the side you need to change the wheel and place an wooden part so the wheel is on the air. Unscrew the four bolts and take the wheel.



Figure 9.7



Figure 9.8



Figure 9.9

9.8 REPLACING THE BATTERY



Figure 9.10



Figure 9.11



Figure 9.12

9.9 MOTOR CONNECTION

In case of changing the motor, please check the cable connection to your motor.

Lavina® 32R-S

The motor is connected in "Delta" (Triangle) 230 Volt, reminder for the wire connection of the motor.

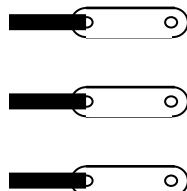

Figure 9.13

Lavina® 32R-S-HV

The motor is connected in "Star" 380 Volt, reminder for the wire connection of the motor.

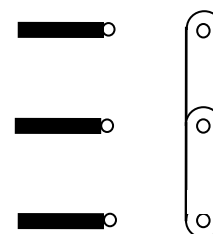

Figure 9.14

FAULT LIST LAVINA® 32R-S

Fault	Additional conditions	Cause	Action
The display does not work	Push emergency stop button	Panel turned off	Release the emergency stop button clockwise
	The panel is not connected to the machine with a cable	No battery . Batteries are not put correctly.	Put charged batteries in the panel or connect it with a cable
The display of the panel lights and then turns off	Discharged batteries indicator is on	Discharged batteries	Put charged batteries in the panel or connect it with a cable
No connection with the machine. Connection indicator shows no connection	Switch „Battery/Network“ is in condition “Battery” . The „Ready“ light is off.	Lack of battery, damaged battery or discharged battery.	Switch „Battery/Network“ to „Network“ . Check connection and battery condition.
	Switch „Battery/Network“ is in “Network” position. The „Ready“ light is off. The “Power” light is off.	No power supply in the network. Unplugged or damaged feeding cable.	Check for power supply. Check and if necessary change the cable.
The machine does not fulfill commands	Light „Ready“ flashes. Indication „Emergency Stop”	Emergency stop is pushed.	Release the emergency stop.
	Light „Ready“ flashes. Indication „Inverter Fault”	Protection on into inverter I1,I2 or I3	Slow down the rev . Switch „Reset Inverter”
The main motor does not start.	Switch „Battery/Network“ is in “Battery” position. The „Ready“ light is on. The “Power” light is off.	The machine is not power supplied.	Switch „Battery/Network“ in position „Network“ . Plug the feeding cable in the circuit.
Upon command „forward“ или „backward“ the machine turns one side.	After a while the machine stops and an indication shows „Inverter Fault”	Overloaded inverter for movement .	Switch „Reset Inverter”
No water feed.	Main motor is not on.	Condition for water supply	Turn on the main motor

FAULT DIAGNOSIS INVERTER YASKAWA V1000

Pages are referring to

Yaskawa Electric SIEP C710606 18A YASKAWA AC Drive – V1000 Technical Manual

◆ Types of Alarms, Faults, and Errors

Check the LED operator for information about possible faults if the drive or motor fails to operate. *Refer to Using the Digital LED Operator on page 70.*

If problems occur that are not covered in this manual, contact the nearest Yaskawa representative with the following information:

- Drive model
- Software version
- Date of purchase
- Description of the problem

Table 6.4 contains descriptions of the various types of alarms, faults, and errors that may occur while operating the drive. Contact Yaskawa in the event of drive failure.

Table 6.4 Types of Alarms, Faults, and Errors

Type	Drive Responses to Alarms, Faults, and Errors
Faults	<p>When the drive detects a fault:</p> <ul style="list-style-type: none"> • The digital operator displays text that indicates the specific fault and the ALM indicator LED remains lit until the fault is reset. • The fault interrupts drive output and the motor coasts to a stop. • Depending on the setting, the drive and motor may stop via different methods than listed. • If a digital output is programmed for fault output (H2-□□ = E), it will close if a fault occurs. • When the drive detects a fault, it will remain inoperable until that fault has been reset. <i>Refer to Fault Reset Methods on page 264.</i>
Minor Faults and Alarms	<p>When the drive detects an alarm or a minor fault:</p> <ul style="list-style-type: none"> • The digital operator displays text that indicates the specific alarm or minor fault and the ALM indicator LED flashes. • The motor does not stop. • One of the multi-function contact outputs closes if set to be tripped by a minor fault (H2-□□ = 10), but not by an alarm. • The digital operator displays text indicating a specific alarm and ALM indicator LED flashes. • Remove the cause of an alarm or minor fault to automatically reset.
Operation Errors	<p>When parameter settings conflict with one another or do not match hardware settings (such as with an option card), it results in an operation error.</p> <p>When the drive detects an operation error:</p> <ul style="list-style-type: none"> • The digital operator displays text that indicates the specific error. • Multi-function contact outputs do not operate. • When the drive detects an operation error, it will not operate the motor until the error has been reset. Correct the settings that caused the operation error to reset.
Tuning Errors	<p>Tuning errors occur while performing Auto-Tuning.</p> <p>When the drive detects a tuning error:</p> <ul style="list-style-type: none"> • The digital operator displays text indicating the specific error. • Multi-function contact outputs do not operate. • Motor coasts to stop. • Remove the cause of the error and repeat the Auto-Tuning process.

◆ Alarm and Error Displays**■ Faults**

When the drive detects a fault, the ALM indicator LEDs remain lit without flashing. If the LEDs flash, the drive has detected a minor fault or alarm. *Refer to Minor Faults and Alarms on page 240* for more information. An overvoltage situation trips both faults and minor faults, therefore it is important to note whether the LEDs remain lit or if the LEDs flash.

LED Operator Display	Name	Page	LED Operator Display	Name	Page
bUS	bUS Option Communication Error	242	CPF08	EEPROM Serial Communications Fault	243
CE	MEMOBUS/Modbus Communication Error	242	CPF11	RAM Fault	243
CF	Control Fault	242	CPF12	FLASH Memory Fault	243
CoF	CoF Current Offset Fault	242	CPF13	Watchdog Circuit Exception	243
CPF02	CPF02 A/D Conversion Error	242	CPF14	Control Circuit Fault	243
CPF03	CPF03 PWM Data Fault	243	CPF16	Clock Fault	243
CPF05	CPF05 Drive specification mismatch during Terminal Board or Control Board replacement	243	CPF17	Timing Fault	243
CPF07	CPF07 Terminal Board Communication Fault	243	CPF18	Control Circuit Fault	243
			CPF19	Control Circuit Fault	244

LED Operator Display	Name	Page	LED Operator Display	Name	Page		
CPF20 or CPF21	RAM Fault	244	GF	Ground Fault	245		
	FLASH Memory Fault	244	LF	Output Phase Loss	245		
	Watchdog Circuit Exception	244	LF2	Output Open Phase	246		
	Clock Fault	244	oC	Overcurrent	246		
oH3	oH3	Motor Overheat 1 (PTC input)	247	oFA00	oFA00	Option Card Fault (port A)	246
oH4	oH4	Motor Overheat 2 (PTC input)	248	oH	oH	Heatsink Overheat	247
oL1	oL1	Motor Overload	248	oH1	oH1	Heatsink Overheat	247
oL2	oL2	Drive Overload	248	PGo	PGo	PG Disconnect (for Simple V/f with PG)	250
oL3	oL3	Overtorque Detection 1	249	rH	rH	Dynamic Braking Resistor	251
oL4	oL4	Overtorque Detection 2	249	rr	rr	Dynamic Braking Transistor	251
oL5	oL5	Mechanical Weakening Detection 1	249	SEr	SEr	Too Many Speed Search Restarts	251
oL7	oL7	High Slip Braking oL	249	STO	STO	Pull-Out Detection	251
oPr	oPr	Operator Connection Fault	249	UL3	UL3	Undertorque Detection 1	251
CPF22	CPF22	A/D Conversion Error	244	UL4	UL4	Undertorque Detection 2	251
CPF23	CPF23	PWM Feedback Data Fault	244	UL5	UL5	Mechanical Weakening Detection 2	251
CPF24	CPF24	Drive Capacity Signal Fault	244	Uv1	Uv1	Undervoltage	252
dEv	dEv	Excessive Speed Deviation (for Simple V/f with PG)	244	Uv2	Uv2	Control Power Supply Undervoltage	252
EF0	EF0	Option Card External Fault	244	Uv3	Uv3	Soft Charge Circuit Fault	252
EF1 to EF7	EF1 to EF7	External Fault (input terminal S1 to S7)	244	oS	oS	Overspeed (for Simple V/f with PG)	249
FbH	FbH	Excessive PID Feedback	245	ov	ov	Overvoltage	249
FbL	FbL	PID Feedback Loss	245	PF	PF	Input Phase Loss	250

Note: If faults CPF11 through CPF19 occur, the LED operator will display CPF00 or CPF11.

■ Minor Faults and Alarms

When a minor fault or alarm occurs, the ALM LED flashes and the text display shows an alarm code. A fault has occurred if the text remains lit and does not flash. *Refer to Alarm Detection on page 253.* An overvoltage situation, for example, can trigger both faults and minor faults. It is therefore important to note whether the LEDs remain lit or if the LEDs flash.

Table 6.5 Minor Fault and Alarm Displays

LED Operator Display	Name	Minor Fault Output (H2-□□ = 10)	Page	
bb	bb	Drive Baseblock	No output	253
bUS	bUS	Option Card Communications Error	YES	253
CALL	CALL	Serial Communication Transmission Error	YES	253
CE	CE	MEMOBUS/Modbus Communication Error	YES	253
CrSt	CrSt	Can Not Reset	YES	253
dEv	dEv	Excessive Speed Deviation (for Simple V/f with PG)	YES	254
dnE	dnE	Drive Disabled	YES	254
EF	EF	Rtn Command Input Error	YES	254
EF0	EF0	Option Card External Fault	YES	254
EF1 to EF7	EF1 to EF7	External Fault (input terminal S1 to S7)	YES	255
FbH	FbH	Excessive PID Feedback	YES	255
FbL	FbL	PID Feedback Loss	YES	255
Hbb	Hbb	Safe Disable Signal Input	YES	255
HbbF	HbbF	Safe Disable Signal Input	YES	255
SE	SE	MEMOBUS/Modbus Test Mode Fault	YES	—
oL5	oL5	Mechanical Weakening Detection 1	YES	249
UL5	UL5	Mechanical Weakening Detection 2	YES	251
dWAL	dWAL	DriveWorksEZ Alarm	YES	244
HCR	HCA	Current Alarm	YES	256
oH	oH	Heatsink Overheat	YES	256
oH2	oH2	Drive Overheat	YES	256
oH3	oH3	Motor Overheat	YES	256
oL3	oL3	Overtorque 1	YES	256
oL4	oL4	Overtorque 2	YES	257
oS	oS	Overspeed (for Simple V/f with PG)	YES	257

LED Operator Display		Name	Minor Fault Output (H2-□□ = 10)	Page
<i>ov</i>	<i>ov</i>	Overvoltage	YES	257
<i>PR55</i>	PASS	MEMOBUS/Modbus Test Mode Complete	No output	257
<i>PGo</i>	PGo	PG Disconnect (for Simple V/f with PG)	YES	257
<i>rUn</i>	rUn	During Run 2, Motor Switch Command Input	YES	258
<i>rUnC</i>	rUnC	Run Command Reset	YES	258
<i>UL3</i>	UL3	Undertorque 1	YES	258
<i>UL4</i>	UL4	Undertorque 2	YES	258
<i>Uv</i>	Uv	Undervoltage	YES	258

■ Operation Errors

Table 6.6 Operation Error Displays

LED Operator Display		Name	Page	LED Operator Display		Name	Page
<i>oPE01</i>	oPE01	Drive Unit Setting Error	259	<i>oPE08</i>	oPE08	Parameter Selection Error	260
<i>oPE02</i>	oPE02	Parameter Setting Range Error	259	<i>oPE09</i>	oPE09	PID Control Selection Error	260
<i>oPE03</i>	oPE03	Multi-Function Input Setting Error	259	<i>oPE10</i>	oPE10	V/f Data Setting Error	261
<i>oPE04</i>	oPE04	Terminal Board Mismatch Error	260	<i>oPE11</i>	oPE11	Carrier Frequency Setting Error	261
<i>oPE05</i>	oPE05	Run Command Selection Error	260	<i>oPE13</i>	oPE13	Pulse Train Monitor Selection Error	261
<i>oPE07</i>	oPE07	Multi-Function Analog Input Selection Error	260				

9. WARRANTY AND RETURNS

Warranty Policy for Lavina® 32R-S/32R-S-HV

If your warranty card is missing, call your local distributor and request a warranty card or visit us at www.superabrasive.com to download one.

The customer is responsible for filling out the card and mailing it to the manufacturer's address indicated on the card. To ensure registration and activation of the warranty coverage, the warranty card must be mailed to the manufacturer within 30 days from date of purchase. Failure to mail the warranty card within 30 days from date of purchase may void the warranty. Make sure you provide the manufacturer with all the information requested, and most importantly with the distributor's name, machine serial number and purchase date

Superabrasive Inc. guarantees that the original purchaser of the Lavina® 32R-S/32R-S-HV machine will be covered against defects in material and workmanship for a period of 2 years from the date of delivery or 500 hours of use whichever comes first.

The following conditions pertain to this warranty:

Applies only to the original owner and it is not transferable.

Machine must not be dismantled and tampered with in any way.

Covered components proven defective will be repaired or replaced at no charge. Covered components include motors, bearings and switches.

This warranty does not apply to any repair arising from misuse, neglect or abuse, or to repair of proprietary parts.

This warranty does not apply to products with aftermarket alterations, changes, or modifications.

This warranty is in lieu of and excludes every condition of warranty not herein expressly set out and all liability for any form of consequential loss or damage is hereby expressly excluded.

This warranty is limited to repair or replacement of covered components and reasonable labor expenses.

All warranty returns must be shipped freight prepaid.

The above warranty conditions may be changed only by Superabrasive. Superabrasive reserves the right to inspect and make a final decision on any machine returned under this warranty. This warranty applies to new, used and demo machines.

Superabrasive does not authorize any person or representative to make any other warranty or to assume for us any liability in connection with the sale and operation of our products.

RETURN POLICY FOR LAVINA® 32R-S/32R-S-HV

Lavina® 32R-S/32R-S-HV machines may be returned, subject to the following terms:

In no case, a machine is to be returned to Superabrasive Inc. for credit or repair without prior authorization. Please contact Superabrasive Inc. or your local distributor for an authorization and issuance of a return authorization number. This number along with the serial number of the machine must be included on all packages and correspondence. Machines returned without prior authorization will remain property of the sender and Superabrasive Inc. will not be responsible for these.

No machines will be credited after 90 days from the date of invoice.

All returns must be shipped freight prepaid. All returns may be exchanged for other equipment or parts of equal dollar value. If machines are not exchanged, they are subject to a fifteen percent (15%) restocking fee.

10. DISPOSAL

If your machine after time is not usable or needs to be replaced, send the machine back to Superabrasive or a local distributor, where a professional disposal complying with the environment laws and directives is guaranteed.

11. MANUFACTURER'S CONTACTS

If you need to contact Superabrasive Inc. with technical support questions, below is the contact information.

Address; 9411 Jackson Trail Road, Hoshton GA 30548, USA

Email: info@superabrasive.us

Tel.: 706 658 1122

Fax: 706 658 0357

Website: www.superabrasive.com

12. SPARE PARTS

ASSEMBLY AND PARTS SPECIFICATIONS

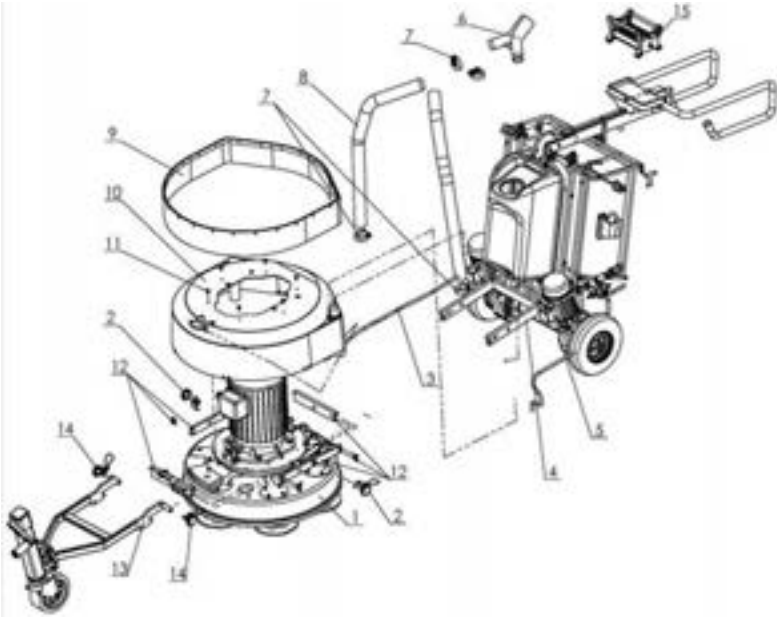

1. LAVINA®32R-S GENERAL PARTS				
Model	No	Item No.	Description	Pc
L32R-S	1	L32S.10.00.00	Disc Assembly	1
L32R-S	2	L32S.05.00.00	Pin Assembly	2
L32R-S	3	MAR 8.152	Tube	1
L32R-S	4	L32R-20.00.00	Carriage	1
L32R-S	5	MAR 8.62	Tube	1
L32R-S	6	L32B-00.00.00.00.01	Air Duct Three-Way	1
L32R-S	7	SGB W1 56-59	Clamp	4
L32R-S	8	d50xL1100	Vacuum Hose	2
L32R-S	9	L32D.02.00.00-01	Guard Assembly	1
L32R-S	10	L32S.01.00.00	Top Cover Assembly	1
L32R-S	11	M8x16 DIN 7380F	Screw	6
L32R-S	12	L32S.03.00.00	U-joint	1
L32R-S	13	L32S-04.00.00	Third wheel	1
L32R-S	14	L32S-04.02.00	Pin Assembly TW L32S	2
L32R-S	15	HATOX Set	Remote Control Set	1

2. LAVINA®32R-S TOOL HOLDER FOR MACHINES PARTS

Model	No.	Item No.	Description	Pcs.
L32R-S	1		LAVINA 32R-S	1
L32R-S	2	A.31.00.00	Holder A31	1

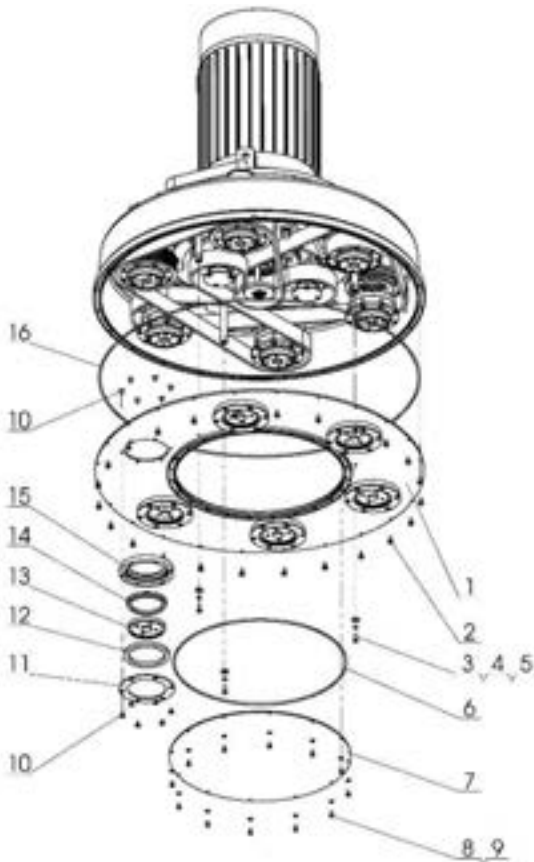
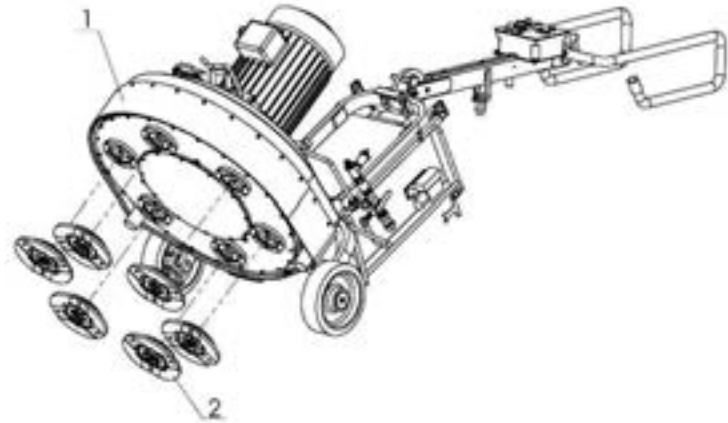

3. LAVINA®32R-S BOTTOM COVER ASSEMBLY PARTS

Model	No.	Item No.	Description	Pcs.
L32R-S	1	L32D.10.02.00	Bottom Cover Ass.	1
L32R-S	2	M5x12 DIN 6921	Bolt	24
L32R-S	3	M6x16 DIN 6921	Bolt	3
L32R-S	4	M6DIN7980	Spring Washer	3
L32R-S	5	M6DIN9021A	Washer	3
L32R-S	6	D4x2-420	Seal	1
L32R-S	7	L32D.10.00.03	Small Bottom Cover	1
L32R-S	8	M5x10 DIN933	Bolt	12
L32R-S	9	M5 DIN 433	Spring Washer	12
L32R-S	10	M6x10 DIN7991	Screw	36
L32R-S	11	L25 LS.14.00.03	Outer Cover	6
L32R-S	12	110x90x8.5	Felt Ring	6
L32R-S	13	A34.00.01	Adaptor	6
L32R-S	14	TWVA00800	V-Ring Type A	6
L32R-S	15	L32S-10.02.02	Flange	6
L32R-S	16	D4x2-2500	Seal	1

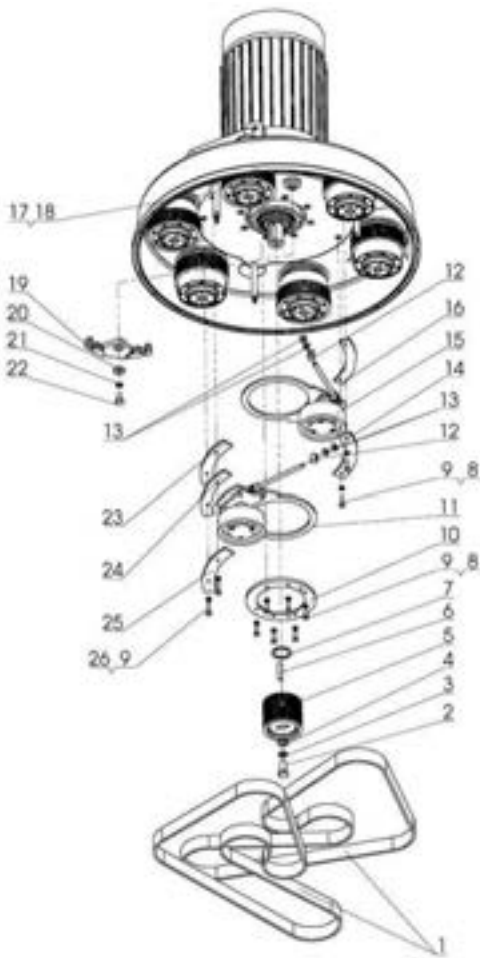

4. LAVINA®32R-S PULLEY UNIT PARTS				
Model	No.	Item No.	Description	Pcs.
L32R-S	1	PL2476/975L9	Endless Transmission V Belt	2
L32R-S	2	M16X35DIN933	Bolt	1
L32R-S	3	M16DIN127B	Spring Washer	1
L32R-S	4	M16DIN125A	Washer	1
L32R-S	5	L32D.10.01.00	Central Pulley	1
L32R-S	6	DIN6885A12x8x56	Key	1
L32R-S	7	L32D.10.00.06	Ring	1
L32R-S	8	M8x25DIN933	Bolt	8
L32R-S	9	M8DIN7980	Spring washer	10
L32R-S	10	L32D.10.00.18	Cap	1
L32R-S	11	L32C.15.00.00	Tension Roller Bottom	1
L32R-S	12	L32C.14.20.04	Spindle	2
L32R-S	13	M10DIN934	Nut	4
L32R-S	14	L32D.10.00.14	Sector 4	1
L32R-S	15	L32C.14.00.00	Tension Roller Top	1
L32R-S	16	L32D.10.00.15	Sector 5	1
L32R-S	17	L32D.10.00.02	Distance Bolt	3
L32R-S	18	D6X2	O-Ring	3
L32R-S	19	L32D16.10.00	Puller	1
L32R-S	20	L32D-16.00.03	Washer	1
L32R-S	21	M12DIN127B	Spring washer	1
L32R-S	22	M12x20DIN933	Bolt	1
L32R-S	23	L32D.10.00.13	Sector 3	1
L32R-S	24	L32D.10.00.11	Sector 1	1
L32R-S	25	L32D.10.00.12	Sector 2	1
L32R-S	26	M8x35DIN		

5. LAVINA®32R-S BOTTOM COVER ASSEMBLY PARTS				
Model	No.	Item No.	Description	Pcs.
L32R-S	1	M16X35DIN933	Bolt	4
L32R-S	2	M16DIN127B	Spring Washer	4
L32R-S	3	M16DIN125A	Washer	4
L32R-S	4	S321	Electro Motor	1
L32R-S	5	M8X20DIN912	Screw	14
L32R-S	6	M8DIN7980	Spring Washer	14
L32R-S	7	L32-01.02.00.00.01	Fork	2
L32R-S	8	L32S.11.00.00	Central shaft bearing	1
L32R-S	8.1	L32S.11.12.00	Disc Assembly with Planetary Pulley	1
L32R-S	9	TC-20 EF L1730x30x2	Endless Transmission Flat Belt	1
L32R-S	10	L32D.12.00.00-02	Pulley Top Belt	2
L32R-S	11	L32D.12.00.00-01	Pulley Bottom Belt	3
L32R-S	12	L32S.13.00.00	Pulley Unit	1
L32R-S	13	L32D.10.00.01	Disc	1
L32R-S	14	L32S.17.00.00	Planetary Tensioning Unit	1
L32R-S	15	D4x2x850	Seal	1
L32R-S	16	M8X30DIN7991	Screw	8

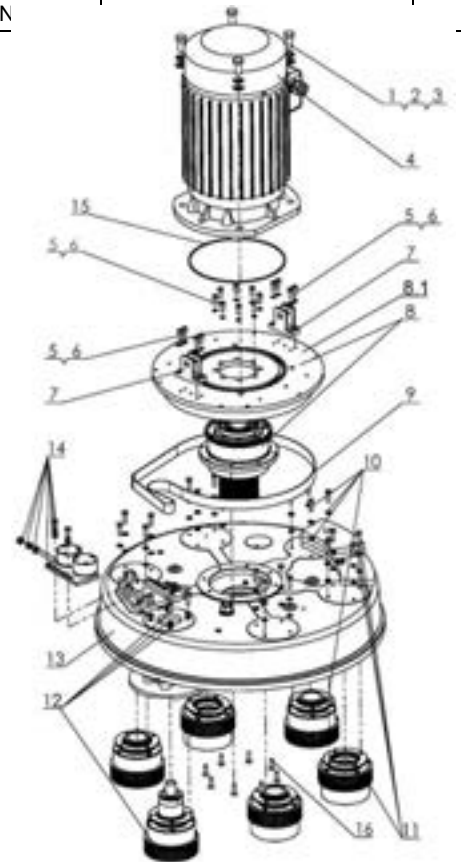

6. LAVINA®32R-S CENTRAL SHAFT BEARING PARTS				
Model	No.	Item No.	Description	Pcs.
L32R-S	1	B65DIN471	Retaining Ring	1
L32R-S	2	6013	Roller Assembly	1
L32R-S	3	L32D.11.00.05	Extension Shaft	1
L32R-S	4	L32S.11.02.00	Disc Assembly	1
L32R-S	5	TWVL01700	V-Seal	1
L32R-S	6	M6x16DIN7991	Screw	6
L32R-S	7	L32D.11.00.03	Cap	1
L32R-S	8	6019	Roller Assembly	2
L32R-S	9	L32D.11.00.04	Spacer	1
L32R-S	10	L32D.11.01.00	Housing	1
L32R-S	11	B95DIN471	Retaining Ring	1
L32R-S	12	3208	Roller Assembly	1
L32R-S	13	A80DIN472	Retaining Ring	1
L32R-S	14	TWVA00950	V-Seal	1
L32R-S	15	L32D.11.00.06	Ring	1
L32R-S	16	L32S.11.00.17	Planetary Pulley	1
L32R-S	17	M8x30 DIN 912	Screw	6

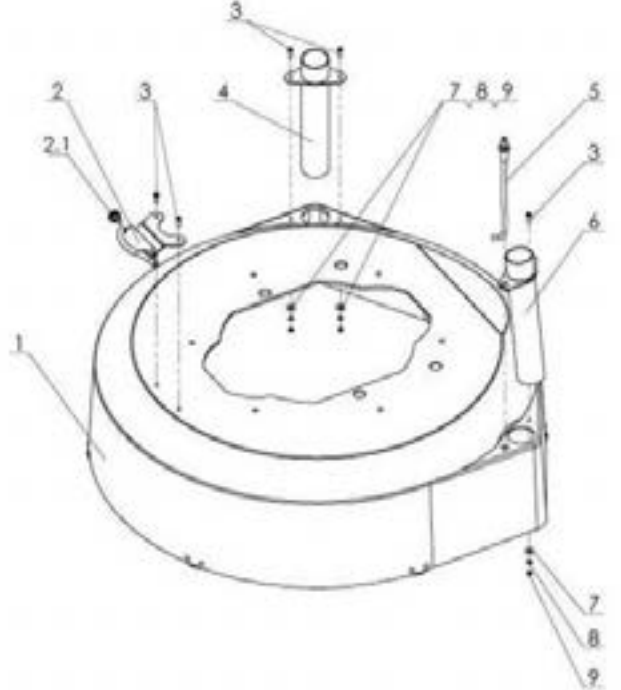

7. LAVINA®32R-S TOP COVER PARTS				
Model	No.	Item No.	Description	Pcs.
L32R-S	1	L32S-01.00.01	Top Cover	1
L32R-S	2	A29-30.00	Spray Unit	1
L32R-S	2.1	H766-21	Knob Bolt	1
L32R-S	3	M5X16DIN84A	Screw	5
L32R-S	4	L32D.01.01.00	Vacuum Port	1
L32R-S	5	L32S-01.20.00	Water Fitting	1
L32R-S	6	L32S.01.01.00	Vacuum Port	1
L32R-S	7	M5 DIN 9021 A	Washer	3
L32R-S	8	M5DIN127B	Spring Washer	3
L32R-S	9	M5DIN934	Nut	3

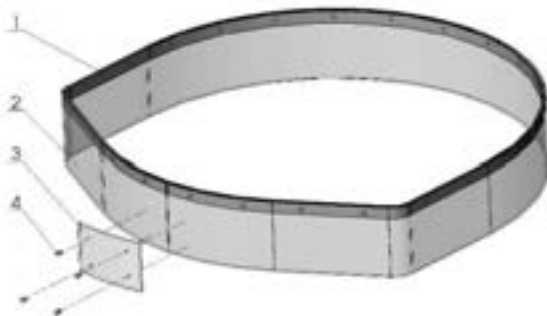

8. LAVINA®32R-S GUARD ASSEMBLY PARTS				
Model	No.	Item No.	Description	Pcs.
L32R-S	1	L32D.02.00.01-01	Ring	1
L32R-S	2	L32D.02.00.02-01	Guard	1
L32R-S	3	L32D.02.00.05	PVC Sheet	1
L32R-S	4	D4X10DIN7337	Rivet	24

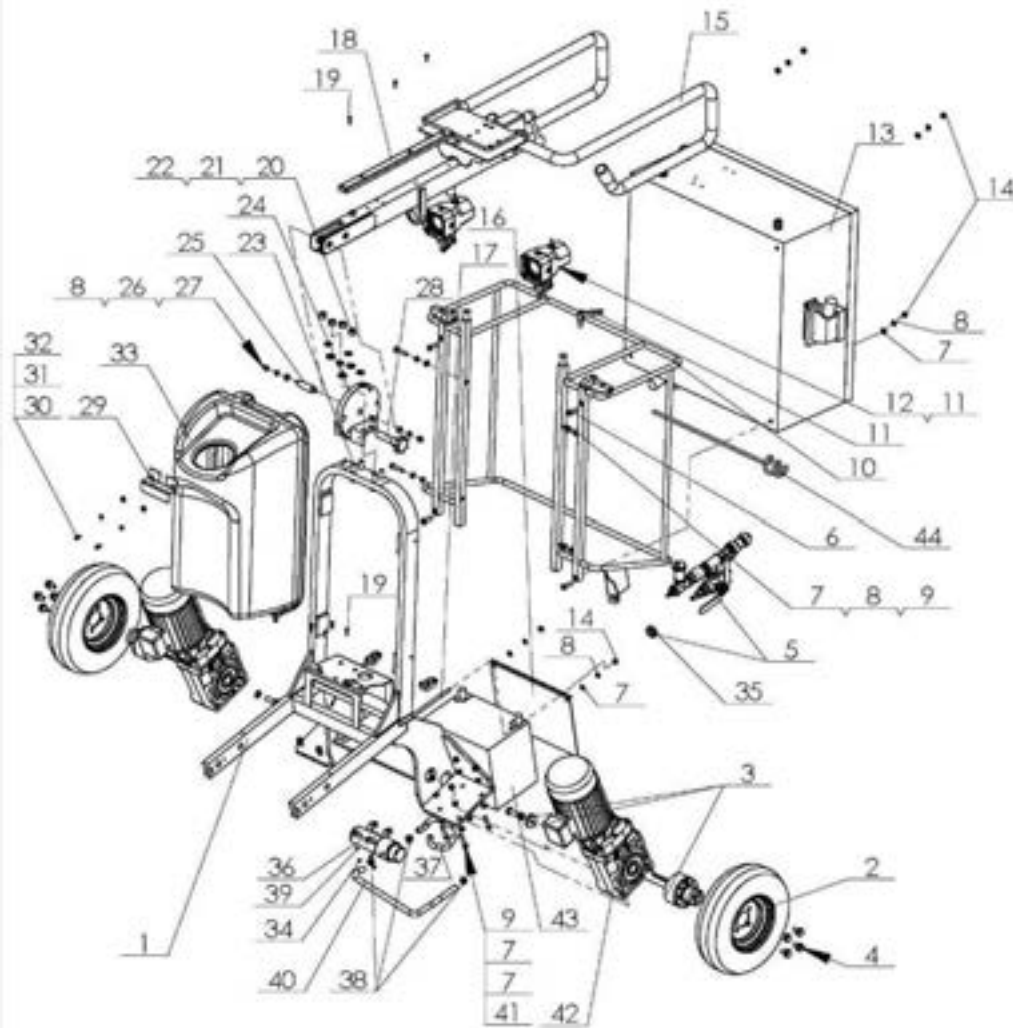

9. LAVINA®32R-S CARRIAGE PARTS

Model	No.	Item No.	Description	Pcs.	No.	Item No.	Description	Pcs.
L32R-S	1	L32R-21.00.00	Frame	1	23	M12x45DIN933	Bolt	4
L32R-S	2	L32R-27.10.00	Wheel assembly	2	24	L32D.22.00.00	Handle Positioner	1
L32R-S	3	L32R-27.30.00	Wheel Bearing	2	25	L32-02.00.00.00.02	Pin	1
L32R-S	4	M10X20DIN6921	Bolt	4	26	M8DIN9021A	Washer	2
L32R-S	5	L32S.20.01.00	Water Connection	1	27	M8DIN1587	Nut	2
L32R-S	6	M8x40 DIN7991	Screw	4	28	L32-02.05.00.00.00	Pin Ass.	1
L32R-S	7	M8 DIN433	Washer	18	29	L32S.20.00.11	Upper Bracket	1
L32R-S	8	M8DIN127B	Spring Washer	12	30	M6DIN125A	Washer	2
L32R-S	9	M8x40 DIN933	Bolt	12	31	M6DIN7980	Spring Washer	2
L32R-S	10	L32R-24.00.00	Guard	1	32	M6x12DIN933	Bolt	2
L32R-S	11	A58165	Swivel Bolt	2	33	A36.00.00	Tank	1
L32R-S	12	L32-02.06.00.00.00	Lamp Unit Incl. Cable	2	34	M5DIN985	Nut	4
L32R-S	13	L32RS-30.00.00	Control Box L32R-S	1	35	M20x1.5DIN439B	Nut	1
L32R-S	13	L32RSHV-30.00.00	Control Box L32R-SHV	1	36	1040	Water Pump	1
L32R-S	14	M8DIN934	Nut	4	37	MAR 8.38	Tube	1
L32R-S	15	L32R-23.00.00	Handle Assembly	1	38	10-16DIN3017	Clamp	3
L32R-S	16	L32R-00.00.42	Battery Guard	1	39	M5DIN9021A	Washer	4
L32R-S	17	L32R-21.00.12	Stud Bolt M8x205	4	40	MAR 8.62	Tube	1
L32R-S	18	L32B-02.03.05.00	Cord Cover	1	41	M8DIN985	Nut	8
L32R-S	19	M5x20DIN7991	Screw	7	42	L32R-27.20.00	Gearmotor	2
L32R-S	20	M12DIN934	Nut	4	43		Battery	1
L32R-S	21	M12DIN127B	Spring Washer	4	44	L32R-20.00.31	Cable Guide	1
L32R-S	22	M12DIN125A	Washer	4				

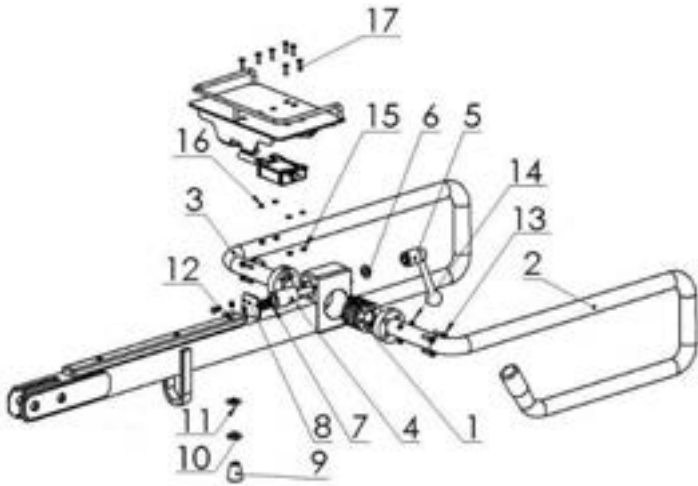

10. LAVINA®32R-S STEERING BRACKET PARTS				
Model	No.	Item No.	Description	Pcs
L32-S	1	L32B-02.03.00.00.01-01	Sprocket	1
L32-S	2	L32B-02.03.02.00.00	Left Bracket	1
L32-S	3	L32B-02.03.03.00.00	Right Bracket	1
L32-S	4	L32C.23.00.06	Screw	1
L32-S	5	GN212.3-28-M12-E	Swivel Bolt	1
L32-S	6	M12DIN125A	Washer	1
L32-S	7	L32B-02.03.00.00.02	Spring	1
L32-S	8	L32C.23.00.21	Housing	1
L32-S	9	BO751-107-25M08	Knob	1
L32-S	10	L32-02.03.00.00.01	Washer	1
L32-S	11	L32-02.03.00.00.02	Teflon Washer	1
L32-S	12	M6X16DIN933	Bolt	2
L32-S	13	M6X25DIN912	Screw	8
L32-S	14	M6DIN7980	Spring Washer	10
L32-S	15	M5DIN985	Nut	4
L32-S	16	M5DIN125A	Washer	4
L32-S	17	M5x20DIN7991	Screw	7

11. LAVINA®32R-S WATER SUPPLY PARTS				
Model	No.	Item No.	Description	Pcs.
L32-S	1	A29.21.00	Backflow Preventer	1
L32-S	2	A29.22.00	Vent Valve	1

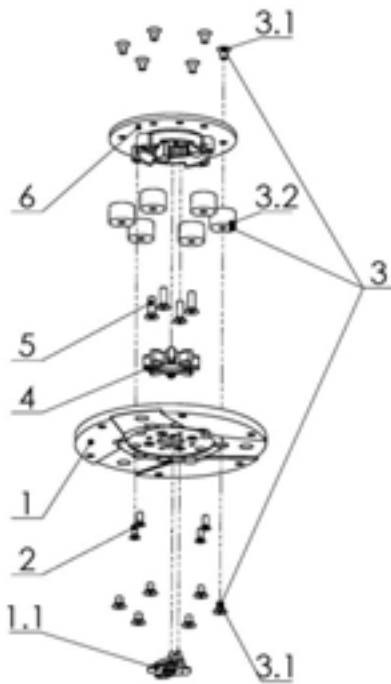
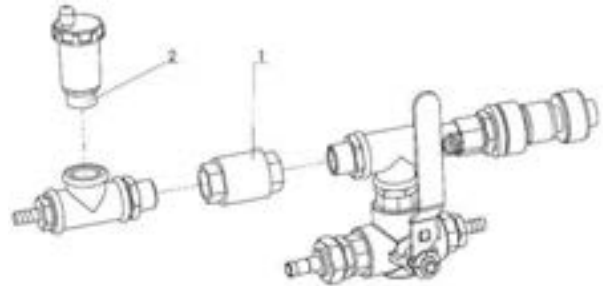

12. LAVINA®32R-S TOOL HOLDER PARTS				
Model	No.	Item No.	Description	Pcs.
L32R-S	1	A31.10.00	Quick Change Assembly	1
L32R-S	1.1	A31.12.00	Keylock Set	1
L32R-S	2	M6X16DIN7991	Screw	4
L32R-S	3	A25.00.10-K	Buffer with two screw	6
L32R-S	3.1	M8X12DIN7991	Screw	12
L32R-S	3.2	A25.00.10	Buffer	6
L32R-S	4	A25.00.05-02	Spider	1
L32R-S	5	M8X25DIN7991-10.9	Screw	4
L32R-S	6	A31.20.00	Flange	1

13. LAVINA®32R-S MOTOR FAN PARTS				
Model	No.	Item No.	Description	Pcs.
L32-S	1	L32DS.10.00.48.01	Fan Cover	1
L32-S	2	L32DS.10.00.48.02	Fan	1
L32-S	3	M8DIN582	Eye Bolt Ring	2
L32-S	4	M8X60DIN939	Stud	2
L32-S	5	M8DIN934	Nut	2
L32-S	6	M8DIN7980	Spring Washer	2
L32-S	7	M5DIN7985A	Screw	4

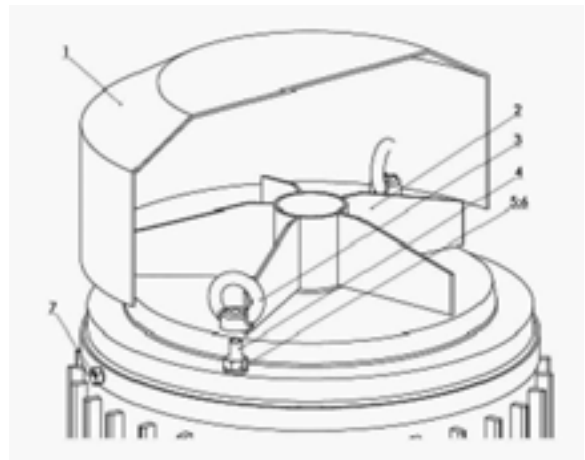

14. LAVINA® 32R-S CONTROL BOX PARTS 200-240 VOLT

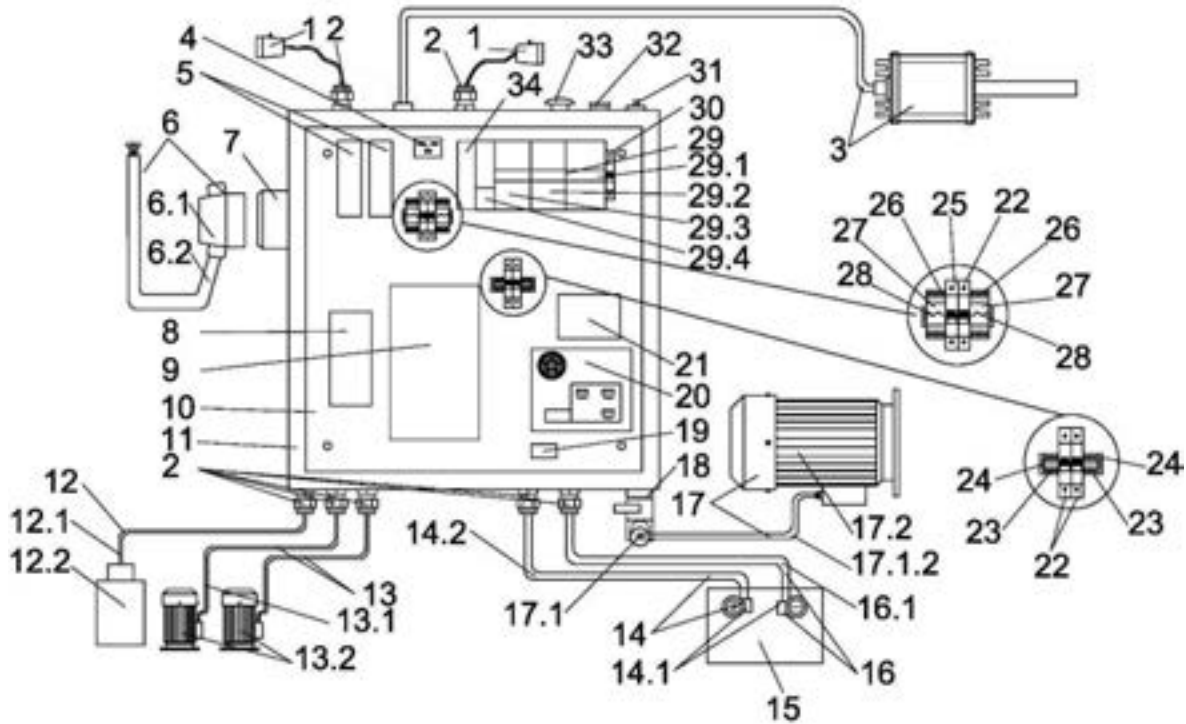

LAVINA® 32R-S CONTROL BOX PARTS 200-240 VOLT								
Model	No.	Item No.	Description	Pcs.	No.	Item No.	Description	Pcs.
L32R-S	1	L20NS-30.30.00	Lamp Unit Incl. Cable	2	17	L32S-30.20.00	Electro Motor Assembly	1
L32R-S	2	L20NS-30.10.01	Cable Gland	7	17.1	L32S-30.20.10	Plug assembly/motor/	1
L32R-S	3	HATOX set	Remote control set	1	17.1.2	L32S-30.20.12	Cable for Electro Motor	1
L32R-S	4	L20NS-30.11.08	Rectifier	1	17.2	S321	Electro Motor	1
L32R-S	5	L32R-S-HV-30.00.02	Frequency Regulator	2	18	L32S-30.19.00	Panel socket ass./motor/F	1
L32R-S	6	L32S-30.70.00	Cable with Connector and Plug	1	19	L32R-S-HV-30.00.05	Automatic Switch 12V 150A	1
L32R-S	6.1	L32S-30.70.10	Connector Ass. /female/	1	20	L32R-S-HV-30.00.06	Inverter with Load Module	1
L32R-S	6.2	L32S-30.70.20	Cable	1	21	L32S-30.11.07	Transformer	1
L32R-S	7	L32S-30.60.00	Plug on Control Board/male/	1	22	L20NS-30.11.01	Automatic Switch 1P/C4	3
L32R-S	8	L32S -30.11.15	Circuit Breaker	1	23	L32R-S-HV-30.00.09	Terminal Clip	10
L32R-S	9	L32S-30.11.21	Inverter Yaskawa (V1000)	1	24	L20NS-30.11.02	DIN Rail	
L32R-S	10	L32R-S-30.00.03	Metal box plate	1	25	L32SHV-30.11.01	Automatic Switch 1P/C10	1
L32R-S	11	L32R-S-30.00.04	Metal box	1	26	L20NS-30.11.04	Rail Base	2
L32R-S	12	L20NS-30.40.00	Water Pump with Cable	1	27	L32RS-30.11.05	Rail	2
L32R-S	12.1	L20NS-30.40.01	Cable for Water Pump	1	28	L20NS-30.11.06	Rail Bracket	2
L32R-S	12.2	1040	Water Pump	1	29	L32R-S-HV-30.29.00	PLC	1
L32R-S	13	L32R-S-HV-30.13.00	Electro motor with cable	2	29.1	L32R-S-HV-30.29.10	Power Supply	1
L32R-S	13.1	L32R-S-HV-30.13.10	Cable 4x1	2	29.2	L32R-S-HV-30.29.20	8 Digite Outputs	1
L32R-S	13.2	L32R-S-HV-30.13.20	Electro Motor	2	29.3	L32R-S-HV-30.29.30	Processor	1
L32R-S	14	L32R-S-HV-30.14.00	Plus Terminal and Battery Cable	1	29.4	L32R-S-HV-30.29.40	Communication Module	1
L32R-S	14.1	L32R-S-HV-30.14.10	Battery –terminal Clip	2	30	L32R-S-HV-30.00.11	Automatic Switch 2A	1
L32R-S	14.2	L32R-S-HV-30.14.20	Plus Battery Cable	1	31	L20NS-30.10.13	Switch ON/OFF/	1
L32R-S	15	L32R-S-30.00.15	Battery	1	32	L20NS-30.10.12	LED /green/	1
L32R-S	16	L32R-S-HV-30.16.00	Minus Terminal and Battery Cable	1	33	L20NS-30.10.10	Emergency Stop Button	1
L32R-S	16.1	L32R-S-HV-30.16.10	Minus Cable for Battery	1	34	GY001	Gyro	1

15. LAVINA® 32R-S-HV CONTROL BOX PARTS 380-480 VOLT

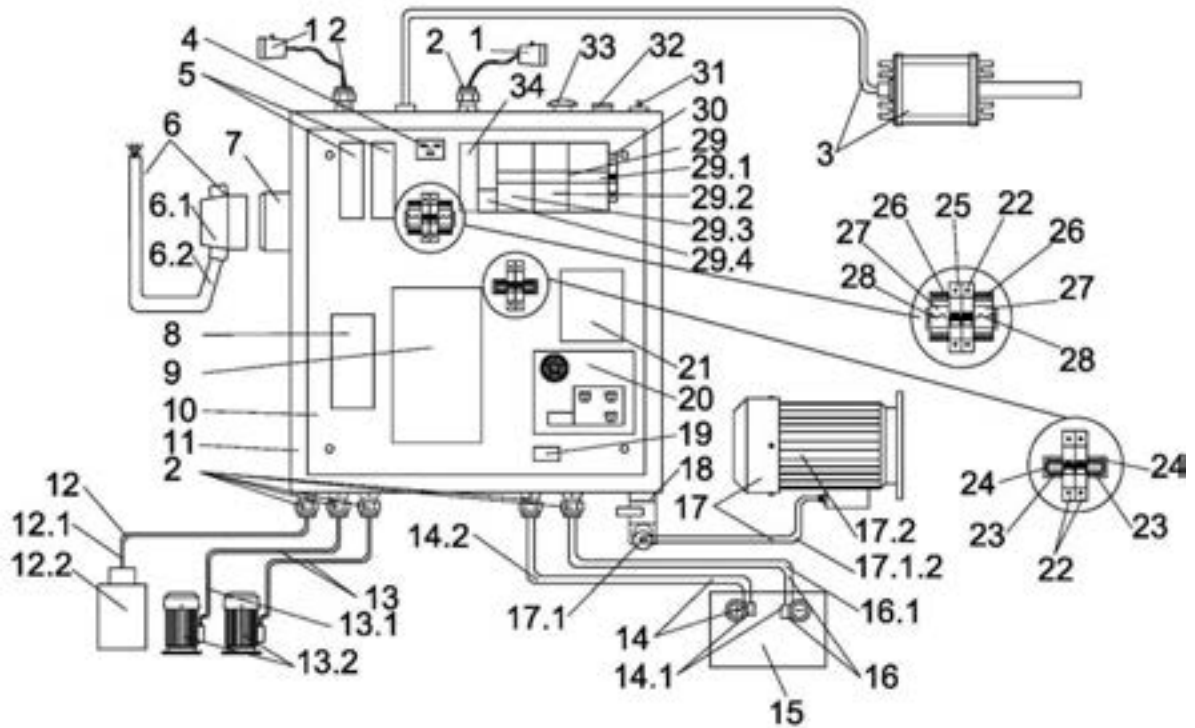

LAVINA®32R-S -HV CONTROL BOX PARTS 380-480 VOLT								
Model	No.	Item No.	Description	Pcs.	No.	Item No.	Description	Pcs.
L32R-S-HV	1	L20NS-30.30.00	Lamp Unit Incl. Cable	2	17	L32SHV-30.20.00	Electro Motor Assembly	1
L32R-S-HV	2	L20NS-30.10.01	Cable Gland	7	17.1	L32SHV-30.20.10	Plug assembly/motor/	1
L32R-S-HV	3	HATOX set	Remote control set	1	17.1 .2	L32SHV-30.20.12	Cable for Electro Motor	1
L32R-S-HV	4	L20NS-30.11.08	Rectifier	1	17.2	S321	Electro Motor	1
L32R-S-HV	5	L32R-S-HV-30.00.02	Frequency Regulator /Inverter Yaskawa/	1	18	L32SHV-30.19.00	Panel socket ass./motor/F	1
L32R-S-HV	6	L32SHV-30.70.00	Cable with Connector and Plug	1	19	L32R-S-HV-30.00.05	Automatic Switch 12V 150A	1
L32R-S-HV	6.1	L32SHV-30.70.10	Connector Ass. /female/	1	20	L32R-S-HV-30.00.06	Inverter with Load Module	1
L32R-S-HV	6.2	L32SHV-30.70.20	Cable	1	21	L32R-S-HV-30.00.07	Transformer	1
L32R-S-HV	7	L32SHV-30.60.00	Plug on Control Board /male/	1	22	L20NS-30.11.01	Automatic Switch 1P/C4	3
L32R-S-HV	8	L32SHV -30.11.15	Circuit Breaker	1	23	L32R-S-HV-30.00.09	Terminal Clip	10
L32R-S-HV	9	L32SHV-30.11.21	Inverter Yaskawa (V1000)	1	24	L20NS-30.11.02	DIN Rail	
L32R-S-HV	10	L32R-S-HV-30.00.03	Metal box plate	1	25	L32SHV-30.11.01	Automatic Switch 1P/C10	1
L32R-S-HV	11	L32R-S-HV-30.00.04	Metal box	1	26	L20NS-30.11.04	Rail Base	2
L32R-S-HV	12	L20NS-30.40.00	Water Pump with Cable	1	27	L32RS-30.11.05	Rail	2
L32R-S-HV	12.1	L20NS-30.40.01	Cable for Water Pump	1	28	L25NS-30.11.06	Rail Bracket	2
L32R-S-HV	12.2	1040	Water Pump	1	29	L32R-S-HV-30.29.00	PLC	1
L32R-S-HV	13	L32R-S-HV-30.13.00	Electro motor with cable	2	29.1	L32R-S-HV-30.29.10	Power Unit	1
L32R-S-HV	13.1	L32R-S-HV-30.13.10	Cable 4x1	2	29.2	L32R-S-HV-30.29.20	Module with 8 Digite Outputs	1
L32R-S-HV	13.2	L32R-S-HV-30.13.20	Electro Motor	2	29.3	L32R-S-HV-30.29.30	Processor	1
L32R-S-HV	14	L32R-S-HV-30.14.00	Plus Terminal and Battery Cable	1	29.4	L32R-S-HV-30.29.40	Communication Module	1
L32R-S-HV	14.1	L32R-S-HV-30.14.10	Battery –terminal Clip	2	30	L32R-S-HV-30.00.11	Automatic Switch 2A	1
L32R-S-HV	14.2	L32R-S-HV-30.14.20	Plus Battery Cable	1	31	L20NS-30.10.13	Switch ON/OFF/	1
L32R-S-HV	15	L32R-S-30.00.15	Battery	1	32	L20NS-30.10.12	LED /green/	1
L32R-S-HV	16	L32R-S-HV-30.16.00	Minus Terminal and Battery Cable	1	33	L20NS-30.10.10	Emergency Stop Button	1
L32R-S-HV	16.1	L32R-S-HV-30.16.10	Minus Cable for Battery	1	34	GY001	Gyro	1