

USER'S MANUAL

Revision: 0

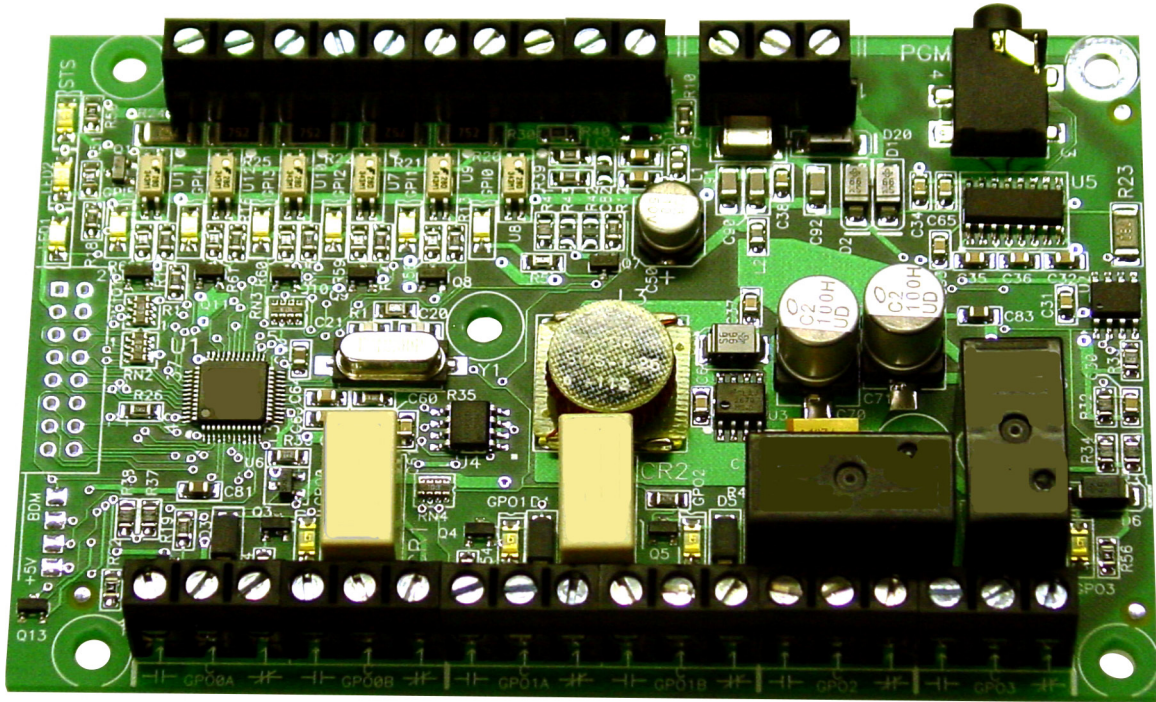

Micro Bear Controller

Covered Models: **ICM-MB-100**



Divelbiss Corporation
9778 Mt. Gilead Road,
Fredericktown, Ohio 43019

Toll Free: 1-800-245-2327
Web: <http://www.divelbiss.com>
Email: sales@divelbiss.com

Manual Contents

Getting Started

| | |
|--|---|
| How to Use this Manual | 3 |
| Configuring the Micro Bear Target in EZ LADDER Toolkit | 4 |
| Loading the Micro Bear Kernel | 4 |
| Getting to Know the Micro Bear | 6 |

Micro Bear Features

| | |
|---|----|
| Programming Port | 9 |
| Status LED | 9 |
| Programmable LEDs..... | 9 |
| Input Power | 10 |
| Mounting | 10 |
| Digital Inputs..... | 11 |
| Counter Input | 12 |
| Digital Outputs..... | 12 |
| Digital Outputs Option Solder Jumpers | 13 |
| Analog Input | 15 |
| Specifications..... | 15 |

WARNING!!

The ICM-MB-100, as with other programmable controllers must not be used alone in applications which could be hazardous to personnel in the event of failure of this device. Precautions must be taken by the user to provide mechanical and/or electrical safeguards external to this device. This device is **NOT APPROVED** for domestic or human medical use.

Getting Started

This section explains how to read this manual and understand the symbols and information that it contains.

To begin using your Micro Bear Controller, you will need to follow these steps:

- Install EZ LADDER Toolkit if not already installed (not included).
- Configure the Micro Bear Controller in the EZ LADDER Toolkit Project Settings.
- Using purchased or self-made cables, connect the Input Power and Programming Port.
- Write a ladder diagram program.
- Download and run the program on the Micro Bear Controller.

Refer to the appropriate sections of this manual for details on the above items.

How to Use this Manual

In this manual, the following conventions are used to distinguish elements of text:

| | |
|-------------------|--|
| BOLD | Denotes labeling, commands, and literal portions of syntax that must appear exactly as shown. |
| <i>italic</i> | Used for variables and placeholders that represent the type of text to be entered by the user. |
| SMALL CAPS | Used to show key sequences or actual buttons, such as OK, where the user clicks the OK button. |

In addition, the following symbols appear periodically in the left margin to call the readers attention to specific details in the text:



Warns the reader of a potential danger or hazard associated with certain actions.



Appears when the text contains a tip that is especially useful.



Indicates the text contains information to which the reader should pay particularly close attention.

All Specifications and Information Subject to Change without Notice

Configuring the Micro Bear Target in EZ LADDER Toolkit

Before you can program and use the MicroBear Controller, it must be configured as a target within the EZ LADDER Toolkit. For help with installing or using EZ LADDER, please refer to the EZ LADDER User's Manual.

1. In EZ LADDER, from the File Menu at the top, click **PROJECT** then **SETTINGS**. This will open the Project Settings Window. Select **Micro Bear PLC** as the target from the choices. Refer to Figure 1.1.

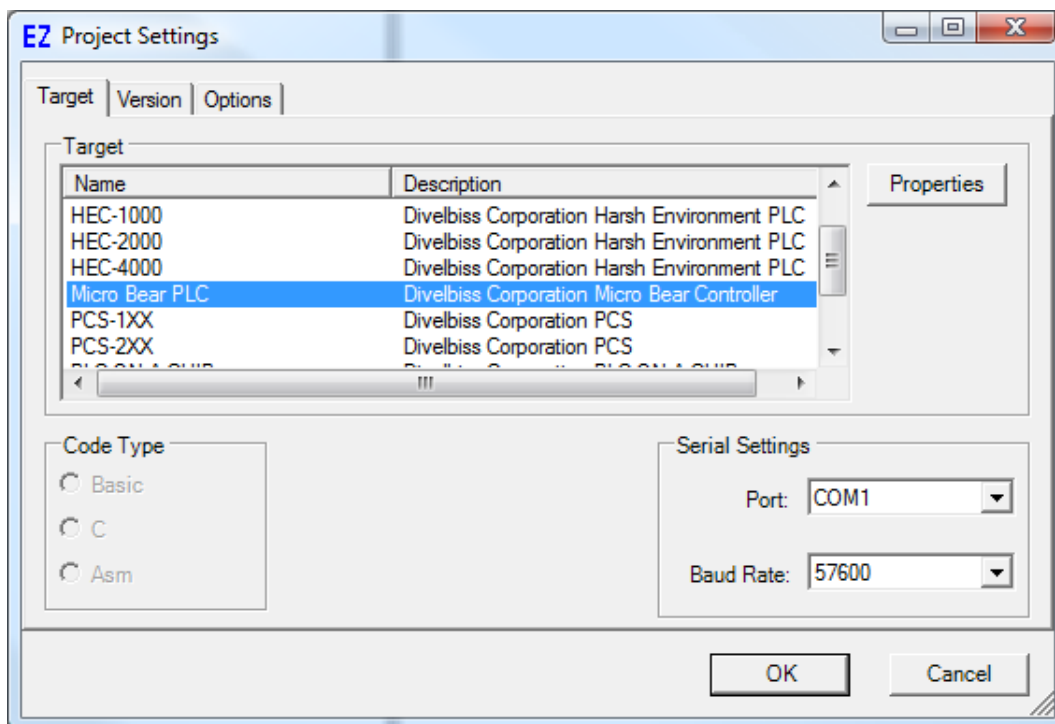

Figure 1.1 - Project Settings Window



2. A new window will open. Select the Model number of the Micro Bear from the drop-down menu. Click **OK** to close this selection window. Click **OK** again, this will close the Project Settings Window, saving the specific Micro Bear model as the target for this ladder diagram project.

Loading the Micro Bear Kernel

THE ICM-MB-XXX WILL NOT FUNCTION UNLESS THIS STEP (KERNEL LOADING) IS COMPLETED.

The kernel is the firmware for the controller and to provide greater flexibility and reliability, Micro Bear Controller shipments are factory shipped **without** a kernel. If this is a new unit from the factory, it will be necessary to load the kernel before a ladder program can be downloaded. If the kernel is already loaded, this step is not required. To upgrade a kernel, see the EZ LADDER User's Manual.

To install the Micro Bear's kernel:

1. Verify the target has been configured (see *Configuring the Micro Bear Target in EZ LADDER Toolkit*).
2. Connect the Programming cable(s) from the computer to the ICM-MB-100. See *Programming Port* in the *Micro Bear Features* section.
3. Create a small one-rung program with a normally open (direct contact) and an output tied together. You may also open a pre-existing program for the Micro Bear.
4. Click the  (Compile) button
5. Click the  (Monitor) button to change from the 'Edit' to 'Monitor' Mode.
6. Click the  (Connect) button to connect to the target. A dialog will appear automatically when no kernel is loaded. If this dialog does not appear, click **PROJECT** then **BOOTLOADER**.
7. Click the **BROWSE** button and select the target's kernel (by partnumber) located by default at C:\Program Files\EZ Ladder\Kernel\

The following are kernel names and descriptions:

| <u>File Name</u> | <u>Description</u> | <u>To be Used on (Partnumber)</u> |
|------------------|-----------------------|-----------------------------------|
| ICM_MB_100.dat | Kernel for ICM-MB-100 | ICM-MB-100 |

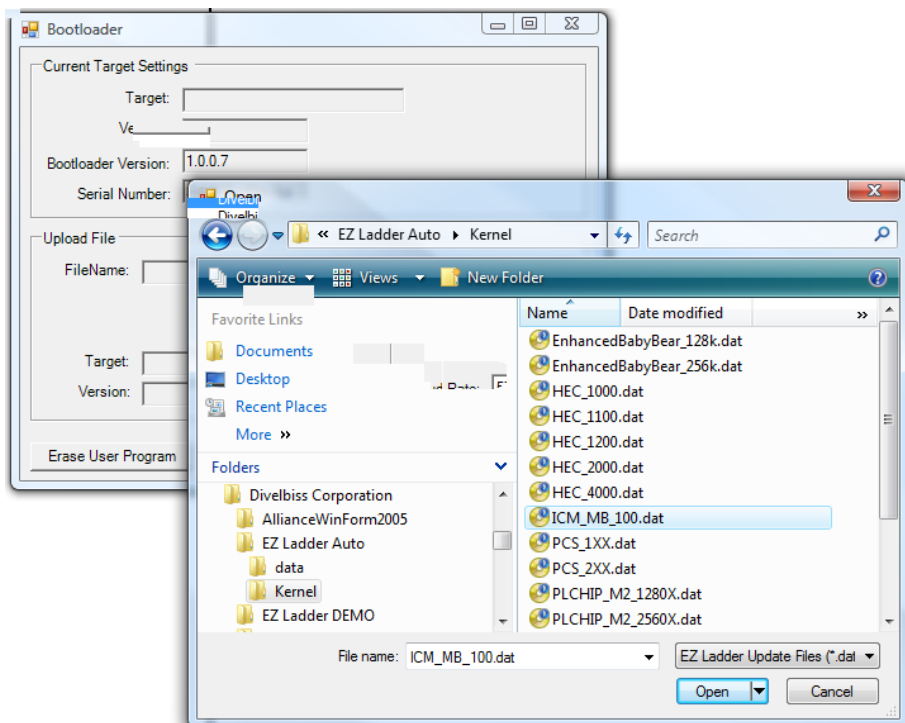
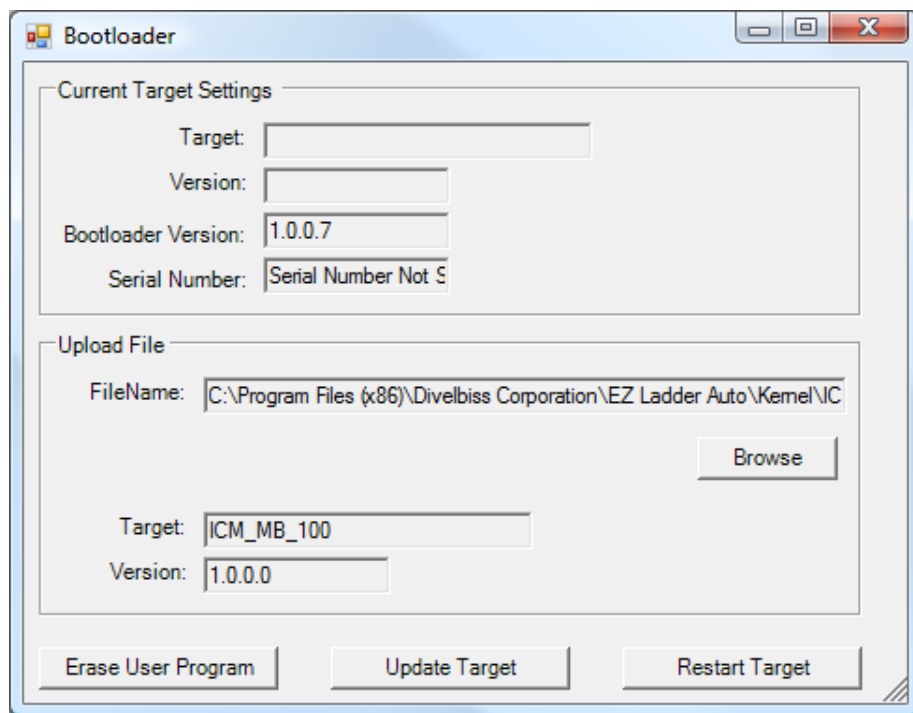

Figure 1.2 - Bootloader / Kernel Select

8. Click the **OPEN** button to finish the kernel selection. Make sure the correct kernel is chosen.
9. Click the **UPDATE TARGET** button to install the kernel.



10. A dialog box will appear to show the status of the kernel installation. This could take a couple of minutes to install.
11. When the dialog windows close, the installation is complete. The Micro Bear is ready to use and may be connected to and programs may be downloaded.



The Micro Bear does not store a serial number internally.

Getting to Know the Micro Bear

The Micro Bear Controller is designed to provide low cost, yet powerful control options. The Micro Bear is designed specifically for OEMs with its open-board design. It can be mounted using the supplied mounting holes or can be mounted using optional snap-track. Refer to Figure 1.4, as it illustrates the Micro Bear.

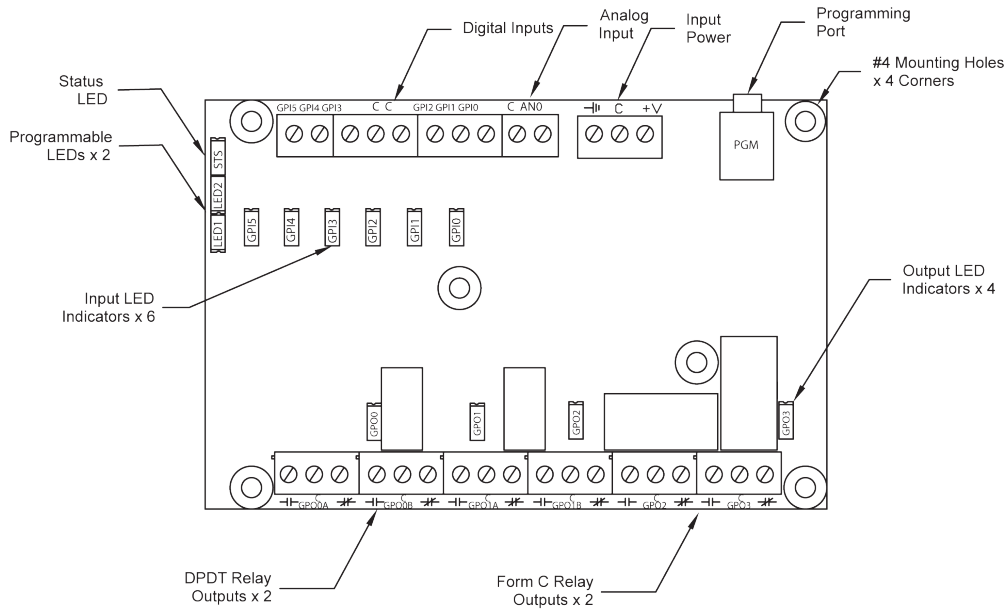

Figure 1.4 - Micro Bear Product Drawing

The Micro Bear features 5mm screw type terminal blocks for all external connections. Each point will accept 20-14 AWG wire size.

Refer to Figure 1.5 for the Micro Bear external Connections..

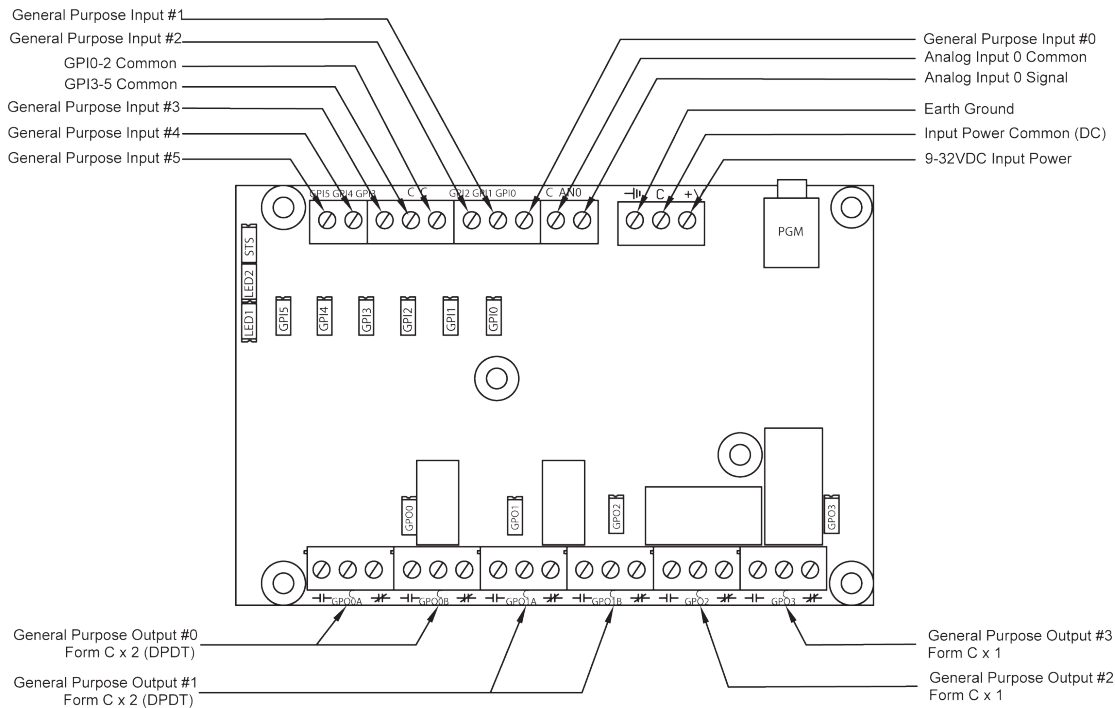

Figure 1.5 - Micro Bear Connections

Micro Bear Features

This section explains the Micro Bear Controller (ICM-MB-100) hardware features, options and information regarding EZ LADDER Toolkit for basic operation. For more in-depth information on EZ LADDER Toolkit including features and how to use, download the latest EZ LADDER Toolkit Manual from www.divelbiss.com.

Programming Port

The Micro Bear is programmed using its Programming Port (COM 0). This RS232 serial port is only to be used for programming using Divelbiss EZ LADDER Toolkit software. This is not a general purpose port and may not be used in any other capacity than programming the controller itself.

The Programming Port defaults to:

| | |
|-------------|-------|
| Baud: | 57600 |
| Parity: | None |
| Data Bits: | 8 |
| Stop Bits : | 1 |

The Micro Bear Programming Port is labeled PGM and accepts a 3.5mm Stereo Audio plug. The programming cable is sold separately. For ordering, use the part number SI-PGM. Refer to Figure 2.1.

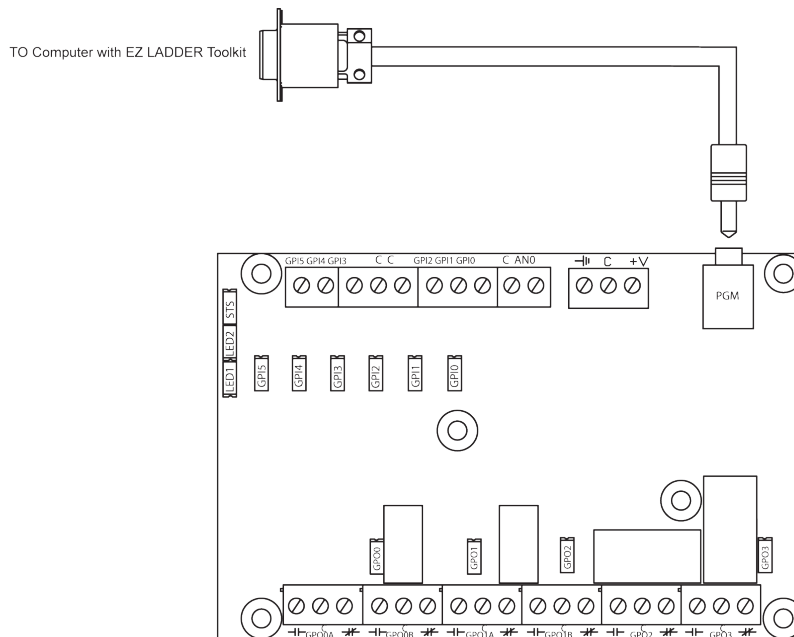

Figure 2.1 - Programming Port Connection

Status LED

The operating status of the Micro Bear can be determined by the Status LED (See Figure 1.4). When the Status LED is flashing at a slow rate, approximately once per second, then there is no ladder program executing. When the Status LED is flashing at a fast rate, approximately 10 times per second, a program has been loaded and it is executing. If the Status LED is flickering quickly, then there is no kernel loaded.

Should the Status LED not flash at all, first check the input power. If the input power is correct and there is still no Status LED, contact Divelbiss Technical Services.

Programmable LEDs

The Micro Bear has two programmable LEDs on-board that may be used in the ladder diagram. These two LEDs are controlled as any other output using the Direct Coil. Their variables are automatically created when the ICM-MB-100 target is selected and are LED1 and LED2 respectively.

Input Power

The Micro Bear may be powered using 9-32VDC. The input power must be of sufficient supply to drive the Micro Bear controller (and I/O loads if driven via on-board jumper options - See the Digital Outputs Section). Figure 2.2 shows the proper power connections to the Micro Bear.

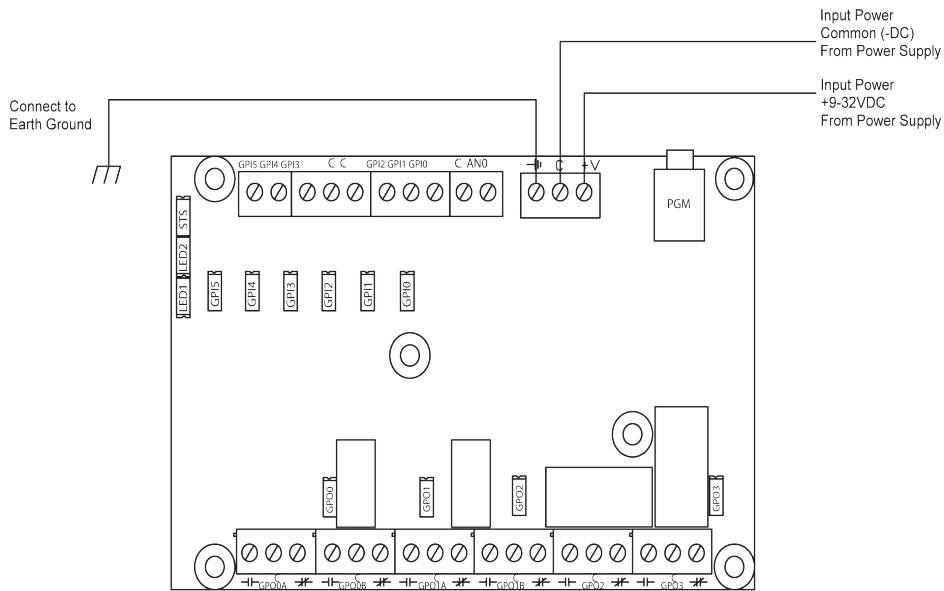

Figure 2.2 - Input Power Connections

Mounting

The Micro Bear mounts is designed to mount to equipment using the four provided mounting holes (1 near each corner). Each hole is of the diameter to accept a #4 screw. See Figure 2.3 for dimensions. The Micro Bear is also designed to mount into snap-track. Consult factory for snap-trak options and pricing.

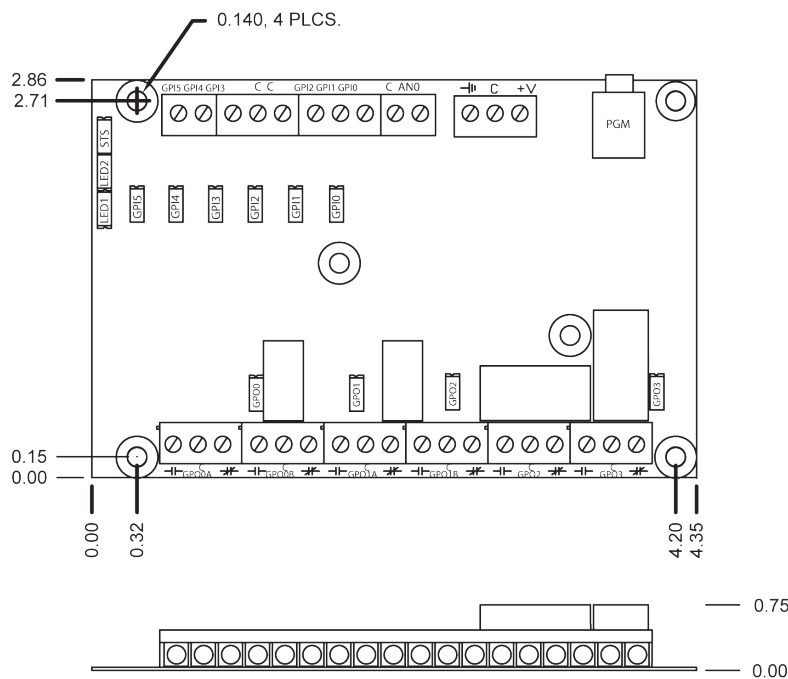

Figure 2.3 - Micro Bear Mounting & Dimensions

Digital Inputs

The Micro Bear includes 6 on-board digital inputs. They are identified in EZ LADDER Toolkit and this manual as GPIO through GPI5. Each digital input can accept an input voltage of 9-32 VDC. The inputs are wired on board with one common terminal for every three inputs (GPIO-GPI2 have a common terminal and GPI3-GPI5 have a common terminal). This configuration allows for the inputs to be used as Sinking or Sourcing in groups of 3 based on your external wiring.

GPIO may be used as general purpose digital input or high speed counter; while GPI1 - GPI5 can only be used as general purpose digital inputs. For information on using GPIO as high speed counter inputs, refer the COUNTER INPUTS Section of this User's Manual.

To read a digital input status in a ladder diagram, place and connect the appropriate contact for your needs. The DIRECT CONTACT and INVERTED CONTACT functions are used to read digital inputs in the ladder diagram. When placing the contact, verify you select the correct input address (GPIO - GPI5) from the provided drop-down menu.

Figure 2.4 illustrates the connections using GPIO-GPI2 as a sinking input and GPI3-GPI5 as a sourcing input.

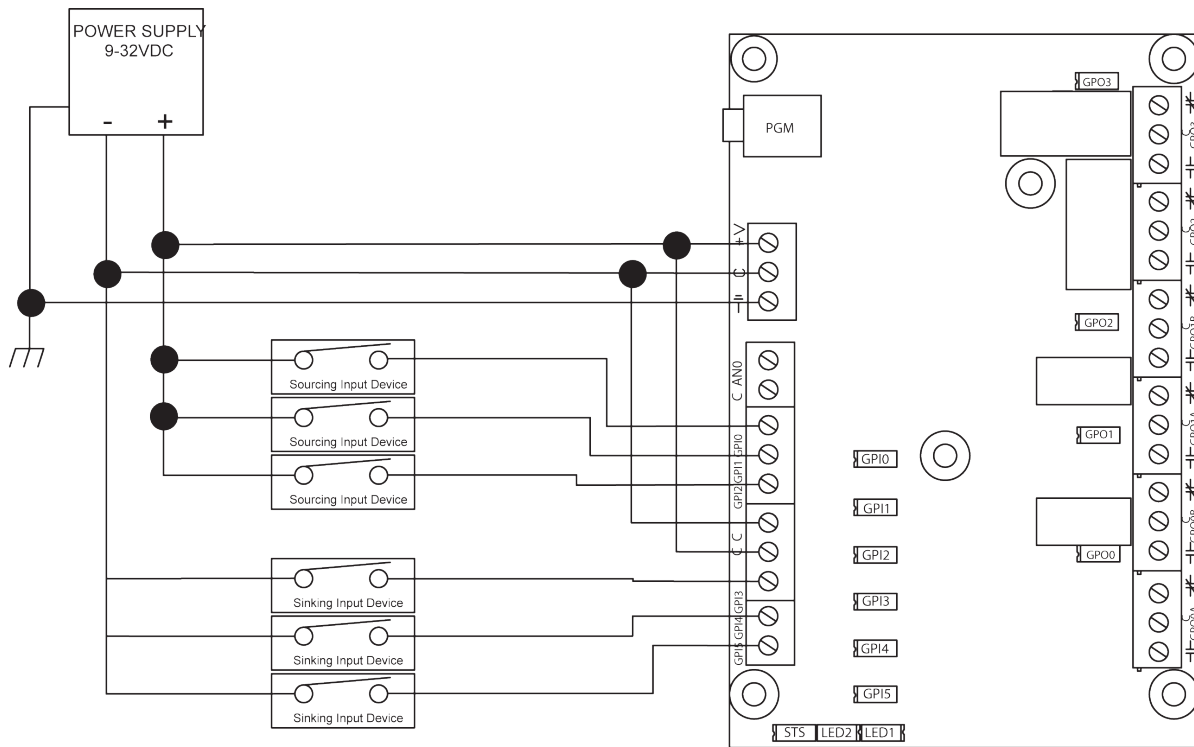

Figure 2.4 - Typical Digital Input Connections

Counter Input

As was noted in the Digital Inputs Section, one of the digital inputs (GPIO) may be utilized as a high speed counter (up counting only). This input will accept a maximum frequency of 25KHz and is optically isolated to promote noise immunity. This input is ideal anywhere that high speed counting is required; such as calculating RPM, batch counting and more.

To use GPIO in a ladder diagram as a high speed counter, you must use the CNTRMR function block. This block, when placed in the ladder diagram, will provide a drop-down menu to select which counter to use. Refer to the EZ LADDER Toolkit User's Manual for details on the CNTRTMR and other function blocks. GPIO is Counter Channel 1 in the CNTRTMR function block.

Please note: Individually, the GPIO input is designed to be used as a digital input only or high speed counter input only. EZ LADDER will allow the placement of contacts and /or CNTRTMR function in any program. Therefore, you can place and use the contacts and the CNTRTMR function block in the same program (they use the same digital input). This can be useful in some programs based on the application, but it is important to know that input contacts will only operate at a fraction of the frequency that the CNTRTMR function block can accurately read.

Typical High Speed Counter connections are shown in Figure 2.5. This example is shown as a sinking input, but this input can still be wired as sinking or sourcing (must match GPI1 and GPI2 as they share the same common (C) terminal).

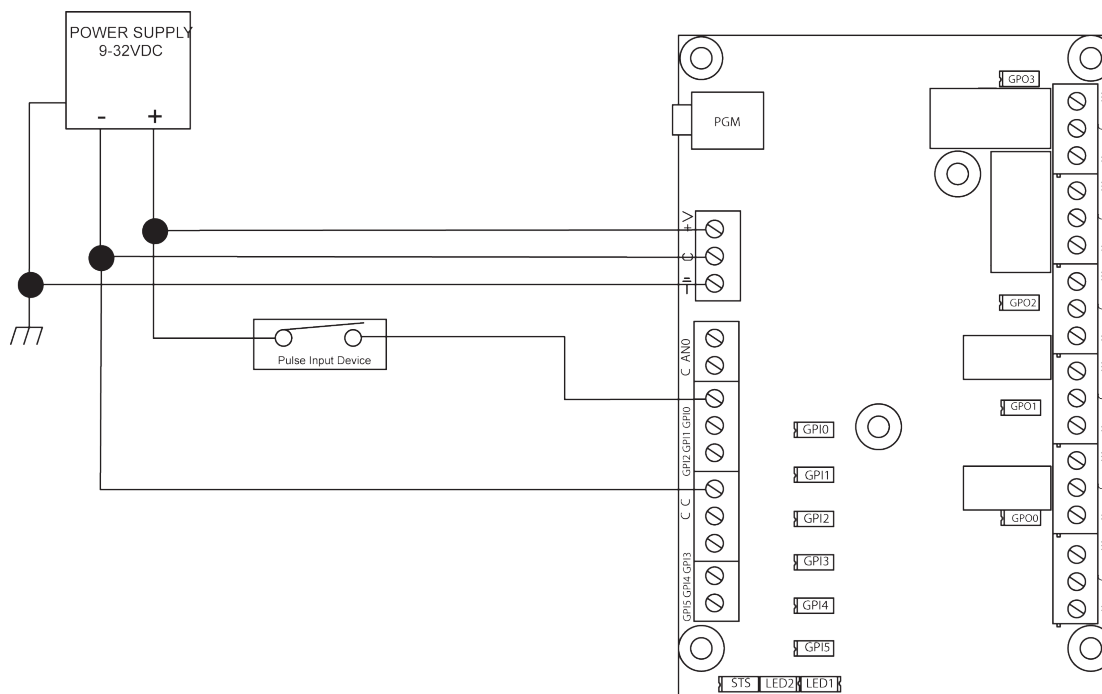

Figure 2.5 - Typical Counter Input Connections

Digital Outputs

The Micro Bear includes 4 on-board digital outputs. They are identified in the EZ LADDER Toolkit and this manual as GPO0 - GPO3. GPO0-GPO3 are relay outputs and consist of two different relay configurations. See the Specifications Section in this manual for complete ratings.

DPDT relays are used for digital outputs GPO0 and GPO1; therefore, each output has two Form C relays (COM/NO/NC x 2) that switch states when the output is energized / de-energized. Default from the factory, these are *Dry Contacts*. Figure 2.6 represents the standard configuration of GPO0 and GPO1. The terminal blocks for GPO0 and GPO1 are labeled with a *A* and *B* representing each of the Form C poles.

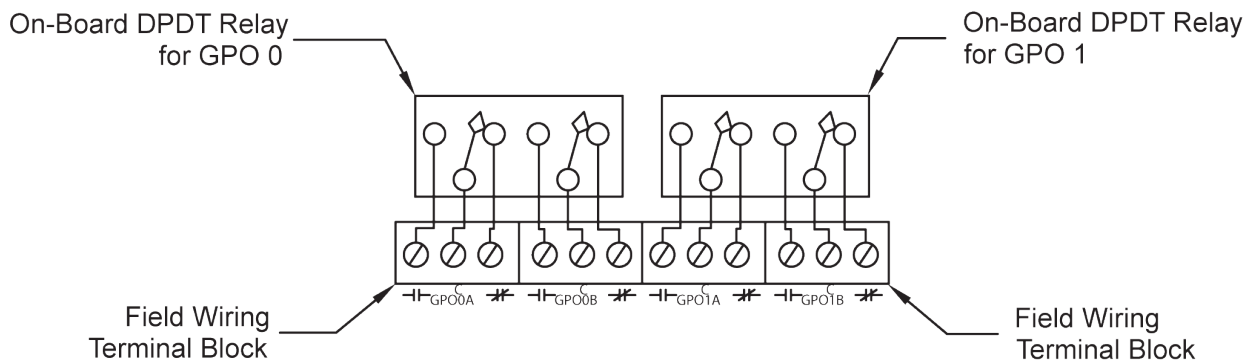

Figure 2.6 - GPO0 / GPO1 Relay Diagram

Form C relays are used for digital outputs GPO2 and GPO3; therefore, each output has a normally open and normally closed contact that switch states when the output is energized / de-energized. Default from the factory, these are *Dry Contacts*. Figure 2.7 represents the standard configuration of GPO2 and GPO3.

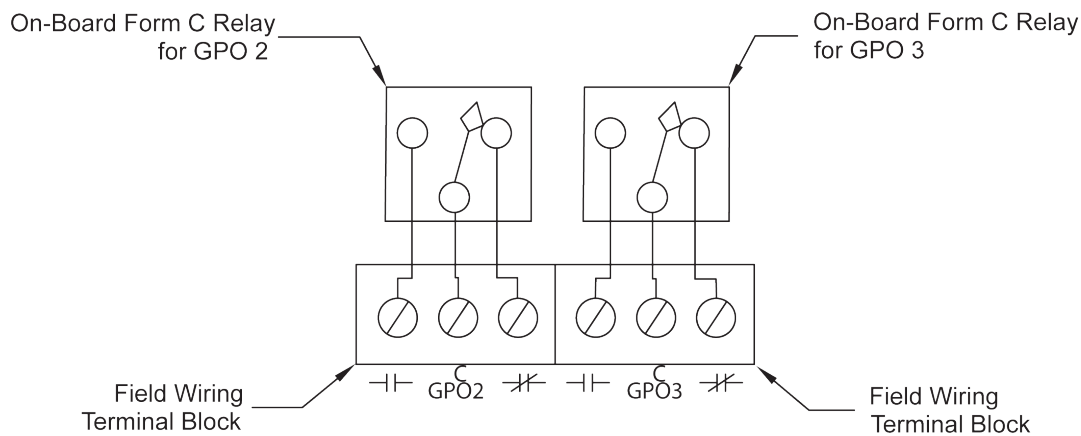

Figure 2.7 - GPO2 / GPO3 Relay Diagram



To control a digital output in a ladder diagram, place and connect the appropriate coil for your needs. The **DIRECT COIL** and **INVERT-ED COIL** functions are used to control digital outputs in the ladder diagram. When placing the coil, verify you select the correct output address (GPO0 - GPO3) from the provided drop-down menu.

Digital Outputs Option Solder Jumpers

As previously noted, the Micro Bear comes from the factory with *Dry Contacts* on all relay outputs. These contacts can be jumpered so that their commons (C) can be connected electrically. Each output relay contact set can be individually connected to this on-board bus. On the solder-side of the Micro Bear (back side), a set of jumper solder type pads is provided for each set of relay contacts (JMP1-6). Soldering a jumper between these two jumper pads will connect the output relay common (C) to the bus. Refer to Figure 2.8 for the jumper location and Figure 2.9 for the electrical representation.

In addition to being able to connect the relay commons to a bus, this bus can be electrically connected to either the +VDC Input Power or the Input Power Common. To connect the bus to the +VDC Input Power, solder a jumper between the JMP7 pads. To connect the bus to the Input Power Common, solder a jumper between the JMP8 pads. Refer to Figure 2.8 for the jumper location and Figure 2.9 for the electrical representation.

 When using the relay outputs with the optional on-board jumper bus, the total output current is limited. Refer to the Specifications Section for relay data and current limitations. **Using loads too large for this bus system will result in damage to the Micro Bear.**

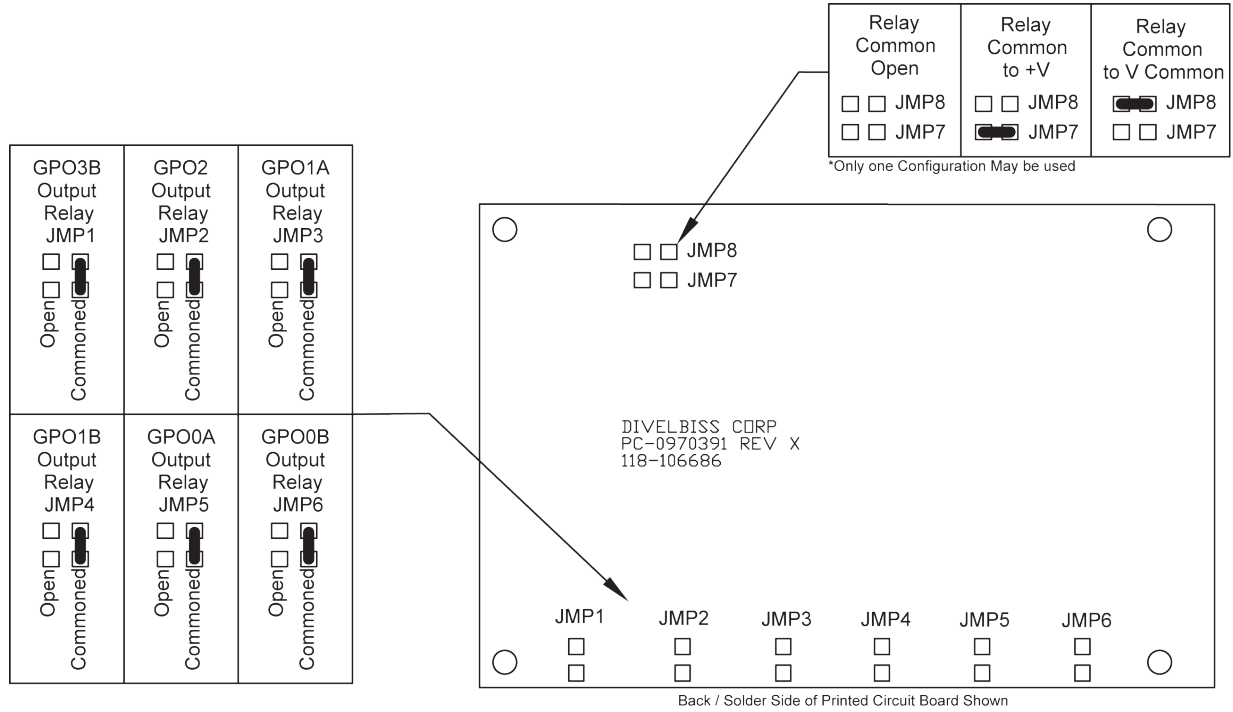

Figure 2.8 - Optional Solder Jumper Identification

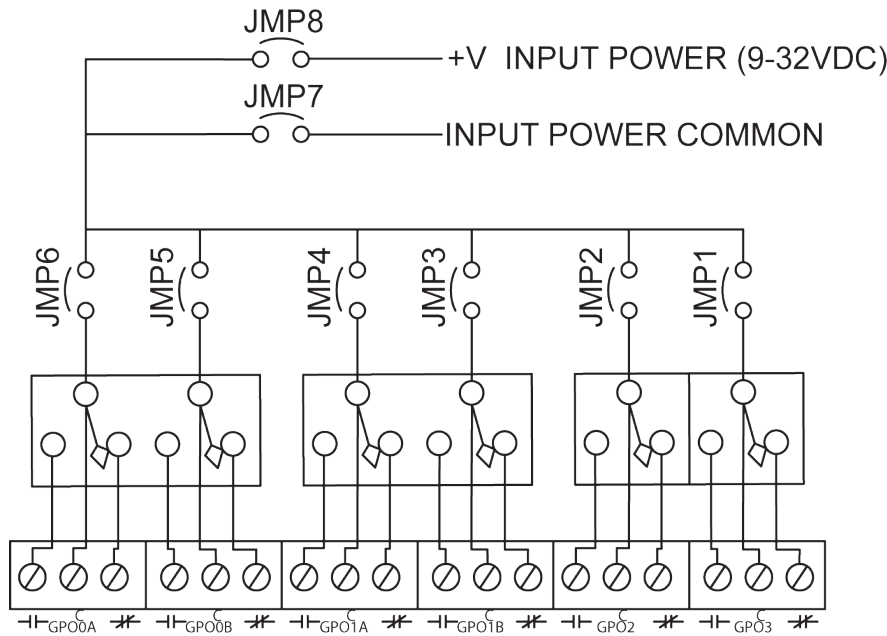

Figure 2.9 - Optional Solder Jumper Schematic

Analog Input

The Micro Bear provides 1 analog input for external devices. The analog input is single-ended with 10 bits of accuracy and can accept an input signal from 0-5VDC. This single-ended analog input requires the analog signal to be input on the AN0 terminal. The analog input common (C) terminal is connected on-board to the input power common terminal (C).



A variable (AN0) is automatically created when the Micro Bear target is selected. This variable (AN0) will represent the actual current reading on the analog input as an integer number (0-1023). To use the analog input reading, place the appropriate analog input variable as an input to function blocks.

Figure 2.10 shows the typical analog input wiring connections.

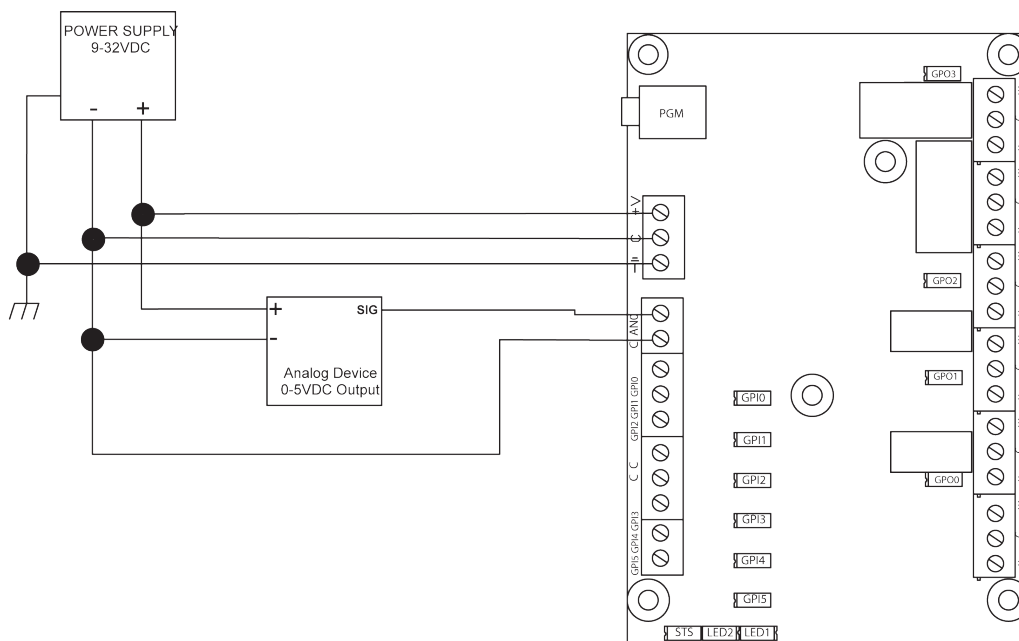

Figure 2.10 - Typical Analog Input Connections

Specifications

| | |
|-------------------|--|
| Processor: | PLC on a Chip™ |
| Memory: | 64K Flash, 512 Bytes RAM, 406 Bytes EEPROM, 100 Bytes Retentive |
| Serial Ports: | 1 Programming Port |
| Digital Inputs: | Qty 6, Rated 9-32VDC |
| Digital Outputs: | Total 4 Relay Outputs Qty 2, DPDT, Dry Contacts rated 2A@30VDC, .5A@125VAC, .25A@250VAC Qty 2 SPDT, Dry Contacts rated 5A@125VAC, 5A@250VAC, 5A@30VDC Relay Output Common Terminals can be jumpered on-board to Input Power +VDC or Common Maximum current when jumpered on-board is 7 Amps total (DC) |
| Counters: | 1 Channels, Count Up, 25KHz Max. (using GPIO) |
| Analog Inputs: | 1 Channels, 0-5VDC, 10 bit, Single Ended |
| Input Power: | 9-32VDC, 105mA DC Maximum Current @ 24VDC (No Output Loads Included) |
| Operating Temp: | 0-60° C |
| Program Language: | Ladder Logic using Divelbiss EZ LADDER Toolkit. |
| Dimensions: | 2.86" Wide x 4.35" Length x .75" Tall. |
| Mounting: | Panel Mount using screws or optional Snap-Track (sold separately) |
| Type: | Open Board |