

AE ADAM

Adam Equipment

CBW SERIES

(P.N. 4276, Rev. B7, March 2006)

Software rev.: 1.2- 2.04
(For CBW 6H / 12aH, rev.:1.4-3.00)

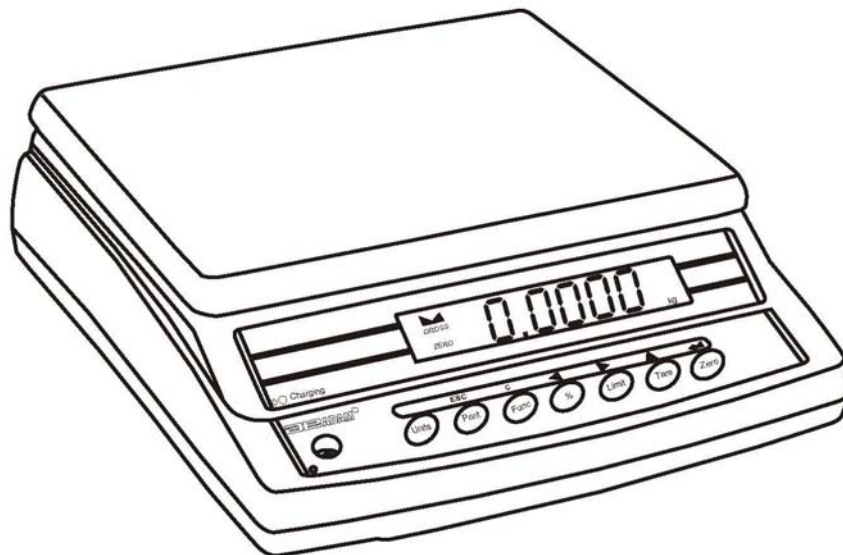

NOVA-TECH
INTERNATIONAL
800 Rockmead Dr Ste 102 • Houston, TX 77339-2112
Tel: (281) 359-8538 • Toll Free Tel: (866) 433-6682
Fax: (281) 359-0084 • Toll Free Fax: (866) 433-6684
sales@novatech-usa.com • www.novatech-usa.com

CONTENTS

1.0	INTRODUCTION.....	2
2.0	SPECIFICATIONS	3
3.0	INSTALLATION.....	5
3.1	LOCATING THE SCALE	5
3.2	INSTALLATION OF CBW SERIES.....	5
4.0	KEY DESCRIPTIONS	6
5.0	DISPLAYS	8
6.0	OPERATION.....	8
6.1	ZEROING THE DISPLAY	8
6.2	TARING.....	9
6.3	WEIGHING A SAMPLE	9
6.4	PERCENT WEIGHING.....	9
6.5	PARTS COUNTING	10
6.6	CHECK-WEIGHING	10
6.6.1	Setting up Check-weighing while weighing.....	11
6.6.2	Setting up Checkweighing while Parts Counting	12
6.7	ACCUMULATED TOTAL.....	12
6.8	MANUAL ACCUMULATION.....	13
6.9	AUTOMATIC ACCUMULATION.....	14
7.0	PARAMETERS	14
7.1	INCREMENT VALUE	15
7.2	CONTROL THE BACKLIGHT.....	15
7.3	AUTOMATIC ACCUMULATION.....	15
7.4	ACCUMULATION OF DATA IN MEMORY WHEN [PRINT] IS PRESSED.....	16
7.5	AUTO ZERO RANGE.....	16
7.6	SELECTABLE UNIT OF WEIGHT DISPLAYED.....	16
7.7	SETTING OF THE CHECK WEIGHING ALARM.....	17
7.8	SPEED AT WHICH THE MACHINE WILL RUN THE ADC	17
8.0	BATTERY OPERATION	18
9.0	RS-232 INTERFACE.....	19
9.1	INPUT COMMANDS FORMAT	20
10.0	CALIBRATION	21
11.0	ERROR CODES	22
12.0	REPLACEMENT PARTS AND ACCESSORIES	23
13.0	SERVICE INFORMATION	23

1.0 INTRODUCTION

- The **CBW** series of scales provide an accurate, fast and versatile series of general purpose weighing scales with counting, % weighing and check-weighing functions.
- There are 2 series of scales - **CBW** scales which use kilograms as the default unit and the **CBWa** range of scales have changeable units from pounds to kilograms. The scales in these series share the same functions except the **CBWa** series have the ability to change the weighing units.
- There are 6 models in each series with capacities up to 45 kg / 100 lb.
- These all have stainless steel weighing platforms on an ABS base assembly.
- All scales have sealed keypads with colour coded membrane switches and the displays are large easy to read liquid crystal type displays (LCD). The LCD's are supplied with a backlight.
- The scales include automatic zero tracking, audible alarm for pre-set weights, automatic tare, an accumulation facility that allows the count to be stored and recalled as an accumulated total and bi-directional RS-232 interface for communicating with a PC or printer.

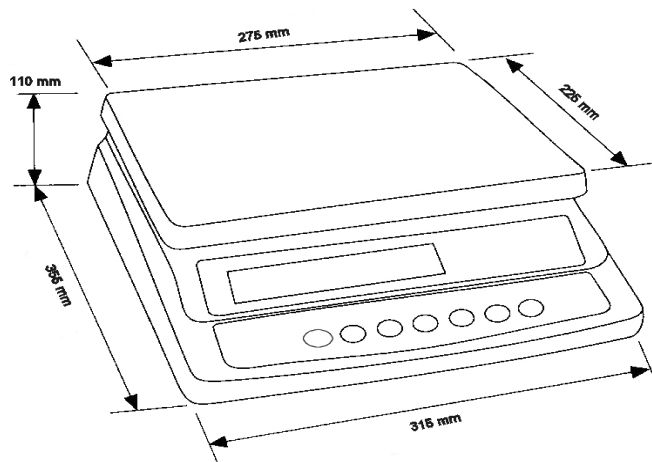

2.0 SPECIFICATIONS

CBW SERIES

Model #	CBW 3	CBW 6H	CBW 6	CBW 15	CBW 30	CBW 45
Maximum Capacity	3 kg	6 kg	6 kg	15 kg	30 kg	45 kg
Readability	0.1 g	0.1 g	0.2 g	0.5 g	1 g	2 g
Tare Range	-3 kg	-6 kg	-6 kg	-10 kg	-30 kg	-45 kg
Repeatability (Std. Dev.)	0.1 g	0.1 g	0.2 g	0.5 g	1 g	2 g
Linearity ±	0.2 g	0.2 g	0.4 g	1 g	2 g	4 g
Units of measure	Kg, g					

CBWa SERIES

Model: CBW-6a

UNITS OF MEASURE	MAXIMUM CAPACITY	TARE RANGE	READABILITY	REPEATABILITY	LINEARITY
Grams	3000.0 g	-3000.0 g	0.1 g	0.1 g	0.2 g
Kilograms	3.0000 kg	-3 kg	0.0001 kg	0.0001 kg	0.0002 kg
Pounds	6.0000 lb	-6 lb	0.0002 lb	0.0002 lb	0.0004 lb
Pounds/Ounces	6 lb 0.0 oz	-6 lb 0.0 oz	0.1 oz	0.1 oz	0.1 oz

Model: CBW-12aH

UNITS OF MEASURE	MAXIMUM CAPACITY	TARE RANGE	READABILITY	REPEATABILITY	LINEARITY
Grams	6000.0 g	-6000.0 g	0.1 g	0.1 g	0.2 g
Kilograms	6.0000 kg	-6 kg	0.0001 kg	0.0001 kg	0.0002 kg
Pounds	12 lb	-9.9998 lb	0.0002 lb	0.0002 lb	0.0004 lb
Pounds/Ounces	12 lb	-9 lb 15.9oz	0 to 10 lb:0.01oz 10 to 12 lb:0.1oz	0.01 oz	0.02 oz

Model: CBW-12a

UNITS OF MEASURE	MAXIMUM CAPACITY	TARE RANGE	READABILITY	REPEATABILITY	LINEARITY
Grams	6000.0 g	-6000.0 g	0.2 g	0.2 g	0.4 g
Kilograms	6.0000 kg	-6 kg	0.0002 kg	0.0002 kg	0.0004 kg
Pounds	12 lb	-9.9995 lb	0.0005 lb	0.0005 lb	0.001 lb
Pounds/Ounces	12 oz	-9 lb 15.9 oz	0.1 oz	0.1 oz	0.1 oz

Model: CBW-35a

UNITS OF MEASURE	MAXIMUM CAPACITY	TARE RANGE	READABILITY	REPEATABILITY	LINEARITY
Grams	15000.0 g	-10000.0 g	0.5 g	0.5 g	1 g
Kilograms	15.0000 kg	-10 kg	0.0005 kg	0.0005 kg	0.001 kg
Pounds	35.000 lb	-35 lb	0.001 lb	0.001 lb	0.002 lb
Pounds/Ounces	35 lb 0.0 oz	-35 lb 0.0 oz	0.1 oz	0.1 oz	0.1 oz

Model: CBW-65a

UNITS OF MEASURE	MAXIMUM CAPACITY	TARE RANGE	READABILITY	REPEATABILITY	LINEARITY
Grams	30000 g	-30000 g	1 g	1 g	2 g
Kilograms	30.000 kg	-30 kg	0.001 kg	0.001 kg	0.002 kg
Pounds	65.000 lb	-65 lb	0.002 lb	0.002 lb	0.004 lb
Pounds/Ounces	65 lb 0.0oz	-65 lb 0.0 oz	0.1 oz	0.1 oz	0.1 oz

Model: CBW-100a

UNITS OF MEASURE	MAXIMUM CAPACITY	TARE RANGE	READABILITY	REPEATABILITY	LINEARITY
Grams	45000 g	-45000 g	2 g	2 g	4 g
Kilograms	45.000 kg	-45 kg	0.002 kg	0.002 kg	0.004 kg
Pounds	100 lb	-99 lb	0.005 lb	0.005 lb	0.01 lb
Pounds/Ounces	99lb15.0 oz	-99 lb 15.0 oz	0.1 oz	0.1 oz	0.2 oz

Common Specifications for CBW and CBWa

Interface	RS-232 bi-directional Interface (Optional)
Stabilisation Time	2 Seconds typical
Operating Temperature	0°C - 40°C 32°F - 104°F
Power supply	9 VDC, 800 mA Through an external adapter
Battery	Internal rechargeable battery (~70 hours operation)
Calibration	Automatic External
Display	6 digits LCD digital display
Scale Housing	ABS Plastic, Stainless Steel platform
Pan Size	225 x 275 mm / 8.9" x 10.8"
Overall Dimensions (wxdxh)	315 x 355 x 110 mm 12.4" x 14" x 4.3"
Net Weight	4.1 kg / 9 lb
Applications	Weighing Scales
Functions	Weighing, parts counting, % weighing, Checkweighing

3.0 INSTALLATION

3.1 LOCATING THE SCALE

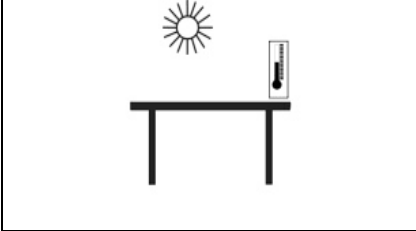
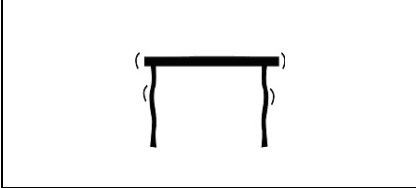
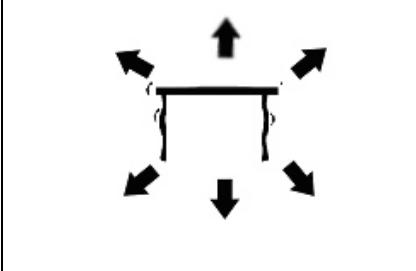
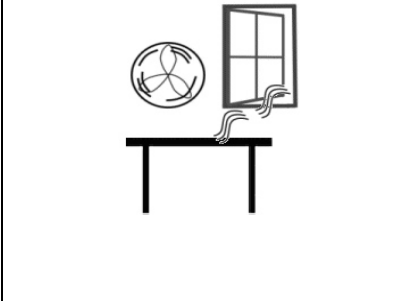

	<ul style="list-style-type: none">• The scales should not be placed in a location that will reduce the accuracy.• Avoid extremes of temperature. Do not place in direct sunlight or near air conditioning vents.
	<ul style="list-style-type: none">• Avoid unsuitable tables. The table or floor must be rigid and not vibrate.
	<ul style="list-style-type: none">• Avoid unstable power sources. Do not use near large users of electricity such as welding equipment or large motors.• Do not place near vibrating machinery.
	<ul style="list-style-type: none">• Avoid high humidity that might cause condensation. Avoid direct contact with water. Do not spray or immerse the scales in water.• Avoid air movement such as from fans or opening doors. Do not place near open windows or air-conditioning vents.• Keep the scales clean. Do not stack material on the scales when they are not in use.



3.2 INSTALLATION OF CBW SERIES

- The CBW Series comes with a stainless steel platform packed separately.
- Place the platform in the locating holes on the top cover.
- Do not press with excessive force as this could damage the load cell inside.

- Level the scale by adjusting the four feet. The scale should be adjusted such that the bubble in the spirit level is in the centre of the level and the scale is supported by all four feet.
- Attach the power supply cable to the connector on the bottom of the scale. Plug in the power supply module. The power switch is located on the base on the right side of the scale.
- The scale will first display the model number (CBW 30- where 30 denotes the capacity of the scale in kg), followed by the revision numbers (1.2-2.03 where 1.2 is the current hardware revision number of the main circuit board and 2.03 is the current software revision number). A self-test is followed next. At the end of the self-test it will display “**ZERO**”, if the zero condition has been achieved. A stable symbol and “**GROSS**” indicators are also displayed.

4.0 KEY DESCRIPTIONS

KEYS	PRIMARY FUNCTION	SECONDARY FUNCTION
[Zero]	Sets the zero point for all subsequent weighing. The display shows zero.	 or [Enter] key when setting parameters or other functions.
[Tare]	It tares the scale and stores the current weight in memory as a tare value, subtracts the tare value from the weight and shows the results. This is the net weight.	A secondary function  is available to increment the active digit when setting a value for parameters or other functions.

[Limit]	It sets the limits for check weighing and allows setting of either the low limit or the high limit or both.	A secondary function  is available to move the active digit to the right when setting values for parameters or other functions.
[%]	It enters the percent weighing function. Allows the weight, unit weight, and count to be seen when parts counting.	A secondary function  is available to move the active digit to the left when setting values for parameters or other functions.
[Func]	This is used to select the function of the scale. When the scale is weighing, it will select parts counting. When it is not in the weighing mode it will return the user to weighing.	A secondary function [C] is available to act as a clear key when setting values for parameters or other functions.
[Print]	It is used to print the results to a PC or printer using the optional RS-232 interface. It also adds the value to the accumulation memory if the accumulation function is not automatic.	A secondary function [ESC] is used to return to normal operation when the scale is in a parameter setting mode.
[Units]	It is used to change the weighing units of the display from kilograms to grams and back to kilograms for CBW series. For CBWa scales this key will select kilograms, grams, Pounds and Pounds/ounces for the weighing unit, if enabled. This should only be done in gross weighing or at zero.	None.

5.0 DISPLAYS

The LCD display will show a value and a unit to the right of the digits.

Other labels are TARE, GROSS, ZERO,  / O (Stable) and  (Low battery).

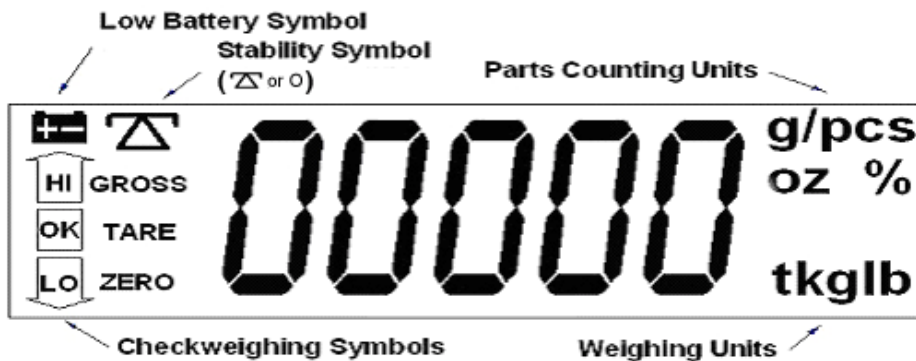

6.0 OPERATION

6.1 ZEROING THE DISPLAY

- You can press the **[Zero/Enter]** key at any time to set the zero point from which all other weighing and counting is measured. This will usually be necessary when the platform is empty. When the zero point is obtained the display will show the indicator for **"ZERO"**.
- The scale has an automatic re-zeroing function to account for minor drifting or accumulation of material on the platform. However you may need to press the **[Zero/Enter]** key to re-zero the scale if small amounts of weight are still shown when the platform is empty.

6.2 TARING

- Zero the scale by pressing [**Zero/Enter**]. The zero indicator will be on. Place a container on the pan and its weight will be displayed.
- Press [**Tare**] to tare the scale. The weight that was displayed is stored as the tare value and it is subtracted from the display, leaving zero on the display. The "**TARE**" indicator will be on and the "**GROSS**" indicator will be off. As product is added only the weight of the product will be shown. The scale could be tared a second time if another type of product was to be added to the first one. Again only the weight that is added after taring will be displayed.
- When the container is removed a negative value will be shown. If the scale was tared just before removing the container, this value is the gross weight of the container plus all products which were removed. The "**ZERO**"- indicator will also be on because the platform is back to the same condition it was when [**Zero/Enter**] was last pressed.

6.3 WEIGHING A SAMPLE

To determine the weight of a sample, first tare an empty container if used, then place the sample in the container. The display will show the weight and the units of weight currently in use.

6.4 PERCENT WEIGHING

- The scale will allow a sample weight to be shown as 100%. Then any other weight placed on the scale will be displayed as a percentage of the original sample. For example if 350g is placed on the scale and the [%] key is pressed the display will show 100.00%. Remove the 350g weight and place a 300g weight on the scale. The display will show 85.71% as 300g is 85.71% of 350g.

NOTE: The scale may jump by large numbers unexpectedly if small weights are used to set the 100% level. For example, if only 23.5g is placed on a scale with 0.5g increments and the scale is set to 100%, the display will show 100.00%, however a small change of weight will cause the display to jump to 102.13% as one scale division (0.5g) increase to 24.0g will be equivalent to an increase of 2.13%.

- Pressing [**Func**] will return the scale to weighing.

6.5 PARTS COUNTING

- Before beginning, tare the weight of any container that will be used, leaving the empty container on the scale.
- **For CBW- 6H /12aH, place the sample first and then press the [Func] key.** For all other models first press the [Func] key to begin. The scale will show "**P 10**" asking for a sample size of 10 parts. Change the sample size by pressing the [Tare/↑] key. The display will cycle through the options: 10, 20, 50, 100, 200 and back to 10.
- Place the number of samples on the scale. The number should match the options for parts counting, i.e., 10, 20, 50, 100 or 200 pieces.
- Press the [Zero/Enter] key when the number matches the number of parts used for the sample. As more weight is added, the display will show the number of parts (pcs).
- Press the [%] key to display unit weight (g/pcs or lb/pcs), Total weight (kg or lb) or the count (pcs).
- Press [Func] to return to normal weighing.
- 'lb' will be shown on the **CBWa** scales when weighing unit is set to pounds.

6.6 CHECK-WEIGHING

Check-weighing is a procedure to cause an alarm to sound when the weight on the scale meets or exceeds the values stored in memory. The memory holds values for a high limit and a low limit. Either or both the limits can be used.

NOTE: The alarm can be set to OFF (See the section 7.7 on Parameter). In this case the display will indicate whenever the weight is within or exceeds the limits by showing 'OK', 'HI' or 'LO'.

6.6.1 Setting up Check-weighing while weighing

- Press [**Limit**]. It will show the current High Limit with the left most digit flashing and the HI symbol on the left of the display.
- To select the digit to be changed press [**Limit/→**] or [**%/←**]. Use [**Tare/↑**] to increment the flashing digit. When the desired value is shown press [**Zero/Enter**] to accept the value. If you want to reset the value to zero, press the [**Func/C**] key to clear the value.
- After pressing [**Zero/Enter**] the display will then show the Low Limit, the “**LO**” symbol will be on to the left side of the display. Enter the low limit in the same way the high limit was entered.
- The limits are displayed in **Kg**.
- Pressing the [**Zero/Enter**] key will return the scale to weighing, with the Check-weighing function enabled.
- When a weight is placed on the scale the arrows will show whether the weight is above or below the limits and the beeper will sound as described below.

BOTH LIMITS SET	The display will show OK and the beeper will sound when the weight is between the limits.
LOW LIMIT SET	HIGH LIMIT is set to zero. The display will show OK and the beeper will sound when the weight is less than the Low Limit. Above the Low Limit the display will show HI and the beeper will be off.
HIGH LIMIT SET	LOW LIMIT is set to zero. The display will show LO and the beeper will be off when the weight is less than the High Limit. Above the High Limit the display will show OK and the beeper will be on.
BOTH LIMITS SET LOW IS SET GREATER THAN HIGH	The beeper will never sound and the display will show LO if the weight is less than the Low Limit and HI if the weight is greater than the Low Limit.

6.6.2 Setting up Checkweighing while Parts Counting

- Checkweighing facility can be set up for Parts Counting by entering values as Low and High Limits to be keyed in by the user. The limits are displayed in **PCS**.
- Press **[Func]** to enter the Parts Counting mode. Press **[Zero/Enter]** to fix a sample size. Press **[Limit]** and enter the numeric values for high and low limits following the same procedure as stated in the earlier section.

NOTE:

- The weight must be greater than 20 scale divisions for the checkweighing to operate.
- To disable the Checkweighing function, enter zero into both limits by pressing **[Limit/→]** to recall the current settings.
- When the current limits are shown, press **[Func/C]** to clear the settings and then press **[Zero/Enter]** to store the zero values.

6.7 ACCUMULATED TOTAL

- The scale can be set to accumulate when a weight is added to the scale automatically or manually by pressing **[Print]**.
- See Section 7.3 on PARAMETERS for details. The accumulation function is only available when weighing. It is disabled during percent weighing or parts counting.
- The accumulated weights will be stored in the master unit of the scale, i.e. kg or lbs.
- If at any time the weighing units are changed, the accumulated data will be lost.

6.8 MANUAL ACCUMULATION

- When the scale is set to manual accumulation the weight displayed will be stored in memory when the **[Print]** key is pressed and the weight is stable.
- The display will show "**ACC 1**" and then the total in memory for 2 seconds before returning to normal. If the optional RS-232 interface is installed the weight will be output to a printer or PC.
- Remove the weight, allowing the scale to return to zero and put a second weight on. Press **[Print]**, the display will show "**ACC 2**" and then show the new total.
- Continue until all weights have been added.
- To view the total in memory press the **[Print]** key when the scale is at zero. The display will show the total number of items "**ACC xx**" and the total weight before returning to zero. The total will also be printed via the RS-232 interface.
- To erase the memory, press **[Print]** to view the totals and then press the **[Func/C]** key to clear the memory.

6.9 AUTOMATIC ACCUMULATION

- When the scale has been set to Automatic Accumulation the value is stored in memory automatically.
- Add a weight to the scale. The beeper will sound when the scale is stable indicating the value is accepted. Remove the weight.
- The display will show "**ACC 1**" and then the total in the memory before it returns to zero. Adding a 2nd weight will repeat the process.
- While the weight is on the scale, press the **[Print]** key to show the values immediately- first the accumulation number "**ACC x**" and then the total will be shown. In this case the scale will not show the value when the weight is removed.
- In all cases the scale must return to zero or a negative number before another sample can be added to the memory.
- More products can be added and **[Print]** be pressed again. This can continue for up to 99 entries till the capacity of display is exceeded.

7.0 PARAMETERS

The parameters can be chosen by the user to set the scale to:

- Display the weight in other increments of weight to minimise the affects of vibration, wind or other environmental conditions.
- Control the back light on the display. It may be necessary to turn the backlight off to maximise battery life.
- Set the Accumulation to Automatic, manual or set the RS-232 interface to continuously print the weight.
- To enable the accumulation when **[Print]** is pressed or to disable it.
- Set a range for auto zero.
- Select another weighing unit than the standard.
- Set the check weighing alarm.
- Set the speed.

To set parameters, press the **[Func]** and **[Print]** keys at the same time.

7.1 INCREMENT VALUE

- The first parameter on setting the increment value will be displayed as "**Inc xx**" where **xx** can be 1, 2, 5 or 10. The first value shown is the default scale increment value.
- To change to a different increment value press **[Tare/↑]**.
- Press the **[Zero/Enter]** key to store the changed value and move to the next parameter.

7.2 CONTROL THE BACKLIGHT

- The standard is to have the backlight operate automatically i.e., turning it off when the scale is not being used.
- The backlight can be set to be "**EL on**" (always on), "**EL AU**" (Automatic) or "**EL off**" (always off). The maximum battery life is achieved with the backlight turned off.
- Press the **[Tare/↑]** key to change the setting.
- Press the **[Zero/Enter]** to store the changed setting and move to the next parameter.

7.3 AUTOMATIC ACCUMULATION

- With "**Au on**" the memory will accumulate the weight automatically.
- "**Au off**" will enable the manual accumulation.
- "**P Cont**" will set the RS-232 interface to send the weight continuously and the accumulation function is disabled.
- Press the **[Tare/↑]** key to change the setting.
- Press the **[Zero/Enter]** key to store the changed setting and move to the next parameter.

7.4 ACCUMULATION OF DATA IN MEMORY WHEN [PRINT] IS PRESSED

- To accumulate weight in the memory when **[Print]** is pressed, set the scale to "**ACC on**".
- To use the **[Print]** key to only print the weight without adding it to memory, set to "**ACC off**".
- Press **[Tare/↑]** to change the setting between **on** and **off**.
- Press the **[Zero/Enter]** key to store the changed setting and move to the next parameter.

7.5 AUTO ZERO RANGE

- The auto-zero will automatically set the scale to zero when the displayed weight is almost near zero. This helps to make sure that the scale is measuring weight from an accurate zero starting point.
- The Auto zero value can be set to 0.5, 1, 2 or 4 scale divisions. The normal setting is 1 scale division. It will show "**A2 1d**".
- Press the **[Tare/↑]** key to change the value.
- Press the **[Zero/Enter]** key to store the changed setting and move to the next parameter.

7.6 SELECTABLE UNIT OF WEIGHT DISPLAYED

- The scales are normally set to display in kilograms, however they will show the weight in grams, if enabled.
- The display will show "**Ut on**" or "**Ut off**".
- Press **[Tare/↑]** to change the setting between **on** or **off**.
- Press the **[Zero/Enter]** key to store the changed setting and move to the next parameter.

CBWa Scales only:

The **CBWa** scales can change units from kilograms to grams, pounds or pounds/ounces immediately if they are enabled as in the step above. This also allows the scales to be calibrated in either kilograms or pounds and all memory accumulations are in either kilograms or pounds as last selected.

When the scales are set to display in other units the accumulation function is still keeping the weight in kilograms (or pounds for the **CBWa** series) in memory and will use the base weighing unit when printing over the RS-232 interface.

7.7 SETTING OF THE CHECK WEIGHING ALARM

- The display will show “**bEEP x**” where “**x**” is a digit from **0** to **2**.

0	will set the buzzer to off when check weighing
1	will set the buzzer to on when the OK symbol is on
2	will set the buzzer to on when the weight is outside the OK symbol limit

- To change this digit press the [**Tare/↑**] key.
- Press the [**Zero/Enter**] key to store the changed value and continue to the next parameter.

7.8 SPEED AT WHICH THE MACHINE WILL RUN THE ADC

- The slowest setting is **7.5** and the fastest is **60**. The default setting is usually **15**. The display will show “**SPd 15**”.
- To change this setting press the [**Tare/↑**] key.
- Press the [**Zero/Enter**] key to store the changed value and return to the normal weighing.

8.0 BATTERY OPERATION

- The scales can be operated from the battery, if desired. The battery life is approximately 70 hours.
- When the battery needs charging a symbol on the display will turn on. The battery should be charged when the symbol is on. The scale will still operate for about 10 hours after which it will automatically switch off to protect the battery.
- To charge the battery, simply attach the power supply module to the scale and plug in. The scale does not need to be turned on.
- The battery should be charged for 12 hours for full capacity.
- To the left of the display is a LED to indicate the status of battery charging. When the scale is plugged into the mains power the internal battery will be charged. If the LED is green the battery is being charged. If it is red it is nearly discharged and yellow indicates the battery is increasing the charge level. Continue to charge overnight for a complete re-charge.
- As the battery is used over the years it may fail to hold a full charge. If the battery life becomes unacceptable then contact your distributor or Adam Equipment.

9.0 RS-232 INTERFACE

The CBW scales can be ordered with an optional RS-232 output.

Specifications:

RS-232 output of weighing data
ASCII code
4800 Baud
8 data bits
No Parity

Connector:

9 pin d-subminiature socket
Pin 3 Output
Pin 2 Input
Pin 5 Signal Ground

Data Format for normal weighing operations, parts counting or recalling of totals from memory will all be different. Examples follow:

A. Normal Output

GS 1.234 kg
No. 1
Total 1.234 kg
<lf>
<lf>

GS for Gross weight, NT for net weight and a unit of weight
This number increments every time a new value is stored in memory
The total value stored in memory
Includes 2 line feeds

B. When in percent weighing mode, the output is shown in percent weight only

GS 100.00%
<lf>
<lf>

GS for Gross weight, NT for net weight and a unit of weight
Includes 2 line feeds

C. When in parts counting mode, the weight, unit weight and count will be printed-

GS	1.234 kg
U.W.	12.34 g/pcs
PCS	100 pcs
<lf>	
<lf>	

GS for Gross weight, NT for net weight and a unit of weight
The average piece weight computed by the scale
The number of parts counted
Includes 2 line feeds

D. When recalling the Total weight stored in the accumulation memory the output format is-

<lf>
TOTAL No. 5
Wt 21.456kg

A line of stars is shown
Includes 1 line feed

The total value stored in memory

9.1 INPUT COMMANDS FORMAT

The scale can be controlled with the following commands. The commands must be sent in upper case letters, i.e. "T" not "t". Press the Enter key of the PC after each command.

T<cr><lf>

Tares the scale to display the net weight. This is the same as pressing [Tare].

Z<cr><lf>

Sets the zero point for all subsequent weighing. The display shows zero.

P<cr><lf>

Prints the results to a PC or printer using the optional RS-232 interface. It also adds the value to the accumulation memory if the accumulation function is not set to automatic.

10.0 CALIBRATION

- The **CBW** scales are calibrated using metric weights and the **CBWa** scales can be calibrated using either metric or pound weights, depending on the weighing unit in use before calibration.
- To start calibration turn the scale off and then turn it on again. Press the **[Tare]** and **[%]** keys together once, during the initial counting from 9 to 0 on the display.
- The display will show "**UnLoAd**" for all models except CBW 6H /12aH. Remove all weight from the pan and then press the **[Zero/Enter]** key when the scale is stable. **Note: For CBW 6H/ 12aH**, it will show "**LoAd 0**" and when the scale is stable, it will ask for the calibration mass to be placed on the platform. For all other models, the display will show "**AdLoAd**". Place the suggested calibration mass on the pan. It is best to use a weight close to the full capacity of the scale.
- Press the **[Zero/Enter]** key. The display will then show the last mass used. If this is same as the mass on the pan then it can be used or a different value can be entered.
- To use this value, press the **[Zero/Enter]** key when the stable indicator is on.
- If a different value is desired, enter the value using the **[▶]** arrow key to select the flashing digit and the **[▲]** to increment the flashing digit. If value is correct, press the **[Zero/Enter]** key to accept when the stable indicator is on.
- Remove the calibration weight as the scale counts back from 9 to 0.
- If an error message "**FAIL H**" or "**FAIL L**" is shown during calibration, re-check the calibration and repeat, if necessary. If the error cannot be corrected contact your dealer or Adam Equipment for advice.

CBWa Scales only:

CBWa scales will also have the Lb or Kg (or g) indicator on to show the unit of the weight requested. If the scale was in pounds before starting the calibration, the weights requested will be in pound values. If the scale was weighing in kilograms then metric weights will be requested.

11.0 ERROR CODES

During the initial power-on testing or during operation, the scale may show an error message. The meaning of the error messages is described below.

If an error message is shown, repeat the step that caused the message. If the error message is still shown then contact your dealer for support.

ERROR CODE	DESCRIPTION	POSSIBLE CAUSES
Err 4	Initial Zero is greater than allowed (4% of maximum capacity) when power is turned on or when the [Zero/Enter] key is pressed.	Weight on the pan when turning the scale on. Excessive weight on the pan when zeroing the scale. Improper calibration of the scale. Damaged load cell. Damaged Electronics.
Err 5	Keyboard error.	Improper operation of the scale.
Err 6	A/D count is not correct when turning the scale on.	Platform is not installed. Load cell is damaged. Electronics is damaged.
Err 7	Scale is not stable when setting the percentage weighing.	The scale is not stable. Improper operation of the scale.
FAIL H or FAIL L	Calibration error.	Improper calibration (should be within $\pm 10\%$ of the factory calibration). The old calibration data will be retained until the calibration process is complete.
Err 9	Scale is unstable.	There is vibration or draft making the scale unstable. Electronics may be damaged.

To view the A/D count, press **[Zero/Enter]** and **[%]** at the same time while the scale is performing the initial check at power-on. Press **[Zero/Enter]** to return to normal weighing.

12.0 REPLACEMENT PARTS AND ACCESSORIES

If you need to order any spare parts and accessories, contact your supplier or Adam Equipment. A partial list of such items is as follows-

- Power Supply Module
- Main Power cord
- Replacement Battery
- Stainless Steel Pan
- In use cover
- RS-232 option
- Printer, etc.

13.0 SERVICE INFORMATION

This manual covers the details of operation. If you have a problem with the scale that is not directly addressed by this manual then contact your supplier for assistance. In order to provide further assistance, the supplier will need the following information which should be kept ready:

A. Details of your company

- Name of your company:
- Contact person's name:
- Contact telephone, e-mail, fax or any other methods:

B. Details of the unit purchased

(This part of information should always be available for any future correspondence. We suggest you to fill in this form as soon as the unit is received and keep a print-out in your record for ready reference.)

Model name of the scale:	CBW _____
Serial number of the unit:	
Software revision number (Displayed when power is first turned on):	
Date of Purchase:	
Name of the supplier and place:	

C. Brief description of the problem

Include any recent history of the unit. For example:

- Has it been working since it's delivered
- Has it been in contact with water
- Damaged from a fire
- Electrical Storms in the area
- Dropped on the floor, etc.

WARRANTY INFORMATION

Adam Equipment offers Limited Warranty (Parts and Labour) for the components failed due to defects in materials or workmanship. Warranty starts from the date of delivery.

During the warranty period, should any repairs be necessary, the purchaser must inform its supplier or Adam Equipment Company. The company or its authorised Technician reserves the right to repair or replace the components at the purchaser's site or any of its workshops depending on the severity of the problems at no additional cost. However, any freight involved in sending the faulty units or parts to the service centre should be borne by the purchaser.

The warranty will cease to operate if the equipment is not returned in the original packaging and with correct documentation for a claim to be processed. All claims are at the sole discretion of Adam Equipment.

This warranty does not cover equipment where defects or poor performance is due to misuse, accidental damage, exposure to radioactive or corrosive materials, negligence, faulty installation, unauthorised modifications or attempted repair or failure to observe the requirements and recommendations as given in this User Manual.

Repairs carried out under the warranty does not extend the warranty period. Components removed during the warranty repairs become the company property.

The statutory right of the purchaser is not affected by this warranty. The terms of this warranty is governed by the UK law. For complete details on Warranty Information, see the terms and conditions of sale available on our web-site.



Manufacturer's Declaration of Conformity

This product has been manufactured in accordance with the harmonised European standards, following the provisions of the below stated directives:

Electro Magnetic Compatibility Directive 89/336/EEC

Low Voltage Directive 73/23/EEC

Adam Equipment Co. Ltd.
Bond Avenue
Denbigh East Estate
Milton Keynes, MK1 1SW
United Kingdom

FCC COMPLIANCE

This equipment has been tested and found to comply with the limits for a Class A digital device, pursuant to Part 15 of the FCC Rules. These limits are designed to provide reasonable protection against harmful interference when the equipment is operated in a commercial environment. The equipment generates, uses, and can radiate radio frequency energy and, if not installed and used in accordance with the instruction manual, may cause harmful interference to radio communications. Operation of this equipment in a residential area is likely to cause harmful interference in which case the user will be required to correct the interference at his own expense.

Shielded interconnect cables must be employed with this equipment to insure compliance with the pertinent RF emission limits governing this device.

Changes or modifications not expressly approved by Adam Equipment could void the user's authority to operate the equipment.

ADAM EQUIPMENT is an ISO 9001:2000 certified global organisation with more than 30 years experience in the production and sale of electronic weighing equipments. Products are sold through a world wide distributor network -supported from our company locations in the UK, USA, SOUTH AFRICA and CHINA. The company and their distributors offer a full range of Technical Services such as on site and workshop repair, preventative maintenance and calibration facilities.

ADAM's products are predominantly designed for the Laboratory, Educational, Medical and Industrial Segments. The product range can be classified as follows:

- Analytical and Precision Laboratory Balances
- Top Loading Balances for Educational establishments
- Counting Scales for Industrial and Warehouse applications
- Digital Weighing/Check-weighing Scales
- High performance Platform Scales with extensive software features including parts counting, percent weighing etc.
- Digital Electronic Scales for Medical use
- Retail Scales for price computing

© Copyright by Adam Equipment Co. Ltd. All rights reserved. No part of this publication may be reprinted or translated in any form or by any means without the prior permission of Adam Equipment.

Adam Equipment reserves the right to make changes to the technology, features, specifications and design of the equipment without notice.

All information contained within this publication was to the best of our knowledge timely, complete and accurate when issued. However, we are not responsible for misimpressions which may result form the reading of this material.

The latest version of this publication can be found on our Website.