

ELP-362D90

Underwater Locator Beacon

User's Manual

June 2015
P/N: 362-17001-D
REV. F



RJE INTERNATIONAL, INC.

RJE INTERNATIONAL, INC.
15375 Barranca Parkway Suite I-112
Irvine, California, 92618 U.S.A.
www.rjeint.com

Tel: +1-949-727-9399
Fax: +1-949-727-0070
e-mail: aviationsales@rjeint.com

Preface

This manual describes the installation and operation of the ELP-362D90: P/N ELP-362D90 Underwater Locator Beacon, water-activated acoustic beacons designed for use on aircraft flight recorders. This manual is divided into the following six sections:

- 1 Description**
- 2 Specifications**
- 3 Installation and Checkout**
- 4 Beacon Maintenance**
- 5 Return Procedures**
- 6 Warranty**

Proprietary Information

The information, description, and illustrations in this manual are the property of RJE International, Inc. Materials may not be reproduced or disseminated without the prior written consent of RJE International, Inc.

Changes

RJE International, Inc. reserves the right to make changes to meet new specifications at any time without incurring any obligation to modify previously installed units. This manual is provided for informational and reference purposes only and is subject to change without notice.

Notes and Warnings

Where applicable, special notes and warnings are presented as follows:

NOTE: A reminder to check that certain criteria are met before proceeding further in a step or sequence.



WARNING: A reminder that dangerous consequences could result if certain recommended procedures are not followed.

Table of Contents

1	Description	1
	External Construction	2
	Internal Construction	3
	Theory of Operation	3
	Locating the Beacon	3
2	Specifications	4
	General Specifications	4
	TSO Testing Qualification Summary	5
3	Installation and Checkout	6
	Installation Considerations	6
	Installation Procedures	7
	Pre-Deployment Tests	9
	<i>ATS-260 Acoustic Test Set</i>	9
	<i>ATS-260 Acoustic Test Set Service</i>	10
	<i>Alternative Battery Check</i>	11
4	Beacon Maintenance	12
	Beacon Cleaning	12
	Periodic Beacon Test	12
	Beacon Maintenance Precautions	12
	Battery Maintenance	13
	<i>Tooling Requirements</i>	13
	<i>Torque Requirements</i>	14
	Beacon Disposal	15
	Battery Replacement Instructions	16
	Return Procedures	17
6	Warranty	18
7	Record of Revision	19

List of Figures

<i>Figure 1-1 ELP-362D90 and Mounting Bracket.....</i>	<i>1</i>
<i>Figure 1-2 ELP-362D90 Installed in Mounting Bracket.....</i>	<i>2</i>
<i>Figure 1-3 ELP-362D90 Dimensions.....</i>	<i>2</i>
<i>Figure 1-4 Locating the Aircraft After Water Activation.....</i>	<i>3</i>
<i>Figure 3-1 Mounting Bracket Hole Pattern</i>	<i>7</i>
<i>Figure 3-2 Securing the Mounting Bracket</i>	<i>8</i>
<i>Figure 3-3 Installing the Beacon into the Mounting Bracket</i>	<i>8</i>
<i>Figure 3-4 Connecting the ATS-260 Acoustic Test Set.....</i>	<i>10</i>

1 Description

The ELP-362D90 Underwater Locator Beacon is a durable, water-activated, underwater location aid. The beacons transmit an acoustic signal at 37.5 kHz once every second after activation. The acoustic output for the beacon will remain above 157.0 dB for 90 days.

The ELP-362D90 Underwater Locator Beacon with 90 day battery life meets the performance specifications of RTCA/DO-160G, as required by TSO-C121b.

RJE International, Inc. also offers both a standard mounting bracket kit (P/N B362-05591) and a customer specific mounting bracket kit (P/N B362-08320). Either kit allows the beacon to be securely mounted (Please contact RJE International, Inc. if the standard mounting bracket does not meet your needs). The beacon and its standard mounting bracket are shown in Figure 1-1. The beacon is also shown installed in its standard mounting bracket in Figure 1-2, and a dimensional outline of the beacon is shown in Figure 1-3.

This section provides a general descriptive overview of the beacon, its theory of operation, and use.

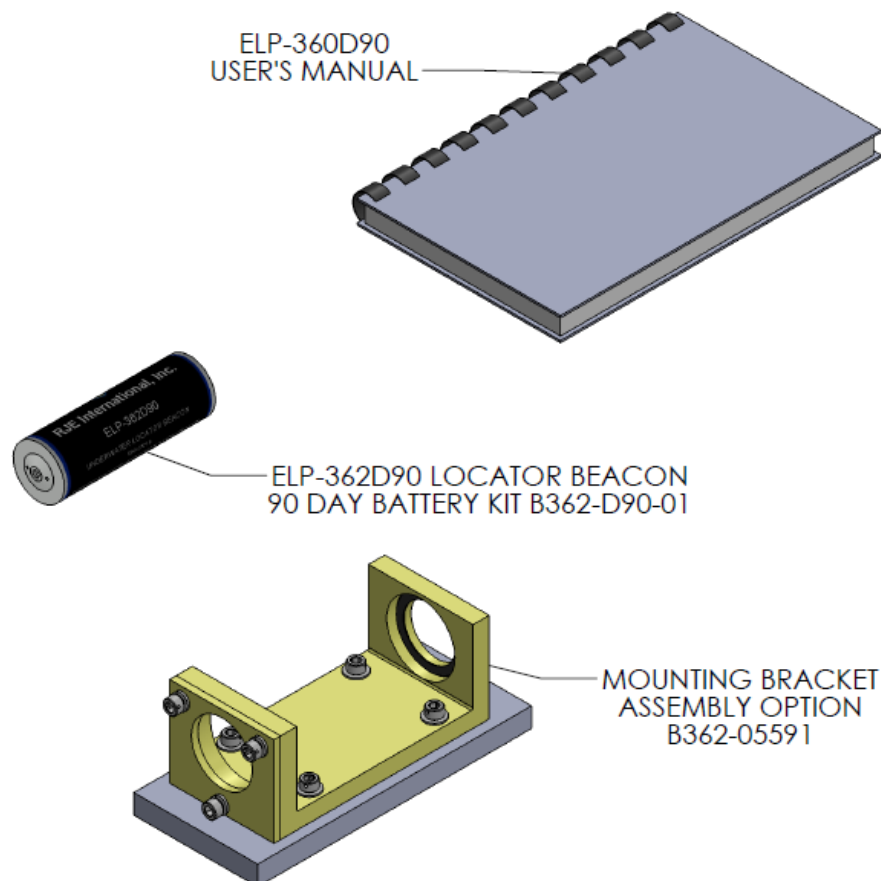

Figure 1-1 ELP-362D90 and Mounting Bracket

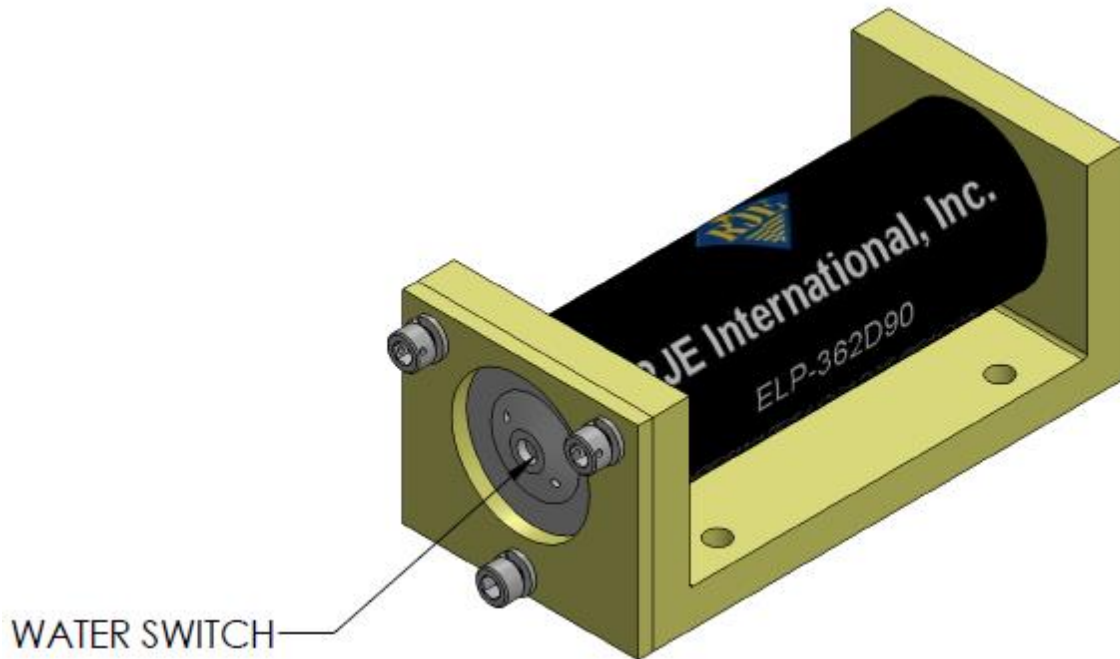

Figure 1-2 ELP-362D90 Installed in Mounting Bracket

External Construction

The beacon is contained in a water-tight aluminum case capable of withstanding high-impact shock and deep-water immersion. As shown in Figure 1-2, one of the end caps has a water-activated built in switch that causes the beacon to begin transmitting when the switch comes in contact with water.



Figure 1-3 ELP-362D90 Dimensions

Internal Construction

The major internal components of the beacon include a printed circuit board assembly, a urethane-encapsulated transducer assembly, and a battery. The battery is contained in its own, separate, user accessible compartment.

Theory of Operation

The printed circuit board assembly generates all the necessary logic functions to produce a pulse with the desired characteristics. The pulse is then transformed from a CMOS level square wave to a much larger 37.5 kHz sinusoidal pulse by a transformer. The output of the transformer drives the urethane-encapsulated transducer, which propagates through the housing in the form of a tuned 37.5 kHz acoustic signal.

Locating the Beacon

When the beacon is immersed in water, it will begin to radiate an acoustic signal which can be received and transformed into an audible signal by the RJE International, Inc. PRS-275, DPR-275 or DTI-300 Acoustic Pinger Receivers. The PRS-275 Pinger Receiver can be used as a shipboard portable receiver to determine the general vicinity of the aircraft flight recorder. After the area is known, a diver can be deployed with the DPR-275, which will give the exact location of the aircraft flight recorder. Other equivalent pinger receivers may also be used.

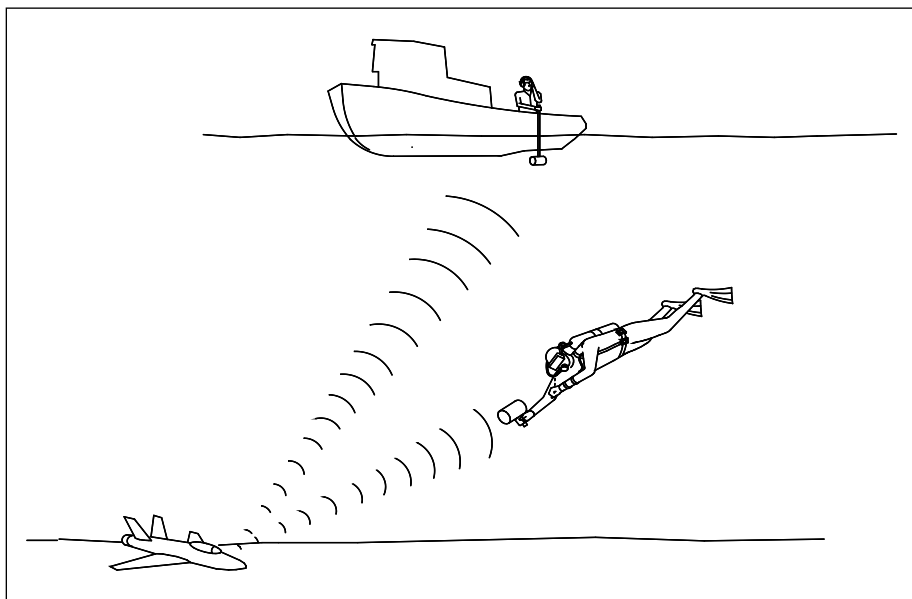

Figure 1-4 Locating the Aircraft After Water Activation

2 Specifications

This section provides information on the operating and environmental specifications on the ELP-362D90 Underwater Locator Beacon.

General Specifications

Specifications

ELP-362D90

Operating Frequency:	37.5 kHz, \pm 1 kHz
Operating Depth:	0 to 20,000 feet (6,096 meters)
Pulse Length:	\geq 9 ms
Battery Kit:	P/N B362-D90-01 Incl. battery, o-ring, lube & inst.
Operating Life:	\geq 90 days
Battery Storage Life in Beacon:	7 years
Acoustic Output:	\geq 160.5 dB re 1 μ Pa @ 1 meter
Acoustic Output After 90 Days:	\geq 157.0 dB re 1 μ Pa @ 1 meter
Activation:	Fresh or salt water immersion
Beam Pattern:	80% sphere
Case Size:	1.30 in. (3.30 cm) diameter 3.92 in (10 cm) long
Case Material:	7075 T6 aluminum
Weight:	6.78 oz. (192g) Maximum
Storage Temperature:	-55°C (-67°F) to 71°C (160°F)
Operating Temperature:	-2°C (28°F) to 38°C (100°F)

TSO Testing Qualification Summary

The beacon is designed to meet the performance specifications of RTCA/DO-160G, as required by TSO-C121b. A summary of the testing qualifications is presented in the table below.

ELP-362D90 Testing Qualification Summary		
Testing Conditions	RTCA DO-160G Section No.	Description of Test Conducted
Altitude	4.6.1	Equipment tested to Category D2 (50,000 ft.)
Decompression	4.6.2	
Overpressure	4.6.3	
Temperature Variation	5.0	Equipment tested to category A
Vibration	8.0	Equipment tested to RTCA DO-160G Figure 8-4 Curve C (Fixed Wing) and Figure 8-2b Curve U2 (Rotary Wing)
Sand and Dust	12.0	Equipment tested to Category S
Fungus	13.0	Equipment tested to Category F
Salt Spray	14.0	Equipment tested to Category S
Magnetic Effect	15.0	Equipment tested to Category Z
Induced Signal Susceptibility	19.0	Equipment tested to category ZC
Other Tests	–	Performance, environmental and Crash Survivability Testing performed as required by AS8045a.

Limitations:

This article meets the minimum performance and quality control standards required by TSO-C121b. Installation of this article requires separate approval.

Additional Testing to Support Installation of Lithium Battery

This article has been tested to TSO-C142a Appendix 1 Table 2 and shown to contain all venting, smoke, fire, and explosions caused by ignition of internal battery. Any ignition within the article has been shown to be self-extinguishing.

3 Installation and Checkout

This section encompasses the installation considerations and procedures for mounting the beacon using the mounting bracket kit, and a pre-deployment test that can be conducted using a RJE International, Inc. ATS-260 Acoustic Test set.

Installation Considerations

To minimize the probability of physical damage or inadvertent activation, the following precautions should be considered when mounting the beacon:

- *The beacon should normally be mounted in the aft mid-section of the aircraft depending on the environmental conditions and should be mounted to a sturdy structure without weakening the structure itself.*
- *The beacon should be mounted in an area guarded against heavy equipment tearing loose and striking the beacon and should be mounted in a way that provides convenient access during regular inspections and tests.*
- *The beacon should be mounted in a clean, dry area to decrease the probability of inadvertent activation. Also, if possible, the beacon should be mounted with the water switch facing down to minimize the possibility of moisture gathering on the end cap.*
- *The beacon should be mounted in an area that is protected from the outside elements. This will assist in the long-term prevention of corrosion.*
- *The beacon should be mounted in an area where sound absorbent materials are not present. Avoid affixing labels to the beacon or any other material that would affect the acoustic beam.*
- *The shelf life of the battery will be decreased when exposure to higher than normal temperatures. The maximum temperature where the beacon is mounted should not exceed 71°C (160° F).*
- *Nonconformance to the mounting instructions or intended use may void the warranty.*

Installation Procedures

Carefully unpack the beacon and inspect it for shipping damage. If any damage is evident, it should be reported to the freight carrier and to RJE International, Inc. The mounting bracket kit includes an aluminum mounting bracket, an aluminum end plate, three drilled (for lockwire) socket head cap screws, and three lock washers.

NOTE: Before installing the mounting bracket, be sure that it will be possible to install and remove the beacon once the bracket is installed.

To mount the beacon, perform the following steps:

1. Refer to the mounting bracket hole pattern shown in Figure 3-1 and drill four 0.191 in (0.48 cm) diameter holes.
2. Secure the mounting bracket with four 10-32 stainless steel screws and associated hardware (not supplied) as shown in Figure 3-2.
3. Slide the beacon into the bracket as shown in Figure 3-3. Rotate the beacon until the battery date is visible and secure it in place with the end plate and the three drilled socket head cap screws.
4. Lockwire the drilled screws and clean the water activation switch (refer to section 4 Beacon Cleaning).

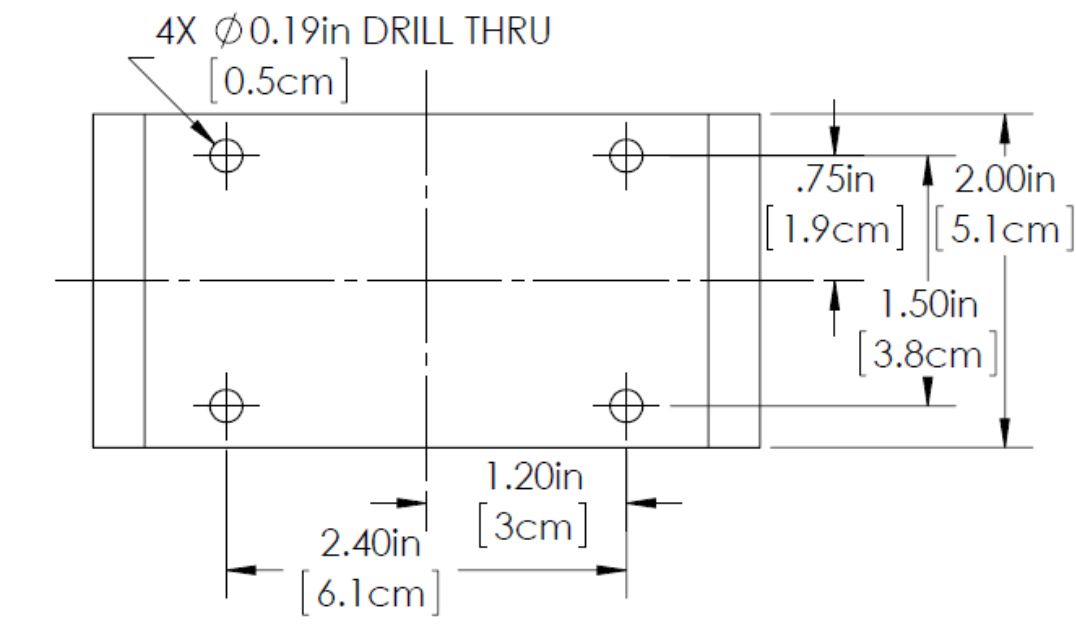

Figure 3-1 Mounting Bracket Hole Pattern

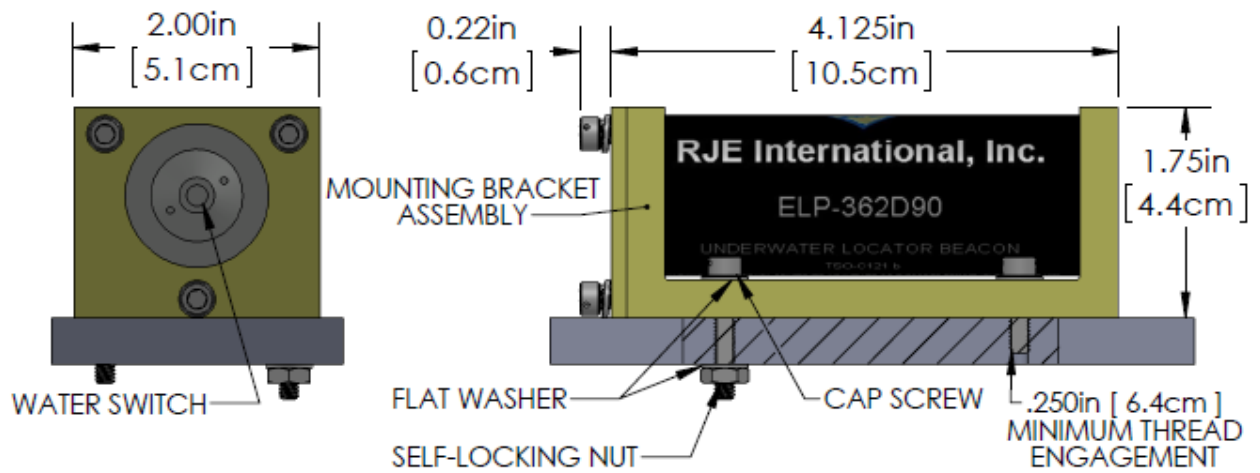

Figure 3-2 Securing the Mounting Bracket

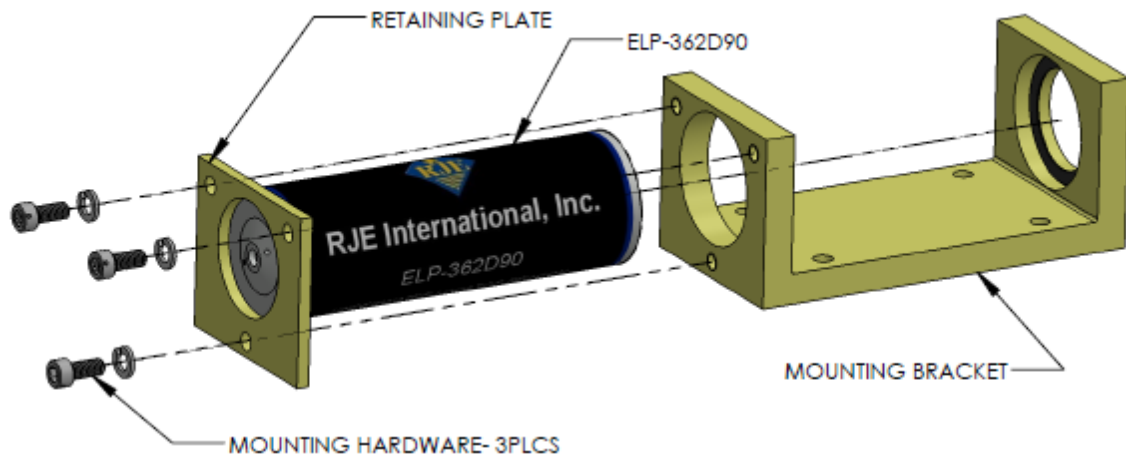

Figure 3-3 Installing the Beacon into the Mounting Bracket

Pre-Deployment Tests

A pre-deployment test on each beacon should be performed before and after mounting using the RJE International, Inc. ATS-260 Acoustic Test Set. The test set can be used to check both the beacon's battery condition and operation. Also, an alternative method using a digital voltmeter can be used to check the beacon's battery condition.

ATS-260 Acoustic Test Set

To use the ATS-260 Acoustic Test Set to verify the battery condition and test the operations of the beacon, use the following procedure:

1. Attach the cable clip directly to the beacon housing as shown in Figure 3-4. It is not necessary to remove the beacon from the mount to conduct the test. Although the cable clip can touch the beacon label, it is important that at least part of the clip touch the bare aluminum surface of the beacon.
2. Apply the test set probe to the water activation switch as shown in Figure 3-4.
3. Hold down the button labeled **PUSH TO TEST** on the test set handle.
4. Check the beacon battery condition by observing the green and red indicators on the test set.

If the green indicator is lit, the battery is good.

***If the red indicator is lit, the battery should be replaced.
(See Section 3 Alternate Battery Check)***

5. Check the beacon operating condition by listening for an audible tone from the test set and /or observing the amber indicator.

If there is an audible tone and /or the amber indicator is flashing, the beacon is operating properly.

If there is no audible tone and the amber indicator is not flashing, the beacon is not operating properly.

NOTE: If the beacon does not operate properly, return it RJE International, Inc. for service. (See Section 5 *Return Procedures* for instructions on how to return the beacon.)

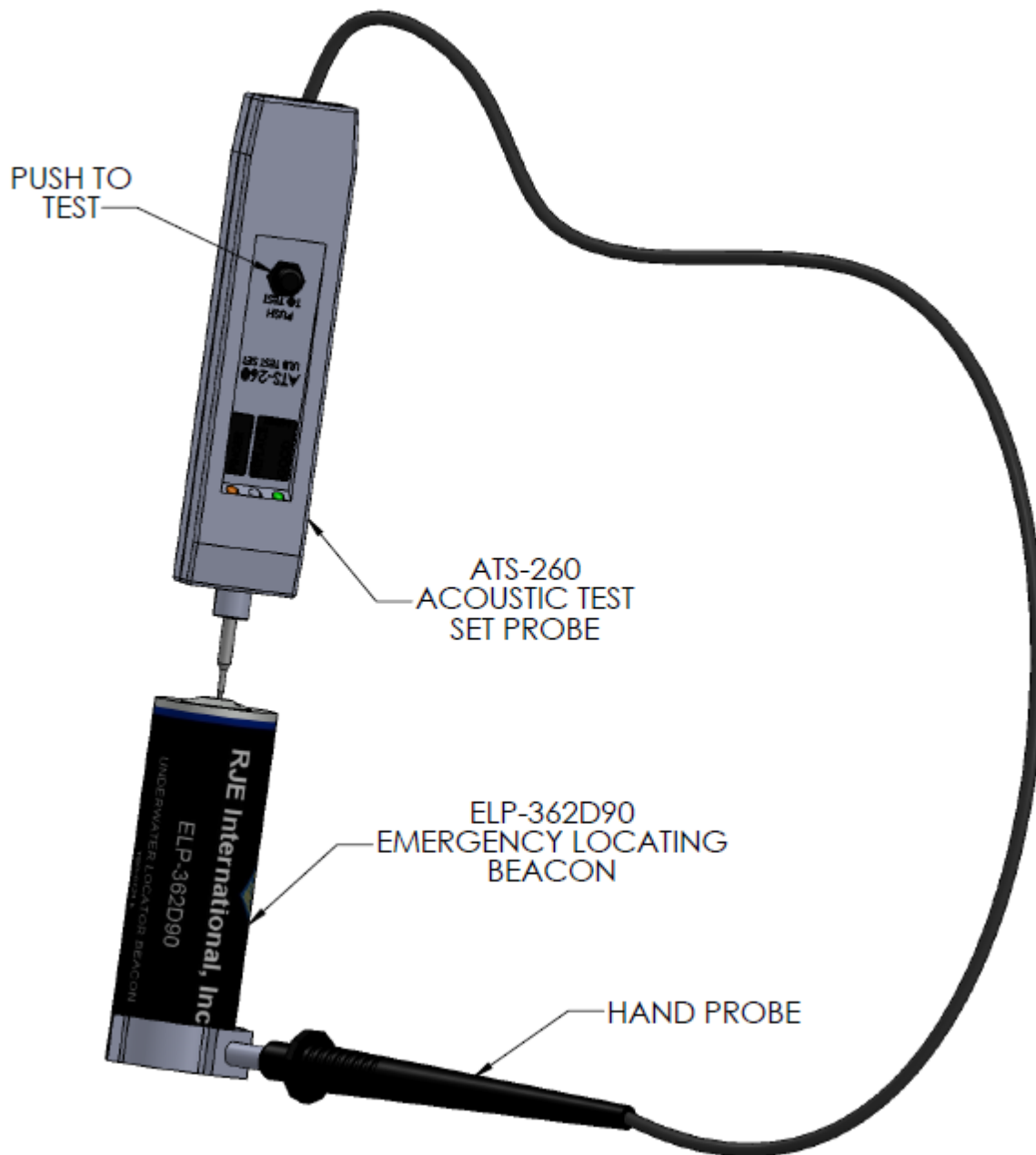

Figure 3-4 Connecting the ATS-260 Acoustic Test Set

ATS-260 Acoustic Test Set Service

The ATS-260 Acoustic Test Set is factory calibrated at the date of manufacture, and requires recalibration every 3 years. Return test set to RJE International, for calibration. (See Section 5 *Return Procedures* for instructions on how to return the test set.)

Alternative Battery Check

In addition to using the test set to check the beacon's battery condition, a high-impedance (minimum input impedance of 10 Megohms) digital voltmeter can be used to measure the battery voltage. Use the following procedure to measure the battery voltage:

1. Place the negative meter lead on the water activation switch.
2. Place the positive meter lead on the bare aluminum surface of the beacon housing. Do not place the meter lead on the label.
3. Read the voltmeter.

If the voltmeter reading is 6.0 volts or more, the beacon has sufficient operating power.

If the voltmeter reading is less than 6.0 volts, DO NOT remove the battery access end cap. (See Section 5 Return Procedures for instructions on how to return the beacon.)



WARNING: Failure to observe these precautions could result in the release of hazardous chemicals.

4 Beacon Maintenance

This section covers the cleaning, recommended testing interval, disposal, storage procedures, and battery replacement for the ELP-362D90 Underwater Locator Beacon.

Beacon Cleaning

The end cap with the water switch and the end cap with the exposed stainless steel contact, should remain free and clear of dirt, grease, and dust. The end caps should be cleaned with a mild detergent and dried thoroughly with a clean cloth. This process should be repeated periodically depending on the local environment.

Periodic Beacon Test

When the beacon is installed on a flight data or voice recorder, the recommended maintenance interval is the same as that of the recorder, or 24 months, whichever is shortest. Follow the *Pre-Deployment Tests* referenced in Section 3 of this User's Manual.

Beacon Maintenance Precautions

The following precautions should be exercised when handling or storing the beacon:

- ***The beacon/battery should not be exposed to temperatures in excess of 71°C (160°F), as the battery life can be reduced by storage in a high temperature environment.***
- ***Any situation that could possibly crush or penetrate the case of the beacon should be avoided.***

Battery Maintenance

Replace the battery by the date stamped on the beacon label, where the three letters represent the month, and the four numbers represent the year.

Example: MAR2022 is March of 2022

Other date codes prior to this manual revision include the following:

1. Three letters represent the month and two numbers represent the year:

Example: MAR 22 is March of 2022

2. Two numbers to the left of a “/” represent the month and two numbers to the right of the “/” represent the year

Example: 03/22 is March of 2022



WARNING: Hazardous chemicals are used in the beacon battery. Dispose of the battery in accordance with local regulations.



WARNING: If Battery shrink sleeve is damaged/removed exposing paper label or if battery is physically damaged. **DO NOT INSTALL BATTERY.**

Use the battery replacement procedure provided with the lithium battery replacement kit P/N B362-D90-01. Battery replacement should be performed by authorized personnel only.

Tooling Requirements

Item	Manufacturer	Model Number
Torque Wrench	Commercially Available	-----
1/2" Socket	Commercially Available	-----
Torque Adapter	RJE International, Inc.	B362-09111
ATS-260 Test Set	RJE International, Inc.	ATS-260

Torque Requirements

Location	Torque
Bottom End Cap	25 to 30 inch pounds (2.7 to 3.4 newton meters).

Parts List

Item	Part Number	Quantity
ELP-362D90 Beacon	ELP-362D90	1
Battery Replacement Kit	B362-D90-01	1
Battery Pack	362-99000-1	1
O-Ring	362-69001	1
Lubricant Tube	999-00026	1
Instructions	362-19001-3	1
Label 90 DAY BATTERY MMM YY LL	362-59002	1

Periodic Battery Storage Maintenance

When battery is stored, it is recommended maintaining 12 month maintenance interval to check battery voltage and proper storage conditions. To check Battery Voltage use a high-impedance (minimum input impedance of 10 Megohms) digital voltmeter.

If the voltmeter reading is 7.2 volts or less battery is not recommended for installation.

Battery Storage Guidelines

Cells should be stored in their original containers. Store cells in a well ventilated, cool, dry area. Cells should be placed in an isolated area, away from combustible materials. Never stack heavy objects on top of boxes containing lithium batteries to preclude crushing or puncturing the cell case.

Beacon Disposal

If it is necessary to dispose of the beacon, perform the Alternative Battery Check referenced in Section 3 of this User's Manual first.

If the battery voltage is 6.0 volts or more, remove the battery and dispose of the battery and beacon in accordance with local regulations.

If the battery voltage is less than 6.0 volts, DO NOT remove the battery access end cap and dispose of the beacon in accordance with local regulations.



WARNING: Failure to observe these precautions could result in the release of hazardous chemicals.

Beacon Storage

When long-term storage is required, the beacon should be stored in a cool, dry environment in its original shipping container.

Battery Replacement Instructions



RJE International 15375 Barranca Pkwy. Ste. 1-112, Irvine, CA 92618, USA

ELP-362D90 UNDERWATER LOCATOR BEACON
OPTIONAL BATTERY REPLACEMENT KIT (B362-D90-01) INSTRUCTIONS

Battery Manufacture Date Battery Expiration Date

The battery replacement kit includes a lithium battery P/N 362-99000-1, O-Ring P/N 362-69001, O-Ring lubricant tube P/N 999-00026, replacement instructions P/N 362-19001-3, and 90 DAY BATTERY MMM YY LL label P/N 362-59002.

Battery replacement must be conducted by the latest date stamped on the pinger label.

Remove the ELP-362D90 from the mounting bracket assembly and perform the "Alternative Battery Check" as described in the ELP-362D90's User's Manual found in Section 3 under "Pre-Deployment Tests."

If the measured voltage is less than 6.0 Volts, **DO NOT** remove the battery access end-cap. Return the ELP-362D90 to RJE International for service.

! WARNING: Failure to observe these precautions could result in the release of hazardous chemicals.

If the measured voltage is 6.0 Volts or more, proceed with the following battery replacement instructions.

STEP A: Using the RJE International torque adapter, B362-09111, remove the end-cap marked "BATTERY ACCESS".

! WARNING: Do not clamp the pinger in a vice!

STEP B: Invert the housing to remove the old battery from the unit. Dispose of the expanded cell in accordance with local regulations.

! WARNING: Never attempt to recharge the battery! Serious personal injury could result.

STEP C: Inspect the interior of the ELP-362D90 housing for evidence of leaking or corrosion and inspect all threads for any signs of damage.

! WARNING: Always keep both the housing and end-cap threads free of dirt, lint, etc.

STEP D: Install the new battery, part number 362-99000-1. Note that the battery label is marked with an arrow. Insert the battery so the arrow points towards the top (water turn-on) end of the unit

STEP E: Remove the O-Ring from its groove in the end-cap. Clean O-Ring groove of any dirt, lint, debris, etc. Liberally apply the O-Ring lubricant to the new O-Ring and place the lubricated O-Ring in the end-cap groove. *Note: Use only lubricant provided with battery kit. **DO NOT SUBSTITUTE ANY OTHER LUBRICANT.**

STEP F: Re-fasten the end-cap to the housing. Use the RJE International torque adapter to seat the end-cap snugly. Torque end-cap to 25 to 30 inch pounds (2.7 to 3.4 newton meters).

STEP G: Affix the **90 DAY BATTERY: MMM YY LL** label included with the kit to beacon, below existing label. Do not apply more than three labels on unit. Contact RJE for instructions if more than three labels are present.

! WARNING: Do not cross-thread or apply excessive force to the end-cap.

PLEASE CONTACT RJE INTERNATIONAL. FOR ANY QUESTIONS OR RETURNS
 RJE International Inc. Tel: (949) 727-9399, Fax: (949) 727-0070, e-mail: aviationsales@rjeint.com
 RETURNS: Please have return reason, quantity and serial number of the ELP-362D90 ready. **DO NOT SHIP** the ELP-362D90 without receiving a Return Material Authorization.

P/N 362-19001-3 Rev C 6/9/15

Figure 4-1 Standard Battery Kit Replacement Instructions

5 Return Procedures

If you need to return an ELP-362D90 Underwater Locator Beacon for warranty service, contact RJE International, Inc. for a **Return Material Authorization (RMA)** number and shipping instructions.

RJE International, Inc.
Tel: +1-949-727-9399
Fax: +1-949-727-0070
e-mail: aviationsales@rjeint.com

You will need to provide the following information to receive a **Return Material Authorization (RMA)**:

- Reason for return
- Number of beacons to be returned
- Serial number of each unit
- Shipping method, if applicable

NOTE: Do not ship a beacon without a **Return Material Authorization**.

6 Warranty

LIMITED WARRANTY. RJE International, Inc. warrants that the products sold hereunder shall be free from defects in materials and workmanship under normal use and service when correctly installed, used and maintained for a period of 84 months from date of shipment from RJE International, Inc. Purchaser's receipt of any product delivered hereunder shall be an unqualified acceptance of and a waiver by Purchaser of the right of Purchaser to make a claim with respect to such product unless Purchaser gives RJE International, Inc. notice of any claim within 84 months after the receipt of such product. This warranty is limited to repair or replacement of the said product at RJE International, Inc. plant in Irvine, California, providing the product was not abused or operated other than in accordance with the RJE International, Inc. instruction manuals. RJE International, Inc. does not assume responsibility for any damage due to leakage or implosion. RJE International, Inc. reserves the right to modify its warranty at any time, in its sole discretion. THIS LIMITED WARRANTY IS NOT TRANSFERABLE.

LIMITATION OF LIABILITY. RJE INTERNATIONAL, INC. MAKES NO OTHER WARRANTY REGARDING ITS PRODUCTS OR THE PRODUCTS OF OTHERS EITHER EXPRESS OR IMPLIED; AND, ANY IMPLIED WARRANTY OF MERCHANTABILITY OR FITNESS FOR A PARTICULAR PURPOSE WHICH EXCEEDS THE FORGOING WARRANTIES IS HEREBY DISCLAIMED BY RJE INTERNATIONAL, INC. AND EXCLUDED FROM ANY AGREEMENT MADE BY ACCEPTANCE OF ANY ORDER. RJE INTERNATIONAL, INC. DOES NOT ACCEPT LIABILITY BEYOND THE REMEDIES SET FORTH HEREIN INCLUDING ANY LIABILITY FOR PRODUCTS NOT BEING AVAILABLE FOR USE OR FOR LOST OR CORRUPTED DATA, LOSS OF BUSINESS, LOSS OF PROFITS, LOSS OF USE OF THE PRODUCT OR ANY ASSOCIATED EQUIPMENT, COST OF CAPITAL, COST OF SUBSTITUTE OR REPLACEMENT PRODUCT, FACILITIES OR SERVICES, DOWN-TIME, CHARGES FOR PURCHASER'S TIME AND EFFORT, THE CLAIMS OF THIRD PARTIES, INJURY TO PROPERTY, OR ANY OTHER DIRECT, INDIRECT, SPECIAL, RELIANCE, INCIDENTAL OR CONSEQUENTIAL DAMAGES, REGARDLESS OF THE NATURE OF THE CLAIM AND WHETHER OR NOT FORESEEABLE AND WHETHER OR NOT BASED ON BREACH OF WARRANTY, CONTRACT OR TORT (INCLUDING NEGLIGENCE) OR STRICT LIABILITY, EVEN IF RJE INTERNATIONAL, INC. HAS BEEN ADVISED OF THE POSSIBILITY OF SUCH DAMAGES, OR FOR ANY CLAIM BY ANY THIRD PARTY EXCEPT AS EXPRESSLY PROVIDED HEREIN.

THIS LIMITATION OF LIABILITY APPLIES BOTH TO PRODUCTS AND SERVICES AND SUPPORT PROVIDED PURCHASER UNDER THIS AGREEMENT. NO ORAL OR WRITTEN INFORMATION OR ADVICE GIVEN BY RJE INTERNATIONAL, INC., ITS AGENTS OR EMPLOYEES SHALL CREATE A WARRANTY OR IN ANY WAY INCREASE THE SCOPE OF THE LIMITED WARRANTY PROVIDED ABOVE. ANY AND ALL LIABILITY OF RJE INTERNATIONAL, INC. IS EXPRESSLY LIMITED TO THE PRICE PURCHASER HAS PAID FOR THE PRODUCTS. PURCHASER'S SOLE REMEDY AGAINST RJE INTERNATIONAL, INC. IN ANY DISPUTE UNDER THIS AGREEMENT SHALL BE TO SEEK RECOVERY OF THE AMOUNTS PURCHASER PAID, PURSUANT TO THE LIMITED WARRANTY PROVIDED ABOVE, UPON THE PAYMENT OF WHICH RJE INTERNATIONAL, INC., ITS AGENTS AND EMPLOYEES, AND AFFILIATES, WILL BE RELEASED FROM AND DISCHARGED OF ALL FURTHER OBLIGATIONS AND LIABILITY TO PURCHASER.

THE LIMITED WARRANTY OF RJE INTERNATIONAL, INC. GIVES PURCHASER SPECIFIC LEGAL RIGHTS, AND PURCHASER MAY ALSO HAVE OTHER RIGHTS THAT VARY FROM STATE TO STATE. SOME STATES DO NOT ALLOW LIMITATIONS ON HOW LONG AN IMPLIED WARRANTY LASTS OR THE EXCLUSION OR LIMITATION OF INCIDENTAL OR CONSEQUENTIAL DAMAGES, SO THE ABOVE LIMITATIONS OR EXCLUSIONS MAY NOT APPLY TO PURCHASER.

7 Record of Revision

Revision	Date	Section	Paragraph	Summary of change	Authorized by
A	07/18/14			Initial issue	S. Cole
B	09/30/14	4	6	Battery Storage	S. Cole
C	01/19/15	4	4	Revised Torque and Parts list	S. Cole
		4	F-1	Addition Battery Installation Kit Instructions	S. Cole
		7	1	Addition of Record of Revision	S. Cole
D	01/23/15	2	3	Additional Testing to Support Battery Install	S. Cole
E	02/22/15	1, 3, 4	Figures Battery Instructions	Revised to show new label	S. Cole
F	06/05/15	2	1 and 2	Revised Beacon Specification	S. Cole
		4	Figure 4-1	Revised Battery Instructions	S. Cole