



**TACOMA HV SERIES
1K ~ 3KVA
On-Line UPS**

USER MANUAL

Maruson Technology Corporation

P.O. Box 1986, Walnut, CA 91788 USA

Toll Free: 1-888-MARUSON

Website: www.MarusonUSA.com | E-Mail: Info@MarusonUSA.com

**Copyright © 2012 All Rights Reserved. Maruson® is a registered trademark of Maruson Technology (U.S. Trademark Reg. No. 3,150,957). All other trademarks are the property of their respective owners. Product specifications are subject to change without notice. Battery backup time is based on half load and varies with equipment, configuration, battery age, temperature, etc.*

CONTENT

1. Safety and EMC Instructions	1
1.1 Installation.....	1
1.2 Operation.....	2
1.3 Maintenance, servicing and faults.....	3
1.4 Transport.....	4
1.5 Storage	4
1.6 Standards.....	5
2. Description of Commonly Used Symbols	6
3. Introduction	7
4. Panel Description	8
5. Connection and Operation	12
5.1 Inspection:	12
5.2 Connection:.....	12
5.3 Battery charge:	14
5.4 Turn on the UPS:	14
5.5 Test function:.....	15
5.6 Turn off the UPS:	15
5.7 Audible alarm mute function:	16
5.8 Operation procedure of external battery for long backup time model ("L" model)	16
6. Operating Mode for All Models	18
6.1 Line mode	18
6.2 Battery mode	19
6.3 Bypass mode	21
6.4 NO output mode	21
6.5 EPO (Emergency Power Off)	22

6.6 ECO mode (Economy mode)	22
6.7 Converter mode	23
6.8 Abnormal mode	23
7. Setting by LCD Module	24
8. Trouble Shooting	27
9. Maintenance	31
9.1 Operation	31
9.2 Storage	31
9.3 Battery Replace	31
10. Technical Data	32
10.1 Electrical specifications	32
10.2 Operating Environment	32
10.3 Typical backup time (Typical values at 25°C in minutes:)	33
10.4 Dimensions and weights	33
11. Communication Port	34
11.1 USB	34
11.2 AS400 Interface (Option)	34
12. Software	35
Appendix: Rear panel	36

1. Safety and EMC Instructions

Please read carefully the following user manual and the safety instructions before installing the unit or using the unit!

1.1 Installation

- ★ See installation instructions before connecting to the supply.
- ★ Condensation may occur if the UPS is moved directly from a cold to a warm environment. The UPS must be absolutely dry before being installed. Please allow an acclimatization time of at least two hours.
- ★ Do not install the UPS near water or in damp environment.
- ★ Do not install the UPS where it would be exposed to direct sunlight or near heat.
- ★ Do not connect appliances or items of equipment which would overload the UPS (e.g. laser printers, etc) to the UPS output.
- ★ Place cables in such a way that no one can step on or trip over them.
- ★ Assure to connect with the earth reliably.
- ★ Assure external battery source must be earthed.
- ★ Connect the UPS only to an earthed shockproof socket outlet.
- ★ The building wiring socket outlet (shockproof socket outlet) must be easily accessible to close to the UPS.
- ★ With the installation of the equipment, the sum of the leakage current of the UPS and the connected load does not exceed 3.5mA.
- ★ Do not block ventilation openings in the UPS's housing. Ensure the air vents on the front, side and rear of the UPS are not blocked. Allow at least 25cm of space on each side.

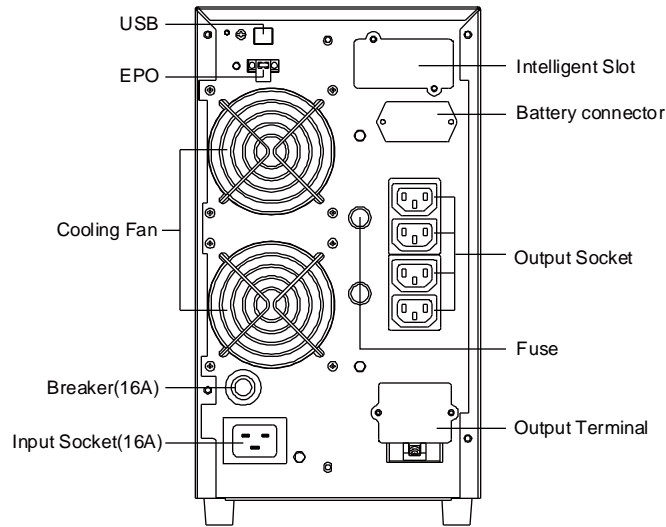

Back View of 3K

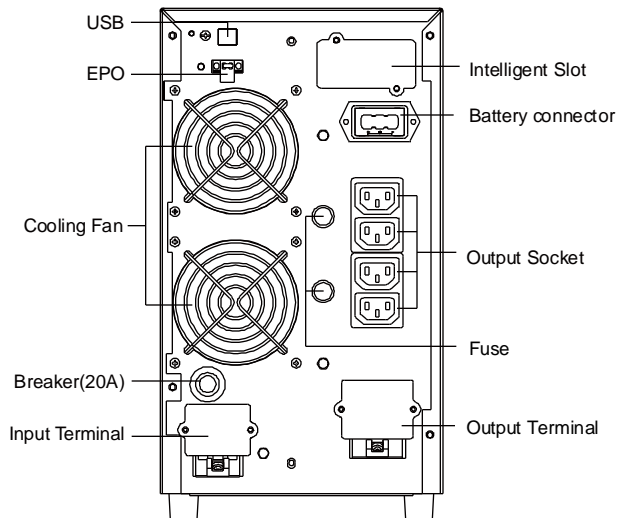

Back View of 3KL

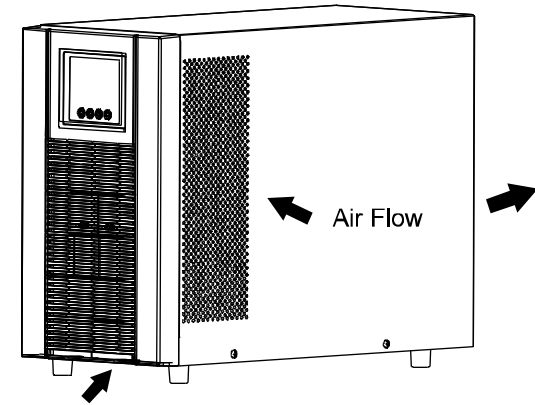

- ★ UPS has provided earthed terminal, in the final installed system configuration, equipotential earth bonding to the external UPS battery cabinets.
- ★ An appropriate disconnect device as short-circuit backup protection should be provided in the building wiring installation. Please see the disconnect device specification in chapter 5.2.
- ★ Equipments powered more than one source.

1.2 Operation

- ★ Do not disconnect the mains cable on the UPS or the building wiring socket (grounded shockproof socket) during operation as this would remove the ground to the UPS and of all connected loads.
- ★ The UPS features its own, internal current source (batteries). You may be electric shock when you touch the UPS output sockets or output terminal block even if the UPS is not connected to the building wiring socket.
- ★ In order to fully disconnect the UPS, first press the OFF button to turn off the UPS, then disconnect the mains lead.
- ★ Ensure that no liquid or other foreign objects can enter the UPS.

- ★ Do not remove the enclosure. This system is to be serviced by qualified service personnel only.
- ★ Remove the protective panel only after disconnecting the terminal connections.
- ★ Use No. 12 AWG (for 2-3K/KL input wire) , 90°C copper wire and 4.4 lb-in Torque force when connecting to terminal block.
- ★ Use No. 12AWG (for 2K/KL output wire) and No. 8AWG (for 3K/KL output wire), 90°C copper wire and 12 lb-in Torque force when connecting to terminal block.

1.3 Maintenance, servicing and faults

- ★ The UPS operates with hazardous voltages. Repairs may be carried out only by qualified maintenance personnel.
- ★ Caution - risk of electric shock. Even after the unit is disconnected from the mains power supply (building wiring socket), components inside the UPS are still connected to the battery which are potentially dangerous.
- ★ Before carrying out any kind of service and/or maintenance, disconnect the batteries. Verify that no current is present and no hazardous voltage exists in the capacitor or BUS capacitor terminals.
- ★ Batteries must be replaced only by qualified personnel.
- ★ Caution - risk of electric shock. The battery circuit is not isolated from the input voltage. Hazardous voltages may occur between the battery terminals and the ground. Verify that no voltage is present before servicing!
- ★ Batteries have a high short-circuit current and pose a risk of shock. Take all precautionary measures specified below and any other measures necessary when working with batteries:
 - remove all jewellery, wristwatches, rings and other metal objects

Appendix: Rear panel

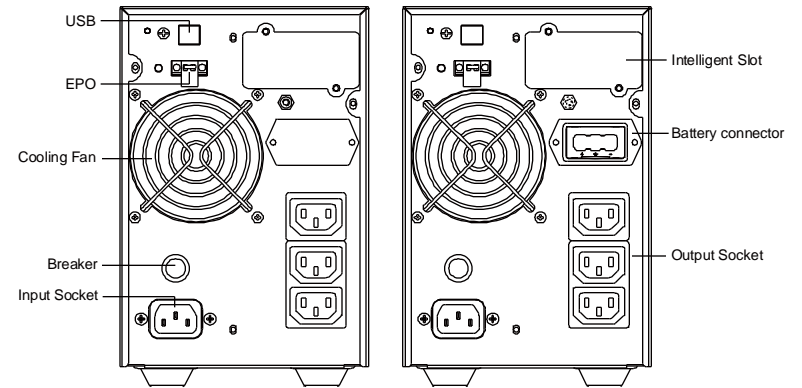

Back View of 1K(L)

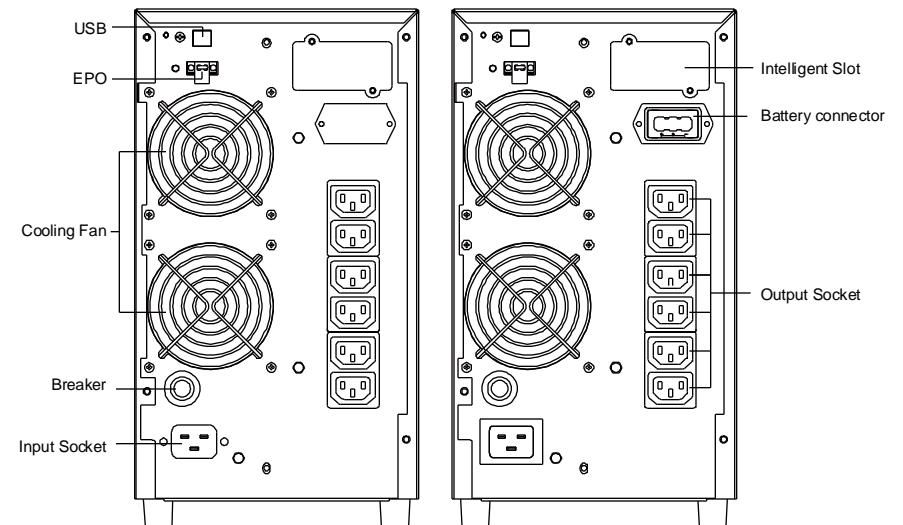

Back View of 2K(L)

12. Software

Free Software Download – WinPower

WinPower is a brand new UPS monitoring software, which provides user-friendly interface to monitor and control your UPS. This unique software provides safely auto shutdown for multi-computer systems while power failure. With this software, users can monitor and control any UPS on the same LAN no matter how far from the UPSs.

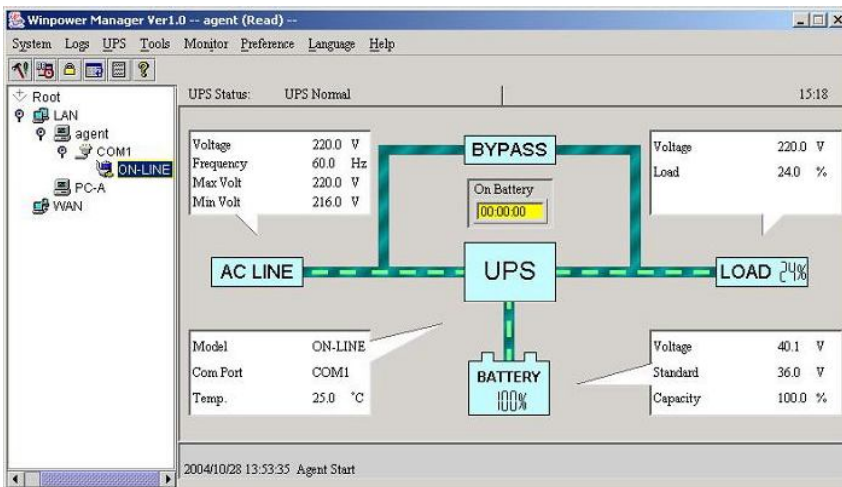

Installation procedure:

1. Go to the website:
<http://www.ups-software-download.com/>
2. Choose the operation system you need and follow the instruction described on the website to download the software.
3. When downloading all required files from the internet, enter the serial No: **511C1-01220-0100-478DF2A** to install the software.

When your computer restarts, the WinPower software will appear as a green plug icon located in the system tray, near the clock.

– use only tools with insulated grips and handles.

- ★ When changing batteries, replace with the same quantity and the same type of batteries.
- ★ Do not attempt to dispose of batteries by burning them. It could cause explosion.
- ★ Do not open or destroy batteries. Effluent electrolyte can cause injury to the skin and eyes. It may be toxic.
- ★ Please replace the fuse only by a fuse of the same type and of the same amperage in order to avoid fire hazards.
- ★ Do not dismantle the UPS, except the qualified maintenance personnel.

1.4 Transport

- ★ Please transport the UPS only in the original packaging (to protect against shock and impact).

1.5 Storage

- ★ The UPS must be stockpiled in the room where it is ventilated and dry.

1.6 Standards

* Safety	
IEC/EN 62040-1	
* EMI	
Conducted Emission.....:IEC/EN 62040-2	Category C1
Radiated Emission.....:IEC/EN 62040-2	Category C1
Harmonic Current.....:IEC/EN 61000-3-2	
Voltage Fluctuation and Flicker.....:IEC/EN 61000-3-3	
*EMS	
ESD.....:IEC/EN 61000-4-2	Level 4
RS.....:IEC/EN 61000-4-3	Level 3
EFT.....:IEC/EN 61000-4-4	Level 4
SURGE.....:IEC/EN 61000-4-5	Level 4
CS.....:IEC/EN 61000-4-6	Level 3
MS.....: IEC/EN 61000-4-8	Level 3
Voltaje Dips.....: IEC/EN 61000-4-11	
Low Frequency Signals.....:IEC/EN 61000-2-2	

11. Communication Port

The communication port is for the monitoring software. A USB port and an intelligent slot are provided.

11.1 USB

The USB port is compliance with USB 1.1 protocol.

11.2 AS400 Interface (Option)

Except for the communication protocol as mentioned above, this series UPS has AS400 card (an optional accessory) for AS400 communication protocol. Please contact your local distributor for details. The following is the pin assignment and description of DB-9 connector in AS400 card.

Pin #	Description	I/O	Pin #	Description	I/O
1	UPS Fail	Output	6	Bypass	Output
2	Summary Alarm	Output	7	Battery Low	Output
3	GND	Input	8	UPS ON	Output
4	Remote Shutdown	Input	9	Line Loss	Output
5	Common	Input			

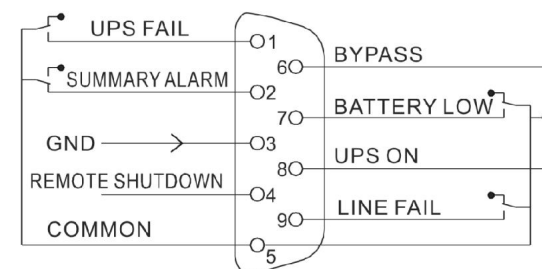

DB-9 Interface of AS400 communication protocol

10.3 Typical backup time (Typical values at 25°C in minutes:)













Model No.	100 % Load	50 % Load
1K	5	14
2K	9	21
3K	5	15

10.4 Dimensions and weights

Model No.	Dimensions W × D × H (mm)	Net Weight (kg)
1K	145 × 400 × 220	13
1KL	145 × 400 × 220	7
2K	192 × 460 × 347	31
2KL	192 × 460 × 347	13
3K	192 × 460 × 347	31
3KL	192 × 460 × 347	13

2. Description of Commonly Used Symbols

Some or all of the following symbols may be used in this manual. It is advisable to familiarize yourself with them and understand their meaning:

Symbol and Explanation			
Symbol	Explanation	Symbol	Explanation
	Alert you to pay special attention		Protective ground
	Caution of high voltage		Alarm silence
	Turn on the UPS		Overload indication
	Turn off the UPS		Battery
	Idle or shut down the UPS		Recycle
	Alternating current source (AC)		Do not dispose with ordinary trash
	Direct current source (DC)		

3. Introduction

This On-Line-Series is an uninterruptible power supply incorporating double-converter technology. It provides perfect protection specifically for Novell, Windows NT and UNIX servers.

The double-converter principle eliminates all mains power disturbances. A rectifier converts the alternating current from the socket outlet to direct current. This direct current charges the batteries and powers the inverter. On the basis of this DC voltage, the inverter generates a sinusoidal AC voltage, which permanently supplies the loads.

Computers and periphery are thus powered entirely by the mains voltage. In the event of power failure, the maintenance-free batteries power the inverter.

This manual covers the UPS listed as follows. Please confirm whether it is the model you intend to purchase by performing a visual inspection of the Model No. on the rear panel of the UPS.

Model No.	Type	Model No.	Type
1K	Standard	1KL	Extended backup time
2K		2KL	
3K		3KL	

“L” Model: Extended backup time

10. Technical Data

10.1 Electrical specifications

INPUT						
Model No.	TAC-HV1K	TAC-HV1KL	TAC-HV2K	TAC-HV2KL	TAC-HV3K	TAC-HV3KL
Phase	Single					
Frequency	(45~55)/(54~66) Hz					
Current(A)	5A	7A	9A	14A	14.5A	18A

OUTPUT			
Model No.	1K(L)	2K(L)	3K(L)
Power rating	1kVA/0.8kW	2kVA/1.6kW	3kVA/2.4kW
Voltage	200/208/220/230/240 × (1 ± 2%) VAC		
Frequency	50/60 ± 0.2Hz (Battery mode)		
Wave form	sinusoidal		

Derating to 90% when the output voltage is adjusted to 208VAC
Derating to 80% when the output voltage is adjusted to 200VAC

BATTERIES			
Model No.	1K	2K	3K
Number and type	3 × 12V 7Ah	8 × 12V 7Ah	8 × 12V 7Ah

10.2 Operating Environment

Ambient Temperature	0 °C to 45 °C
Operating humidity	< 95%
Altitude	< 1000m
Storage temperature	0 °C to 45 °C

9. Maintenance

9.1 Operation

The UPS system contains no user-serviceable parts. If the battery service life (3~5 years at 25°C ambient temperature) has been exceeded, the batteries must be replaced. In this case please contact your dealer.

9.2 Storage

If the batteries are stored in temperate climatic zones, they should be charged every three months for 1~2 hours. You should shorten the charging intervals to two months at locations subject to high temperatures.

9.3 Battery Replace

If the battery service life has been exceeded, the batteries must be replaced.

Battery replacement should be performed only by qualified personnel.

It recommends to shut off the UPS completely before the replacement. If there is a battery breaker then turn it off first. Disconnect the battery cable carefully and make sure no any exposed wires can be touched. Reconnect the new batteries to the UPS by following section 5.8. Then turn on the battery breaker and start the UPS.

If it needs to replace the batteries while the UPS is running, make sure the UPS would not shut down during the replacement. If there is a battery breaker then turn it off first. Disconnect the battery cable carefully and make sure no any exposed wires can be touched. Reconnect the new batteries to the UPS by following section 5.8. Then turn on the battery breaker and press the ON switch to make the UPS do the battery test, check whether the battery information is normal.

4. Panel Description

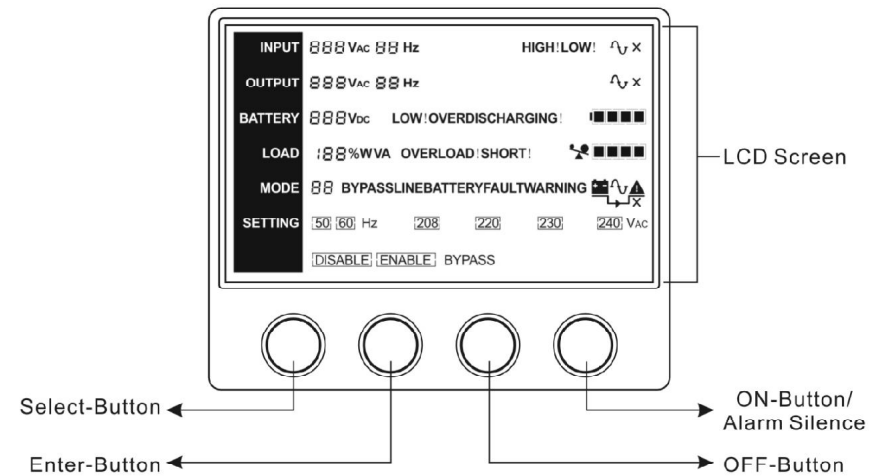

The Display Panel

Switch	Function
ON-Button	Turn on UPS system: By pressing the ON-Button "I" the UPS system is turned on. Deactivate acoustic alarm: By pressing this Button an acoustic alarm can be deactivated.
OFF-Button	When mains power is normal, the UPS system switches to No output or Bypass mode by pressing OFF-Button "⏏", and the inverter is off. At this moment, if Bypass is enabled, then the output sockets are supplied with voltage via the bypass if the mains power is available.
Select-Button	If the UPS system is No output or Bypass mode, the output voltage and frequency and Bypass disable/enable could be selected by pressing Select-Button, and confirmed by pressing Enter-Button.
Enter-Button	If the UPS system is No output or Bypass mode, the output voltage and frequency and Bypass disable/enable could be selected by pressing Select-Button, and confirmed by pressing Enter-Button.

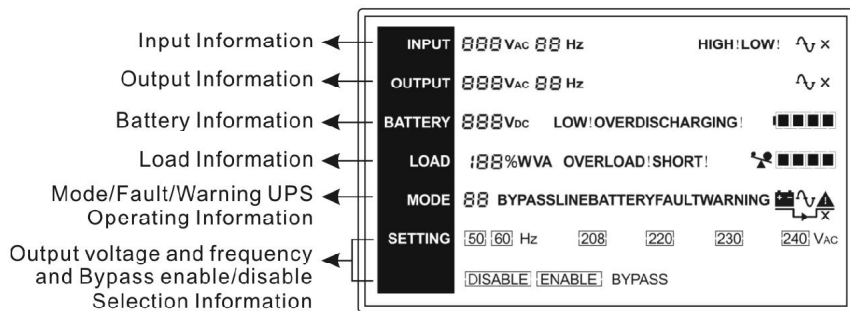





The LCD Display













Please have the following information at hand before calling the After-Sales Service Department:

1. Model number, serial number
2. Date on which the problem occurred
3. LCD display status, Buzzer alarm status
4. Utility power condition, load type and capacity, environment temperature, ventilation condition
5. The information (battery capacity, quantity) of external battery pack if the UPS is "L" model
6. Other information for complete description of the problem

Display	Function
Input Information	
888VAC	Indicates the input Line voltage value, which could be displayed from 0 to 999Vac
88Hz	Indicates the frequency value of input Line voltage, which could be displayed from 0 to 99Hz
HIGH!	Indicates the input Line voltage is higher than the SPEC range, and the UPS would be working in Battery mode
LOW!	Indicates the input Line voltage is lower than the SPEC range, and the UPS would be working in Battery mode
	Indicates the input power state, it would always be displayed
X	Indicates the input power is off only if it is displayed
Output Information	
888VAC ⁽¹⁾	Indicates the UPS output voltage value, which could be displayed from 0 to 999Vac
88Hz	Indicates the frequency value of the UPS output voltage, which could be displayed from 0 to 99Hz

Inverter temperature high	Inside temperature of the UPS is too high	Check the ventilation of the UPS, check the ambient temperature.
Ambient temperature high	The ambient temperature is too high	Check the environment ventilation.
Line voltage high (OVCD action)	Input power voltage is too high	Switching to battery mode automatically, and after the mains is normal, the UPS would Switching to line mode automatically again.
Battery open	Battery pack is not connected correctly	Do the battery test to confirm. Check the battery bank is connected to the UPS. Check the battery breaker is turn on.
Overload	Overload	Check the loads and remove some non-critical loads. Check whether some loads are failed.
Site fail	Phase and neutral conductor at input of UPS system are reversed	Rotate mains power socket by 180° or connect UPS system.
EPO active	EPO function is enabled	Plug into the EPO switch.
Bus fault	UPS internal fault	Notify dealer
Inverter fault	UPS internal fault	Notify dealer
Over temperature fault	Over temperature	Check the ventilation of the UPS, check the ambient temperature and ventilation.
Inverter short	Output short circuit	Remove all the loads. Turn off the UPS. Check whether the output of UPS and loads is short circuit. Make sure the short circuit is removed, and the UPS has no internal faults before turning on again.
Bus short	UPS internal fault	Notify dealer

	Indicates the UPS output state, it would always be displayed
	Indicates the UPS output is shut off only if it is displayed
Load Information	
188%WVA	Indicates the load percent in Watt or VA, only the maximum value of them could be displayed from 0 to 199%
SHORT!	Indicates the load or the UPS output is short and the UPS would shut down
OVERLOAD!	Indicates the load is over the SPEC range
	Indicates the load percent, and every grid represent 25% load.
	Indicates the load is over the SPEC range
Battery Information	
888VDC	Indicates the battery voltage value, which could be displayed from 0 to 999Vdc
	Indicates the battery capacitance percent, and every grid represent 25% capacitance.
DISCHARGING!	Indicates the UPS is working in the battery mode, and the battery is discharged for supplying the load
OVER CHARGING!	Indicates the battery is over charged, and the UPS would be switched to Battery mode
LOW!	Indicates the battery is weak, and the UPS would shut down soon
Mode/Fault/Warning UPS Operating Information	
88	Indicates the operating mode of the UPS, Mode code or Fault code or Warning code could be displayed, and the codes are illuminated in detail in the following chapter

BYPASS 	Indicates the UPS is working in bypass mode, the load is directly supplied by the input power through bypass
	Indicates the UPS is working in no output mode
LINE 	Indicates the UPS is working in line mode
BATTERY 	Indicates the UPS is working in battery mode
FAULT	Indicates the UPS is working in fault mode
WARNING	Indicates some warnings occur which need be attention
	Indicates the UPS is abnormal in which some faults or warnings occur
Output voltage and frequency and Bypass disable/enable selection Information	
 208  220  230  240 VAC	The four value of the output voltage could be selected when the UPS is in No output or Bypass mode, and only one of them could be active in the same time. Derating 10% when the output voltage is adjusted to 208VAC
 50  60 Hz	The two frequency value of the output voltage could be selected when the UPS is in No output or Bypass mode, and only one of them could be active in the same time
 DISABLE  ENABLE BYPASS	Bypass disable or enable could be selected when the UPS is in No output or Bypass mode, and only one of them could be active in the same time

(1) Here would become **UPS, ECO, CVF** instead when the user does operating mode of UPS setting.

“UPS” means the setting of normal inverter mode (Line mode).

“ECO” means the setting of economy mode.

“CVF” means the setting of converter mode.

The detail illustration of the three modes and the operation of the setting would be presented in the following section.

If the UPS system does not operate correctly, please attempt to solve the problem using the table below.

Problem	Possible cause	Remedy
No indication, no warning tone even though system is connected to mains power supply	No input voltage	Check building wiring socket outlet and input cable.
Display Mode code "1" in LCD, even though the power supply is available	Inverter not switched on	Press On-Switch "I".
Display Mode code "3" in LCD, and audible alarm sounding every 1 beep in every 4 seconds	Mains power supply has failed, or Input power and/or frequency are out of tolerance	Switching to battery mode automatically. Check input power source and inform dealer if necessary.
Emergency supply period shorter than nominal value	Batteries not fully charged / batteries defect	Charge the batteries for at least 5 - 8 hours and then check capacity. If the problem still persists, consult your dealer.
Fan fail	Fan abnormal	Check if the fan is running
Battery over voltage	Battery is over charged	Switching to battery mode automatically, and after the battery voltage is normal and the mains is normal, the UPS would Switching to line mode automatically again.
Battery low	Battery voltage is low	When audible alarm sounding every second, battery is almost empty.
Charge fail	The charge is broken	Notify dealer.
DC-DC temperature high	Inside temperature of the UPS is too high	Check the ventilation of the UPS, check the ambient temperature.

8. Trouble Shooting

If the UPS system does not operate correctly, check the operating status on the LCD display.

Normal operating mode	Code
No output mode	0
Bypass mode	1
Line mode	2
Battery mode	3
Battery test mode	4
ECO mode	5
Converter mode	6
Warning	Code
Site fail	09
Fan fail	10
Battery over voltage (over charged)	11
Battery low	12
Charge fail	13
DC-DC temperature high	21
Inverter temperature high	24
Ambient temperature high	25
Line voltage high (OVCD action)	26
Battery open	27
Overload	29
Fault	Code
Bus fault	05
Inverter fault	06
Overload fault	07
Over temperature fault	08
Inverter short	14
Bus short	28

5. Connection and Operation

The system may be installed and wired only by qualified electricians in accordance with applicable safety regulations!

When installing the electrical wiring, please note the nominal amperage of your incoming feeder.

5.1 Inspection:

Inspect the packaging carton and its contents for damage. Please inform the transport agency immediately should you find signs of damage.

Please keep the packaging in a safe place for future use.

Note: Please ensure that the incoming feeder is isolated and secured to prevent it from being switched back on again.

5.2 Connection:

(1) UPS Input Connection

If the UPS is connected via the power cord, please use a proper socket with protection against electric current, and pay attention to the capacity of the socket: over 9A for 1K(L), over 17A for 2K(L), over 26A for 3K(L). If the UPS is connected via wires, it is recommended to select the 2.5mm² wire, and the "GND" terminal should be grounded first by using the green/yellow wire. The wiring is shown as the following.

The UPS System has an input breaker on the cabinet. But we still recommend users to connect an external breaker or protective components to the input terminals. It is recommended to select the NFB(Non-Fuse Breaker) instead of the traditional combination kit including breaker and fuse."

When selecting the NFB, the user can refer to below table for detailed information when installation.

Model No.	UPS INPUT NFB	
	VOLTAGE	CURRENT
1K(L)	300Vac	10A
2K(L)	300Vac	20A
3K(L)	300Vac	32A

(2) UPS Output Connection

The output of the UPS is US-type sockets. Simply plug the load power cord to the output sockets to complete connection. Use one cord for every 10A load.

Model No.	Output Socket (pcs)
1K(L)	3 IEC-type
2K(L)	6 IEC-type
3K(L)	4 IEC-type

The wiring configuration is shown as the following procedure:

- Remove the small cover of the terminal block.
- Use 2.5mm² wires for wiring configuration.
- Upon completion of the wiring configuration, please check whether the wires are securely affixed.
- Put the small cover back to the rear panel.

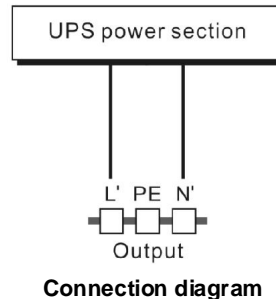

Caution!

Do not connect equipment which would overload the UPS system (e.g. laser printers)

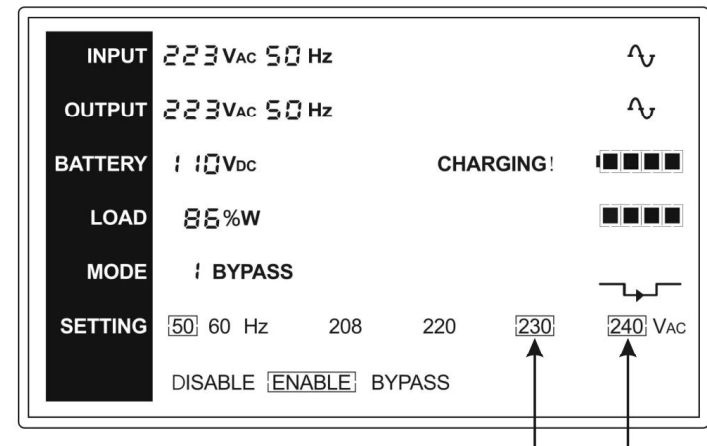

Setp 3: The dot before "230Vac" would turn to flickerless after pressing the "Enter" button.

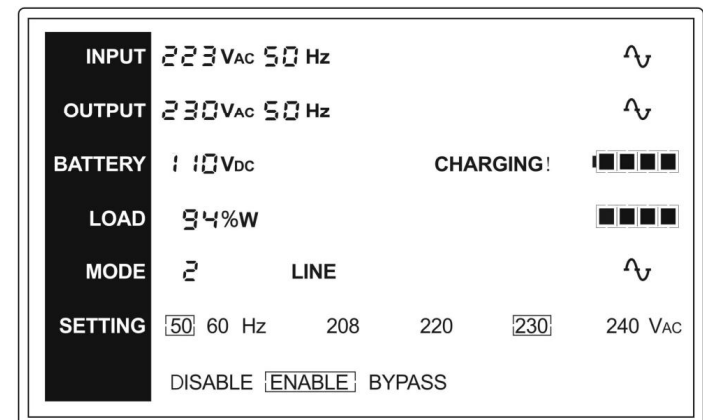

Setp 4: The output voltage would be 230Vac after the UPS is turned on.

- Here is an example for changing the output voltage from 220Vac to 230Vac through the LCD panel.

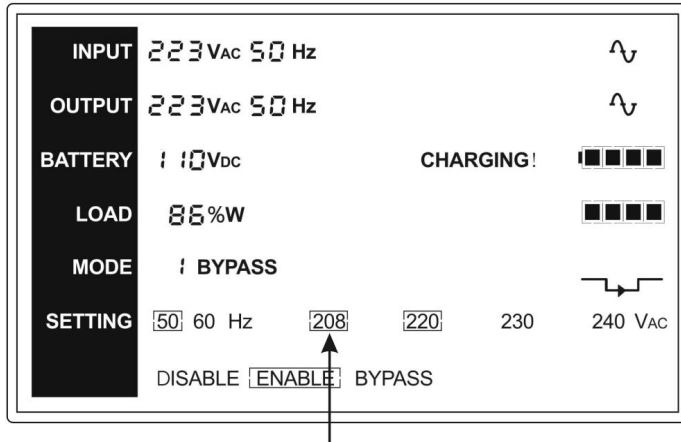

Step 1: One flickering black dot would appear before “208Vac” after pressing the “Select” button.

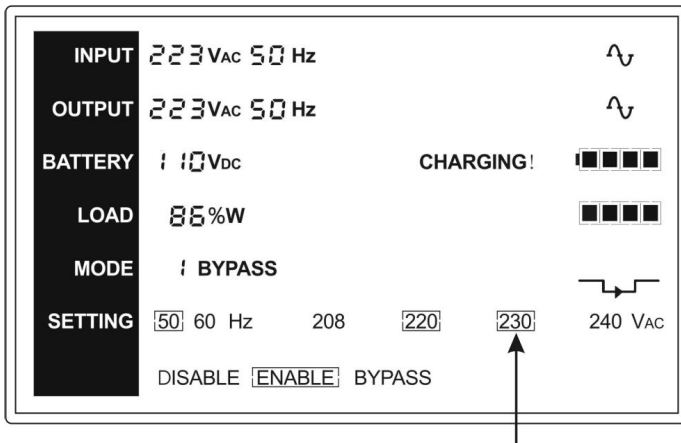

Step 2: The flickering dot would move to “230Vac” after pressing the “Select” button two times again.

(3) EPO Connection:

User can select the polarity of EPO, EPO is Normally Close for the UPS

- **Normally open**

Normally the EPO connector is open on the rear panel. Once the connector is closed with a wire, the UPS would stop the output until the EPO status is disabled.

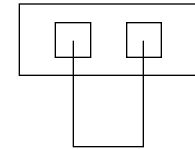
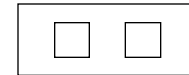

Disable the EPO status

Enable the EPO status

- **Normally close**

Normally the EPO connector is closed with a wire on the rear panel. Once the connector is open, the UPS would stop the output until the EPO status is disabled.

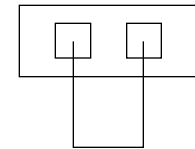
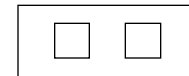

Enable the EPO status

Disable the EPO status

5.3 Battery charge:

Fully charge the batteries of the UPS system by leaving the UPS system connected to the mains for 1-2 hours. You may use the UPS system directly without charging it but the stored energy time may be shorter than the nominal value specified.

5.4 Turn on the UPS:

(1) With utility power connecting:

Press “I” button continuously for more than 1 second to turn on the

UPS, the UPS will get into the inverter mode, the LCD screen will indicate the state of the UPS.

(2) Without utility power connecting:

If UPS is cold start without utility power connecting, user need to push “I” button twice, first pushing “I” button is for UPS to get power, and second pushing “I” button continuously for more than 1 second is for UPS to turn on, the UPS will get into the inverter mode. In fact, the two pushing “I” button is to make further sure user operation for turning on UPS, the LCD screen will indicate the state of the UPS.

Note: The default setting for bypass mode is no output after UPS is connecting utility power and breaker is turned on. This can be configured by monitoring the LCD panel or firmware.

5.5 Test function:

Test the function of the UPS system by pressing the On-Switch “I” for more than 1 second, the UPS would detect whether the battery is connected or the battery is low. And the UPS could also do the test automatically and periodically, the period time could be set by user.

5.6 Turn off the UPS:

(1) In Inverter Mode:

Press “⏻” button continuously for more than 1 second to turn off the UPS, the UPS will get into no output or bypass mode. At this time, the UPS might has output if bypass is enabled. Disconnect the utility power to turn off the output.

(2) In Battery Mode:

Press “⏻” button continuously for more than 1 second to turn off the UPS, the UPS will be turned off completely.

7. Setting by LCD Module

The output voltage and frequency, and bypass state, and ECO mode, and Converter mode could be set directly through LCD module. The output voltage could be set to 208V, 220V, 230V and 240V. The output frequency could be set to 50Hz and 60Hz. The operating mode of UPS could be set between the Line mode, ECO mode and Converter mode. The bypass state could be set to enable and disable. But all the settings could only be done when the UPS is in bypass or no output mode.

In bypass or no output mode, pressing the “Select” button on the LCD panel for more than one second, a flickering black dot would be shown before “208V” on the screen. And if pressing the “Select” button continuously again, the flickering black dot would move to “220V”, next to “230V”, “240V”, “50Hz”, “60Hz”, “Bypass Disable”, “Bypass Enable”, “UPS”, “ECO”, “CVF” in turn. (Here “UPS” means the normal inverter mode, and “UPS”, “ECO”, and “CVF” would be presented circularly at the position of output voltage) And if pressing the “Enter” button for more than one second at this time, the flickering black dot would turn to flickerless and the output voltage or frequency or bypass state or mode state setting would be modified to the selected value. And if no any pressing on the “Select” or “Enter” button lasting for more than 30 seconds, the flickering black dot would disappear.

The only one voltage value could be selected in “208V”, “220V”, “230V”, “240V” at any time. The only one frequency value could be selected in “50Hz”, “60Hz” at any time. And the output voltage and frequency would be changed to the corresponding value after the right values are selected on the LCD panel and the UPS is turn on by pressing the “ON” Button. The UPS would turn to bypass mode in several seconds after “Bypass Enable” is selected, and turn to no output mode in several seconds after “Bypass Disable” is selected. The mode change would be active only after the UPS is turned on.

- 2) It is attention that the transfer time of UPS output from ECO mode to battery mode is less than 10ms. But it is still too long for some sensitive load.

6.7 Converter mode

In converter mode, on LCD display, the mode code is "6".

The UPS would free run with fixed output frequency (50Hz or 60Hz) in converter mode. Once the mains is loss or abnormal, the UPS would transfer to battery mode and the load is supplied continuously by the battery.

- 1) It could be enabled through the LCD setting or the software (Winpower, etc.).
- 2) The load should be derating to 60% in converter mode.

6.8 Abnormal mode

In abnormal mode such as Bus fault etc., the corresponding fault code would be shown to indicate the operating mode of the UPS. And some warning words could also be shown, for example "short!" would be shown when the load or the UPS output is short and the UPS is in inverter fault mode.

5.7 Audible alarm mute function:

If the alarm is too annoying in battery mode, you may press "I" button continuously for more than 1 second to clear it. Moreover, the alarm will be enabled when the battery is low to remind you to shutdown the load soon.

If the alarm is too annoying in bypass mode, you may press "U" button continuously for more than 1 second to clear it. The action doesn't affect the warning and fault alarm.

5.8 Operation procedure of external battery for long backup time model ("L" model)

- (1) Use the battery pack with voltage: 36VDC for 1KL (3 pcs of 12V batteries), 96VDC for 2KL/ 3KL (8 pcs of 12V batteries). Connection of batteries more than or less than required will cause abnormality or permanent damage.
- (2) One hard wiring type battery terminal on the rear panel is used for connecting the battery pack.
- (3) The battery connection procedure is very important. Any incompliance may result in the risk of electric shock. Therefore, the following steps must be strictly complied with.
- (4) Make sure the mains input is cut off, if there is a battery breaker then turn it off first.
- (5) Remove the small cover of terminal block, prepare the battery cable which should be able to carry the current of >30A for 1KVA, >22A for 2KVA, >33A for 3KVA, the cross section area should be great than 4 mm² for all model. And battery wire color is recommended as following:

+	GND	-
Red wire	Green/Yellow wire	Black wire

- (6) The red wire is connected to the "+" terminal of the battery. The

black wire is connected to the "-" terminal of the battery. (Note: the green/yellow wire is grounded for protection purpose.)

- (7) Make sure the wires are fasten, install the terminal block cover on the rear panel of the UPS.
- (8) Connect the UPS to the load. Then, turn on the mains switch or connect the power cord of the UPS to utility power supply, the battery would start to be charged.

The Caution!
A DC breaker must be connected between the UPS and external battery.

The Caution!
The output sockets of the UPS system may still be electrically live even if the power supply system has been disconnected or the Bypass switch is on "OFF" position.

Model No.	DC breaker	
	VOLTAGE	CURRENT
1KL	48Vac	50A
2KL	125Vdc	40A
3KL	125Vdc	60A

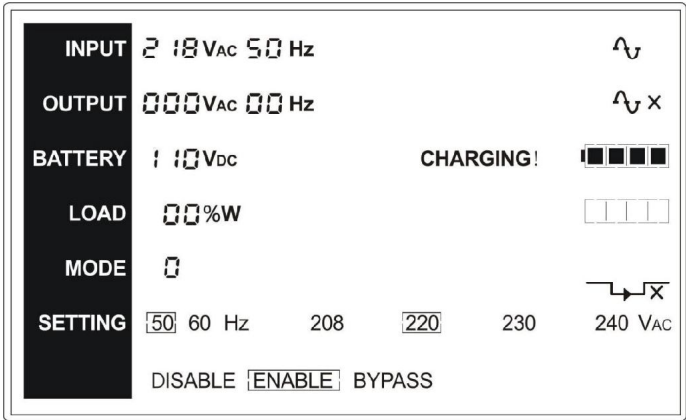

■ The No output mode

6.5 EPO (Emergency Power Off)

It is also called RPO (Remote Power Off). On LCD display, the mode code is "0", the word of "EPO" are presented in the position of output voltage. It is a special status in which the UPS would shut the output off and alarm. The UPS could not be turned off by pressing "OFF" button on the panel, only after releasing EPO status by Plugging into the EPO switch.

6.6 ECO mode (Economy mode)

It is also called high efficiency mode. In ECO mode, on LCD display, the mode code is "5". After the UPS is turned on, the power used by the load is supplied from the utility power via internal filter while the utility power is in normal range, so the high efficiency could be gained in the ECO mode. Once the mains is loss or abnormal, the UPS would transfer to battery mode and the load is supplied continuously by the battery.

- 1) It could be enabled through the LCD setting or the software (Winpower, etc.).

battery mode code of the UPS is “3”, and the battery test mode code is “4”.

6.3 Bypass mode

The LCD display in bypass mode is shown in the following diagram. The information about the utility power, the battery, the UPS output and the load could be displayed. The UPS will beep once every 2 minutes in bypass mode. The word of “BYPASS” indicates the bypass of the UPS is working. The bypass mode code of the UPS is “1”.

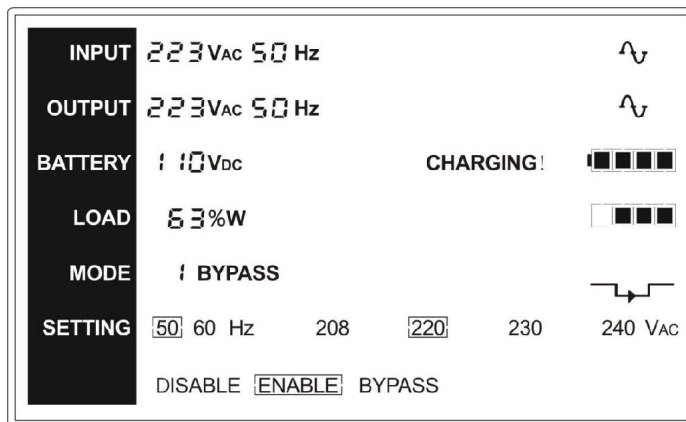

■ The Bypass mode

The UPS does not have the backup function when it is in bypass mode. The power used by the load is supplied from the utility power via internal filter.

6.4 NO output mode

The LCD display in No output mode is shown in the following diagram. The information about the utility power, the battery, the UPS output and the load could be displayed. The “0” code indicates the UPS is working in the No output mode.

6. Operating Mode for All Models

The different codes could be displayed on the LCD screen corresponding to their own operating modes, and they are illustrated as the following table. At any time, only one normal operating mode or fault mode is presented. But the warning, even several warnings could appear in a certain normal operating mode at one time. And the normal operating mode code and the warning code would be shown circularly. Once one fault is come forth, then all previous warnings would not be shown again but only the fault code is presented.

Normal operating mode	Code
No output mode	0
Bypass mode	1
Line mode	2
Battery mode	3
Battery test mode	4
ECO mode	5
Converter mode	6

6.1 Line mode

The LCD display in Line mode is shown in the following diagram. The information about the utility power, the battery, the UPS output and the load could be displayed. The word of “LINE” indicates the inverter of the UPS is working. The operating mode code of the UPS is “2”.

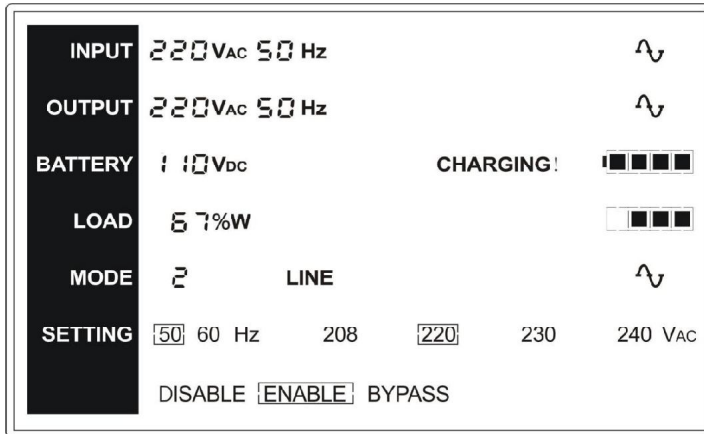

■ The Line mode

If output overloaded, the load percent is shown and alarm will keep twice every second. You should get rid of some unnecessary loads one by one to decrease the loads connected to the UPS less than 90% of its nominal power capacity.

Note: Please follow the following steps to connect the generator:

- Activate the generator and wait until the operation is stable before supplying power of the generator to the UPS (be sure that the UPS is in idle mode). Then turn on the UPS according to the start-up procedure. After the UPS is turned on, then the loads can be connected to the UPS one by one.
- The power capacity of the AC generator should be at least twice of the UPS capacity.

6.2 Battery mode

The LCD display in battery mode is shown in the following diagram. The information about the utility power, the battery, the UPS output

and the load could be displayed. The block of “BATTERY” indicates the inverter of the UPS is working.

- 1) When the UPS is running in battery mode, the buzzer beeps once every 4 seconds. If the “ON” button on the front panel is pressed for more than 1 second again, the buzzer will stop beeping (in silence mode). Press the “ON” button once again for more than 1 second to resume the alarm function.
- 2) If the UPS is working in battery mode for the input line voltage is higher than the SPEC range, the alarm symbol - “High!” will be shown; if the UPS is working in battery mode for the input line voltage is lower than the SPEC range, the alarm symbol - “Low!” will be shown; if the input line voltage is lost, both “High!” and “Low!” would not be shown but the input voltage and frequency are shown as zero.

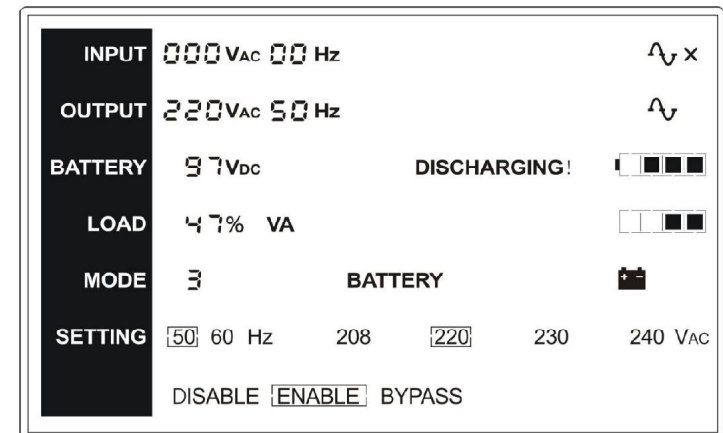

■ The Battery mode

The display of battery test mode is same as battery mode, but “High!” and “Low!” would not be shown unless the input line voltage is higher or lower than the SPEC range during the time of battery test. The