



## Contents

|  |    |
|--|----|
| ◆ Installation attentions .....                    | 3  |
| ◆ Attentions .....                                 | 3  |
| 1. Summary .....                                   | 4  |
| 2. Specs.....                                      | 4  |
| 3. Installation instructions .....                 | 5  |
| 4. Wires connection .....                          | 6  |
| 5. Function setting.....                           | 7  |
| 5.1 Initialization .....                           | 7  |
| 5.2 Change Password .....                          | 8  |
| 5.3 Authorization.....                             | 8  |
| 5.4 Set up monitor central number.....             | 8  |
| 5.5 Single Tracking .....                          | 9  |
| 5.6 Continuous Tracking Automatically.....         | 9  |
| 5.7 Cell ID Tracking .....                         | 9  |
| 5.8 Modes switch between “track” & “monitor” ..... | 9  |
| 5.9 Data logging .....                             | 10 |
| 5.10 Alarms .....                                  | 10 |
| 5.11 Low battery alarm .....                       | 10 |
| 5.12 Power off alarm.....                          | 10 |
| 5.13 Geo-fence alarm.....                          | 11 |
| 5.14 Movement alarm .....                          | 11 |
| 5.15 Overspeed alarm.....                          | 12 |
| 5.16 ACC working alarm .....                       | 12 |
| 5.17 Vibration alarm .....                         | 12 |
| 5.18 Set all alarm mode.....                       | 13 |
| 5.19 Cut off the Oil and Power System .....        | 13 |
| 5.20 Resume the Oil and Power System.....          | 13 |
| 5.21 Check the Vehicle State .....                 | 13 |
| 5.22 Device Resetting .....                        | 14 |
| 5.23 IMEI Checking.....                            | 14 |
| 5.24 Time Setting .....                            | 14 |
| 5.25 GPRS Setting .....                            | 14 |
| 5.25.1 Set APN.....                                | 15 |
| 5.25.4 Set IP and Port.....                        | 15 |
| 6 .Cautions .....                                  | 15 |
| 7 . Faults & the Solutions.....                    | 16 |

## ◆ Installation attentions

**NOTE: device front side towards the sky.**

When install in car, if the windscreen glued by metal thermal insulation layer or heating layer, it will reduce the GPS receive signal and lead to GPS work disorder.

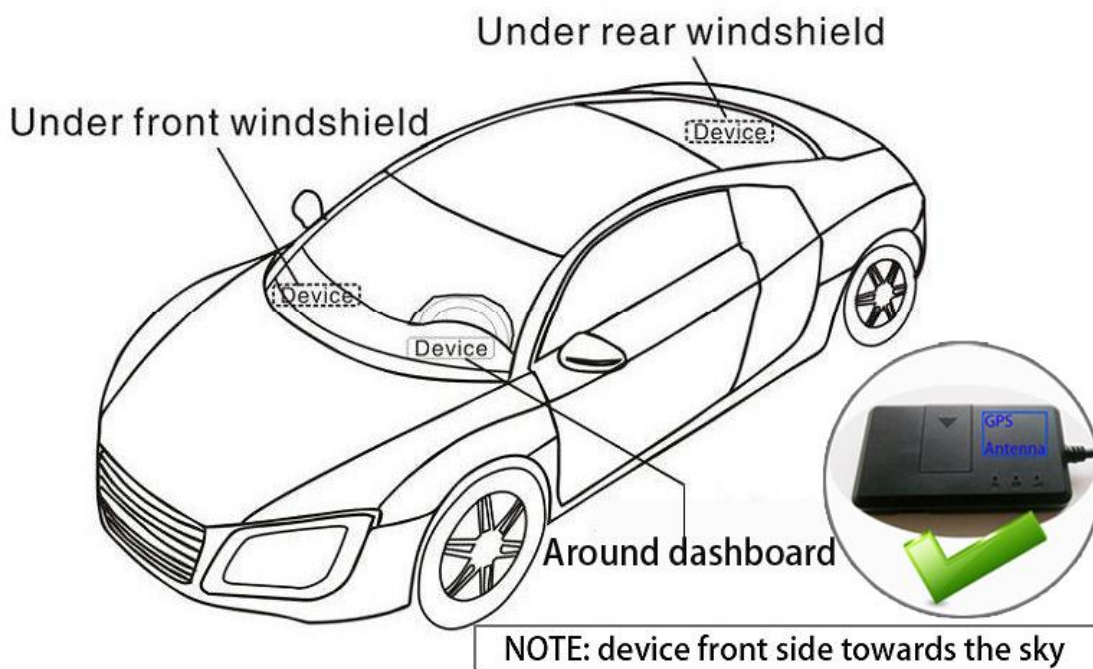

## ◆ Attentions

### ◆ Device light

- 1) No yellow light: failed to read SIM card, need reinstall SIM card.
- 2) Blue light flash: no GPS signal, make sure device started outside.
- 3) Three lights off: lights entered sleep mode, make a call can wake up.

### ◆ Device failed located

- 1) Failed located: message replied with all 0, make sure device started outside not in room.
- 2) Can't reach the call: make sure SIM card has balance and installed properly.

### ◆Device can't track on platform

- 1) Check three lights are stable lighting on. Make sure device can communicate by sending SMS and make a call.
- 2) Check the Vehicle State

Send SMS command “**check+password**” to the tracker device to check the IP port etc info.

## 1.Summary

Working Based on existing GSM/GPRS network and GPS satellites, this product can locate and monitor any remote targets by SMS or GPRS.

**NOTE: Please turn on small switch inside SIM card hole after install SIM card**

## 2.Specs.

| Content           | Specs.  |
|-------------------|---|
| Dim.              | 84 mm x47.5 mm x 15 mm                              |
| Weight            | 50g   |
| Network           | GSM/GPRS/GPS  |
| Band              | 850/900/1800/1900 Mhz                               |
| GPS chip          | UBLOX 7020  |
| GSM module        | MT6260A   |
| GPS sensitivity   | -159dBm   |
| GPS accuracy      | 5m  |
| Time To First Fix | Cold status 45s<br>Warm status 35s<br>Hot status 1s |
| Work voltage      | 9V-36V  |
| Storage Temp.     | -40 °C to +85 °C                                    |
| Operation Temp.   | -20 °C to +45 °C                                    |
| Humidity          | 5%--95%   |

### 3. Installation instructions

#### 3.1 Preparation

4.1.1 Open the package to check the device model number is correct, be with full accessories, or else please contact your supplier;

4.1.2 Choose SIM card, need insert a GSM SIM card into the device, please refer to the suggestion of your supplier for SIM card choice.

Notice:

**Please insert SIM card before turning the device power switch to on;**

The SIM card need open the GPRS function;Please make sure SIM card with full balance.

#### 3.2 Installation

The device is hidden type installation, we suggest the device installing by professional institution. Please pay attention to the following points:

3.2.1 To avoid the thieves destruction, the device installation place should be as far as hidden.

3.2.2 Avoid putting the device with reversing radar, car burglar alarm and any other vehicle communication devices;

3.2.3 Can fix the device by ribbon or wide sponge powerful two-side glue stick;

3.2.4 The device has built-in GSM and GPS antenna, make sure the receive side upward and there is no metal shielding.

3.2.5 Recommended installation place: ①The hidden place in the board below the front windscreen; ② The hidden place around former dashboard (nonmetal

material for skin); ③The hidden place in the board below the back windscreen.

Notice:

If the windscreen glued by metal thermal insulation layer or heating layer, it will reduce the GPS receive signal and lead to GPS work disorder, then please change the installation place.

### 3.3 Device light description

| Light        | Signal     |
|--------------|------------|
| Red light    | Power      |
| Yellow light | GSM signal |
| Blue         | GPS signal |

## 4. Wires connection

1. Red wire connects to vehicle power anode
2. Black wire connects to vehicle power cathode
3. Yellow wire connects to oil or circuit control wires
4. Green wire connects to ACC wire

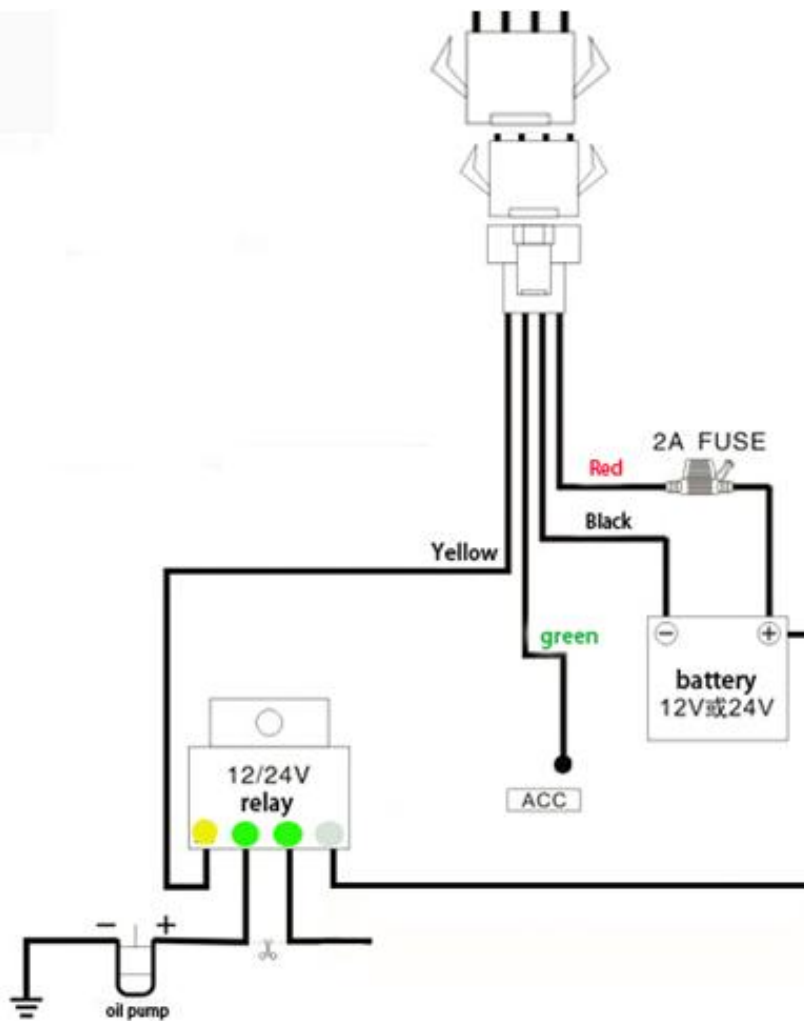

## 5. Function setting

### 5.1 Initialization

Send SMS “**begin+password**” to the unit, it will reply “BEGIN,CONFIG OK ” and initialize all the settings to default factory settings. (default password: 123456)

For example: send SMS “begin123456”, it will reply “BEGIN,CONFIG OK ”.

**The “+” in the command, please don’t type “+”, space means press the space keyboard on your cell phone.**

## 5.2 Change Password

5.2.1 Send SMS “**password+old password+space+new password**” to the unit to change the password.

For example: send SMS “password123456 888888” to the unit. If succeeded, “PASSWORD,CONFIG OK” will reply to your cell phone from the device tracker.

5.2.2 Make sure the new password is in 6 digits, or else the tracker cannot recognize the password.

## 5.3 Authorization

There are 5 numbers to be allowed to authorize in the tracker at most.

5.3.1 Authorization: Send SMS“**admin+password+space+cell phone number**” to set up an authorized number, the other central number should be set by the first authorized number, if the number is successfully authorized, the unit will reply” ADMIN,CONFIG OK” by SMS.

5.3.2 Delete authorization: Send SMS“**noadmin+password+space+authorized number**” to delete the authorized number.

## 5.4 Set up monitor central number

**All alarms will be received by central number.**

5.4.1 Setup: send command “**centernum+password+space+number**” to tracker, it will reply “centernum ok”. After setup monitor center number, the messages of auto track by SMS will be set to this center number, if all alarms need to be sent to this number too, then this center number must be setup as



authorized number.

5.4.2 Cancel: Send “**centernum+password**” to tracker, it will reply “CENTERNUM,CONFIG OK”.

## 5.5 Single Tracking

Make a missed call to device number or Send SMS “**smslink123456**” to device number, it will reply a real time tracking message include Long & Lat info.

## 5.6 Continuous Tracking Automatically

5.6.1 Send SMS command “**ITV+password+space+moving time interval+space+static time interval**” to the tracker device.

5.6.2 For example: send SMS “ITV123456 10 500” it will report data to server at 10s time interval when vehicle is moving; 500s time interval when vehicle is static.

## 5.7 Cell ID Tracking

5.7.1 You must set up the APN of your local GSM network for the SIM card in tracker first before using this function, if there is user name and password for GPRS login, Please refer to following to configure the APN, user name and password for GPRS login.

5.7.2 After configure the APN, send SMS “**cell+password**” to device, it will reply cell ID info. (This function need platform support )

## 5.8 Modes switch between “track” & “monitor”

5.8.1 The default mode is “track” (track mode).

5.8.2 Send SMS command “**monitor+password**” to tracker device of vehicle

terminal, it will reply "MONITOR,CONFIG OK" and switch to “monitor” mode. In this mode, the user can dial up the tracker device to monitor the voice.

5.8.3 Send SMS command "**tracker+password**" to tracker device of vehicle terminal, It will return "TRACKER,CONFIG OK" and restore to “track” mode.

## 5.9 Data logging

This function must insert TF card.

Auto logging: When the tracker device lost GSM signals or fall offline from GPRS, tracker will log the tracking position and alerts automatically in the SD card on the basis of the pre-set condition, when GSM signals get back, all the event alerts will be auto-sent to the authorized numbers or monitoring platform (server), but the logged tracking data should be loaded to the monitoring platform via SMS command.

## 5.10 Alarms

Note: All Alarms will be sent to Central Number

### 5.11 Low battery alarm

5.11.1 Send SMS “**lowbat+password+space+1**” to activate the function, it will send SMS“low battery+latitude/longitude” to central number when voltage of battery is below about 3.6V.

5.11.2 This function disactivates as default, send SMS “**lowbat+password+space+0**” to deactivate.

### 5.12 Power off alarm

5.12.1 Send “**extpower+password+space+1**” to activate, it will send SMS

“power alarm+latitude/longitude” to central number when external power is cut off.

5.12.2 This function disactivates as default. Cancel: Send SMS “**extpower+password+space+0**” to deactivate it.

### 5.13 Geo-fence alarm

Set up a geo-fence for the tracker device to restrict its movements within a district. The unit will send SMS to the central number when it detects alarm.

**Remark: 0 represents close alarm; 10 represents out fence alarm; 01 represents enter fence alarm; 11 represents out and enter fence alarm.**

5.13.1 Set Up:

Send SMS“**stockade+password+space+semi-diameter+space+alarm type**” to unit to set the restricted district. In case of breach, it will send SMS “stockade!+geo-info” to the central number.

For example: send SMS “stockade000000 500 1” stands for based on device current coordinates as center, 500 is semi-diameter, set 1 as out fence alarm type.

5.13.2 Cancel: Send SMS “**nostockade+password**” to deactivate this function.

### 5.14 Movement alarm

Device will send movement alarm once vehicle moved 100 meters. The function is default activate if detected vehicle ACC ON. When vehicle ACC OFF stands for closing movement alarm.

(Note: this function must connect ACC wire ).

## 5.15 Overspeed alarm

6.8.7.1 Set up: Send SMS “**speed+password+space+80**” to the unit(suppose the speed is 80km/h),and it will reply “speed OK!”. When the target moves exceeding 80km/h.the unit will send SMS “speed+Geo-info” to the central number.

5.15.1 Cancel: Send SMS “**speed+password+space+0**” to deactivate the overspeed alarm.

Remark: It is recommended that the speed alarm is set at not less than 30km/h.For below that rate; it may cause the excursion of the GPS signal influenced by clouds etc.

## 5.16 ACC working alarm

5.16.1 This function is disabled as default. To active this functions, send "**ACC+password+Space+1**" to tracker, it will reply "ACC,CONFIG OK". And tracker will send "ACC on+latitude & longitude" to central number when detect ignition action, that means the vehicle has been started.

5.16.2 Send "**ACC+password+Space+0**" to disabled this function, tracker will reply "ACC,CONFIG OK".

## 5.17 Vibration alarm

Send SMS “**vibrate+password+space+0**” to deactivate this function.

Send SMS “**vibrate+password+space+1-15**” to set up vibrate level from 1 to 15 (1 is strongest level, 15 is lowest level)

### 5.18 Set all alarm mode

Send SMS "**KC +password+space+0**" to tracker to close the function.

Send SMS "**KC +password+space+1**" to tracker to choose alarm by SMS.

Send SMS "**KC +password+space+2**" to tracker to choose alarm by calling.

### 5.19 Cut off the Oil and Power System

Send SMS command "**DY+password**" to the tracker device, it will reply "DY CONFIG OK" to your cell phone from the tracker device, and stop your car oil pump or elec as well.

### 5.20 Resume the Oil and Power System

Send SMS command "**TY+password**" to the unit, It will reply "TY,CONFIG OK" and resume your car oil pump or elec as well.

### 5.21 Check the Vehicle State

Send SMS command "**check+password**" to the tracker device in the vehicle, it will reply following SMS:

```
CHECK,imei:13579024681122
0,apn:,IP:220.231.161.156:696
9,Cnum:,Gps:1,Gsm:60,itv:30,T
Z:0,OS:0,GF:0,0,0,Door:0
```

Cnum: center number;

GSM:60: means GPS signal value

GPS:1 : 1 means GPS located, 0 means not located;

itv:30: time interval is 30 seconds;

TZ:8: time zone is GMT 0;

GF:500,1,1: Geo-fence function, 500meters.

OS: 0 means deactivate, 1 means activate

door:1: means door alarm function open.

## 5.22 Device Resetting

### SMS Reset

Send SMS “**reset+password**” to tracker device to reset the GSM module and GPS module of the tracker device, it will reply “reset ok”.

## 5.23 IMEI Checking

5.23.1 Send SMS command "**getimei+password**" to the unit. E.g. Send SMS command "getimei123456" to the tracker device, an IMEI number in 15 digits will reply to your cell phone.

5.23.2 Send SMS command "**setimei+password+space+15 digits IMEI number**" to the unit.

E.g. Send SMS command "setimei123456 123456789012345" to the tracker device, it will reply SMS “SETIMEI,CONFIG OK”.

## 5.24 Time Setting

5.24.1 Send SMS command “**timezone123456+space+time**” to the tracker unit, If succeed, It will reply “time OK”

5.24.2 For example: Send SMS “timezone123456 8”, 8 is Chinese time zone, If your country time zone is minus, send SMS “time zone123456 -8”.

## 5.25 GPRS Setting

User must send SMS via cell phone to set up APN, IP and port before starting

tracking by GPRS on tracking system.

### 5.25.1 Set APN

6.22.1.1 APN standards for Access Point Name and differs from country to country. For more information about your local APN, please inquire with your local GPRS network operator.

5.25.2 Send SMS “**APN+password+space+local APN+space+APN name+space+APN password**” via a cell phone and if succeeded, the tracker will return the message “APN OK”.

5.25.3 E.g. Send SMS command “APN123456 CMNET”. If succeeded, it will reply SMS “APN OK”

Notes: CMNET is the APN of one of china GPRS Network Operator (China mobile), it has no APN name and Password.

### 5.25.4 Set IP and Port

Send SMS: “**adminip+password+space+IP Address+space+port number**”, If succeeded, it will reply “ADMINIP,CONFIG OK”. E.g. Send SMS: “adminip123456 116.205.4.114 8169” to the tracker device, (116.205.4.114 is IP, 8169 is port).

## 6 .Cautions

**Please comply with the instructions to extend the unit life:**

1. Keep the unit dry. Any liquid, i.e. rain, moisture, may destroy or damage the inside circuitry.
2. Don't use & store the unit in dusty places.

3. Don't put the unit in overheated or overcooled places.
4. Handle carefully. Don't vibrate or shake it violently.
5. Clear the unit with a piece of dry cloth. Don't clean in chemicals, detergent.
6. Don't paint the unit, this may cause some foreign materials left in between the parts.
7. Don't disassemble or refit the unit.
8. Please read the user manual carefully before installation and operation, learn something more about the voltage range. Otherwise, it won't work properly or destroy the product.

## **7 . Faults & the Solutions**

| Faults                              | Solution   |
|-------------------------------------|--|
| Startup Fail                        | Please check SIM card hole small switch turn on or not |
| Location report in digits of zeros. | Make sure device work outside not in room              |
| Monitor Fail                        | Check if the authorized number is setup                |
| Can't show online Platform          | Check if IP and APN SMS are setup                      |