

# Instruction manual

**ESPAÑOL: PÁGINA 19**  
**FRANÇAISE : PAGE 37**

## Double Insulated Profile Sanders



MODEL 444



MODEL 444VS

### IMPORTANT

Please make certain that the person who is to use this equipment carefully reads and understands these instructions before starting operations.

The Model and Serial No. plate is located on the main housing of the tool. Record these numbers in the spaces below and retain for future reference.

Model No. \_\_\_\_\_

Type \_\_\_\_\_

Serial No. \_\_\_\_\_

To learn more about Porter-Cable  
visit our website at:

<http://www.porter-cable.com>

**PORTER + CABLE**  
PROFESSIONAL POWER TOOLS

## TABLE OF CONTENTS

IMPORTANT SAFETY INSTRUCTIONS .....	2
SAFETY GUIDELINES .....	3
GENERAL SAFETY RULES .....	4
ADDITIONAL SPECIFIC SAFETY RULES .....	6
ADDITIONAL SAFETY RULES FOR PAINT REMOVAL .....	8
CARTON CONTENTS .....	10
FUNCTIONAL DESCRIPTION .....	10
ASSEMBLY .....	10
OPERATION .....	10
TROUBLESHOOTING .....	17
MAINTENANCE .....	17
SERVICE .....	18
ACCESSORIES .....	18
WARRANTY .....	18
ESPAÑOL .....	19
FRANÇAISE .....	37
SERVICE CENTER LOCATIONS .....	back cover

## IMPORTANT SAFETY INSTRUCTIONS

**⚠ WARNING** Read and understand all warnings and operating instructions before using any tool or equipment. When using tools or equipment, basic safety precautions should always be followed to reduce the risk of personal injury. Improper operation, maintenance or modification of tools or equipment could result in serious injury and property damage. There are certain applications for which tools and equipment are designed. Porter-Cable strongly recommends that this product NOT be modified and/or used for any application other than for which it was designed.

If you have any questions relative to its application DO NOT use the product until you have written Porter-Cable and we have advised you.

Online contact form at [www.porter-cable.com](http://www.porter-cable.com)

Postal Mail: Technical Service Manager  
Porter-Cable Corporation  
4825 Highway 45 North  
Jackson, TN 38305

Information regarding the safe and proper operation of this tool is available from the following sources:

Power Tool Institute

1300 Sumner Avenue, Cleveland, OH 44115-2851

[www.powertoolinstitute.org](http://www.powertoolinstitute.org)

National Safety Council

1121 Spring Lake Drive, Itasca, IL 60143-3201

American National Standards Institute, 25 West 43rd Street, 4 floor, New York, NY 10036 [www.ansi.org](http://www.ansi.org) ANSI 01.1 Safety Requirements for Woodworking Machines, and the U.S. Department of Labor regulations [www.osha.gov](http://www.osha.gov)

**SAVE THESE INSTRUCTIONS!**

## SAFETY GUIDELINES - DEFINITIONS

It is important for you to read and understand this manual. The information it contains relates to protecting YOUR SAFETY and PREVENTING PROBLEMS. The symbols below are used to help you recognize this information.



### **▲ DANGER**

indicates an imminently hazardous situation which, if not avoided, will result in death or serious injury.

### **▲ WARNING**

indicates a potentially hazardous situation which, if not avoided, could result in death or serious injury.

### **▲ CAUTION**

indicates a potentially hazardous situation which, if not avoided, may result in minor or moderate injury.

### **CAUTION**

used without the safety alert symbol indicates potentially hazardous situation which, if not avoided, may result in property damage.

## CALIFORNIA PROPOSITION 65

### **▲ WARNING**

Some dust created by power sanding, sawing, grinding, drilling, and other construction activities contains chemicals known (to the State of California) to cause cancer, birth defects or other reproductive harm. Some examples of these chemicals are:

- lead from lead-based paints
- crystalline silica from bricks and cement and other masonry products
- arsenic and chromium from chemically-treated lumber

Your risk from these exposures varies, depending on how often you do this type of work. To reduce your exposure to these chemicals: work in a well ventilated area, and work with approved safety equipment, always wear NIOSH/OSHA approved, properly fitting face mask or respirator when using such tools.

# GENERAL SAFETY RULES

## **⚠️ WARNING**

Read all instructions. Failure to follow all instructions listed below may result in electric shock, fire and/or serious injury. The term "power tool" in all of the warnings listed below refers to your mains-operated (corded) power tool or battery-operated (cordless) power tool.



SAVE THESE INSTRUCTIONS

## 1) Work area safety

- a) **Keep work area clean and well lit.** Cluttered or dark areas invite accidents.
- b) **Do not operate power tools in explosive atmospheres, such as in the presence of flammable liquids, gases or dust.** Power tools create sparks which may ignite the dust or fumes.
- c) **Keep children and bystanders away while operating a power tool.** Distractions can cause you to lose control.

## 2) Electrical safety

- a) **Power tool plugs must match the outlet. Never modify the plug in any way. Do not use any adapter plugs with earthed (grounded) power tools.** Unmodified plugs and matching outlets will reduce risk of electric shock.
- b) **Avoid body contact with earthed or grounded surfaces such as pipes, radiators, ranges and refrigerators.** There is an increased risk of electric shock if your body is earthed or grounded.
- c) **Do not expose power tools to rain or wet conditions.** Water entering a power tool will increase the risk of electric shock.
- d) **Do not abuse the cord. Never use the cord for carrying, pulling or unplugging the power tool. Keep cord away from heat, oil, sharp edges or moving parts.** Damaged or entangled cords increase the risk of electric shock.
- e) **When operating a power tool outdoors, use an extension cord suitable for outdoor use.** Use of a cord suitable for outdoor use reduces the risk of electric shock.

## 3) Personal safety

- a) **Stay alert, watch what you are doing and use common sense when operating a power tool. Do not use a power tool while you are tired or under the influence of drugs, alcohol or medication.** A moment of inattention while operating power tools may result in serious personal injury.
- b) **Use safety equipment. Always wear eye protection.** Safety equipment such as dust mask, non-skid safety shoes, hard hat, or hearing protection used for appropriate conditions will reduce personal injuries.
- c) **Avoid accidental starting. Ensure the switch is in the off-position before plugging in.** Carrying power tools with your finger on the switch or plugging in power tools that have the switch on invites accidents.

## GENERAL SAFETY RULES continued

- d) **Remove any adjusting key or wrench before turning the power tool on.** A wrench or a key left attached to a rotating part of the power tool may result in personal injury.
- e) **Do not overreach. Keep proper footing and balance at all times.** This enables better control of the power tool in unexpected situations.
- f) **Dress properly. Do not wear loose clothing or jewelry. Keep your hair, clothing and gloves away from moving parts.** Loose clothes, jewelry or long hair can be caught in moving parts.
- g) **If devices are provided for the connection of dust extraction and collection facilities, ensure these are connected and properly used.** Use of these devices can reduce dust-related hazards.

### 4) Power tool use and care

- a) **Do not force the power tool. Use the correct power tool for your application.** The correct power tool will do the job better and safer at the rate for which it was designed.
- b) **Do not use the power tool if the switch does not turn it on and off.** Any power tool that cannot be controlled with the switch is dangerous and must be repaired.
- c) **Disconnect the plug from the power source before making any adjustments, changing accessories, or storing power tools.** Such preventive safety measures reduce the risk of starting the power tool accidentally.
- d) **Store idle power tools out of the reach of children and do not allow persons unfamiliar with the power tool or these instructions to operate the power tool.** Power tools are dangerous in the hands of untrained users.
- e) **Maintain power tools. Check for misalignment or binding of moving parts, breakage of parts and any other condition that may affect the power tools operation. If damaged, have the power tool repaired before use.** Many accidents are caused by poorly maintained power tools.
- f) **Keep cutting tools sharp and clean.** Properly maintained cutting tools with sharp cutting edges are less likely to bind and are easier to control.
- g) **Use the power tool, accessories and tool bits etc., in accordance with these instructions and in the manner intended for the particular type of power tool, taking into account the working conditions and the work to be performed.** Use of the power tool for operations different from those intended could result in a hazardous situation.











### 5) Service

- a) **Have your power tool serviced by a qualified repair person using only identical replacement parts.** This will ensure that the safety of the power tool is maintained.

## ADDITIONAL SPECIFIC SAFETY RULES

1. **Hold power tools by insulated gripping surfaces when performing an operation where the cutting tool may contact hidden wiring or its own cord.** Contact with a "live" wire will make exposed metal parts of the tool "live" and shock the operator.
2. **Sanding of lead-based paint is not recommended.** Lead-based paint should only be removed by a professional.
3. **Always maintain a firm grip on the sander handles** with both hands to prevent loss of control.
4. **Do not operate sander without all guards and covers** securely in place.
5. **Wear eye and hearing protection. Always use safety glasses.** Everyday eyeglasses are NOT safety glasses. USE CERTIFIED SAFETY EQUIPMENT. Eye protection equipment should comply with ANSI Z87.1 standards. Hearing equipment should comply with ANSI S3.19 standards.
6. **⚠️ WARNING Use of this tool can generate and disburse dust or other airborne particles, including wood dust, crystalline silica dust and asbestos dust.** Direct particles away from face and body. Always operate tool in well ventilated area and provide for proper dust removal. Use dust collection system wherever possible. Exposure to the dust may cause serious and permanent respiratory or other injury, including silicosis (a serious lung disease), cancer, and death. Avoid breathing the dust, and avoid prolonged contact with dust. Allowing dust to get into your mouth or eyes, or lay on your skin may promote absorption of harmful material. Always use properly fitting NIOSH/OSHA approved respiratory protection appropriate for the dust exposure, and wash exposed areas with soap and water.

**SAVE THESE INSTRUCTIONS!**

SYMBOL	DEFINITION
V	volts
A	amperes
Hz	hertz
W	watts
kW	kilowatts
F	farads
$\mu$ F	microfarads
l	litres
g	grams
kg	kilograms
bar	bars
Pa	pascals
h	hours
min	minutes
s	seconds
$n_0$	no-load speed
.../min or ...min <sup>-1</sup>	Revolutions or reciprocations per minute
 or d.c.	direct current
 or a.c.	alternating current
2 	two-phase alternating current
2N 	two-phase alternating current with neutral
3 	three-phase alternating current
3N 	three-phase alternating current with neutral
 A	rated current of the appropriate fuse-link in amperes
	time-lag miniature fuse-link where X is the symbol for the time/current characteristic, as given in IEC 60127
	protective earth
	class II tool
IPXX	IP symbol

**SAVE THESE INSTRUCTIONS!**

## ADDITIONAL SAFETY RULES FOR PAINT REMOVAL

### **▲WARNING**

Extreme care should be taken when removing paint. The peelings, residue, and vapors of paint may contain lead, which is poisonous. Exposure to even low levels of lead can cause irreversible brain and nervous system damage. Young and unborn children are particularly vulnerable.

Before beginning any paint removal process you should determine whether the paint you are removing contains lead. This can be done by your local health department or by a professional who uses a paint analyzer to check for lead.

### **Lead-based paint should only be removed by a professional.**

Persons removing paint should follow these guidelines:

- 1. Keep the work area well ventilated.** Open the windows and put an exhaust fan in one of them. Be sure the fan is moving air from inside to outside.
- 2. Remove or cover any carpets, rugs, furniture, clothing, cooking utensils, and air ducts.** Such preventive safety measures reduce the risk of exposure.
- 3. Place drop cloths in the work area to catch any paint chips or peelings. Wear protective clothing such as extra work shirts, overalls and hats.** Such preventive safety measures reduce the risk of exposure.
- 4. Work in one room at a time.** Furnishings should be removed or placed in the center of the room and covered. Work areas should be sealed off from the rest of the dwelling by sealing doorways with drop cloths.
- 5. Children, pregnant, or potentially pregnant women and nursing mothers should not be present in the work area until the work is done and all cleanup is complete.** Such preventive safety measures reduce the risk of injury.
- 6. Wear a dust respirator or a dual filter (dust and fume) respirator mask which has been approved by the Occupational Safety and Health Administration (OSHA), the National Institute of Safety and Health (NIOSH), or the United States Bureau of Mines.** These masks and replaceable filters are readily available at major hardware stores. Be sure the mask fits. Beards and facial hair may keep the masks from sealing properly. Change filters often. DISPOSABLE PAPER MASKS ARE NOT ADEQUATE.
- 7. Keep food and drink out of the work area.** Wash hands, arms, and face and rinse mouth before eating or drinking. Do not smoke or chew gum or tobacco in the work area.
- 8. Clean up all removed paint and dust by wet mopping the floors.** Use a wet cloth to clean all walls, sills and any other surfaces where paint or dust is clinging. DO NOT SWEEP, DRY DUST OR VACUUM. Use a high phosphate detergent or trisodium (TSP) to wash and mop areas.
- 9. At the end of each work session, put the paint chips and debris in a double plastic bag, close it with tape or twist ties and dispose properly.** Such preventive safety measures reduce the risk of exposure.
- 10. Remove protective clothing and work shoes in the work area to avoid carrying dust into the rest of the dwelling.** Wash work clothes separately. Wipe shoes off with a wet rag, then wash that rag with the work clothes. Wash hair and body thoroughly with soap and water.

**SAVE THESE INSTRUCTIONS!**



## MOTOR

Many Porter-Cable tools will operate on either D.C., or single phase 25 to 60 cycle A.C. current and voltage within plus or minus 5 percent of that shown on the specification plate on the tool. Several models, however, are designed for A.C. current only. Refer to the specification plate on your tool for proper voltage and current rating.

**CAUTION** Do not operate your tool on a current on which the voltage is not within correct limits. Do not operate tools rated A.C. only on D.C. current. To do so may seriously damage the tool.

## EXTENSION CORD SELECTION

If an extension cord is used, make sure the conductor size is large enough to prevent excessive voltage drop which will cause loss of power and possible motor damage. A table of recommended extension cord sizes will be found in this section. This table is based on limiting line voltage drop to 5 volts (10 volts for 230 volts) at 150% of rated amperes.

If an extension cord is to be used outdoors, it must be marked with the suffix W-A or W following the cord type designation. For example – SJTW-A to indicate it is acceptable for outdoor use.

RECOMMENDED EXTENSION CORD SIZES FOR USE WITH PORTABLE ELECTRIC TOOLS

		Length of Cord in Feet									
		115V	25 Ft.	50 Ft.	100 Ft.	150 Ft.	200 Ft.	250 Ft.	300 Ft.	400 Ft.	500 Ft.
		230V	50 Ft.	100 Ft.	200 Ft.	300 Ft.	400 Ft.	500 Ft.	600 Ft.	800 Ft.	1000 Ft.
Nameplate Ampere Rating	0-2	18	18	18	16	14	12	10	8	6	4
	2-3	18	18	16	14	12	10	8	6	4	2
	3-4	18	18	16	14	12	10	8	6	4	2
	4-5	18	18	14	12	10	8	6	4	2	2
	5-6	18	16	14	12	10	8	6	4	2	2
	6-8	18	16	12	10	8	6	4	2	2	2
	8-10	18	14	12	10	8	6	4	2	2	2
	10-12	16	14	10	8	6	4	2	2	2	2
	12-14	16	12	10	8	6	4	2	2	2	2
	14-16	16	12	10	8	6	4	2	2	2	2
	16-18	14	12	8	8	6	4	2	2	2	2
18-20	14	12	8	6	6	4	4	2	2	2	

**SAVE THESE INSTRUCTIONS!**

## CARTON CONTENTS

- \* Sander
- \* Standard sanding pad
- \* Profile mounting plates
- \* Set of 9 different sanding profiles
- \* Assorted profile sanding sheets
- \* Carrying case

## FUNCTIONAL DESCRIPTION

### FOREWORD

The Porter-Cable Profile Sander provides an “in-line” sanding motion that permits sanding of corners, profiles, and other areas that are inaccessible to other power sanders.

## ASSEMBLY

**NOTE:** This tool is shipped completely assembled. No assembly time or tools are required.

## OPERATION

### PREPARATION FOR SANDING

**NOTE:** A wide variety of accessory pads, profile holders, and profiles is available to fit the Porter-Cable Profile Sander. Please refer to your Porter-Cable Catalog to determine which of these items are supplied as standard equipment with each particular Profile Sander Package. All of these items are available as accessories, and they may be used with any Porter-Cable Model 444 Profile Sander.

### SELECTING A PAD OR PROFILE MOUNTING PLATE

Select the sanding pad or profile holder that best fits your application: Fig. 1.

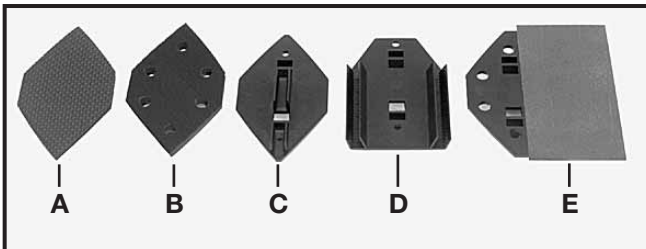

Fig. 1

**A. Diamond Pad for PSA Abrasives:** The pointed tip of this pad is used for sanding into corners and intricately shaped areas. Precut PSA abrasives are used with this pad (Fig. 2).

**B. Diamond Pad for Hook & Loop Abrasives:** The pointed tip of this pad is used for sanding into corners and intricately shaped areas. Precut, Hook & Loop Abrasives with dust extraction holes are used with this pad. The optional 14449 dust wand (and an external vacuum source), can also be used with this pad to provide dust collection (Fig. 3).



Fig. 2



Fig. 3

**C. Single Profile Mounting Plate:** This plate is used to mount any one of the profiles in a vertical position, centered under the Profile Sander (Fig. 4). Special PSA Abrasives are available in precut sheets or in rolls that can be cut-to-fit the various profiles.

**D. Angled Profile Mounting Plate:** This plate is used to mount any one of the profiles at a 30° outward angle on either the right or left side of the tool. (Fig. 5) This plate permits the profiles to be used in areas that are inaccessible with the Single Profile Mounting Plate. Special PSA Abrasives are available in precut sheets or in rolls that can be cut-to-fit the various profiles.

**E. Offset “Shutter” Pad:** This pad permits access to recessed surfaces, such as those found on louvered shutters. (Fig. 6) Special PSA Abrasives are available in rolls that can be cut-to-fit this pad.



Fig. 4

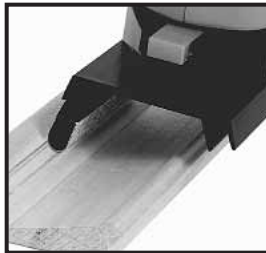

Fig. 5

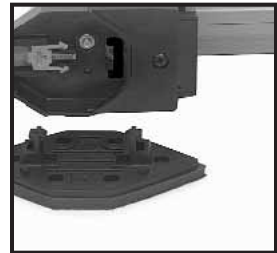

Fig. 6

## SELECTING A PROFILE

Individual Profiles are available in three basic styles. Several sizes are available in each style (see a Porter-Cable Catalog for a complete listing). The three basic styles are:

**Convex Profiles** Used to sand **concave surfaces**. Available in several sizes to match common configurations.

**Concave Profiles** Used to sand **convex surfaces**. Available in several sizes to match common configurations.

**Angled Profiles** Used to sand the bottom and sides of slots or grooves. Available in several angles to match common configurations.

## SELECTING THE ABRASIVE

The best finishes can be achieved by selecting the proper type of abrasive. coarser grit abrasives will remove the most material while finer grit abrasives will produce the best finishes.

Achieve best results by selecting the proper size and type of abrasives. Start the work with an abrasive grit just coarse enough to remove high spots and excessive roughness. Follow with a second sanding using a grit one or two grades finer. Continue using successively finer grits until the desired finish is obtained.

## ATTACHING PAD OR PROFILE MOUNTING PLATE

All of the accessory pads and profile mounting plates are attached to the tool in the same way. Each pad or mounting plate has two posts (A) Fig. 7 used to attach it to the Profile Sander.

One pad post fits into a pocket (B) Fig. 7 in the tool, and the other post is locked into place by a tab (C) Fig. 7. The mounting post area (of all the pads and mounting plates) is symmetrical. The pad (or mounting plate) can be attached to the Profile Sander with either end forward, which allows the use of both pointed ends of each sheet of pad abrasive, and permits the profile holders to be mounted in the best position for each particular application.

To attach a pad or mounting plate to the Profile Sander:

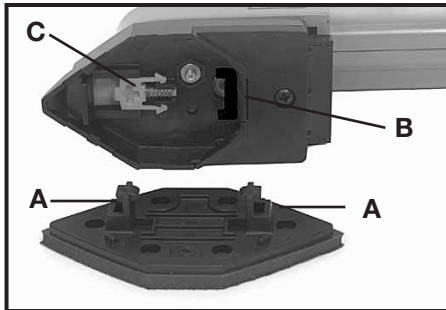

Fig. 7

1. **⚠ WARNING** **DISCONNECT TOOL FROM POWER SOURCE.**
2. Position one of the pad (or mounting plate) posts (A) Fig. 7 into the pocket (B) Fig. 7 of the Profile Sander (Fig. 8).
3. Depress latch button (D) Fig. 9, seat pad to sander, and release latch button to secure the pad in place (Fig. 10).
4. To remove pad (or mounting plate), depress latch button (D) Fig. 9, and pull pad away from sander.



Fig. 8

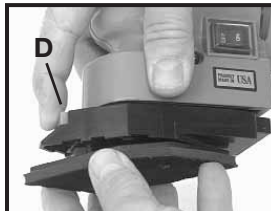

Fig. 9



Fig. 10

## ATTACHING PROFILE TO MOUNTING PLATE

Individual profiles may be mounted to either the Single Profile Mounting Plate, or the Angled Profile Mounting Plate (Figs. 11 and 12). The individual profiles are pressed into the slot on the mounting plate by hand, and can be removed from the mounting plate by pulling outward on one end of the profile.

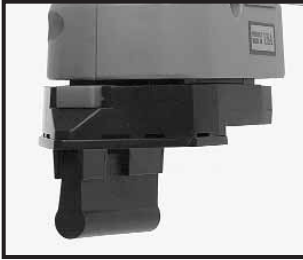

Fig. 11

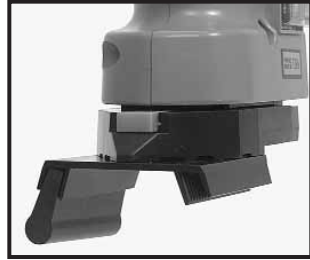

Fig. 12

## ATTACHING ABRASIVES

Three different types of abrasives that can be used with the Profile Sander are:

**HOOK & LOOP SHEETS:** These are precut sheets with hook & loop backing and dust extraction holes. This abrasive is used with the diamond shaped Hook & Loop Pad. Align the abrasive with the sander pad and press into place with the palm of your hand. Use a light twisting motion to lock the hooks into the loops. To remove abrasive, lift one corner with your fingernail and peel it off. These abrasives may be removed and reattached several times.

**PSA SHEETS:** These are precut sheets with pressure sensitive adhesive. Precut diamond shaped sheets are available to fit the optional diamond shaped PSA Pad. Precut rectangular sheets are available to fit all of the individual profiles. Peel the protective sheet from the back of the abrasive. Align the abrasive with the sander pad and press firmly into place. To remove abrasive, lift one corner with your fingernail and peel it off. Discard the used abrasive.

**PSA ROLLS:** These are 2<sup>1</sup>/<sub>2</sub>" wide rolls with pressure sensitive adhesive. This abrasive is used with the individual profiles and with the extended "shutter" pad. Unroll a strip of abrasive to fit the particular profile (or pad), and cut to length with scissors. **NOTE:** For best results, the abrasive should cover all of the exposed profile below the profile holder. Firmly press the abrasive in place on the profile (or pad). To remove abrasive, lift one corner with your fingernail and peel it off. Discard the used abrasive.

**NOTE:** PSA Pads and Profiles must be clean for the abrasives to adhere properly. Clean the pads and profiles with soap and water.

PSA Adhesives work best at temperatures above 25° F. If PSA abrasives, pads, or profiles are stored at lower temperatures, warm them before use.

Store PSA Pads in a dust-free environment to prevent contamination of the adhesive.

## ATTACHING OPTIONAL DUST WAND

**NOTE:** A wide variety of accessories, including a dust wand, is available for this tool. Please refer to your Porter-Cable Catalog to determine if the dust wand is supplied as standard equipment with your particular tool package. The dust wand is available as an accessory, and may be used with any Porter-Cable Model 444 Profile Sander.

The dust wand requires an external vacuum source (shop vac or dust collection system). To attach dust wand to sander:

1. Insert dust wand pin (A) Fig. 13 into hole (B) Fig. 13.
2. Thread knob (C) Fig. 14 into tool, and tighten firmly.
3. Connect the dust wand to your vacuum source with a 1" vacuum hose.

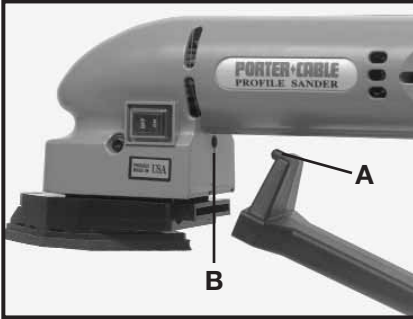

Fig. 13

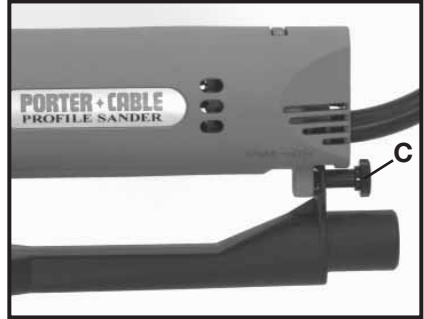

Fig. 14

## TO START AND STOP SANDER

The tool is equipped with a “rocker” type switch (A) Fig. 15 labeled “ON” and “OFF”.

1. Depress “OFF”. Check to see that the power circuit voltage is the same as that shown on the specification plate.
2. Connect Sander to power circuit.
3. While holding Sander firmly, and off the work surface, depress “ON”.
4. When you are finished sanding, lift the tool off the work and depress “OFF” to stop the tool.

## SPEED CONTROL (444VS only)

Model 444VS is equipped with a variable speed control. Operating speed is adjustable between 2100 SPM (Strokes Per Minute) and 6000 SPM.

Speed is adjustable by turning thumbwheel (B) Fig. 15A. Thumbwheel position #1 provides the slowest operating speed (2100 SPM) and position #6 the fastest (6000 SPM). Speed may be changed while motor is running or while stopped.

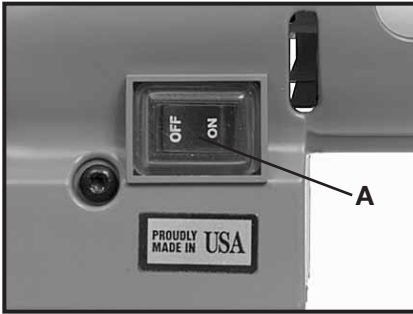

Fig. 15

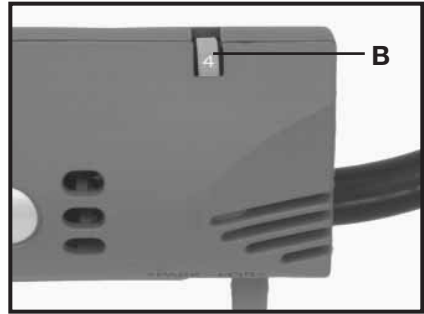

Fig. 15A

## USING THE SANDER

The Porter-Cable Profile Sander has been designed for one-hand operation (Fig. 16). The sander can be easily guided over the work surface with one hand. The normal weight of the machine is sufficient for efficient sanding. Additional pressure on the tool will slow down the speed of the pad, reduce the sanding efficiency, and put an additional burden on the motor.

The Profile Sander uses an “in-line” sanding motion. To achieve the best surface finish, sand “in-line” with the wood grain. Faster removal rates can be achieved by operating the sander across the grain while working out rough areas, and then finishing by sanding with the grain.



Fig. 16

## FINE FINISHING

The action of the tool causes thousands of tiny abrasive grits to move against the work at high speed. Each grain moves in the same direction and at a constant speed, causing the cutting action to be uniform over the entire pad surface. Start the work with an abrasive grit just coarse enough to remove the high spots and excessive roughness.

Follow with a second sanding using a grit one or two grades finer. Continue with successively finer grits until the desired finish is obtained. **DO NOT GO FROM A COARSE GRIT TO A VERY FINE GRIT IN ONE STEP.**

## REMOVING PAINT AND VARNISH

**CAUTION** Read and follow all instructions in the “**ADDITIONAL SAFETY RULES FOR PAINT REMOVAL**” section of this manual.

To remove old paint and varnish:

1. Use a coarse, open coat abrasive to avoid the usual clogging of the abrasive surfaces.
2. Keep the machine moving over new areas to avoid heating and softening the material being removed.

Try to work the entire surface at the same time by working in wide, overlapping arcs. Do not concentrate on small areas. When using liquid removers or heaters to speed the work, scrape away all excess paint or varnish with a putty knife or other suitable scraping tool, and allow the wood to be cool and dry before sanding.

## DOORS AND MOLDINGS

The “in-line” motion of the Profile Sander is ideally suited for use in the recessed corners and on the intricate profiles found on moldings and raised-panel doors. The diamond shaped pads make sanding the recessed corners easy, while the wide variety of available sanding profiles allow you to exactly match each detail of intricate molding configurations.

## TROUBLESHOOTING

For assistance with your tool, visit our website at [www.porter-cable.com](http://www.porter-cable.com) for a list of service centers or call the Porter-Cable help line at 1-800-487-8665.



## MAINTENANCE

### KEEP TOOL CLEAN

Periodically blow out all air passages with dry compressed air. All plastic parts should be cleaned with a soft damp cloth. NEVER use solvents to clean plastic parts. They could possibly dissolve or otherwise damage the material.

**▲WARNING** Wear ANSI Z87.1 safety glasses while using compressed air.

### FAILURE TO START

Should your tool fail to start, check to make sure the prongs on the cord plug are making good contact in the outlet. Also, check for blown fuses or open circuit breakers in the line.

### LUBRICATION

This tool has been lubricated with a sufficient amount of high grade lubricant for the life of the unit under normal operating conditions. No further lubrication is necessary.

### BRUSH INSPECTION (If applicable)

For your continued safety and electrical protection, brush inspection and replacement on this tool should ONLY be performed by an AUTHORIZED PORTER-CABLE SERVICE STATION or a PORTER-CABLE•DELTA FACTORY SERVICE CENTER.

At approximately 100 hours of use, take or send your tool to your nearest authorized Porter-Cable Service Station to be thoroughly cleaned and inspected. Have worn parts replaced and lubricated with fresh lubricant. Have new brushes installed, and test the tool for performance.

Any loss of power before the above maintenance check may indicate the need for immediate servicing of your tool. DO NOT CONTINUE TO OPERATE TOOL UNDER THIS CONDITION. If proper operating voltage is present, return your tool to the service station for immediate service.

## SERVICE

### REPLACEMENT PARTS

When servicing use only identical replacement parts. For a service parts list or to learn more about Porter-Cable visit our website at [www.porter-cable.com](http://www.porter-cable.com)

### SERVICE AND REPAIRS

All quality tools will eventually require servicing, or replacement of parts due to wear from normal use. For assistance with your tool, visit our website at [www.porter-cable.com](http://www.porter-cable.com) for a list of service centers or call the Customer Care Department at **1-800-487-8665**. All repairs made by our service centers are fully guaranteed against defective material and workmanship. We cannot guarantee repairs made or attempted by others.

Should you have any questions about your tool, feel free to write us at any time. In any communications, please give all information shown on the nameplate of your tool (model number, type, serial number, etc.).

## ACCESSORIES

A complete line of accessories is available from your Porter-Cable•Delta Supplier, Porter-Cable•Delta Factory Service Centers, and Porter-Cable Authorized Service Stations. Please visit our Web Site [www.porter-cable.com](http://www.porter-cable.com) for a catalog or for the name of your nearest supplier.

**⚠ WARNING** Since accessories other than those offered by Porter-Cable•Delta have not been tested with this product, use of such accessories could be hazardous. For safest operation, only Porter-Cable•Delta recommended accessories should be used with this product.

## WARRANTY

### PORTER-CABLE LIMITED ONE YEAR WARRANTY

Porter-Cable warrants its Professional Power Tools for a period of one year from the date of original purchase. We will repair or replace at our option, any part or parts of the product and accessories covered under this warranty which, after examination, proves to be defective in workmanship or material during the warranty period. For repair or replacement return the complete tool or accessory, transportation prepaid, to your nearest Porter-Cable Service Center or Authorized Service Station. Proof of purchase may be required. This warranty does not apply to repair or replacement required due to misuse, abuse, normal wear and tear or repairs attempted or made by other than our Service Centers or Authorized Service Stations.

ANY IMPLIED WARRANTY, INCLUDING THE IMPLIED WARRANTIES OF MERCHANTABILITY AND FITNESS FOR A PARTICULAR PURPOSE, WILL LAST ONLY FOR ONE (1) YEAR FROM THE DATE OF PURCHASE.

To obtain information on warranty performance please write to: PORTER-CABLE CORPORATION, 4825 Highway 45 North, Jackson, Tennessee 38305; Attention: Product Service. THE FOREGOING OBLIGATION IS PORTER-CABLE'S SOLE LIABILITY UNDER THIS OR ANY IMPLIED WARRANTY AND UNDER NO CIRCUMSTANCES SHALL PORTER-CABLE BE LIABLE FOR ANY INCIDENTAL OR CONSEQUENTIAL DAMAGES. Some states do not allow limitations on how long an implied warranty lasts or the exclusion or limitation of incidental or consequential damages, so the above limitation or exclusion may not apply to you.

This warranty gives you specific legal rights and you may also have other legal rights which vary from state to state.

# PORTER-CABLE • DELTA SERVICE CENTERS (CENTROS DE SERVICIO DE PORTER-CABLE • DELTA) (CENTRE DE SERVICE PORTER-CABLE • DELTA)

**Parts and Repair Service for Porter-Cable • Delta Power Tools are Available at These Locations  
(Obtenga Refaccion de Partes o Servicio para su Herramienta en los Siguientes Centros de Porter-Cable • Delta)  
(Locations où vous trouvez les pièces de rechange nécessaires ainsi qu'un service d'entretien)**

## ARIZONA

Tempe 85282 (Phoenix)  
2400 West Southern Avenue  
Suite 105  
Phone: (602) 437-1200  
Fax: (602) 437-2200

## CALIFORNIA

Ontario 91761 (Los Angeles)  
3949A East Guasti Road  
Phone: (909) 390-5555  
Fax: (909) 390-5554

San Diego 92111

7838 Clairemont Blvd.  
Phone: (858) 277-9595  
Fax: (858) 277-9696

San Leandro 94577 (Oakland)

3039 Teagarden Street  
Phone: (510) 357-9762  
Fax: (510) 357-7939

## COLORADO

Arvada 80003 (Denver)  
8175 Sheridan Blvd., Unit S  
Phone: (303) 487-1809  
Fax: (303) 487-1868

## FLORIDA

Davie 33314 (Miami)  
4343 South State Rd. 7 (441)  
Unit #107  
Phone: (954) 321-6635  
Fax: (954) 321-6638

Tampa 33609

4538 W. Kennedy Boulevard  
Phone: (813) 877-9585  
Fax: (813) 289-7948

## GEORGIA

Forest Park 30297 (Atlanta)  
5442 Frontage Road,  
Suite 112  
Phone: (404) 608-0006  
Fax: (404) 608-1123

## ILLINOIS

Addison 60101 (Chicago)  
400 South Rohlfing Rd.  
Phone: (630) 424-8805  
Fax: (630) 424-8895

Woodridge 60517 (Chicago)

2033 West 75th Street  
Phone: (630) 910-9200  
Fax: (630) 910-0360

## MARYLAND

Elkridge 21075 (Baltimore)  
7397-102 Washington Blvd.  
Phone: (410) 799-9394  
Fax: (410) 799-9398

## MASSACHUSETTS

Franklin 02038 (Boston)  
Franklin Industrial Park  
101E Constitution Blvd.  
Phone: (508) 520-8802  
Fax: (508) 528-8089

## MICHIGAN

Madison Heights 48071 (Detroit)  
30475 Stephenson Highway  
Phone: (248) 597-5000  
Fax: (248) 597-5004

## MINNESOTA

Minneapolis 55429  
5522 Lakeland Avenue North  
Phone: (763) 561-9080  
Fax: (763) 561-0653

## MISSOURI

North Kansas City 64116  
1141 Swift Avenue  
Phone: (816) 221-2070  
Fax: (816) 221-2897

St. Louis 63119

7574 Watson Road  
Phone: (314) 968-8950  
Fax: (314) 968-2790

## NEW YORK

Flushing 11365-1595 (N.Y.C.)  
175-25 Horace Harding Expwy.  
Phone: (718) 225-2040  
Fax: (718) 423-9619

## NORTH CAROLINA

Charlotte 28270  
9129 Monroe Road, Suite 115  
Phone: (704) 841-1176  
Fax: (704) 708-4625

## OHIO

Columbus 43214  
4560 Indianola Avenue  
Phone: (614) 263-0929  
Fax: (614) 263-1238

Cleveland 44125

8001 Sweet Valley Drive  
Unit #19  
Phone: (216) 447-9030  
Fax: (216) 447-3097

## OREGON

Portland 97230  
4916 NE 122 nd Ave.  
Phone: (503) 252-0107  
Fax: (503) 252-2123

## PENNSYLVANIA

Willow Grove 19090 (Philadelphia)  
520 North York Road  
Phone: (215) 658-1430  
Fax: (215) 658-1433

## TEXAS

Carrollton 75006 (Dallas)  
1300 Interstate 35 N, Suite 112  
Phone: (972) 446-2996  
Fax: (972) 446-8157

## WASHINGTON

Houston 77043  
4321 Sam Houston Parkway, West  
Suite 180  
Phone: (713) 983-9910  
Fax: (713) 983-6645

## WASHINGTON

Auburn 98001 (Seattle)  
3320 West Valley HWY, North  
Building D, Suite 111  
Phone: (253) 333-8353  
Fax: (253) 333-9613

Authorized Service Stations are located in many large cities. Telephone **800-487-8665** or **731-541-6042** for assistance locating one. Parts and accessories for Porter-Cable • Delta products should be obtained by contacting any Porter-Cable • Delta Distributor, Authorized Service Center, or Porter-Cable • Delta Factory Service Center. If you do not have access to any of these, call **888-848-5175** and you will be directed to the nearest Porter-Cable • Delta Factory Service Center. Las Estaciones de Servicio Autorizadas están ubicadas en muchas grandes ciudades. Llame al **800-487-8665** ó al **731-541-6042** para obtener asistencia a fin de localizar una. Las piezas y los accesorios para los productos Porter-Cable • Delta deben obtenerse poniéndose en contacto con cualquier distribuidor Porter-Cable • Delta, Centro de Servicio Autorizado o Centro de Servicio de Fábrica Porter-Cable • Delta. Si no tiene acceso a ninguna de estas opciones, llame al **888-848-5175** y le dirigirán al Centro de Servicio de Fábrica Porter-Cable • Delta más cercano. Des centres de service agréés sont situés dans beaucoup de grandes villes. Appelez au **800-487-8665** ou au **731-541-6042** pour obtenir de l'aide pour en repérer un. Pour obtenir des pièces et accessoires pour les produits Porter-Cable • Delta, s'adresser à tout distributeur Porter-Cable • Delta, centre de service agréé ou centre de service d'usine Porter-Cable • Delta. Si vous n'avez accès à aucun de ces centres, appeler le **888-848-5175** et on vous dirigera vers le centre de service d'usine Porter-Cable • Delta le plus proche.

## CANADIAN PORTER-CABLE • DELTA SERVICE CENTERS

### ALBERTA

Bay 6, 2520-23rd St. N.E.  
Calgary, Alberta  
T2E 8L2  
Phone: (403) 735-6166  
Fax: (403) 735-6144

### BRITISH COLUMBIA

8520 Baxter Place  
Burnaby, B.C.  
V5A 4T8  
Phone: (604) 420-0102  
Fax: (604) 420-3522

### MANITоба

1699 Dublin Avenue  
Winnipeg, Manitoba  
R3H 0H2  
Phone: (204) 633-9259  
Fax: (204) 632-1976

### ONTARIO

505 Southgate Drive  
Guelph, Ontario  
N1H 6M7  
Phone: (519) 767-4132  
Fax: (519) 767-4131

### QUÉBEC

1515 Ave.  
St-Jean Baptiste, Suite 160  
Québec, P.Q.  
G2E 5E2  
Phone: (418) 877-7112  
Fax: (418) 877-7123

1447, Begin  
St-Laurent, (Mtl), P.Q.  
H4R 1V8  
Phone: (514) 336-8772  
Fax: (514) 336-3505

The following are trademarks of PORTER-CABLE • DELTA (Las siguientes son marcas registradas de PORTER-CABLE • DELTA S.A.) (Les marques suivantes sont des marques de fabricant de la PORTER-CABLE • DELTA): Auto-Set®, BAMMER®, B.O.S.S.®, Builder's Saw®, Contractor's Saw®, Contractor's Saw II™, Delta™, DELTACRAFT®, DELTAGRAM™, Delta Series 2000™, DURATRONIC™, Emc2™, FLEX®, Flying Chips™, FRAME SAW™, Grip Vac™, Homcraft®, INNOVATION THAT WORKS®, Jet-Lock®, JETSTREAM™, 'kickstand', LASERLOC®, MICRO-SET®, Micro-Set®, MIDI LATHE®, MORTEN™, NETWORK™, OMNIJIG®, POCKET CUTTER®, PORTA-BAND®, PORTA-PLANE®, PORTER-CABLE®&(design), PORTER-CABLE®PROFESSIONAL POWER TOOLS, PORTER-CABLE REDEFINING PERFORMANCE™, Posi-Matic®, Q-3®&(design), QUICKSAND®&(design), QUICKSET™, QUICKSET II®, QUICKSET PLUS™, RIPTIDE™&(design), SAFE GUARD II®, SAFE-LOC®, Sanding Center®, SANDTRAP®&(design), SAW BOSS®, Sawbuck™, Sidekick®, SPEED-BLOC®, SPEEDMATIC®, SPEEDTRONIC®, STAIR EASE®, The American Woodshop®&(design), The Lumber Company®&(design), THE PROFESSIONAL EDGE™, THE PROFESSIONAL SELECT®, THIN-LINE™, TIGER®, TIGER CUB®, TIGER SAW®, TOROBUSTER®, TORQ-BUSTER®, TRU-MATCH™, TWIN-LITE®, UNIGUARD®, Unifence®, UNIFEEDE™, Unihead®, Uniplane™, Unirip®, Unisaw®, Univise®, Versa-Feeder®, VERSA-PLANE®, WHISPER SERIES®, WOODWORKER'S CHOICE™.

Trademarks noted with ™ and ® are registered in the United States Patent and Trademark Office and may also be registered in other countries. Las Marcas Registradas con el signo de ™ y ® son registradas por la Oficina de Registros y Patentes de los Estados Unidos y también pueden estar registradas en otros países. Marques déposées, indiquées par la lettre ™ et ®, sont déposées au Bureau des brevets d'invention et marques déposées aux Etats-Unis et pourraient être déposées aux autres pays.