



# HF MIFARE Easy Module

## USER MANUAL

© 2008 HID Global Corporation. All rights reserved.

**1506-USM-01-0-03**

**Firmware Version 1.0**

November 4, 2008

**Doc Number: 1506-USM-01, Rev A.0**

## **Warning - Read before start-up!**

---

- The product may only be used for the intended purpose designed by for the manufacturer. The operation manual should be conveniently kept available at all times for each user.
- Unauthorized changes that have not been sold or recommended by the manufacturer may have a negative influence on the system the program has been installed or copied on. Such unauthorized measures shall exclude any liability by the manufacturer.
- The liability-prescriptions of the manufacturer in the issue valid at the time of purchase are valid for the device. The manufacturer shall not be held legally responsible for inaccuracies, errors, or omissions in the manual or automatically set parameters for a device or for an incorrect application of a device.
- Only qualified personnel should carry out installation, operation, and maintenance procedures.
- Use of the program and its installation must be in accordance with national legal requirements.
- When working on devices the valid safety regulations must be observed.
- International copyrights are applicable to this program. Unauthorized copying, distribution or resale of this program or of parts of this program is a violation of applicable laws and will be prosecuted.

# Read Me First

---

## About This Guide

This manual describes the HF MIFARE Easy Read/Write Module. Its goal is to describe the reader, how it works, how to integrate it and how to use it.

## Contacts

### Europe, Middle East and Africa

HID Global Corporation, Ltd. (Haverhill, UK)  
email: [eusupport@hidglobal.com](mailto:eusupport@hidglobal.com)  
main: +44 (0) 1440 714 850  
support: +44 (0) 1440 711 822  
fax: +44 (0) 1440 714 840

## Contents

<b>Warning - Read before start-up!</b> .....	<b>2</b>
<b>Read Me First</b> .....	<b>3</b>
<b>Scope</b> .....	<b>6</b>
<b>Extended Documentation</b> .....	<b>6</b>
<b>Overview</b> .....	<b>6</b>
<b>1 Supported Tags</b> .....	<b>8</b>
<b>2 MIFARE® transponder family</b> .....	<b>9</b>
<b>3 Hardware</b> .....	<b>16</b>
<b>4 Software</b> .....	<b>22</b>
<b>5 Frequently Asked Questions</b> .....	<b>45</b>
<b>References</b> .....	<b>49</b>
<b>Appendix A: Compact P&amp;P Module</b> .....	<b>50</b>
<b>Appendix B: Short Range P&amp;P Module</b> .....	<b>55</b>
<b>Appendix C: Timings</b> .....	<b>59</b>
<b>Appendix D: Version History</b> .....	<b>60</b>
<b>Appendix E: Approvals / Certificates</b> .....	<b>61</b>

## List of Figures

Figure 2-1: State diagram.....	9
Figure 2-2: MIFARE® Standard: sector diagram .....	10
Figure 2-3: MIFARE® Standard: sector 0 / block 0.....	11
Figure 2-4: MIFARE® Standard: block 3, 7, 11, 15, .....	11
Figure 2-5: MIFARE® 4k sector index table .....	12
Figure 2-6: DESFire memory organization.....	13
Figure 2-7: DESFire State diagram .....	14
Figure 3-1: Pin out of J1 .....	17
Figure 3-2: Electrical characteristics of pins.....	17
Figure 3-3: Pin out of J2 .....	18

---

Figure 3-4: Electrical characteristics of pins.....	19
Figure 4-1: ASCII protocol frame .....	22
Figure 4-2: Binary Frame .....	22
Figure 4-3: EEPROM memory .....	24
Figure 4-4: Protocol configuration register .....	25
Figure 4-5: Baud rate register .....	26
Figure 4-6: Baud rate settings.....	26
Figure 4-7: Communication settings .....	26
Figure 4-8: Command overview .....	27
Figure 4-9: Error codes .....	28
Figure 4-10: Time slot formula .....	32
Figure 4-11: Timing diagram of time slotted answers .....	33
Figure 4-12: Read USER port return values .....	37
Figure 4-13: Write User port settings .....	38
Figure 5-1: Using a MIFARE® card .....	48
Figure 5-2: Get a serial number from NFC.....	48

## Scope

---

The MIFARE<sup>®</sup> Application Oriented Protocol is a reader Interface to communicate with MIFARE<sup>®</sup> transponders. The major applications to be supported are:

- Access control, Identification: Reading the serial numbers of all cards in the field.
- Data Storage: Performing encrypted read and write operations.
- Ticketing: Performing read, write, increment and decrement operations in an encrypted environment.
- Multi applications: Performing read, write, increment and decrement operations on various sectors of the MIFARE<sup>®</sup> Standard tags using different encryption keys.

## Extended Documentation

---

**Note:** All confidential materials are not part of this documentation.

You can obtain extended documentation containing that material after signing a NDA.

## Overview

---

### Definitions

#### Anti-collision loop

Algorithm processed to identify and handle a dialogue between reader and one or more tags in its antenna field.

#### Hex notation

A hexadecimal value is noted with a following h, for example A1h has the value A1 hexadecimal.

#### ASCII notation

ASCII characters are listed within apostrophes, for example 'x' means a single x.

## Abbreviations

Abbreviation	Description
ASCII	American Standard Code for Information Interchange
block	For MIFARE® Standard one block contains 16 bytes
EOF	End of frame
hex / xxh	value in Hexadecimal notation
LSB	Least Significant Bit or Byte
MSB	Most Significant Bit or Byte
PCON	Protocol Configuration byte of the reader
REQA	Request ISO Type A
RFU	Reserved for Future Use
sector	For MIFARE® Standard one sector contains 4 blocks
SID	Station ID
SN	Serial Number of a tag
SOF	Start of frame
value block	32 bit data block format. Used in ticketing application
<CR>	Carriage return (0Dh)
<LF>	Line feed (0Ah)

# 1 Supported Tags

	Manufacturer	Serial number	Read block	Write block	Transfer command	Comments
MIFARE® Standard	Philips	√	√	√	√	
MIFARE® 4k	Philips	√	√	√	√	
MIFARE® Ultralight	Philips	√	√	√	√	
MIFARE® ProX	Philips	√	√	√	√	
MIFARE® DESFire	Philips	√	-	-	√	encryption not included
MIFARE® Smart MX	Philips	√	-	-	√	
SLE44R35S	Infineon	√	√	√	√	
SLE55R04/08/16	Infineon	√	-	-	√	encryption not included
SLE66R35	Infineon	√	√	√	√	



## 2 MIFARE<sup>®</sup> transponder family

The MIFARE<sup>®</sup> transponder family consists of various 13.56 MHz transponders IC, all according to ISO 14443.

### 2.1 State Diagram

All MIFARE<sup>®</sup> cards use following state diagram.

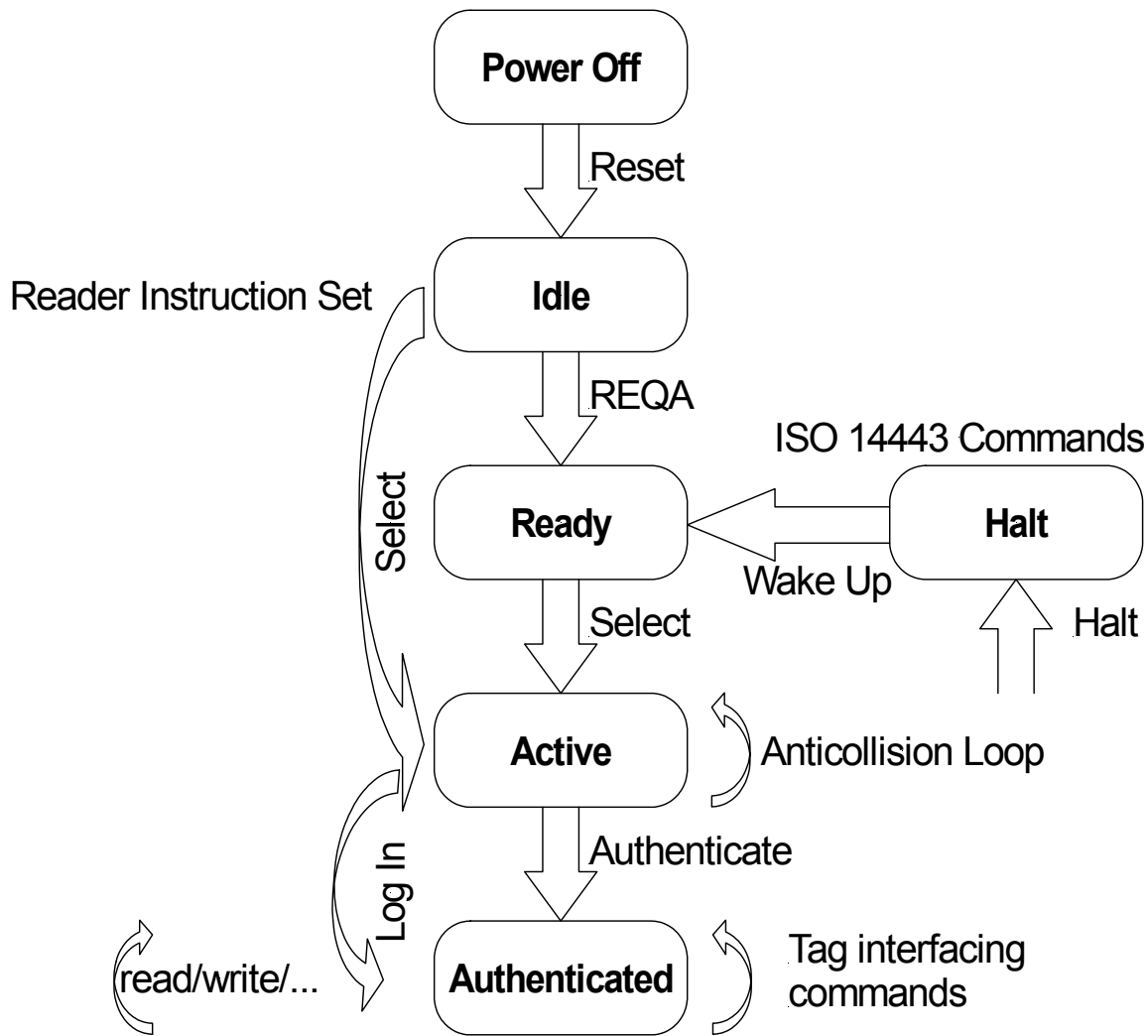

Figure 2-1: State diagram

## 2.2 MIFARE® Standard

The MIFARE® Standard card consists of 16 sectors. A sector includes four blocks 16 bytes each.

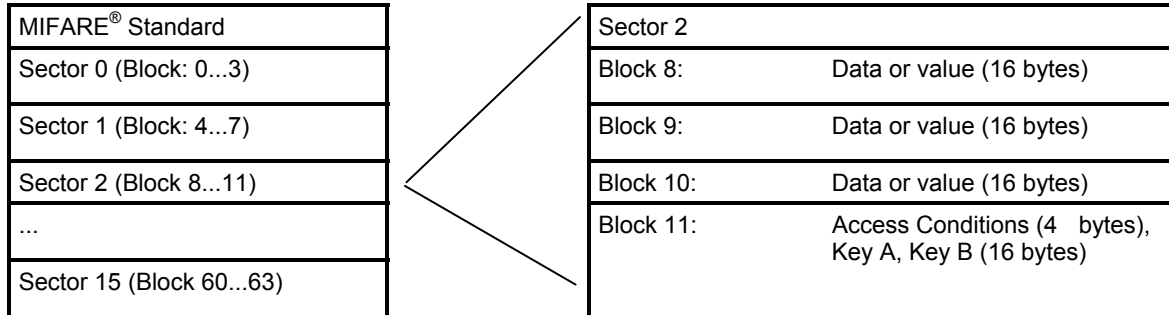

Figure 2-2: MIFARE® Standard: sector diagram

### 2.2.1 Definitions

Sector	Memory segment of the MIFARE® Standard Card. Each segment consists of 4 blocks and has individual keys and access conditions. Typically in a multi-application environment, each block is assigned to an application.
Key	6 byte structure assigned to each sector of the card. The reader may store up to 32 keys in its EEPROM or one key in its RAM.
Transport Key	Key as stored after delivery from the manufacturer.(for example A0A1A2A3A4A5, B0B1B2B3B4B5 or FFFFFFFFFF)
Block	16 byte memory segment of the MIFARE® Standard card.
Value	4 byte (unsigned long) variable stored in a special format in a block or page. Values are 2s complement numbers that can be negative also. Values are used for cashless payment. Values consume a complete block each using redundancy for integrity checking.
Card ID	4 byte unique serial number (single size type). Together with manufacturer code and check byte 16 bytes. Read-only. It is stored in block 0 (sector 0) of each tag.

### 2.2.2 Sector 0 / Block 0

Block 0 is read only.

Serial Number (4 byte)	Check byte (1 byte)	Manufacturer data (11 byte)
------------------------	---------------------	-----------------------------

Figure 2-3: MIFARE® Standard: sector 0 / block 0

### 2.2.3 Block 3, 7, 11, 15 ...

Transport keys are set on delivery:

Key A (6 byte)	Access Conditions (4 bytes)	Key B (6 byte)
----------------	-----------------------------	----------------

Figure 2-4: MIFARE® Standard: block 3, 7, 11, 15, ...

#### Key A

A0 A1 A2 A3 A4 A5 (Infineon) or FF FF FF FF FF FF (new Philips cards)

#### Key B

B0 B1 B2 B3 B4 B5 (Infineon) or FF FF FF FF FF FF (new Philips cards)

#### Access Conditions

FF 07 80 xx (key A used to read or write, the key A itself is not readable; key B is data only). For further information refer to Frequently asked questions or MIFARE® card manual.

#### Remarks

Enabled keys are always read as 00 00 00 00 00 00

Using key B as data area will cause a security gap, due to the fact that it is necessary to rewrite key A and access conditions each write process. It is not recommended to use it as data storage.

## 2.3 MIFARE® Ultralight

MIFARE® Ultralight cards have no encryption included. They only support plain text data transmission.

MIFARE® Ultralight are only supporting 4 byte per sector, but the command set uses 16 byte per sector. Only the 4 least significant bytes are valid when using MIFARE® Ultralight.

Ensure that the other bytes matching with tag content when using the write command, otherwise the read back will fail.

## 2.4 MIFARE® 4k

MIFARE® 4k cards have an increased memory. Beginning from sector 32 (20h) a sector has 16 blocks. Due to compatibility reasons the sector indices has changed according following figure. The login sector has to be used to access the according sector on the card.

Sector	Block	Login sector
00h	00h – 03h	00h
01h	04h – 07h	01h
...	...	...
1Fh	7Ch – 7Fh	1Fh
20h	80h – 8Fh	20h
21h	90h – 9Fh	24h
22h	A0h – AFh	28h
23h	B0h – BFh	2Ch
24h	C0h – CFh	30h
25h	D0h – DFh	34h
26h	E0h – EFh	38h
27h	F0h – FFh	3Ch

Figure 2-5: MIFARE® 4k sector index table

## 2.5 MIFARE® ProX

MIFARE® ProX tags have an operating system onboard. Data organization depends on the operating system installed on the card. These cards can include additional functionalities such as DES or a proprietary encipher algorithm.

Prior to any access of the operating system the card must be selected. Customized commands are issued using the transfer command.

## 2.6 MIFARE® DESFire

This tag supports additional security algorithms (DES, Triple-DES, MAC) for security sensitive applications.

DESFire tags are addressed using a specific command set (see DESFire command set).

### 2.6.1 Memory organization

The memory of a DESFire card can be personalized to own requirements. The card can be seen as data storage like a hard disk in a PC. The memory is divided in up to 28 different applications (directories) and with 16 files each. An application has up to 14 keys. Depending on keys and access conditions a file can be accessed in four different ways. Plain data is never secured. Data is secured using a MAC, single DES or triple DES enciphers.

Following figure describes the memory organization of a DESFire card.

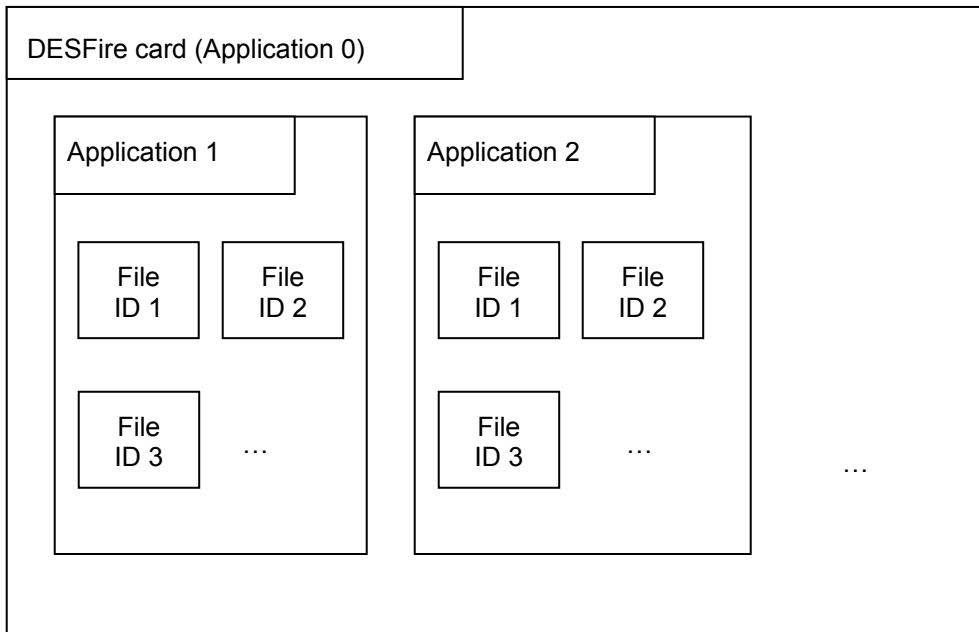

Figure 2-6: DESFire memory organization

## 2.6.2 State diagram of DESFire

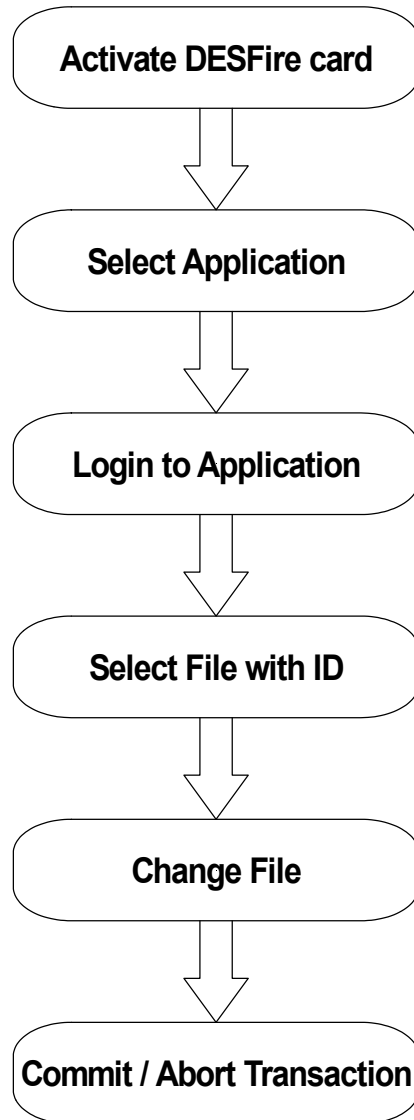

Figure 2-7: DESFire State diagram

### 2.6.2.1 Activate PICC

Prior to any access to a DESFire card the card must be selected. A DESFire card has 7 bytes UID. After activation the card is powered up and ready to accept a DESFire command. Application 0 is selected automatically.

### 2.6.2.2 Select application with ID

To jump into another application it has to be selected. An application can be seen as a directory, which contains up to 16 files. The size of the application depends on the stored files.

---

### **2.6.2.3 Login to application**

Each application can be set to specific access rights. A login to an application allows changing the application organization. Login to a file opens a secured file for access. A file can be accessed in four different ways: plain with no security, secured with MAC, single DES or triple DES.

### **2.6.2.4 Select file with ID**

Prior to any access to a file a file must be selected

### **2.6.2.5 Change file**

A selected file can be changed according its access rights. If a file is secured a login is needed before.

### **2.6.2.6 Commit/ Abort transaction**

Value files, backup files, linear record files and cyclic record files only adapt its value after the commit transaction command. Several files can be changed within an application at the same time. The abort transactions command is where all changes within an application are annulated. Power loss will cancel all modifications too.

For more details about the application settings and access rights refer to [2].

### 3 Hardware

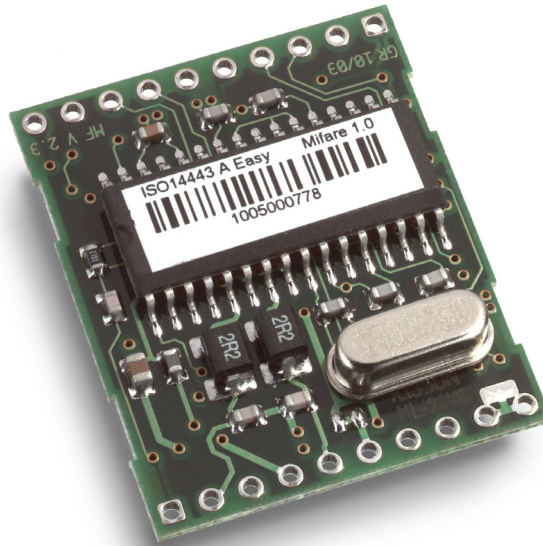

#### 3.1 Dimensions

All dimensions are listed in mm.

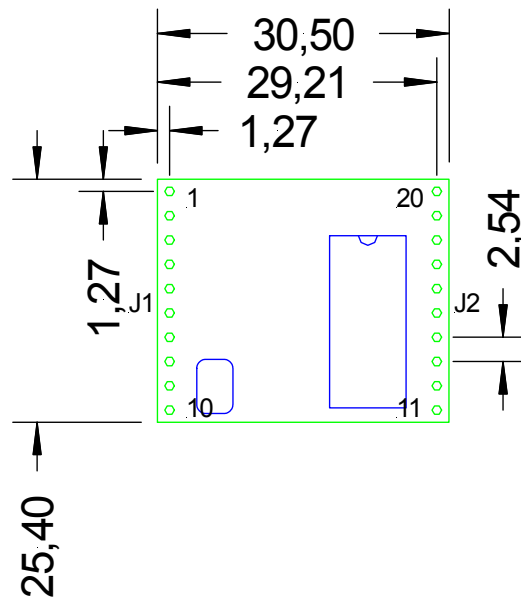

Top view



### 3.1.1 Pin out of J1

PIN	PIN No.	Description
ARX	1	Antenna RX
ATX1	2	Antenna TX1
VDD	3	Supply Voltage
GND	4	Ground
ATX2	5	Antenna TX2
TGND	6	Antenna Ground
RFU	7	Reserved for future use
RFU	8	Reserved for future use
RFU	9	Reserved for future use
RFU	10	Reserved for future use

Figure 3-1: Pin out of J1

### 3.1.2 Electrical characteristics of J1 PINS

PIN	PIN No.	Min	Typ.	Max.	Description
ARX	1	1.1V		4.4V	Antenna RX
ATX1	2		13,56 MHz 34 V <sub>PP</sub>	13.56MHz 100 mA <sub>PP</sub> 50V <sub>PP</sub>	Antenna TX1
VDD	3	+4.5V	+5.0V	+5.5V	Supply Voltage
		32mA	150mA	250mA	Supply Current
GND	4		GND		Ground
ATX2	5		13,56 MHz 34 V <sub>PP</sub>	13.56MHz 100 mA <sub>PP</sub> 50V <sub>PP</sub>	Antenna TX2
TGND	6		GND		Antenna Ground
RFU	7				Do not connect
RFU	8				Do not connect
RFU	9				Do not connect
RFU	10				Do not connect

Figure 3-2: Electrical characteristics of pins

### 3.1.3 Pin out of J2

PIN	PIN No.	Description
RX	11	RX from PC
TX	12	TX to PC
DIR	13	Direction of RS 485
USER	14	User Port
RES	15	Hardware reset if logic low
EN	16	Enable reader, open or logic high
LED <sub>r</sub>	17	LED red
LED <sub>g</sub>	18	LED green (reading LED)
GND	19	Ground
VDD	20	Supply Voltage

Figure 3-3: Pin out of J2

### 3.1.4 Electrical characteristics of J2 PINs

PIN	PIN No.	Min	Typ.	Max.	Description
RX	11		USART-TTL <sup>1</sup>	25 mA	RX to PC To RS232, RS485 or RS422 device driver
TX	12		USART-TTL <sup>1</sup>	25 mA	TX to PC To RS232, RS485 or RS422 device driver
DIR	13		TTL	25 mA	Direction of RS 485 Logic High = Reader to Host Logic Low = Host to Reader
USER	14		TTL <sup>2</sup>	25 mA	User Port
RES	15		TTL <sup>3</sup>		On logic low, hardware will be reset
EN	16		TTL <sup>4</sup>	25 mA	Enable reader logic low will disable the reader Open or logic high
LED <sub>r</sub>	17	VDD <sub>min</sub> @ 25mA	VDD <sub>typ</sub> @ 11mA	VDD <sub>max</sub> @ 0 mA	LED red Output Voltage
			11mA	25mA	External Resistor min. 200 Ω

<sup>1</sup> Universal Synchronous Asynchronous Receiver Transmitter

<sup>2</sup> TTL buffer output / input

<sup>3</sup> Voltage spikes below GND at the RES/V<sub>DD</sub> pin, including currents greater than 80mA, may cause latch-up. Thus, a series resistor of 50-100Ω should be used when applying a "low" level to the RES/V<sub>DD</sub>, rather than pulling this pin directly to GND.

<sup>4</sup> Schmitt trigger buffer input

PIN	PIN No.	Min	Typ.	Max.	Description
LEDg	18		1.4V @ 11mA	VDD @ 0mA	LED green (reading LED) with 330 Ω (internal serial) resistor
			11mA	15mA	
GND	19		GND		Ground
VDD	20	+4.5V	+5.0V	+5.5V	Supply Voltage
IDD		32 mA	150 mA	250 mA	Supply Current

Figure 3-4: Electrical characteristics of pins

### 3.1.5 External Connections

#### 3.1.5.1 Power Supply

If the supply voltage and any noise modulated on the supply voltage remains within the specified limits, no further filtering is required. In some cases it is recommended to use additional filtering for the power supply line. Insufficient power line filtering could cause unexpected or irregular performance drops.

##### Option 1

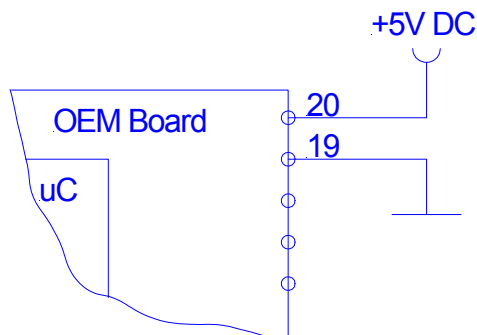

##### Option 2

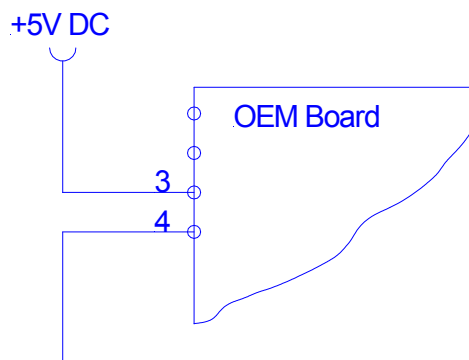

The board can be connected as shown above. Both alternatives are possible and can be used as they fit best into the layout of the carrier board. The two VDD PINs and the two GND PINs are connected internally.

### 3.1.5.2 Antenna

The typical antenna tuning and matching network is shown below. The external antenna has to have the right inductance and a certain resistor and capacitor combination for an optimized frequency tuning and antenna matching.

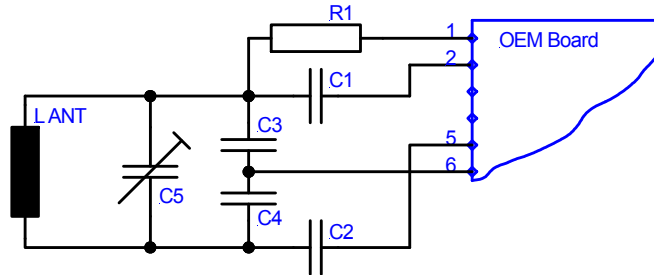

More details about the antenna design are available in the Antenna Design guide manual. This document can be downloaded from [www.hidglobal.com](http://www.hidglobal.com).

Please refer also to the specific application notes for the Philips reader IC (MIFARE® & I-Code, Micore Reader IC family Directly Matched Antenna Design).

### 3.1.5.3 Serial Interface

The OEM Board can be connected directly with a micro controller. Alternatively the OEM Board also can be connected to most serial interface types by using the right interface converter circuit. In order to optimize the communication quality the specific application note of the interface converter circuit needs to be taken into consideration.

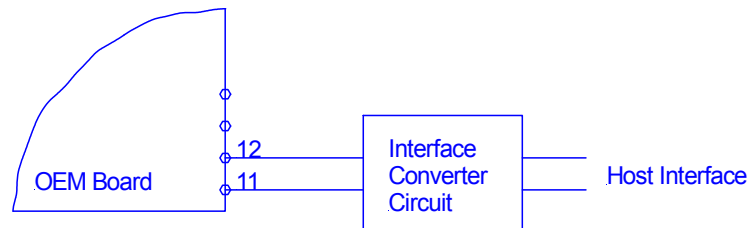

### 3.1.5.4 Function Control LEDs

Two external LEDs can be connected to the OEM Board. There are two alternatives possible.

#### Option 1

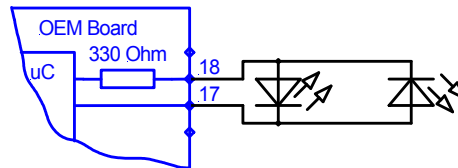

#### Option 2

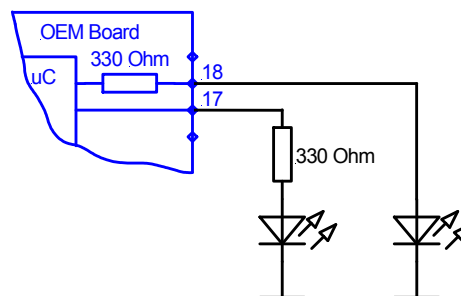

In both cases the LED supply voltage levels are TTL levels.

## 4 Software

As default data is transmitted at 9600,n, 8,1, no handshaking. Two protocol modes are supported. The protocol mode is configured in the reader EEPROM. As factory default, the ASCII protocol is used.

### 4.1 ASCII Protocol

This protocol is designed for easy handling. The commands are issued using a terminal program. Data is transmitted as ASCII hexadecimal that can be displayed on any terminal program (for example HyperTerminal).

Command	Data
Various length	Various length

Figure 4-1: ASCII protocol frame

### 4.2 Binary Protocol

This protocol is designed for industrial applications with synchronization and frame checking. Also an addressing byte for party line (master slave, multi drop) is included.

The protocol usually requires a device driver. Data is transmitted binary. The reader uses a binary watchdog timer internally to ensure correct framing.

STX	Station ID	Length	Data	BCC	ETX
1 byte	1 byte	1 byte	Various length	1 byte	1 byte

Figure 4-2: Binary Frame

#### 4.2.1 STX

Start of transmission (02h)

#### 4.2.2 Station ID

Unique ID of the station

00h: reserved for the bus master. Readers send response to this device ID.

FFh: Broadcast message. All devices will execute the command and send its response.

#### 4.2.3 Length

Data Length Indicator.

Denotes the length of the Data block.

#### 4.2.4 Data

This part contains the command and data. The command values are the same as in ASCII protocol mode ('x', 's', ...) whereas data is transmitted binary.

The length of the command block depends on the instruction.

#### 4.2.5 Block Check Character (BCC)

The BCC is used to detect transmission errors. The BCC is calculated XOR-ing each byte of the transmission frame excluding the STX/BCC and ETX character.

$$BCC = (StatID) XOR (Length) XOR (Data_0) XOR \dots XOR (Data_N)$$

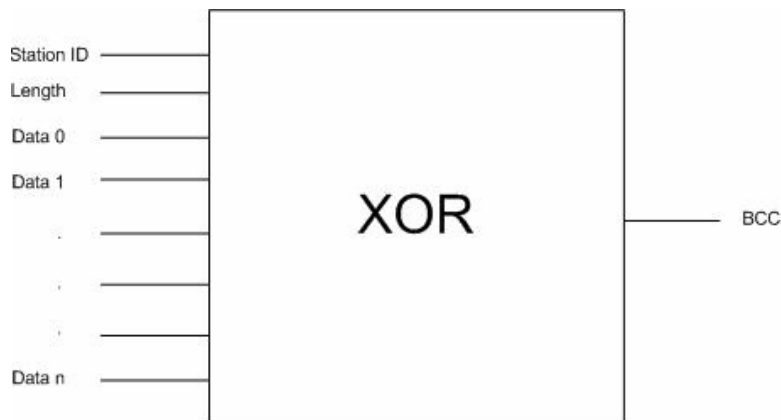

#### 4.2.6 ETX

End of transmission. (03h)

#### 4.2.7 Remarks

If the reader device receives an invalid instruction frame (for example BCC wrong) or the requested station ID does not match the internal ID of the reader, the command is not executed. The reader waits for the next valid frame.

The automatic binary timeout (see protocol configuration register) is used to detect incomplete binary frames.

The reader module answers in the same telegram format, with the ID-field set to 0. The Data block of the answers in binary protocol mode does match the ASCII mode answers, with the only difference that data values are transmitted binary instead of ASCII Hex.

## 4.2.8 Examples

02h	64h	01h	78h	1Dh	03h
STX	Station ID	Length	'x'	BCC	ETX

This instruction frame will reset the reader module with the station ID 64h.

## 4.3 Register Set

The reader has several system flags to customize its behavior. The flags are stored non-volatile in its EEPROM. The reader accepts changes of the setting only during the start up phase. It is recommended to clear all RFU bits to guarantee further compatibility.

The reader is able to store up to 32 authentication keys to log in Standard MIFARE® cards internally. All keys are read only and cannot be accessed via the interface lines.

### 4.3.1 EEPROM memory organization

Register	Description
00h ... 03h	Unique device ID; read only
04h	Station ID
05h	Protocol configuration
06h	Baud rate
07h	Reset Off Time
08h	Reset Recovery time
09h	Internal use / Do no change
0Ah ... 0Fh	RFU
10h ... 13h	User data

Figure 4-3: EEPROM memory

### 4.3.2 Unique device ID (00h – 03h)

The unique device ID identifies a reader module. It is factory programmed and cannot be changed.

### 4.3.3 StationID (04h)

The station ID is used in binary mode to address a device in party line set up. The station ID has the range of 01h to FEh and can be set freely. The value 00h is reserved for the bus master. All readers send their response to this device.

The broadcast message (FFh) forces all readers to response to the command.

Default value is 01h.



#### 4.3.4 Protocol configuration (05h)

The protocol configuration register (PCON) specifies general behavior of the reader device.

Default value is 01h.

Protocol configuration register							
Bit 7	Bit 6	Bit 5	Bit 4	Bit 3	Bit 2	Bit 1	Bit 0
RFU	RFU	RFU	Multitag	Binary Timeout	Extend ID	Binary	Auto Start

Figure 4-4: Protocol configuration register

##### 4.3.4.1 Autostart (default 1)

If set the reader device will start up in continuous read mode automatically.

##### 4.3.4.2 Protocol (default 0)

If set the reader uses binary protocol mode. Refer to binary protocol for further information on the binary protocol format.

Default setting = ASCII protocol (0).

Extended ID (default 0)

This setting does only affect the commands continuous reading ('c'), select ('s') and multi tag select ('m').

If set a the unique serial number of the transponder is extended by a single prefix byte.

The values for the prefix byte are:

prefix	description
01h	MIFARE® Light Transponder
02h	MIFARE® Standard Transponder
03h	MIFARE® 4k Transponder
04h	MIFARE® ProX Transponder
05h	MIFARE® UltraLight Transponder
06h	MIFARE® DESFire Transponder
FFh	Unknown Transponder

##### 4.3.4.3 Binary Timeout (default 0)

This flag is only interpreted if the reader operates in binary mode.

If the serial bus stays idle for more than 96 ms (no data is transmitted), the reader will clear its command buffer and enter "Command Read" mode.

The "Command Read" mode means that the reader is waiting for valid data frames (beginning with the STX code).

#### 4.3.4.4 Multitag (default 0)

The Multitag flag will enable multi tag recognition in continuous read mode. All tags are detected and displayed. Due to the more complex search algorithm the continuous read command decreases its detection speed.

#### 4.3.5 BAUD, Baud rate control register (06h)

The baud rate register defines the communication speed of the reader device.

Default value is 00h.

Baud rate register							
Bit 7	Bit 6	Bit 5	Bit 4	Bit 3	Bit 2	Bit 1	Bit 0
RFU	RFU	RFU	RFU	RFU	RFU	BS1	BS0

**Figure 4-5: Baud rate register**

This register defines the baud rate of the device.

BS1	BS0	Baud rate
0	0	9600 baud (default)
0	1	19200 baud
1	0	38400 baud
1	1	57600 baud

**Figure 4-6: Baud rate settings**

Following figure describes the communication settings

Description
8 data bits
No parity bit
1 stop bit
No flow control

**Figure 4-7: Communication settings**

#### 4.3.6 Reset Off Time (07h)

The Reset Off Time register represents the field off time in ms.

This register is used for the select, continuous read and multi tag commands.

Default value is 10h.

#### 4.3.7 Reset Recovery Time (08h)

The Reset Recovery Time register represents the recovery time in ms after the field is turned on.

This register is used for the select, continuous read and multi tag commands.

Default value is 10h.

### 4.3.8 User data (10h - 13h)

These registers are for free use.

## 4.4 Instruction Set

Following table describes all commands of the reader device. Each command returns an answer to the host. Exceptions are mentioned explicitly. The green LED is acknowledging a successfully executed command. The red LED indicates an error.

### 4.4.1 Overview

Common commands	
'+'	Increment value block (credit)
'.'	Decrement value block (debit)
'='	Copy value block (backup)
'c'	Continuous read
'g'	Get Station ID
'l'	Login (authenticate tag)
'm'	MultiTag select / tag list
'poff' / 'pon'	Antenna power off/on
'pr' / 'pw'	Read / write user port
'r' / 'rb'	Read block
're'	Read EEPROM register
'rv'	Read value block
's'	Select
'v'	Get version
'w' / 'wb'	Write block
'we'	Write EEPROM register
'wm'	Write master key
'wv'	Write value block
'x'	Reset

Figure 4-8: Command overview

## 4.4.2 Error Codes

Following figure shows an overview of all error messages of the reader device.

Error Code	Description
'?	Unknown command
'E'	Invalid key format
'F'	General failure
'I'	Invalid value format, specified block does not match the value format
'N'	No tag in the field
'O'	Operation mode failure
'U'	Read after write failure
'X'	Authentication failed

Figure 4-9: Error codes

## 4.4.3 Common commands

### 4.4.3.1 Increment value block (credit)

Increments a value block with a defined value. A read after write is done automatically to verify data integrity. The command fails if the source block is not in value block format. A previous log in is needed to access a block.

#### Command

Command	Data
'+'	Block (1 byte) Value (4 bytes)

#### Answer

Answer	Description
Data	Value (4 bytes)
'I'	Error: value block failure
'F'	Error: increment failure
'N'	Error: No tag in field
'X'	Error: Unable to read after write

#### Example

Command	Description
+0400000001	adds 1 to value block 4
+0500000100	adds 256 to value block 5

#### 4.4.3.1.1 No value block 'I'

Specified block does not match the value format. The value block is corrupted. A backup block can be used to restore the correct value.

#### 4.4.3.1.2 Increment failure 'F'

General failure during increment procedure or unable to read after write.

#### 4.4.3.1.3 No tag error 'N'

The reader does not detect a response of the tag. There is either no tag present or the tag does not respond the request.

#### 4.4.3.1.4 Unable to read after write 'X'

The tag was removed from field immediately after increment instruction.

Data was decremented but the tag did not respond to the read after increment instruction, which is done automatically by the reader module.

#### 4.4.3.2 Decrement value block (debit)

Decrements a value block with a defined value. A read after write is done automatically to verify data integrity. The command fails if the source block is not in value block format. A previous log in is needed to access a block.

##### Command

Command	Data
'L'	Block (1 byte) Value (4 bytes)

##### Answer

Answer	Description
Data	Value (4 bytes)
'I'	Error: value block failure
'F'	Error: increment failure
'N'	Error: No tag in field
'X'	Error: Unable to read after write

##### Example

Command	Description
-0400000001	subtract 1 to value block 4
-0500000100	subtract 256 to value block 5

#### 4.4.3.2.1 No value block 'I'

Specified block does not match the value format. The value block is corrupted. A backup block can be used to restore the correct value.

#### 4.4.3.2.2 Decrement failure 'F'

General failure during decrement procedure or unable to read after write.

#### 4.4.3.2.3 No tag error 'N'

The reader does not detect a response of the tag. There is either no tag present or the tag does not respond the request.

**4.4.3.2.4 Unable to read after write 'X'**

The tag was removed from field immediately after decrement instruction.

Data was decremented but the tag did not respond to the read after decrement instruction, which is done automatically by the reader module.

**4.4.3.3 Copy value block (backup)**

Copies a value block to another block of the same sector. A read after write is done automatically to ensure data integrity. Used for backup and error recovery. A previous log in is needed to access a block.

**Command**

Command	Data
'='	Source block (1 byte) Target block (1 byte)

**Answer**

Answer	Description
Data	New value of target block (4 bytes).
'I'	Error: value block failure
'F'	Error: increment failure
'N'	Error: No tag in field
'X'	Error: Unable to read after write

**Example**

Command	Description
=0405	copy value block 4 to block 5
=0506	copy value block 5 to block 6

**4.4.3.3.1 Target block**

The target block needs not to be a valid value block. If source block is not in value format the command fails.

**4.4.3.3.2 No value block 'I'**

Source value block does not match the value format. The value block is corrupted. A backup block can be used to restore the correct value.

**4.4.3.3.3 Copy failure 'F'**

General failure during copy procedure or unable to read after write.

**4.4.3.3.4 No tag error 'N'**

The reader does not detect a response of the tag. There is either no tag present or the tag does not respond the request.

#### 4.4.3.3.5 Unable to read after write 'X'

The tag was removed from field immediately after copy instruction.

Data was decremented but the tag did not respond to the read after copy instruction, which is done automatically by the reader module.

#### 4.4.3.4 Continuous Read

The reader device reads and displays serial numbers continuously while one or more tags remain in the field. This command stops if any character is sent to the reader module.

The reader supports different tag types at the same time. To increase the reading performance switch to a single tag mode. If more than one tag of the same tag type should be detected at the same time the Multitag flag must be activated. The response data length depends on the tag type.

##### Command

Command	Data
'c'	none

##### Answer

Answer	Description
data	serial number (n bytes)
'N'	Error: No Tag in the field (only binary protocol)

#### 4.4.3.4.1 Multitag continuous read mode

If the Multitag flag is set in the Protocol Configuration (PCON) register the reader reads multiple tags continuously.

#### 4.4.3.4.2 Auto start

The continuous read mode is started automatically. The auto start flag must be set in the PCON register.

#### 4.4.3.4.3 Binary mode

This command is not fully supported in binary protocol mode.

Continuous Read in binary mode does not startup automatically at boot time, even if the corresponding EEPROM flag is set.

Within the single shot timeout only one response is sent.

#### 4.4.3.4.4 Simple access control applications

Serial numbers are always sent plain. Data encryption is activated after a successful log in.

For simple access control applications it is recommended to use read-only blocks for the identification of the tag.

Reading any block (even the manufacturer block) of the transponder will increase your security.

#### 4.4.3.4.5 Extended ID

If Extended ID is activated a prefix byte extends the serial number. For more information refer to Protocol Configuration register.

#### 4.4.3.5 Get Station ID

This command returns the station ID of the reader device. The answer is time slotted to enable that all devices in party line mode are detected.

The station ID has only effect in binary mode.

##### Command

Command	Data
'g'	None

##### Answer

Answer	Description
Data	Station ID of the reader device (1 byte)

#### 4.4.3.5.1 Time slotted answer

In party line mode more than one reader can be used simultaneously. The time slotted answer allows separating all connected devices. The station ID is used to determine the correct time slot.

The reader supports up to 254 unique time slots. Following formula calculates the needed time of one time slot. Only one baud rate on the same party line is supported.

$$T_0[s] = \frac{10}{\text{Baudrate}} * 6$$

Figure 4-10: Time slot formula



Following figure shows the timing diagram of time slotted answers.

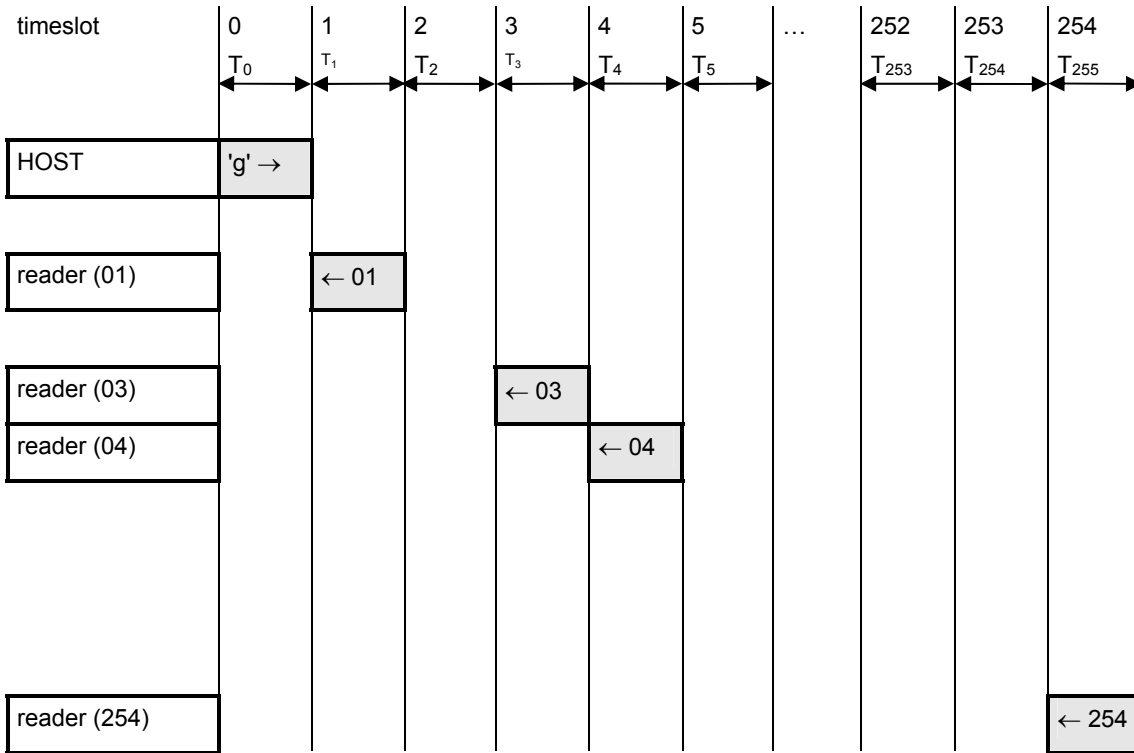

Figure 4-11: Timing diagram of time slotted answers

#### 4.4.3.6 Login (authenticate tag)

Performs an authentication to access one sector of a MIFARE® card. Only one sector can be accessed at the same time.

Optionally to transmit the key data to the reader stored keys, in the reader EEPROM, can be used.

To store keys in the EEPROM the write master key command is used. It is possible to store up to 32 master keys in the reader EEPROM. The login requires a successful select.

##### Command

Command	Data
'I'	Sector (1 byte) ), valid range 00h - 3Fh Key type (1 byte)  AAh authenticate with key type A FFh authenticate with key type A, transport key FFFFFFFFFFh BBh authenticate with key type B 10h ... 2Fh authenticate with key type A using stored key (00h ... 1Fh) 30h ... 4Fh authenticate with key type B using stored key (00h ... 1Fh)  Key (6 bytes) / <CR> (1 byte), optional By transmitting <CR> instead of the keydata authentication is done with manufacturers transport keys (A0A1A2A3A4A5h, B0B1B2B3B4B5h, FFFFFFFFFFh).

##### Answer

Answer	Description
data	Login status (1 byte)
'L'	Login success
'E'	Error: Invalid key format
'F'	Error: General failure
'N'	Error: No tag

##### Example

Command	Description
I02AA<CR>	Authenticate for sector 2, using the transport key A (A0A1A2A3A4A5h, key type A)
I3FBB<CR>	Authenticate for sector 63, using the transport key 2 (B0B1B2B3B4B5h, key type B)
I04FF<CR>	Authenticate for sector 4, using the transport key 3 (FFFFFFFFFh, key type A)
I0FAFFFFFFFFF	Authenticate for sector 15, using key FFFFFFFFFFh, key type A
I0E14	Authenticate for sector 14, using EEPROM key 4, key type A
I0530	Authenticate for sector 5, using EEPROM key 0, key type B
I0732	Authenticate for sector 7, using EEPROM key 2, key type B
I0110	Authenticate for sector 1, using EEPROM key 0, key type A
I0ABBFF12FFFFFF35	Authenticate for sector 10, using key FF12FFFFFF35h, key type B

#### 4.4.3.6.1 No tag error 'N'

The reader does not detect a response of the tag. There is either no tag present or the tag does not respond the request.

#### 4.4.3.6.2 <CR>

Three transport keys are implemented to access cards fast.

Transmitting <CR> instead of the key the reader module uses transport keys for the login procedure.

Command	Description
LxxAA<CR>	Authenticate for sector xx, using the transport key A (A0A1A2A3A4A5h, key type A)
LxxBB<CR>	Authenticate for sector xx, using the transport key 2 (B0B1B2B3B4B5h, key type B)
LxxFF<CR>	Authenticate for sector xx, using the transport key 3 (FFFFFFFFFFFFh, key type A)

#### 4.4.3.6.3 Login with keydata from EEPROM

Each key stored in the reader EEPROM can be used as keytype A or keytype B. To use a key as type A the value 10h must be added to the key index. 30h must be added to use a key as type B.

#### 4.4.3.6.4 Usage of key A, key B

MIFARE® cards support two different crypto keys for each sector. Each key is 32 bit long and is stored in the sector trailer (last block of the sector) on a card. It is possible to set different access rights for each key.

#### 4.4.3.7 Multi Tag Selection / List

This command detects several tags at the same time. It replaces the fast select command ('s') in multiple tag surroundings. The Multi Tag list command lists all tags with its serial numbers. Use the Multi Tag Select command to select a single tag. Each tag has to be selected separately.

##### Command

Command	Data
'm'	Serial number (n bytes) <CR> (1 byte)

##### Answer

Answer	Description
Data	serial number
'N'	Error: No Tag in the field

**Example**

Command	Description
m<CR>	04E9E700000000 → first card 34030F07 → second card 02 → number of detected tags
m04E9E700000000<CR>	Select card with its serial number

**4.4.3.7.1 Multi tag list**

Sending a <CR> as first parameter the reader returns a list of all present tags in the antenna field. In the end the amount of detected tags are returned.

**4.4.3.7.2 Reading distance**

Each card needs a specific amount of power. The reader always provides the same power. Therefore the reading distance will decrease if more tags are present. Basically, the reading distance depends on the used tag, antenna and its tuning.

**4.4.3.7.3 Multi tag select**

Using the serial number with <CR> as parameter the according tag will be selected. High-level interactions can be performed addressing only this card. All other tags remain silent.

**4.4.3.7.4 Multi tag reset**

The antenna field reset can be deactivated with Protocol configuration 2 register.

By suppressing the antenna field reset it is possible to detect only new tags in the antenna field.

**4.4.3.7.5 Maximum number of tags**

The maximum number of tags in the antenna field is limited to the physical characteristics of the antenna.

The implementation detects up to 16 tags.

**4.4.3.8 Antenna power on/off**

This command controls the antenna power. It can be used to decrease the power consumption of the reader.

**Command**

Command	Data
'pon'	Switch on reader
'poff'	Reader enters the stand by mode

**Answer**

Answer	Description
'P'	Positive acknowledge

**Example**

Command	Description
poff	Reader enters stand by mode

#### 4.4.3.8.1 Power off

The reader enters the stand by mode. Power consumption is decreased. All tags in the antenna field are powered off and reset. The stand by mode is only entered manually.

To switch off the whole unit pin 16 (Enable) has to be set to logic low.

#### 4.4.3.8.2 Power on

The reader leaves the stand by mode and is ready for the next command. Sending a tag command (for example select, continuous read) the reader is powered up.

#### 4.4.3.8.3 Reset Timing

The power up timing depends on environmental conditions such as voltage ramp up.

#### 4.4.3.9 Read/Write user port

This command sets or reads the state of the user port (pin 14) of the OEM reader device. The port is set either as output or as input.

##### Command

Command	Data
'pr'	none
'pw'	State of user port (1 Byte)

##### Answer

Answer	Description
Data	State of user port (1 Byte)

##### Example

Command	Description
pr	Reads user port
pw01	Sets user port state to high

#### 4.4.3.9.1 Read port

The port read command returns the current state of the USER port.

Port state	Description
00	USER port is low
01	USER port is high

Figure 4-12: Read USER port return values

#### 4.4.3.9.2 Write port

If user port is used as an output a 1k $\Omega$  resistor has to be integrated into the wire. Otherwise the reader device can be damaged.

Port state	Description
00	Sets USER port to low
01	Sets USER port to high

Figure 4-13: Write User port settings

#### 4.4.3.10 Read block

This command reads a data block on a card. Size of returned data depends on the used tag. The block address range depends on the present tag.

##### Command

Command	Data
'r'	Block address (1 byte), valid range 00h – 40h
'rb'	Block address (1 byte)

##### Answer

Answer	Description
Data	block data (depends on tag type)
'F'	Error: read failure
'N'	Error: No tag in field
'O'	Error: Operation mode failure

##### Example

Command	Description
rb05	Reads block 05.

##### 4.4.3.10.1 Read failure 'F'

This error is returned if the reader receives either bad data or the block address exceeds the block address range of the sector.

##### 4.4.3.10.2 No tag in field 'N'

The tag does not respond. There is either no tag present or not addressed.

##### 4.4.3.10.3 Operation mode failure 'O'

The block address of the 'r' command is higher than 40h.

The block address of the 'r' command conflicts with other commands, therefore the block address has to be limited to 40h.

Use the 'rb' command instead.

#### 4.4.3.11 Read reader EEPROM

This command reads the internal reader EEPROM. It contains all startup parameters and the device ID. Changes of the startup settings will only be taken into effect after a reset of the device.

##### Command

Command	Data
're'	EEPROM address (1 byte) 00h ... 13h

##### Answer

Answer	Description
Data	EEPROM data (1 byte)

##### Example

Command	Description
rp05	Reads protocol configuration register.

#### 4.4.3.12 Read value block

Reads a value block. The command checks if data is in value block format. The read value block command needs a successful login.

##### Command

Command	Data
'rv'	Value block (1 byte)

##### Answer

Answer	Description
Data	Read value (4 bytes)
'F'	Error: General failure
'I'	Error: value block failure
'N'	Error: No tag in field

##### Example

Command	Description
rv04	Reads value of block 4.

##### 4.4.3.12.1 No value block 'I'

The value read back after the write value instruction is a not a value block. Data was written corruptly.

##### 4.4.3.12.2 No tag error 'N'

This means that the tag does not respond, because there is either no tag present or none of the tags in the field is authenticated ('I' instruction).

##### 4.4.3.12.3 General failure 'F'

Additional to a data read error caused by bad transmission conditions, this error appears if a sector is addressed which is not located in the authenticated sector.

#### 4.4.3.13 Select

This command selects a single card in the antenna field. It can only be used in single tag mode. In the case of success the command returns the UID of the selected card. The reader detects the length of the card automatically.

##### Command

Command	Data
's'	None

##### Answer

Answer	Description
Data	serial number
'N'	Error: No Tag in the field

##### Example

Command	Description
s	1234567890ABCD Select the card with its UID 1234567890SABCD.

##### 4.4.3.13.1 Select a single tag

No previous continuous read is required. The command executes an automatic field reset.

##### 4.4.3.13.2 Extended ID

For more information of the Extended ID refer to Protocol configuration register.

##### 4.4.3.13.3 Multiple tags

This command is designed for fast access of a single tag in the field. If multiple cards are used the 'm' instruction has to be used instead.

##### 4.4.3.14 Get Version

This command returns the current version of the reader module.

##### Command

Command	Data
'v'	None

##### Answer

Answer	Description
'MIFARE 1.0' + <CR> + <LF>	ASCII Mode
02 00 0A 4D 69 66 61 72 65 20 31 2E 30 31 03	Binary Mode

##### Example

Command	Description
v	'MIFARE 1.0' Version of the reader module



#### 4.4.3.15 Write block

This command writes data to a block. A read after write is done automatically to ensure correct writing.

##### Command

Command	Data
'w'	Block address (1 byte), valid range 00h – 40h Data (n bytes)
'wb'	Block address (1 byte) Data (n bytes)

##### Answer

Answer	Description
Data	Block data (depends on tag type)
'F'	Error: Write failure
'N'	Error: No tag in field
'O'	Error: Operation mode failure

##### Example

Command	Description
wb0511223344	Writes data 11223344 on block 05.

##### 4.4.3.15.1 Write failure 'F'

This error is displayed if bad transmission conditions are given. If the block address exceeds the physical number of blocks of a tag this error is thrown.

##### 4.4.3.15.2 No tag error 'N'

This error is returned if no tag is present or the card does not respond.

##### 4.4.3.15.3 Operation mode failure 'O'

The block address of the 'w' command is higher than 40h.

The block address of the 'w' command conflicts with other commands, therefore the block address has to be limited to 40h.

Use the 'wb' command instead.

**4.4.3.16 Write EEPROM**

Writes to the internal reader EEPROM. It contains all startup parameters and the device ID. Changes of the startup settings will only be taken into effect after a reset of the device.

**Command**

Command	Data
'we'	Address (1 byte), valid range 04h - 13h Data (1 byte)

**Answer**

Answer	Description
Data	EEPROM data (1 byte)
'F'	Error: Read after write failure

**Example**

Command	Description
we0401	Set EEPROM address 04 (Station ID) to 01h

**4.4.3.17 Write master key**

This command stores a MIFARE® Standard key into the master key memory of the reader. The reader can store up to 32 keys.

**Command**

Command	Data
'wm'	Key number (1 byte) 00h ... 1Fh Key (6 bytes)

**Answer**

Answer	Description
data	written key (6 bytes)
'F'	Error: Write failure

**Example**

Command	Description
wm00112233445566	Store key 112233445566h in EEPROM (key number 0).
wm02A0A1A2A3A4A5	Store transport key 1 in EEPROM key 2.

#### 4.4.3.17.1 Writing master keys

Keys are write only. It is not possible to read the keys. Nevertheless the reader returns correct error messages if the writing process fails.

A verification of the master key can only be done using an appropriate card and a successful login.

#### 4.4.3.17.2 Using master keys for authentication

Master keys may be used for ISO-14443 A tag authentication. It is possible to use every stored for key A as well as key B authentication.

Each key is 6 bytes long and stored redundantly for data security.

#### 4.4.3.18 Write value block

This command formats a block as a value block containing a 32-bit value. A read after write is performed automatically. Value blocks need a complete 16-byte block due to redundant storage. A successful login is required to run the command.

##### Command

Command	Data
'wv'	Value block (1 byte) Value (4 bytes)

##### Answer

Answer	Description
Data	Written value (4 bytes)
'I'	Error: value block failure
'F'	Error: increment failure
'N'	Error: No tag in field
'U'	Error: Read after write failure

##### Example

Command	Description
wv05010055EF	Writes value 010055EFh to block 5.

#### 4.4.3.18.1 Invalid value 'I'

The value read back after the write value instruction is a not a value block. Data was written corruptly.

#### 4.4.3.18.2 Write failure 'F'

Additional to a data read error caused by bad transmission conditions; this error appears if a sector is addressed which is not located in the authenticated sector.

#### 4.4.3.18.3 No tag error 'N'

This error is returned if no tag is present or the card does not respond.

#### 4.4.3.18.4 Writing values

The write value block command is designed to create blocks, which match the value format. This command requires write access to specified block. It is not recommended to use this instruction for ticketing operations. For ticketing applications special instructions (Increment/Decrement/Copy) are supported.

#### 4.4.3.19 Reset

This command executes a power on (software) reset. New configuration settings will be loaded. It resets all tags in the antenna field.

##### Command

Command	Data
'x'	None

##### Answer

Answer	Description
'MIFARE 1.0' + <CR> + <LF>	ASCII Mode
None	Binary Mode

#### 4.4.3.19.1 Reset Timing

The power up timing depends on environmental conditions such as voltage ramp up. For handheld devices the timing can change on the charging state of the battery.

## 5 Frequently Asked Questions

---

### 5.1 Getting Started

To test and interface the MIFARE Easy Module, you do not need a sophisticated  $\mu$ P development system. All you need is a PC, a connection cable and a power supply for the reader. If you are using Microsoft Windows (95/98/NT/...), take the following steps:

- Make sure, that your reader is RS232-interface type
- Start HyperTerminal
- Create a new connection (FILE/NEW CONNECTION)
- Enter name of connection as you like (for example 'MIFARE')
- Select connect COM2 (COM1) direct connection
- Connection setup 9600,8,n,1,no handshake
- Connect your reader to COM2 (COM1) of the PC and apply appropriate the supply voltage. The reader transmits a string ("MIFARE 1.0") to the PC.
- This String denotes the firmware provided by your reader module
- Put a tag to your reader. Serial numbers should be displayed properly
- Enter commands via keyboard. They should be transmitted to the reader and the reader should reply

If using an operating system different from Microsoft Windows you may use any other terminal program which is capable of receiving/transmitting data via the serial port of your PC.

### 5.2 How should the MIFARE® Easy Reader be personalized?

In ASCII protocol applications, no personalization is necessary.

In applications that are using the binary protocol mode a personalization procedure is required. Use the Utility program to set up your reader correctly. Ask the reseller or the sales representative of the reader for the Utility software or download software from [www.hidcorp.com/Omnikey](http://www.hidcorp.com/Omnikey). System requirements are WIN98SE (at a minimum,) and a computer COM port.

### 5.3 What type of MIFARE® card should I use?

MIFARE® Standard is designed for multi application environment. It contains 16 sectors each with 2 individual keys, access conditions, 3 data or value blocks. Some applications use the 1 Kbytes of the MIFARE® Standard Card Memory just as storage.

MIFARE® Ultralight has not a crypto unit on chip. It only supports 16 blocks.

MIFARE® Standard 4k cards have the same features as MIFARE® Standard card but increased memory capacity.

## 5.4 How safe is MIFARE® Standard for cashless payment?

Security is always a property of the overall system, not of the components. It requires careful design.

A properly designed system will require **ALL** barriers to be hacked in order to be broken.

For good design start specifying feasible attacks. Then create barriers to block them.

MIFARE® was specifically designed for cashless payment applications. The MIFARE® concept provides following barriers:

- Anti-collision/-selection
- Atomic value transaction
- Ciphared communication
- Storage of values and data protected by mutual authentication
- Weak field keys that allow decrement only
- Stored keys in the reader that are not readable
- Keys in the card that are not readable
- A brute force attack by trying different keys is limited by the transaction time (several msec) of the card and would last virtually forever.
- etc.

The Application can and should provide more barriers:

- Sector access conditions. It is possible to assign access conditions in a way that only decrementing of values is allowed with the keys used in the field. So even a manipulated field station cannot be used to charge cards with additional values. As a rule, key A is used as a field key, allowing decrement and read only, and key B to format the card or charge values.
- Diversified keys. To make life even harder for attackers, keys can be modified using serial number and memory content of the card. So each card uses different keys and a listening attack on the reader interface would be hopeless.
- Limiting cash volume stored on a card
- Do not use the transport keys (keys as programmed after delivery) for ticketing applications!
- Ciphared and scrambled data storage
- Sabotage alarm
- etc.
- Even higher security with contactless controller cards like DESFire, MIFARE® ProX, MIFARE® Smart MX etc.

## 5.5 MIFARE® Standard Sector Trailer and Access Conditions

The last block of each sector contains configuration data for the sector. This configuration data includes key A, key B and the access conditions. The first six byte (byte 0...5) of the Sector Trailer contain key A data, the last six bytes (byte 10...15) contain key B data.

Byte number 6 to byte number 9 contain the access conditions for each block of the sector. It is possible to configure the access rights (read, write, increment, decrement, restore) different for each block in the sector and in dependence to the key used in the authentication (login) procedure.

Access conditions for the Sector Trailer himself are different from access conditions of a data block (increment, decrement, copy is never allowed for the Sector Trailer as of course this block never contains value data). The access conditions are stored redundant for data security reasons.

Please consider that enabled keys are not readable and therefore return 00 on reading.

It is possible to configure each block of one sector as Value Block (Ticketing) or Data Block.

As an example you may use the following values for the access rights:

Block 0	Block 1	Block 2	Sector Trailer
V	V	V	08 77 8F FF
V	V	D	48 77 8B FF
V	D	V	28 77 8D FF
V	D	D	68 77 89 FF
D	V	V	18 77 8E FF
D	V	D	58 77 8A FF
D	D	V	38 77 8C FF
D	D	D	78 77 88 FF

Where “D” denotes a data block and “V” value block. All access conditions are configured that way that key B has write access to the Sector Trailer and so may change the configuration.

Each of the 16 sectors consists of 4 blocks (including the sector trailer). Block 0 of sector 0 contains the serial number and some manufacturer data. It is read only.

For detailed description of the Sector Trailer /Access Conditions please refer to the datasheets of your chip manufacturer. As it is possible to destroy the tag (permanently make a block read and write protected) it is strongly recommended not to change the Sector Trailer without detailed knowledge and under safe environment with good reading/writing only.

### 5.5.1 Examples

#### 5.5.1.1 Ticketing Applications

For ticketing applications it is recommended to use both keys of the MIFARE® card. Key A as a field key with rights for read, copy and decrement only. Key B is used as master key with full access rights (including increment and changing the access conditions and keys).

#### 5.5.1.2 Data Handling Applications

For data handling Applications it is recommended to disable ticketing operations (increment, decrement, copy). Key A is user as slave key with reading rights only. Key B is used as master key with read/write access to all blocks.

### 5.5.1.3 No Security, open configuration

For open configuration applications it always possible not to change the sector trailer (FF 07 80 xx) and use the configuration as defined by the card manufacturer.

Key A is set as master key with full access rights and key B is disabled.

## 5.6 Using a MIFARE® card

This example demonstrates detecting a card in the antenna field with continuous read and additional reading of a page.

Command	Answer
c	Activate continuous read mode
	B2197B58 a card responses with his serial number
.	S abort continuous read mode
s	B2197B58 select card
I01AFFFFFFFFFFFFFFF	L login into sector 1 with key FFFFFFFFFFFFFFh key type A
rb04	00112233445566778899AABBCCDDEEFF read block 04
c	Activate continuous read mode to detect a new card

Figure 5-1: Using a MIFARE® card

## 5.7 Using NFC

The example shows how to communicate with NFC using the NFC demo board PN531.

The reader is the initiator. The NFC has to be configured as passive target using MIFARE® 106kbps (other NFC modes are not supported).

As first step place the reader on top of the NFC demo board antenna in 3 cm distance.

Then load the "passive\_target\_106.cmd" file from the "Scripts\Tama\P2P" subfolder into the SCRTTester application. Run the code.

Now it is possible to get a serial number from the NFC:

Command	Answer
s	08123456

Figure 5-2: Get a serial number from NFC



---

## References

---

- [1] ISO/IEC 14443 Part 1-4, Identification Cards – Contactless integrated circuit(s) cards – Proximity cards
- [2] DESFire Documentation, Philips, <http://www.semiconductors.philips.com>
- [3] Antenna Design Guide
- [4] Philips; Application Note, MIFARE® & I-Code, Micore Reader IC family Directly Matched Antenna Design

# Appendix A: Compact P&P Module

## Dimensions

All dimensions in mm

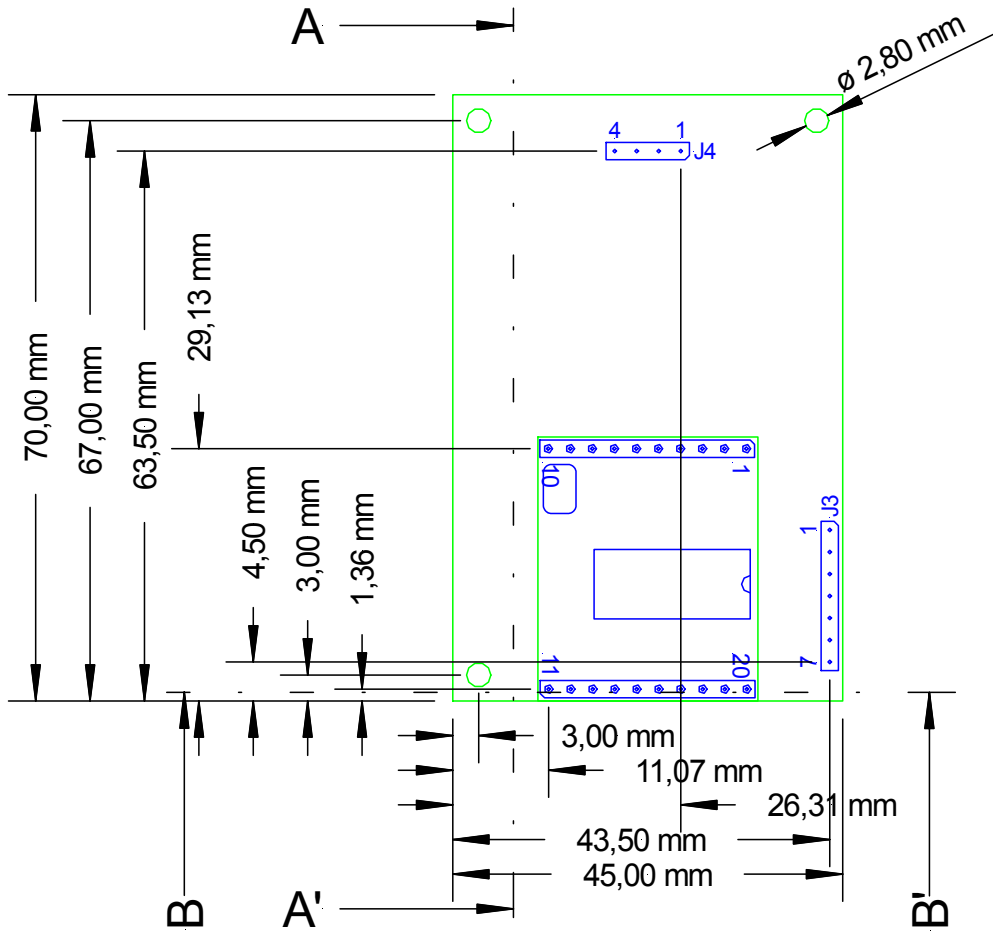

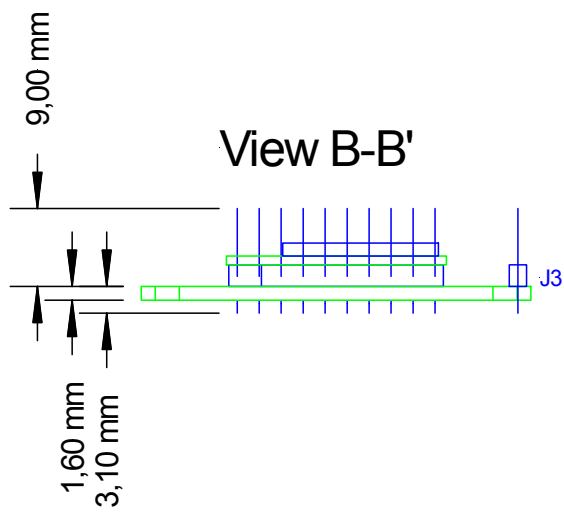
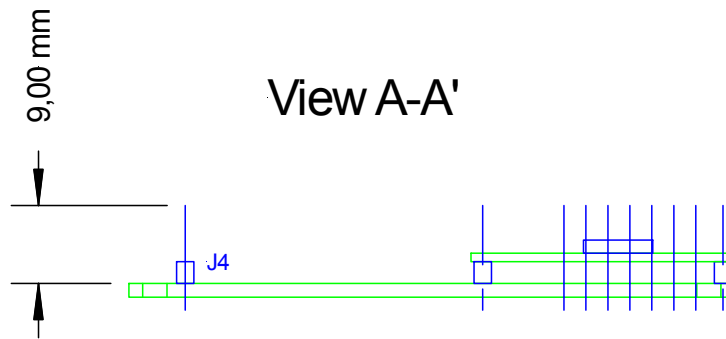

## Pin Out

### Pin Out of J3

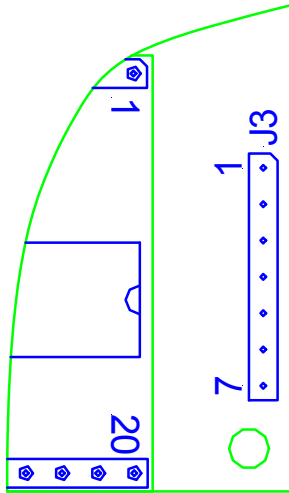

PIN	PIN No.	Description
RFU	1	RFU
VDD	2	Supply Voltage
GND	3	Ground
RX/RXA	4	RS232 RX / RS422 RXA
TX/TXA	5	RS232 TX / RS422 TXA
RXB	6	RS422 RXB
TXB	7	RS422 TXB

**Electrical characteristics of J3 PINs in RS232 Configuration**

PIN	PIN No.	Min	Typ.	Max.	Description
RFU	1				Do not connect
VDD	2	4.5V	5V	5.5V	Supply Voltage
			150mA	250mA	Supply Current (without SAM)
GND	3		GND		Ground for Power Supply and Interface
RX/RXA	4	-15V 3kΩ	5kΩ	+15V 7kΩ	RS232 Voltage Levels Input Impedance
TX/TXA	5	±5V 300kΩ	±9V		RS232 Voltage Levels Output Impedance
RXB	6				Do not connect
TXB	7				Do not connect

**Pin out of jumper 3 in RS232 Configuration**

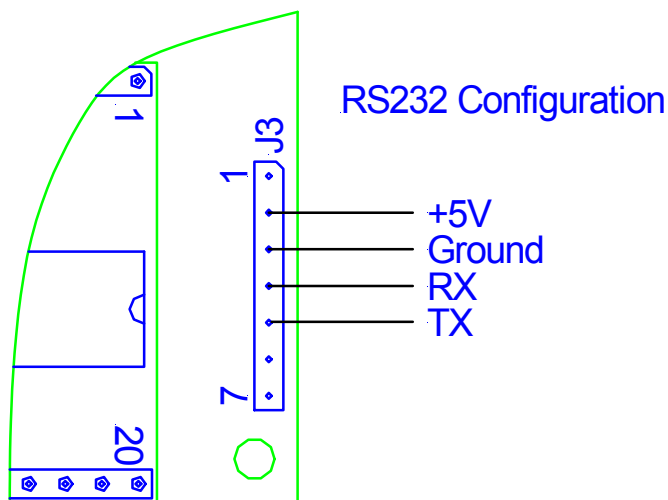

**Pin Out of J4 (Top View)**

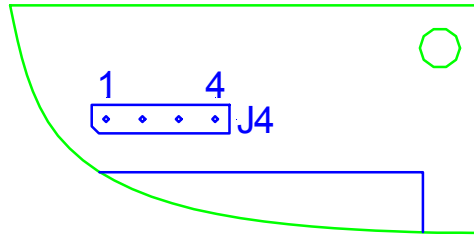

PIN	PIN No.	Description
Read+	1	Connector for green Read Indicator LED
Read-	2	Connector for red Read Error Indicator LED
Power-	3	Ground
Power+	4	Connector for Power Indicator LED

**Electrical characteristics of J4 PINS**

PIN	PIN No.	Min	Typ.	Max.	Description
Read+	1		1.4V @11mA	VDD <sub>max</sub>	
			11mA	@15mA	
Read-	2		1.4V @11mA	VDD <sub>max</sub>	
			11mA	@15mA	
Power-	3		GND		
Power+	4		1.4V @11mA	VDD <sub>max</sub>	
			11mA	15mA	

**Pin out of J4**

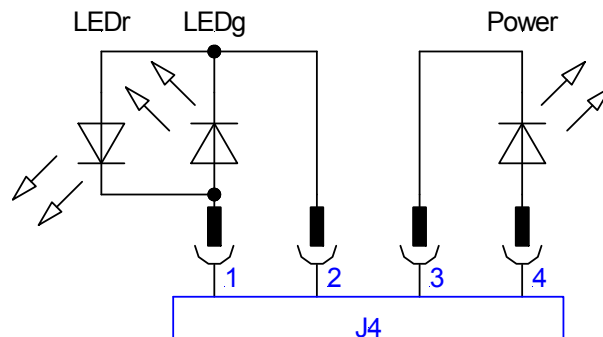

## Appendix B: Short Range P&P Module

### Dimensions

All dimensions are listed in mm.

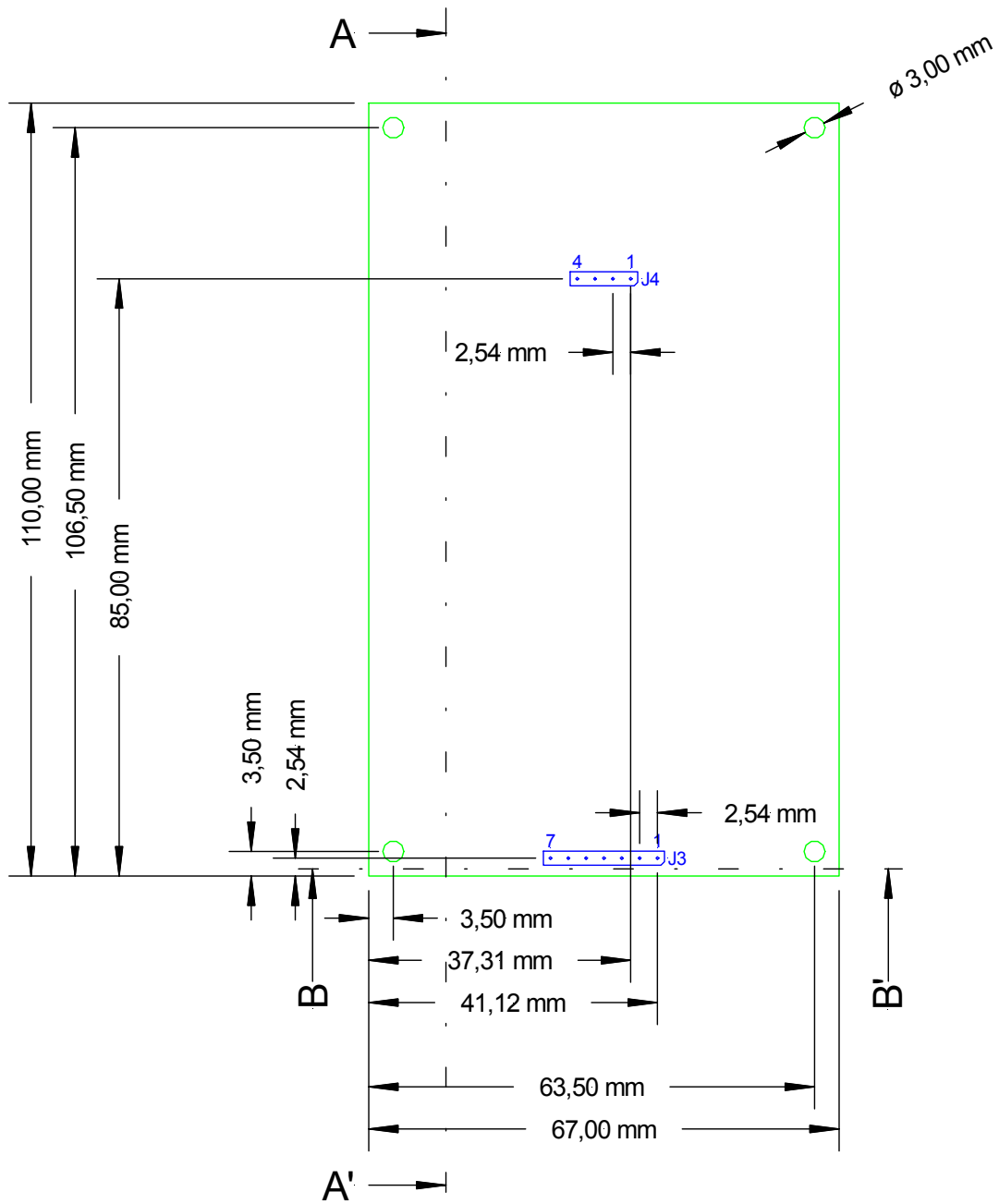

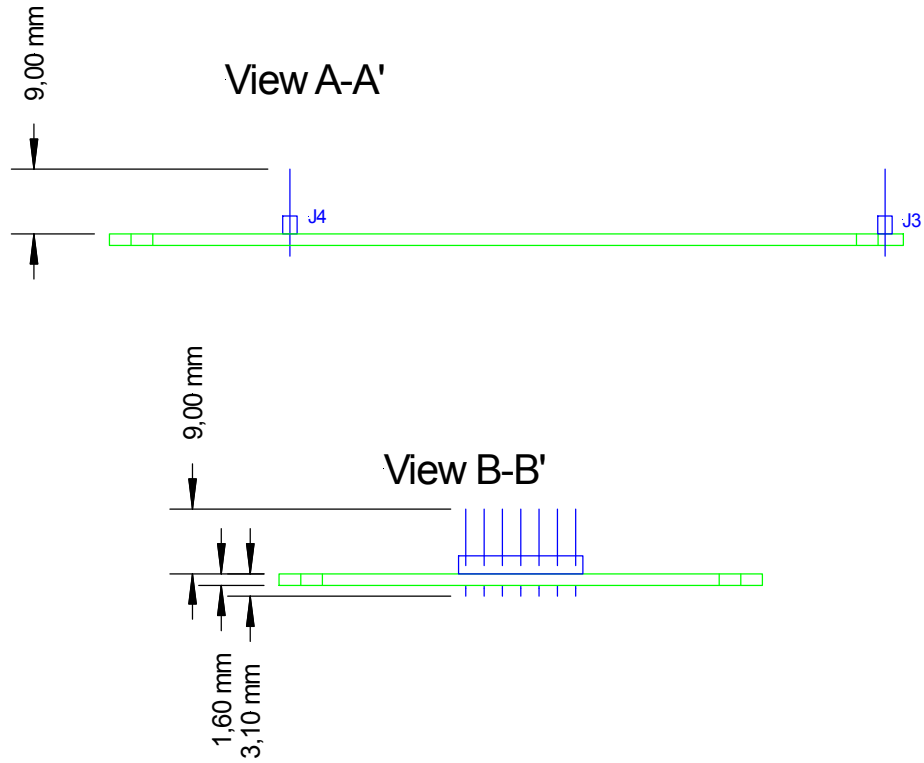

## Pin Out

### Pin Out of J3

PIN	PIN No.	Description
RFU	1	RFU
VDD	2	Supply Voltage
GND	3	Ground
RX/RXA	4	RS232 RX / RS422 RXA
TX/TXA	5	RS232 TX / RS422 TXA
RXB	6	RS422 RXB
TXB	7	RS422 TXB



**Electrical characteristics of J3 PINs in RS232 Configuration**

PIN	PIN No.	Min	Typ.	Max.	Description
RFU	1				Do not connect
VDD	2	4.5V	5V	5.5V	Supply Voltage
			150mA	250mA	Supply Current (without SAM)
GND	3		GND		Ground for Power Supply and Interface
RX/RXA	4	-15V 3kΩ	5kΩ	+15V 7kΩ	RS232 Voltage Levels Input Impedance
TX/TXA	5	±5V 300kΩ	±9V		RS232 Voltage Levels Output Impedance
RXB	6				Do not connect
TXB	7				Do not connect

**Pin Out of J4 (Top View)**

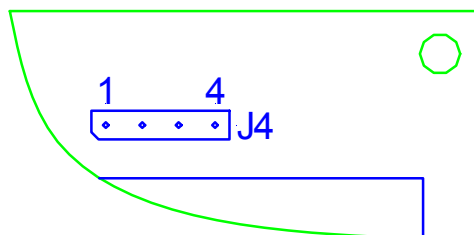

PIN	PIN No.	Description
Read+	1	Connector for green Read Indicator LED
Read-	2	Connector for red Read Error Indicator LED
Power-	3	Ground
Power+	4	Connector for Power Indicator LED

**Electrical characteristics of J4 PINs**

PIN	PIN No.	Min	Typ.	Max.	Description
Read+	1		1.4V @11mA	VDD <sub>max</sub>	
			11mA	@15mA	
Read-	2		1.4V @11mA	VDD <sub>max</sub>	
			11mA	@15mA	
Power-	3		GND		
Power+	4		1.4V @11mA	VDD <sub>max</sub>	
			11mA	15mA	

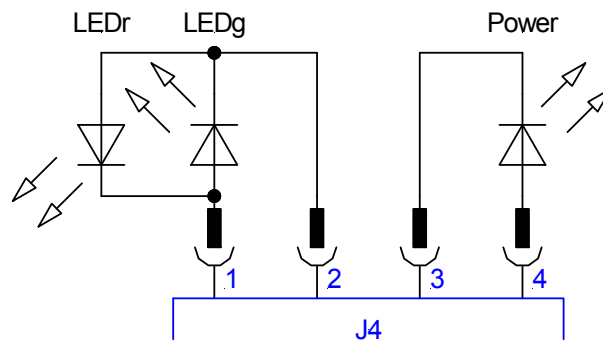

## Appendix C: Timings

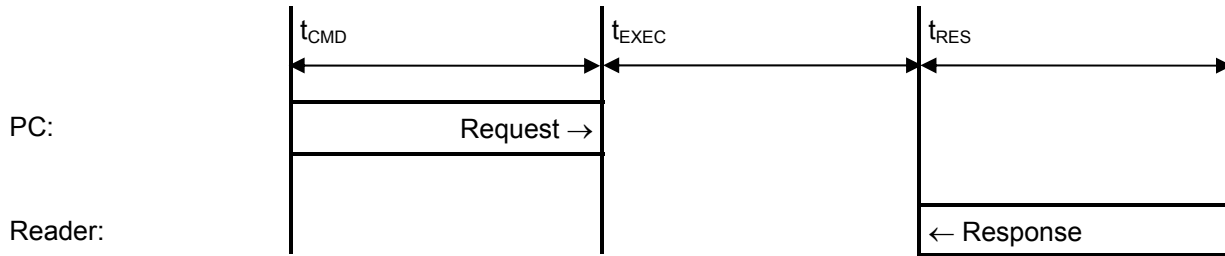

Command	$t_{EXEC}$ [ms]	Comments
<b>Common commands</b>		
cont. read	7	+ Reset Off and Recovery Time
multi-select	10	+ Reset Off and Recovery Time
multi-select (no tag)	35.4	+ Reset Off and Recovery Time
antenna on	0.5	
antenna off	0.6	
port read	0.3	
port write	0.3	
read block	4.1	
write block	11.6	
reset	107	
select	8.8	+ Reset Off and Recovery Time
select (no tag)	35.4	+ Reset Off and Recovery Time
increment value block	15.1	
decrement value block	15.1	
copy value block	15	
read value block	4	
write value block	15.5	
<b>Power conditions</b>		
Power on	145	excluded raising time of power supply
Enable on	114	

All timing data is advisory application information and does not form part of the specification. It may change in further firmware releases. Please note also that all in the above table specified values depend on the used tag.

## Appendix D: Version History

---

### Revision History

Date	Revision number
10/27/08	Version 1.0, Rev. 2.0 HID Format
10/07/2005	Version 1.0, Rev. 1.1
04/13/2005	Version 1.0, Rev. 1.0

### **MIFARE 1.0**

Initial Release.

---

## Appendix E: Approvals / Certificates

---

### CE Declaration

**HID Global** declares that, in conformity with the European CE requirements specified in the EMC Directive 89/336/EEC, the MIFARE Easy Plug & Play Read/Write Module, described in this manual is

***CE compliant***

The relevant documents are available.

If any of the HF MIFARE Easy Plug & Play Read/Write Module is operated from a mains power supply, all power connections and additional components of the final device must also comply with the EMC Directive 89/336/EEC directive.

Customers selling into Europe must themselves make sure that the final device conforms to the EMC Directive 89/336/EEC directive.

For HID Global, the compliance of important international regulations into business practices are a priority and the implementation of the EMC Directive 89/336/EEC is fully in line with the company's commitment to continuously improve its Quality Management System.

## FCC Declaration

**HID Global** declares that, in conformity with the U.S. Directive FCC part 15, the HF MIFARE Easy Plug & Play Read/Write Module, described in this manual, is

# ***FCC part 15 compliant***

The relevant documents are available.

If any of the HF MIFARE Easy Plug & Play Read/Write Module is operated from a mains power supply, all power connections and additional components of the final device must also comply with the US FCC Part 15 directive.

Customers selling into the USA must themselves make sure that the final device conforms to the US FCC Part 15 directive.

**Caution:** Any changes or modifications not expressly approved by the party responsible for compliance could void the user's authority to operate the equipment.

For HID Global, the compliance of important international regulations into business practices are a priority and the implementation of the FCC part 15 is fully in line with the company's commitment to continuously improve its Quality Management System.

## RoHS Compliance

**HID Global** declares that, in conformity with the Directive 2002/95/EC about the Restriction of Hazardous Substances (RoHS), its HF MIFARE Easy RFID Reader products, listed in this manual, are

# *RoHS compliant*

The following substances are contained in accordance with the limits required by the Directive.

- Cadmium and cadmium compounds
- Lead and lead compounds
- Mercury and mercury compounds
- Hexavalent chromium compounds
- Polybrominated biphenyls (PBB)
- Polybrominated Diphenyl Ethers (BPDE)

For HID Global, the integration of environmental considerations into business practices are a priority and the implementation of RoHS Directive is fully in line with the company's commitment to continuously improve its Quality Management System.