



Hirden AC Servo Drive for Industrial Control Application

H3L10-N Series User Manual (First Version)

Ningbo Hirden Industrial Control System Co.,Ltd

Thank you very much for purchasing Hirden's AC servo products.

This manual will be helpful in the installation, wiring, inspection and operation of Hirden AC servo drive. Before using the product, please read this user manual to ensure correct use.

Contents of this manual

This manual is a user guide that provides the information on how to operate and maintain H series AC servo drives. The contents of this manual are including the following topics:

- Installation of AC servo drives
- Configuration and wiring
- Parameter settings
- Control functions and adjusting methods of AC servo drives
- Trial run steps
- Troubleshooting

Who should use this manual

This user manual is intended for the following users:

- Those who are responsible for installing or wiring.
- Those who are responsible for operating or programming.
- Those who are responsible for troubleshooting.

Important precautions

Before using the product, please read this user manual thoroughly to ensure correct use and store this manual in a safe and handy place for quick reference whenever to be necessary. Besides, please observe the following precautions:

- Do not use the product in a potentially explosive environment.
- Install the product in a clean and dry location free from corrosive and inflammable gases or liquids
- Ensure that the drive is correctly connected to a ground. The grounding method must comply with the electrical standard of the country.
- Do not connect a commercial power supply to the U, V, W terminals of drives, otherwise the drive will be damaged.
- Do not attach, modify and remove wiring when power is applied to the AC servo drive.
- Do not disconnect the drive and motor when the power is ON.
- Do not touch the heat sink of the drive during operation.

If you do not understand, please contact your local Hirden sales representative. Please place this user manual in a safe location for future reference.

Safety Caution

Installation

◆The applications should be kept away from the water vapor,corrosive gases,flammable gases and so on.Otherwise it may result in electric shock,fire or personal injury.



◆The application environment should be without direct sunlight,dust,salt and metal powder,and so on.

◆The applications should be kept away from the place which the oil and pharmaceutical will attach or be dipped.

Wiring

◆Connect the ground terminals to a class-3 ground (Ground resistance should not exceed 100 Ω)

◆The H series AC servo drive is suitable for AC 220V single-phase or three-phase power.Please do not connect to the power AC 380V.Failure to observe this precaution may damage the drive.



◆Do not connect any power supplies to the U,V,W terminals.Failure to observe this caution may result in injury,damage to the drive or fire.

◆Ensure that all screws,wire terminations and connectors are secure on the power supply,servo drive and motor.Failure to observe this precaution may result in damage,fire or personal injury.

◆In order to prevent fire hazard and accidents,please form the wiring by the cable specifications outlined in this manual.

Operation

◆ Before starting the operation with a mechanical system connected, change the drive parameters to match the user-defined parameters of the mechanical system. Starting the operation without matching the correct parameters may result in servo drive or motor damage, or damage to the mechanical system.

◆ Do not touch or approach any rotating parts (e.g. heatsink) while the servo is running. Failure to observe this caution may cause serious personal injury.



◆ Do not remove the operation panel while the drive is connected to an electrical power source otherwise electrical shock may result.

◆ Do not disassemble the servo drive as electrical shock may result.

◆ Do not connect or disconnect wires or connectors while power is applied to the drive.

◆ Wait at least 10 minutes after power has been removed before touching any drive or motor terminals or performing any wiring or inspection as an electrical charge may still remain in the servo drive.

1.Code list of the H series AC Servo for adaptive motor

Code	Motor Model	Power (Kw)	Torque (N.m)	Rated speed (rpm)	Rated current (A)
22	60ST-M00630	0.2	0.64	3000	1.2
23	60ST-M01330	0.4	1.27	3000	2.8
24	60ST-M01930	0.6	1.91	3000	3.7
25	80ST-M01330	0.4	1.3	3000	2.6
26	80ST-M02430	0.75	2.4	3000	4.2
27	80ST-M03330	1	3.3	3000	4.2
30	MG80ST-M04025	1	4	2500	4.4
31	MG90ST-M02430	0.75	2.4	3000	3
32	MG90ST-M03520	0.75	3.5	2000	3
33	MG90ST-M04025	1	4	2500	4
34	110ST-M02030	0.6	2	3000	4
35	110ST-M04030	1.2	4	3000	5
36	110ST-M05030	1.5	5	3000	6
37	110ST-M06020	1.2	6	2000	6
38	110ST-M06030	1.8	6	3000	8
44	130ST-M04025	1.0	4	2500	4
45	130ST-M05025	1.3	5	2500	5
46	130ST-M06025	1.5	6	2500	6
47	130ST-M07720	1.6	7.7	2000	6
48	130ST-M07730	2.4	7.7	3000	9
49	130ST-M10015	1.5	10	1500	6
50	130ST-M10025	2.6	10	2500	10
51	130ST-M15015	2.3	15	1500	9.5
52	130ST-M12020	2.4	12	2000	10
Others	110ST-M04030	1.2	4	3000	5

NOTE:

1. The parameter for moter code is PA1.The default motor code is set for 110ST-M04030 by 35. If you need to change the motor code PA1,you should set PA0 to 302 firstly.Secondly set PA1 to the code for the motor which you use according to the list. At last you need to save the parameters that you change.(You can read the chapter 4 to know how to save the parameters).The parameter PA1 will take effect by restart.
2. Code 22, 23 and 24 are applied to Hirden 60ST series motor only. If your motor is not produced by Hirden,please refer to chapter 3.
3. There are two types of the rotate direction for the encoder of the servo motor.The default type of Hirden servo drive and motor is same as the Delta's.Please makesure the type of the rotate direction for your motor, or contact your local Hirden sales representative.

2.Parameters List

No.	Function Description	Applicable Mode	Range	Default	Unit
PA-0	Password	ALL	0-1000	315*	
PA-1	Motor Code	ALL	0~100	35	
PA-2	Version	ALL	0~999	*	
PA-3	Monitor Status	ALL	0~19	0	
PA-4	Control Mode	ALL	0~5	0	
PA-5	Proportional Speed Loop Gain	P, S	5~2000	165*	Hz
PA-6	Speed Integral Time	P, S	1~1000	30*	ms
PA-7	Low-pass Filter for Torque	ALL	1~1000	10	0.1ms
PA-8	Speed Detection Filter	ALL	1~1000	10	0.1ms
PA-9	Proportional Position Loop Gain	P	1~1000	50	Hz
PA-10	Position Feed Forward Gain	P	0~100	0	%
PA-11	Smooth Constant of PA10	P	1~1000	0	ms
PA-12	Electronic Gear Ratio (Numerator) N1	P	1~32767	1	
PA-13	Electronic Gear Ratio (Denominator) M1	P	1~32767	1	
PA-14	External Pulse Input Type	P	0~2	1	
PA-15	Direction of External Pulse	P	0~1	0	
PA-16	Positioning Completed Width	P	0~30000	20	Pluse
PA-17	Excessive Position Error Range	P	0~30000	400	×100 Pluse
PA-18	Excessive Position Error Function Selection	P	0~1	0	
PA-19	Smooth Constant of Position Command	P	0~30000	0	0.1mS
PA-20	Inhibit Drive Function Selection	ALL	0~1	1	
PA-21	JOG Operation Speed	S	-3000~3000	120	r/min
PA-22	Speed Command selection	S	0~1	1	
PA-23	Alarm Enabled Statu Setting	ALL	0~1000	200	
PA-24	1st Speed Command	S	-3000~3000	0	r/min
PA-25	2nd Speed Command	S	-3000~3000	100	r/min
PA-26	3rd Speed Command	S	-3000~3000	300	r/min
PA-27	4th Speed Command	S	-3000~3000	-100	r/min
PA-28	Target Motor Speed	S	0~3000	500	r/min
PA-29	Analog Torque Command Gain	T	10~100	50	0.1V/100%
PA-30	Reserved			167	
PA-31	Pulse Logic Function Selection	P	1~5000	167	
PA-32	Reserved			167	
PA-33	Direction of Torque Command	T	0~1	0	
PA-34	Internal CCW Torque Command Limit	ALL	0~200	200*	%
PA-35	Internal CW Torque Command Limit	ALL	-200~0	-200*	%
PA-36	External CCW Torque Command Limit	ALL	0~200	100	%
PA-37	External CW Torque Command Limit	S	-200~0	-100	%

PA-38	Torque Command Limit for JOG and Trial Run	JOG, Sr	0~300	100	%
PA-39	Zero-offset Compensation for Torque Command	S	-2000~2000	0	
PA-40	Acceleration Time	S	1~10000	0	mS
PA-41	Deceleration Time	S	1~10000	0	mS
PA-42	Accel/Decel S-curve	S	1~1000	0	mS
PA-43	Analog Speed Command Gain	S	10~3000	300	(r/min)/V
PA-44	Direction of Speed Command	S	0~1	0	
PA-45	Zero-offset Compensation for Analog Speed Command	S	-5000~5000	0	
PA-46	Low-pass Filter for Speed Command	S	0~1000	3	mS
PA-47	On Delay Time of Electromagnetic Brake when motor is stopped	ALL	0~200	0	×10mS
PA-48	Off Delay Time of Electromagnetic Brake when motor is running	ALL	0~200	50	×10mS
PA-49	Target Speed for Opening Electromagnetic Brake	ALL	0~3000	100	r/min
PA-50	Sampling Gain for Bus Voltage	ALL	0~1000	506	
PA-51	Dynamic Electronic Gear Function Selection	P	0~1	0	
PA-52	Electronic Gear Ratio (Numerator) N2	P	1~32767	1	
PA-53	Digital Input Terminals Function Selection / Enabled Word 1	ALL	0000~1111	0	
PA-54	Digital Input Terminals Function Selection / Enabled Word 2	ALL	0000~1111	0	
PA-55	Current Sampling Gain	ALL	0~1000	312	
PA-56	Reserved	ALL		0	
PA-57	Reserved	ALL	0~255	0	
PA-58	Input Terminal Delay Time	ALL	1~1000	2	mS

3. Fault Messages Table

Display	Fault Name	Fault Description
Err - -	Normal	
Err 1	Overspeed	Motor's control speed exceeds the limit of normal speed.
Err 2	Overvoltage	Max circuit voltage exceeds its maximum allowable value.
Err 3	Undervoltage	Max circuit voltage is below its minimum specified value.
Err 4	Excessive position deviation	Position control deviation value exceeds the limit of its allowable setting value.

Err 6	Speed loop amplifier saturation	The amplifier of the speed control loop is saturated for a long time, which has exceeded the specified value.
Err 7	Limit switch error	Forward or Reverse limit switch is activated
Err 8	Position counter overflow	Position counter overflow occurs.
Err 9	Encoder error	Pulse signal is in error.
Err 10	Power voltage is overhigh	Excessive voltage is applied to the input
Err 11	Current response fault	Current error has exceeded the specified value for a long time.
Err 12	Short circuit	Main circuit current is higher than 1.5 multiple of drive's instantaneous maximum current value.
Err 13	Drive temperature error	The temperature of drive is over high.
Err 14	Regeneration error	Regeneration control operation is in error.
Err 16	Instantaneous overload	The instantaneous current of the drive is overhigh.
Err 17	Speed response fault	Speed error has exceeded the specified value for a long time.
Err 19	Warm reset	Software warm global reset
Err 20	EE-PROM error	An error occurs when writing the current settings into EE-PROM.
Err 23	Current sensor adjustment error	Adjusted value of the current sensor exceeds the limit of its allowable setting value when perform electrical adjustment.
Err 29	Overload for motor	Servo motor is overload.
Err 30	Pulse Z error	The pulse Z of the encoder is lost.
Err 32	U,V,W error	The wiring connections of U,V,W (for encoder interface) are in error
Err 34	OT	The ambient temperature is over high.
Err 35	UT	The ambient temperature is ultralow.
Err 36	Over current	The main circuit current of the drive is higher than 2 multiple of the rated current.
Err 37	Instantaneous overload for motor	The instantaneous load of the motor is heavier than 1.5 multiple of motor's maximum load value..
Err 38	Motor temperature error	The motor is overload for a long time.
Err 5,15,21,22,25,26,27,28,31,33		Reserved

Note: When the fault occurs, please refer to chapter 7.2 or contact your local Hirден sales representative.

Contents

CHAPTER 1 MODEL EXPLANATION	1
1.1 NAMEPLAT INFORMATION.....	1
1.2 SERIAL NUMBER EXPLANATION.....	1
1.3 MODEL NAME EXPLANATION	2
1.4 PRODUCT PART NAMES.....	2
1.5 SERVO DRIVE SPECIFICATION.....	3
CHAPTER 2 INSTALLATION AND STORAGE.....	5
2.1 UNPACKING CHECK.....	5
2.2 MACHINE DIMENSION.....	6
2.3 INSTALLATION ENVIRONMENT	6
2.4 INSTALLATION PROCEDURE AND MINIMUM CLEARANCES.....	7
2.5 STORAGE CONDITIONS	8
CHAPTER 3 WIRING.....	9
3.1 CONNECTORS AND TERMINALS	9
3.2 ENCODER CONNECTOR CN1	11
3.2.1 The Layout and View of CN1.....	11
3.2.2 Signal Identification for CN1	12
3.3 I/O INTERFACE CONNECTOR CN2	12
3.3.1 The Layout and View of CN2.....	12
3.3.2 Signals Explanation of Connector CN2.....	13
3.4 I/O INTERFACE TYPE.....	16
3.4.1 Digital signal input interface.....	16
3.4.2 Digital signal output interface	16
3.4.3 Position pulse input interface	17
3.4.4 Analog signal input interface.....	18
3.4.5 Encoder signal output interface.....	19
3.4.6 Encoder Open-collector Z-pulse output interface.....	19
3.4.7 Encoder feedback signal input interface.....	20
3.5 STANDARD CONNECTION EXAMPLE	21
3.5.1 Position control mode	21
3.5.2 Speed control mode.....	22
3.5.3 Torque control mode	23
CHAPTER 4 DISPLAY AND OPERATION	24
4.1 DESCRIPTION OF THE DIGITAL KEYPAD.....	24
4.2 MAIN MENU.....	25
4.3 MONITOR DISPLAY (DP--)	25

4.4 PARAMETER SETTING (PA--)	26
4.5 PARAMETER MANAGEMENT (EE--)	27
4.6 SPEED TRIAL RUN WITHOUT LOAD (SR--)	28
4.7 JOG TRIAL RUN WITHOUT LOAD (JR--)	28
4.8 ZERO-OFFSET ADJUSTMENT	28
CHAPTER 5 TRIAL RUN AND TUNING PROCEDURE	30
5.1 INSPECTION WITHOUT LOAD	30
5.1.1 Applying power to the drive	31
5.1.2 JOG trial run without load	31
5.1.3 Speed trial run without load	32
5.2 POSITION CONTROL MODE	33
5.2.1 Simple position control system	33
5.2.2 Parameters for the position control	35
5.2.3 Electronic gear ratio	36
5.2.4 Position proportional gain	38
5.5 GAIN ADJUSTMENT	39
5.5.1 Steps for gain adjustment	40
5.5.2 Adjustment for speed control loop	40
5.5.3 Adjustment for position control loop	40
5.6 ELECTROMAGNETIC BRAKE	41
5.6.1 Parameters about electromagnetic brake	41
5.6.2 Matters for electromagnetic brake	42
5.7 TIMING	43
5.7.1 Timing for power on	43
5.7.2 Timing for enable operation	43
5.7.3 Timing for alarm	45
5.8 START-STOP CHARACTERISTICS	45
5.8.1 On-off frequency and load inertia	45
5.8.2 Adjustment	45
CHAPTER 6 PARAMETERS	47
6.1 PARAMETER SUMMARY	47
6.2 DETAILED PARAMETER SETTING	49
CHAPTER 7 TROUBLESHOOTING	56
7.1 FAULT MESSAGES TABLE	56
7.2 POTENTIAL CAUSE AND CORRECTIVE ACTIONS	58
CHAPTER 8 SYSTEM CONNECTION	61

Chapter 1 Model Explanation

1.1 Nameplat Information

Mode Name →

Power Supply →

Rated Current Output →

Barcode →

Attentions →

1 Read manual carefully and follow the directions.
Use proper grounding techniques.

2 Disconnect all power and wait 10 min. before servicing. May cause electric shock.

Ningbo Hirden Industrial Control System Co., Ltd

1.2 Serial Number Explanation

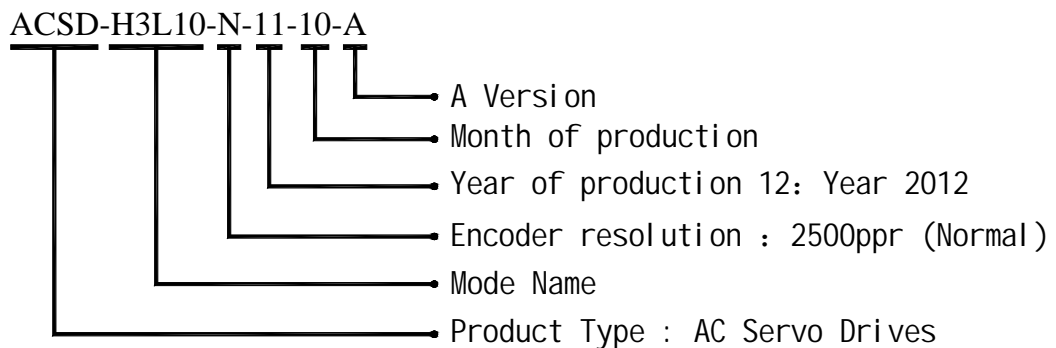

1.3 Model Name Explanation

ACSD-H3L10 Series AC Servo Drive

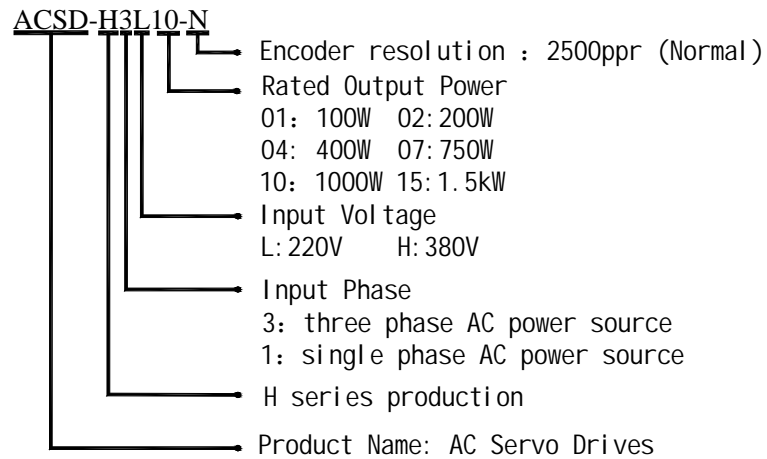

1.4 Product Part Names

ACSD-H Series Front View

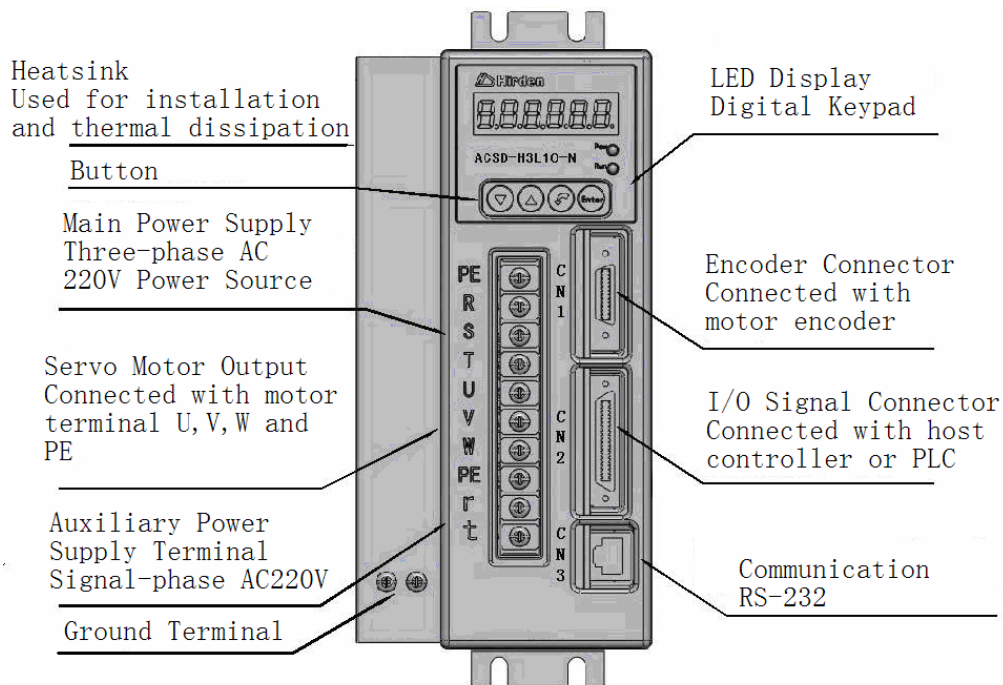

Figure 1.1 Components of H series AC servo drive

1.5 Servo Drive Specification

Table 1.1 Main specification of the H series AC servo drive

Model Name		ACSD-H3L10-N		
Power Supply	Main Power Supply	Single-phase/ Three-phase 220VAC, -10%~10% ,50Hz~60Hz		
	Control Power Supply	Single-phase 220VAC, -15%~10% ,50Hz~60Hz		
Control of Main Circuit		SVPWM		
Dynamic Brake		Built-in		
Cooling System		Natural Air Circulation		
Encoder Resolution		10000 p/rev		
Function	Position Control Mode	Max. Input Pluse Frequency	500kpps(Line driver),200kpps(Open collector)	
		Pulse Type	Pulse+Direction,CCW pulse + CW pulse,A phase+B phase	
		Electronic Gear	Electornic Gear N/M multiple N:1~32767 M:1~32767(1/50<N/M<50)	
	Speed Control Mode	Speed Control Range	1:5000	
		Analog Input Votage Range	0~±10V	
		Command Source	External analog signal / Internal parameters	
		Smoothing Strategy	Low-pass and S-curve filter	
		Torque Limit Operation	Set by parameters	
	Torque Control Mode	Analog Input Votage Range	0~±10V	
		Command Source	Internal parametersl	
		Smoothing Strategy	Low-pass	
		Speed Limit Operation	Set by parameters	
	Digital Input / Output	Inputs	Servo on	
			Pulse clear/Zero speed CLAMP/speed command selection 1	
			CCW ban(CCWL),CW ban	
			Position command ban / speed command selection 2	
		Outputs	CCW torque limit, CW torque limit	
			Encoder signal output(A,B,Z Line Driver and Z Open Collector)	
			Servo ready	
			At speed reached/ At positioning completed	
Monitor Display	Servo alarm(Servo fault) activated			
	Electromagnetic brake control			
Motor rotation speed, Motor feedback pulse number, input pulse number of pluse command, input frequcy of pulse command, position error counts, main circuit voltage, average load, absolute pulse number relative to encoder speed input command				

	Protective Functions	Overcurrent,Overvoltage, Undervoltage,Moter overheated,Regeneration error, Overload, Overspeed, Encoder error, Position excessive deviation,
Environment	Installation Site	Ndoor location(free from direct sunlight),no corrosive liquid and gas
	Altitude	Altitude 1000M or lower above sea level
	Atmospheric Pressure	86kPa~106kPa
	Operating temperature	0~45°C (if operation temperature is above 45°C, forced cooling will be required)
	Storage temperature	-20~65°C
	Humidity	0~80%RH(non-condensing)
	Vibration	0.5G

Chapter 2 Installation And Storage

The contents of this chapter is about storage and installation environment, as well as the installation considerations for the H series AC Servo Drive.

Since the storage and installation environment have an important impact on the service life and the daily performance, please refer to the following announcements about the storage and installation.

2.1 Unpacking Check

After receiving the AC servo drive, please check for the following:

Ensure that the product is what you have ordered.

Verify the part number indicated on the nameplate corresponds with the part number of your order (Please refer to Section 1.1 and 1.3 for details about the model explanation).

Check for damage.

Please inspect the unit to insure that it was not damaged during shipment.

Ensure that the servo motor shaft freely. Rotate the motor shaft by hand, a smooth rotation will indicate a good motor. However, a servo motor with an electromagnetic brake can not be rotated manually.

Check for loose screws.

Ensure that all necessary screws are tight and secure.

If any items are damaged or incorrect, please inform the distributor whom you purchased the product from or your local Hirden sales representative.

2.2 Machine Dimension

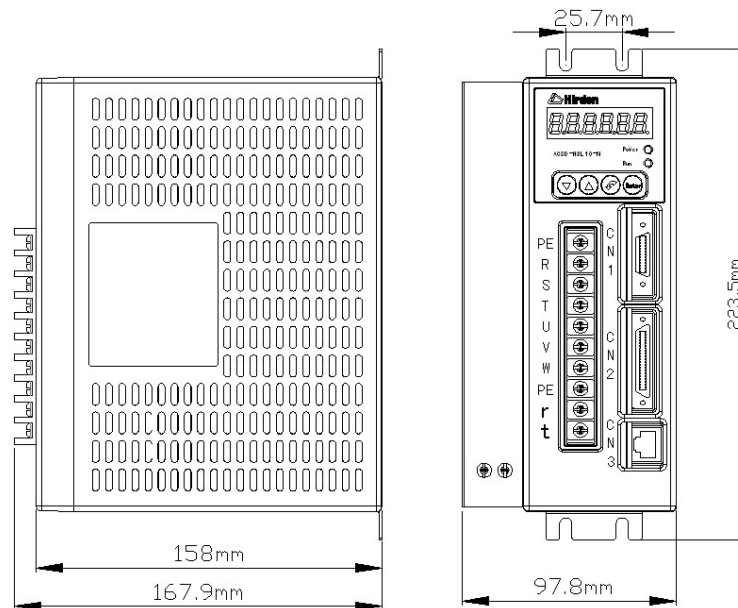

Figure 2.1 The machine dimension of the H series servo drive

2.3 Installation Environment

The operating temperature for the H series servo drive is from 0°C (32° F) to 55°C (131° F). If the ambient temperature of servo drive is higher than 45°C, please install the drive in a well-ventilated location and do not obstruct the airflow for the cooling fan. The ambient temperature of servo drive for long-term reliability should be under 45°C (113° F).

If the servo drive and motor are installed in a control panel, please ensure sufficient space around the units for heat dissipation. Pay particular attention to vibration of the units and check if the vibration has impacted the electric devices in the control panel.

Please observe the following cautions when selecting a mounting location.

1. The ambient humidity should be less than 80%, without condensing.
2. Please keep the servo drive or motor away from the heat-radiating elements or in direct sunlight.
3. Please do not mount the drive or motor in a location subjected to corrosive gases, liquids or airborne dust or metallic particles.
4. Please do not mount the servo drive or motor in a location where it will be subjected to high levels of electromagnetic radiation.
5. Please do not mount the servo drive or motor in a location where temperatures and humidity will exceed specification.
6. Please do not mount the servo drive or motor in a location where vibration and shock will exceed specification.

2.4 Installation Procedure and Minimum Clearances

Incorret installation may result in a drive malfunction or premature failure of the drive. Please follow the guidelines in this manual when installing the servo drive.

1. The servo drive should not be tilted or upside down. Please mount the drive perpendicular to the wall or malfunction and damage will occur.
2. The servo drive should be mounted in the control panel with a cooling fan, to enhance air circulation and cooling.
3. In order to ensure the drive is well ventilated, ensure that the all ventilation holes are not obstructed and sufficient free space is given to the servo drive. To define the free space, please refer to the section "Minimum Clearances".
4. Please mount the servo drive in a location where the foreign matter could be prevented to be inside the drive when the drive is operating.
5. Make sure to tighten the screws for securing drive or motor. Failure to observe this precaution may result in damage.
6. As the drive conducts heat away via the mounting, the mounting plane or surface should not conduct heat into the drive from external sources.

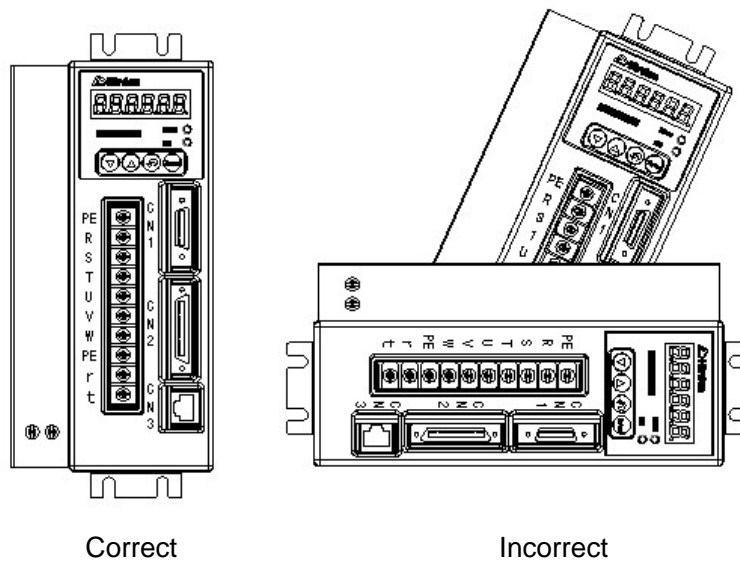

Figure 2.2 The correct direction for installation

Minimum Clearances

To increase ventilation to avoid ambient temperatures that exceed the specification, please install a fan. A minimum spacing of two inches must be maintained above and below the drive for ventilation and heat dissipation. Additional space may be necessary for wiring and cable connections. When installing two or more drives adjacent to each other, please follow the clearances as shown in the following diagram 2.3.

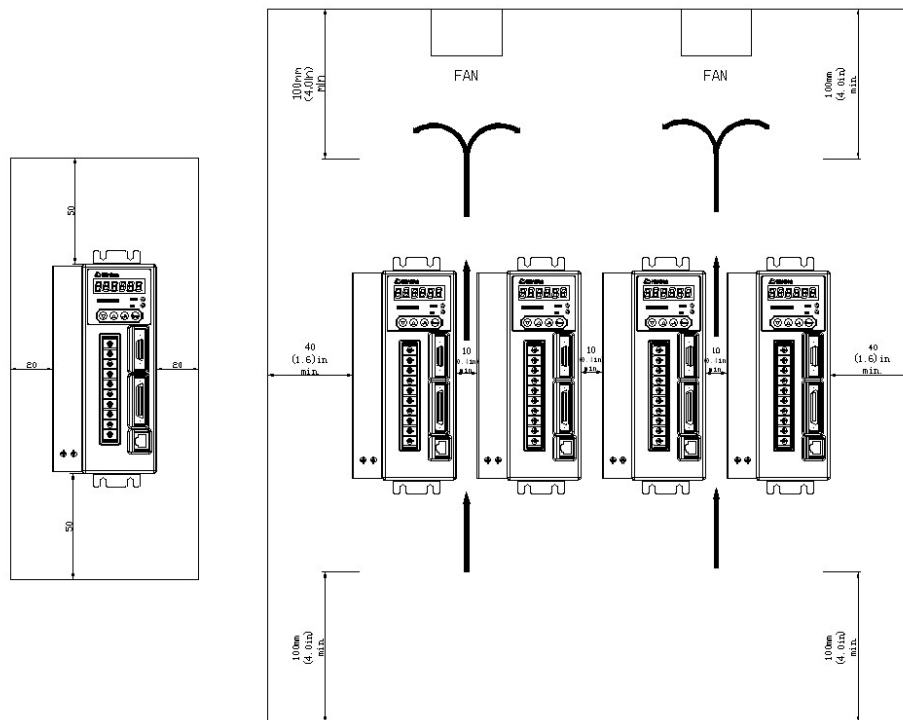

Figure 2.3 Clearances for one or two more drives.

2.5 Storage Conditions

The product should be kept in the shipping carton before installation. When it is not to be used for an extended period of time, the drive should be stored properly. Some storage suggestions are mentioned in the following:

1. Correctly packaged and placed on a solid surface.
2. Store in a clean and dry location free from direct sunlight.
3. The ambient temperature of the storage should be from -20°C (-4°F) to 65°C (149°F).
4. Store within a relative humidity range of 0% to 90% and non-condensing.
5. Do not store in a location subjected to corrosive gases and liquids.

Chapter 3 Wiring

This chapter provides information about wiring H series drives and motors, the description of I/O signals and gives typical examples of wiring diagrams.

3.1 Connectors and Terminals

Table 3.1 Appellation and intention for the connectors and terminals

Terminal Identification	Terminal Description	Notes										
R、S、T	Main circuit terminal	Used to connect three-phase AC main circuit power depending on connecting servo drive model.										
r、t	Control circuit terminal	Used to connect single-phase AC control circuit power depending on connecting servo drive model										
U、V、W、PE	Servo motor output	Used to connect servo motor <table border="1" data-bbox="804 996 1278 1249"> <thead> <tr> <th>Terminal symbol</th> <th>Wire color</th> </tr> </thead> <tbody> <tr> <td>U</td> <td>Brown</td> </tr> <tr> <td>V</td> <td>Black</td> </tr> <tr> <td>W</td> <td>Gray</td> </tr> <tr> <td>PE</td> <td>Yellow and green</td> </tr> </tbody> </table>	Terminal symbol	Wire color	U	Brown	V	Black	W	Gray	PE	Yellow and green
Terminal symbol	Wire color											
U	Brown											
V	Black											
W	Gray											
PE	Yellow and green											
PE	Ground terminal	Used to connect grounding wire of power supply or servo motor.										
CN1	Encoder connector	Used to connect encoder of servo motor. Please refer to section 3.2 for details.										
CN2	I/O connector	Used to connect external controllers. Please refer to section 3.3 for details.										
CN3	Communication connector (Option)	Used for RS-232 communication connection.										

Table 3.2 Cable specifications for servo drive

Terminal Identification	Terminal Description	Power Cable – Wire gauge
R、S、T	Main circuit terminal	1.5~2.5mm ²
r、t	Control circuit terminal	0.75~1 mm ²
U、V、W	Servo motor output	1.5~2.5 mm ²
PE	Ground terminal	1.5~2.5 mm ²
CN1	Encoder connector	≥0.14 mm ² , 7 pair shielded twisted-pair cable
CN2	I/O connector	≥0.14 mm ² , shielded twisted-pair cable

Wiring Notes:

Please observe the following wiring notes while performing wiring and touching any electrical connections on the servo drive or servo motor.

1. Ensure to check if the power supply and wiring of the “power” terminals (R, S, T, r, t) is correct.
2. Please use shielded twisted-pair cables for wiring to prevent voltage coupling and eliminate electrical noise and interference.
3. Ensure to check if the U, V, W terminal is correct, or the motor maybe not turn or cause galloping.
4. The ground terminal of the servo drive and motor should be connect to the terminal which is well grounded into a single-point ground, and the ground wire should be rough.
5. As a residual hazardous voltage may remain inside the drive, please do not immediately touch any of the “power” terminals (R, S, T, r, t, U, V &W) or the cables connected to them after the power has been turned off and the charge LED is lit.
6. Please use a twisted-shield signal wire with grounding conductor for the encoder cable (CN1) and the position feedback signal connector (CN2). The wire length should be 20m or less. If the length is greater than 20m, the wire gauge should be doubled in order to lessen any signal attenuation.
7. The shield of shielded twisted-pair cables should be connected to the SHIELD end (ground terminal) of the servo drive.
8. The cable connected to R, S, T and U, V, W terminals should be placed in separate conduits from the encoder or other signal cables. Separate them by at least 30cm.
9. Ensure to check if the direction of the diode for the relay is correct, or damage will occur as a result.
10. Please install a NFB to prevent excessive current which may arise due to short-circuit or flow when power on an power off, so as to avoid the damage on the servo drive.

11. Please turn off the power supply, if the drive will not be used for a long time.
12. The direction definition of rotation: facing the motor shaft, the counter-clockwise direction is defined as the CCW. And the clockwise direction of rotation is defined as the CW. The CCW is the positive direction, and CW as negative direction.

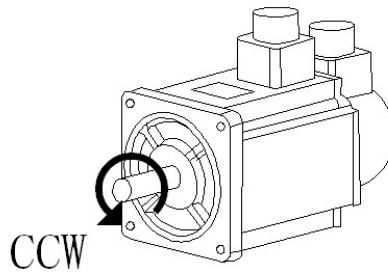

Figure 3.1 The definition of the direction for the rotation

3.2 Encoder Connector CN1

H series servo drive is applicable for incremental encoder which contains A, B, Z, U, V, W signals and the resolution is 2500ppr. The 2500ppr encoder is automatically multiplied to 10000 pulses each circle for increasing control accuracy.

3.2.1 The Layout and View of CN1

The CN1 encoder signal interface terminal is called SCSI 26 produced by 3M, the view and the layout of the CN1 is shown as the following:

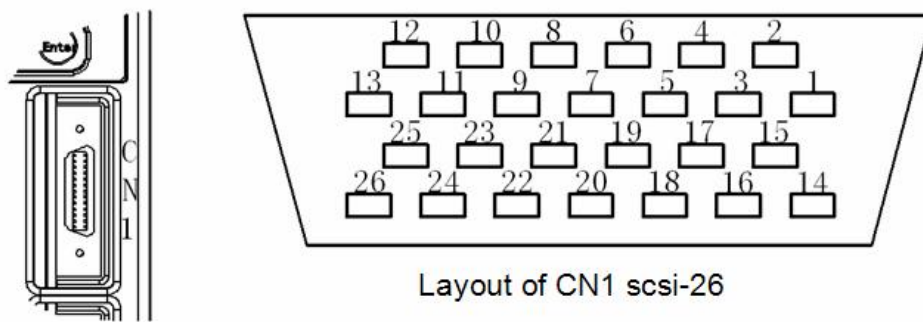

Figure 3.2 The view and layout of the CN1 encoder signal interface terminal

3.2.2 Signal Identification for CN1

Table 3.3 Terminal signal identification for CN1

PIN No.	Terminal Identification	Motor connector		
		Quick connector	I/O type	Description
1	A+	4	Type7	Connected to A+ signal
2	A-	7		Connected to A- signal
3	B+	5	Type7	Connected to B+ signal
4	B-	8		Connected to B- signal
5	Z+	6	Type7	Connected to Z+ signal
6	Z-	9		Connected to Z- signal
7	U+	10	Type7	Connected to U+ signal
8	U-	13		Connected to U- signal
9	V+	11	Type7	Connected to V+ signal
10	V-	14		Connected to V- signal
11	W+	12	Type7	Connected to W+ signal
12	W-	15		Connected to W- signal
14、15、 16、17	Power supply 5V	2	--	+5V power source is supplied for the servo motor encoder. When the length of the cable is greater, please take several core wires in parallel to reduce line drop.
18、19、 20、21、 22、23	GND	3	--	
26、27、 28	Shielding	1	--	Shielding (PE)

3.3 I/O Interface Connector CN2

The CN2 interface connector provides access to three signal groups:

1. General interface for the analog speed and torque control, pulse / direction inputs, and reference voltages.
2. 8 programmable Digital Inputs (DI)
3. 4 programmable Digital Outputs (DO)

A detailed explanation of each group is available in section 3.3.2

3.3.1 The Layout and View of CN2

The CN2 I/O interface terminal is called SCSI 36 produced by 3M, the view and the layout of the CN2 is shown as the following:

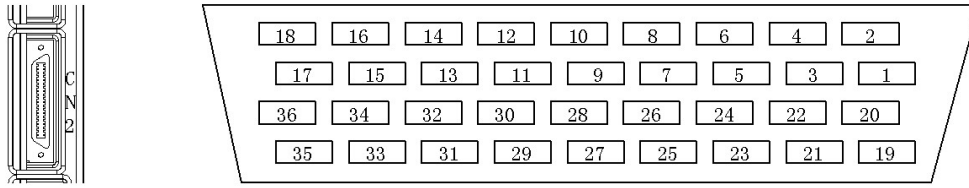

Figure 3.3 The view and layout of the CN2 I/O interface terminal

3.3.2 Signals Explanation of Connector CN2

Table 3.4 CN2 Terminal Signal Identification

Pin No.	Signal name	Terminal		Description
		Identification	I/O type	
1	Encoder Signal A	OA+	5	Encoder signal output A, B, Z (Line-driver output). The motor encoder signals are available through these terminals.
2	Encoder Signal B	OA-	5	
3	Encoder Signal Z	OB+	5	
4	Encoder Signal Z	OB-	5	
5	Encoder Signal Z	OZ+	5	
6	Encoder Signal Z	OZ-	5	
7	Encoder Signal CZ	OCZ	6	Encoder signal Z open-collector output.
8	Common Ground	GND	5	Reference ground for encoder signal.
9				
10	Servo Enable	SON	1	Servo enable signal input terminal. SON ON: enable the drive. SON OFF: drive off and the motor is in a free state. Note 1: The motor must be before enable the drive. Note 2: Any other command should be inputted after the son on signal at least 50ms.
11	Alarm Clear	ALRS	1	Clear alarm signal input termina. ALRS ON: reset the alarm of the servo system ALRS OFF: no action Note 1: This function does not work on the UV and OC error, which needed to restart the drive.

12	Forward Software Limit	FSTP	1	<p>CCW (counter-clockwise direction) software limit input interminal.</p> <p>FSTP ON: the motor can be drived in the counter-clockwise direction.</p> <p>FSTP OFF: the motor can't be drive in CCW.</p> <p>Note 1: To disable this function, you could set the PA20=1, which enables CCW or CW drive allows without the DI.</p>
13	Reverse Software Limit	RSTP	1	<p>CW (the clockwise direction) software limit input interminal.。</p> <p>PSTP ON: the motor can be driven in the clockwise direction.</p> <p>PSTP OFF: the motor can't be drive in CW.</p> <p>Note 1: To disable this function, you could set the PA20=1, which enables CCW or CW drive allows without the DI.</p>
14	Speed Command Selection 1	SC1	1	<p>The input interminal is defined as the speed comand selection in the speed control model (PA4=1) when the parameter PA22=0 which determinds the internal or external command as the speed command source. Used to select the different internal speed through the combination of SC1 and SC2.</p> <p>SC1 OFF, SC2 OFF: internal speed 1.</p> <p>SC1 ON, SC2 OFF: internal speed 2.</p> <p>SC1 OFF, SC2 ON: internal speed 3.</p> <p>SC1 ON, SC2 ON: internal speed 4.</p> <p>Note: the value of the internal speed command could be modified by corretation parameter.</p>
	Deviation Counter Reset	CLE		<p>When PA4=0 the terminal is defined as deviation counter reset function:</p> <p>CLE OFF: remain deviation counter.</p> <p>CLE ON: reset deviation counter.</p>
	Zero Speed Clamping	ZERO		<p>In the speed control model when PA22=1 the input interminal is defined as the zero speed clamping function.</p> <p>ZERO OFF: analog input intruction is selected.</p> <p>ZERO ON: speed command is set to 0.</p>

15	Speed Command Selection 2	SC2	1	The input interterminal is defined as the speed command selection in the speed control model when PA4=1 and PA22=0. Used to select the different internal speed through the combination of SC1 and SC2. SC1 OFF, SC2 OFF: internal speed 1. SC1 ON , SC2 OFF: internal speed 2. SC1 OFF, SC2 ON : internal speed 3. SC1 ON , SC2 ON : internal speed 4.
	Input Pulse Prohibition	INH		When PA4=0, the terminal is defined as input pulse prohibition. INH OFF: disable the funcion. INH ON: enable the function.
16	Forward Torque Limit	FIL	1	CCW torque limit input interterminal. FIL ON: the torque is limited in the PA36 range. FIL OFF: the torque is not limited. Note: in any case, the torque is limited in the PA34 range
17	Reverse Torque Limit	RIL	1	CW torque limit input interterminal. RIL ON: the torque is limited in the PA37range. RIL OFF: the torque is not limited. Note: in any case, the torque is limited in the PA35 range
18	Power Supply Input Terminal	COM+	1	COM+ is the common voltage rail of the DI and DO signals. The range is DC12~24V and the available current should be greater than 100mA
19	Analog Speed Command	AS+	4	Motor speed command: -10V~+10V, corresponds to -3000~+3000 r/min command and the input impedance is 10kΩ
20		AS-		
21	Torque Command	AT+	4	Motor torque command: -10V~+10V, corresponds to -100%~+100% rated command and the input impedance is 10kΩ
22		AT-		
23	Analog Ground	AGND	4	The reference ground for DI signals.
24	Servo Ready Output	SRDY+	2	Servo ready signal output terminal. SRDY is activated when the servo drive is ready to run. All fault and alarm conditions, if present, have been cleared.
25		SRDY-		
26	Servo Alarm Output	ALM+	2	Servo ready signal output terminal. ALM is activated when the drive has detected a fault condition.
27		ALM-		

28	Reaching Target Speed or Completing Positioning	COIN+	2	In the position control mode (PA4=0), COIN is activated when the position error is equal and below the setting value of PA16. 。 In the speed control mode (PA=1), COIN will be activated when the drive has detected the motor has reached the Target Rotation Speed setting as defined in parameter PA28.	
29		COIN-			
30	Brake Release Signal	BRK+	2	BRK is activated actuation of motor brake.	
31		BRK -			
32	Position Pulse Input	PULS+	3	The drive can accept two different types of pulse inputs: Line-drive input (max. input frequency is 500Kpps) and Open-collector input (max.input frequency is 200Kpps). Three different pulse commands can be selected by PA-4.	
33		PULS -			
34	Position Sign Input	SIGN+	3		
35		SIGN -			
36	Shield	PE			Shielding
37					
38					

3.4 I/O Interface Type

3.4.1 Digital signal input interface

Digital signal input interface circuit is generally composed by optocouplers, switches, relays open-collector transistors or other components as shown in the following figures.

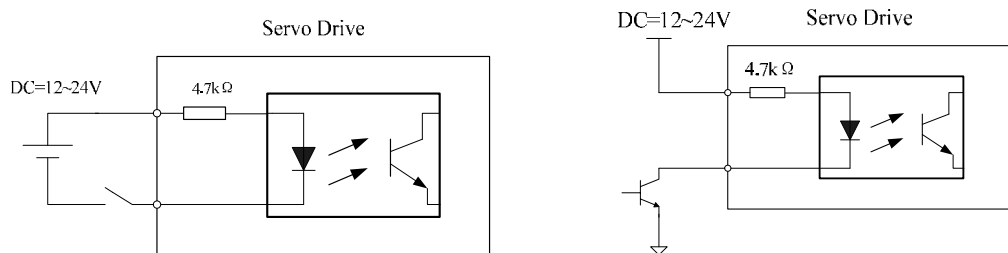

Figure 3.4 Digital signal input interface circuit type 1

1. The voltage of the external power is DC12~24V and available current should be 100mA at least.
2. Ensure that the polarity of the power is correct, otherwise it will damage the drive.

3.4.2 Digital signal output interface

The digital signal output interface circuit composed by optocouplers should be connected to the optocoupler or relay to achieve transferring the isolated digital signal.

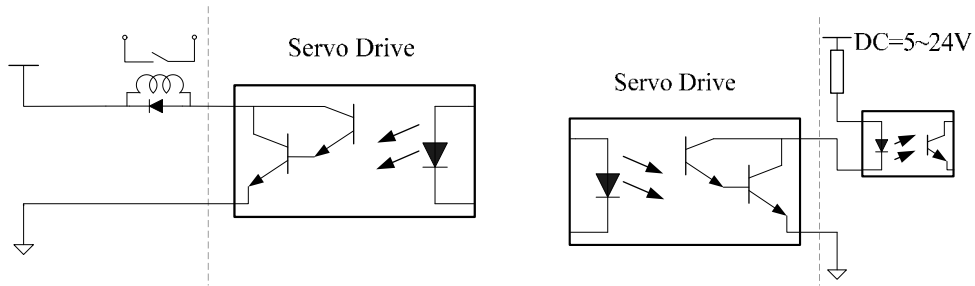

Figure 3.5 Digital signal output interface circuit type 2

1. The voltage of the external power is DC5~24V.
2. The output form of optocoupler is open-collector, the max. current is 50ma and the external max. DC voltage is 25V.
3. When the load is relays or other inductive load, freewheeling diode is needed to parallel at the both ends of the inductive components. Ensure the polarity of the diode, otherwise damage may occur.

3.4.3 Position pulse input interface

The drive can accept two different types of pulse inputs: Line-drive input and Open-collector input. The max. input frequency of line-drive input with strong anti-jamming capability is 500Kpps and the one of the Open-collector input is 200Kpps. For reliable pulse signal, the Line-drive input circuit is recommended.

1. Diagram for Line-drive input circuit

In the Line-drive mode, AM26LS31, MC3487 or RS422 is used in the Line-drive output circuit of the host controller.

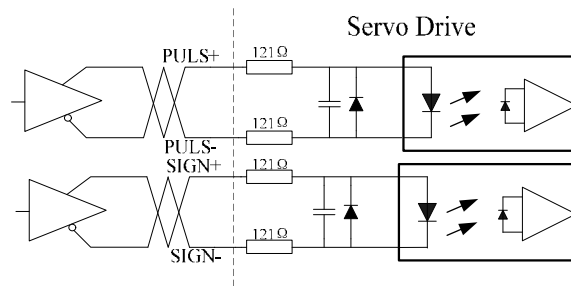

Figure 3.6 Pulse input interface circuit type 3 (Line-drive input circuit)

2. Diagram for Open-collector input circuit

The source of pulse input is from the open collector NPN equipment and use the external power supply. This input mode will reduce the operating frequency.

The driving current of the circuit is 10~15mA, please determine the desired resistance of the resistor R by the DC power supply voltage.

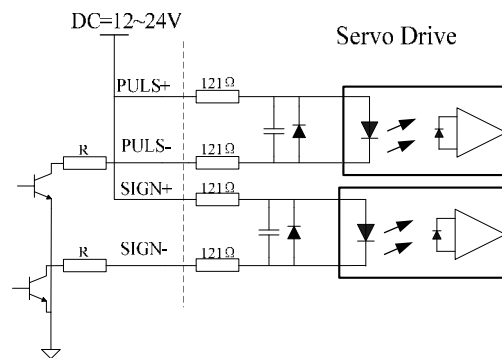

Figure 3.7 Pulse input interface circuit type 3 (Open-collector input circuit)

3.4.4 Analog signal input interface

There are two different input circuit types of analog signal: differential input mode and single-ended input mode. The differential input circuit can inhibit the common-mode interference, so the differential input mode is recommended.

Either analog speed command or torque command is needed for “H” series servo drive. The voltage range for the analog command is DC-10V~+10V, and the input impedance is 10kΩ. The zero drift of the analog signal could be compensated by adjusting the parameters.

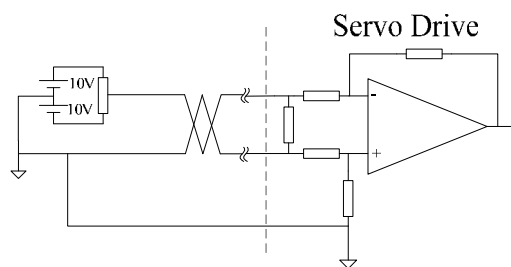

Figure 3.8 Analog signal input interface circuit type 4 (differential input mode)

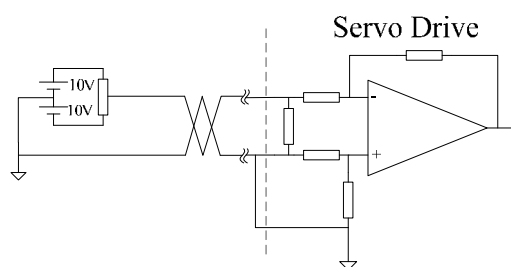

Figure 3.9 Analog signal input interface circuit type 4 (single-ended input mode)

1. Three connecting wires are needed in differential input mode, but only two connecting wires in single-ended input mode..
2. The voltage of the signal should not be beyond the specified range (-10V~+10V) or may damage the drive.
3. This interface is a non-isolated input interface, so the shielded cable is recommended to reduce the noise.

3.4.5 Encoder signal output interface

The drive outputs the motor encoder feedback position signals by Line-drive transmitter chip AM26LS31. The user could receive the encoder A phase, B phase and Z phases signals by two types: Line-drive receiver chip and the high-speed optocoupler.

The host controller receives the encoder signals by Line-drive receiver chip. The circuit connected to the drive is shown as the following.

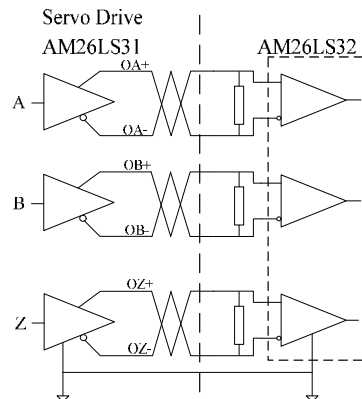

Figure 3.10 Encoder position signals output interface circuit type 5 (Line-drive)

The value of the resistance is $220\Omega\sim 470\Omega$, and the common ground (GND) of the encoder should connect with the signal ground of the host controller.

For the interface is a non-isolated input interface, when the host controller receives the position signals by high-speed optocoupler, the current-limiting resistance whose value is 220Ω should be in series to the receiving circuit. And the interface circuit is shown as the following.

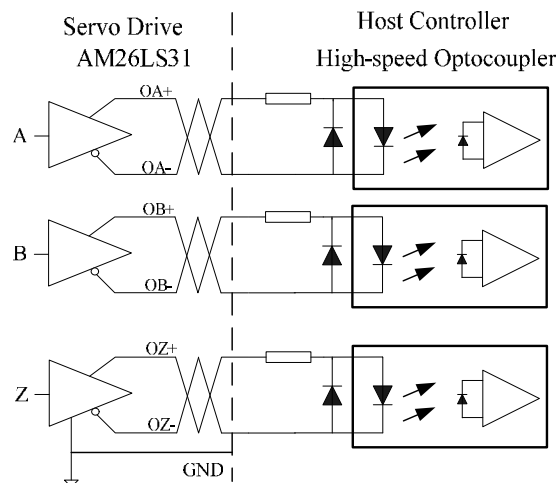

Figure 3.11 Encoder position signals output interface circuit type 5 (optocoupler)

3.4.6 Encoder Open-collector Z-pulse output interface

The width of the zero position pulse is narrow, therefore the high-speed optocoupler is recommended as the receiver. This interface is a non-isolated input interface, the max.

current is 50mA and the max. voltage is 30V. The specific interface circuit is shown as the following.

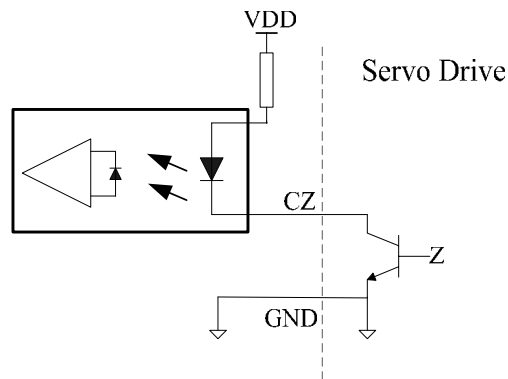

Figure 3.12 Encoder Open-collector Z-pulse output interface circuit type 6

3.4.7 Encoder feedback signal input interface

The servo drive receive the encoder feedback signal by the Line-drive receiver IC such as AM26LS32, and the circuit is shown as the following.

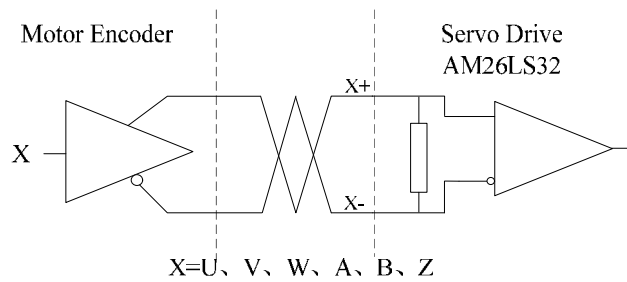
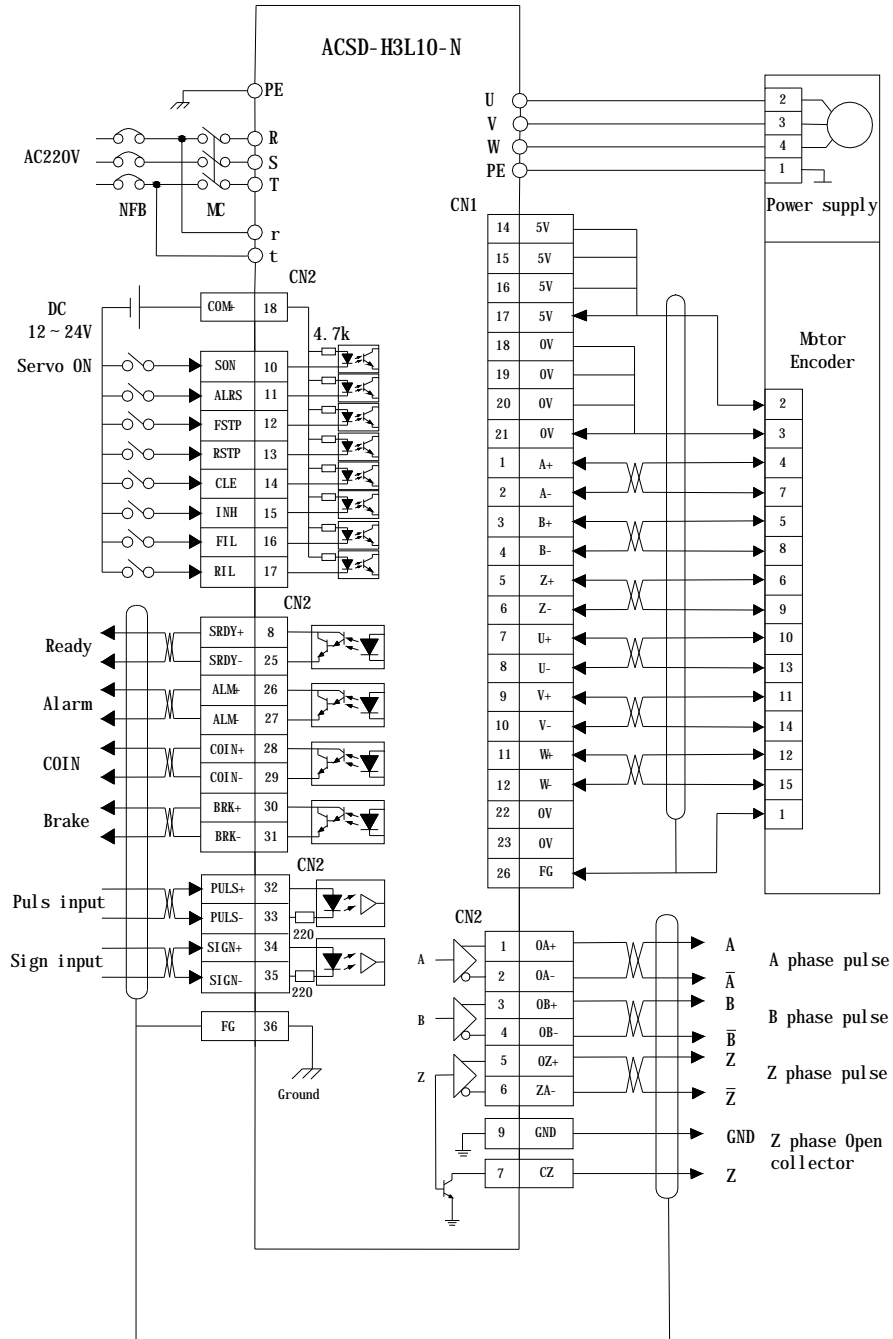

Figure 3.13 Encoder feedback signal input interface circuit type 7

3.5 Standard Connection Example

3.5.1 Position control mode



3.5.2 Speed control mode

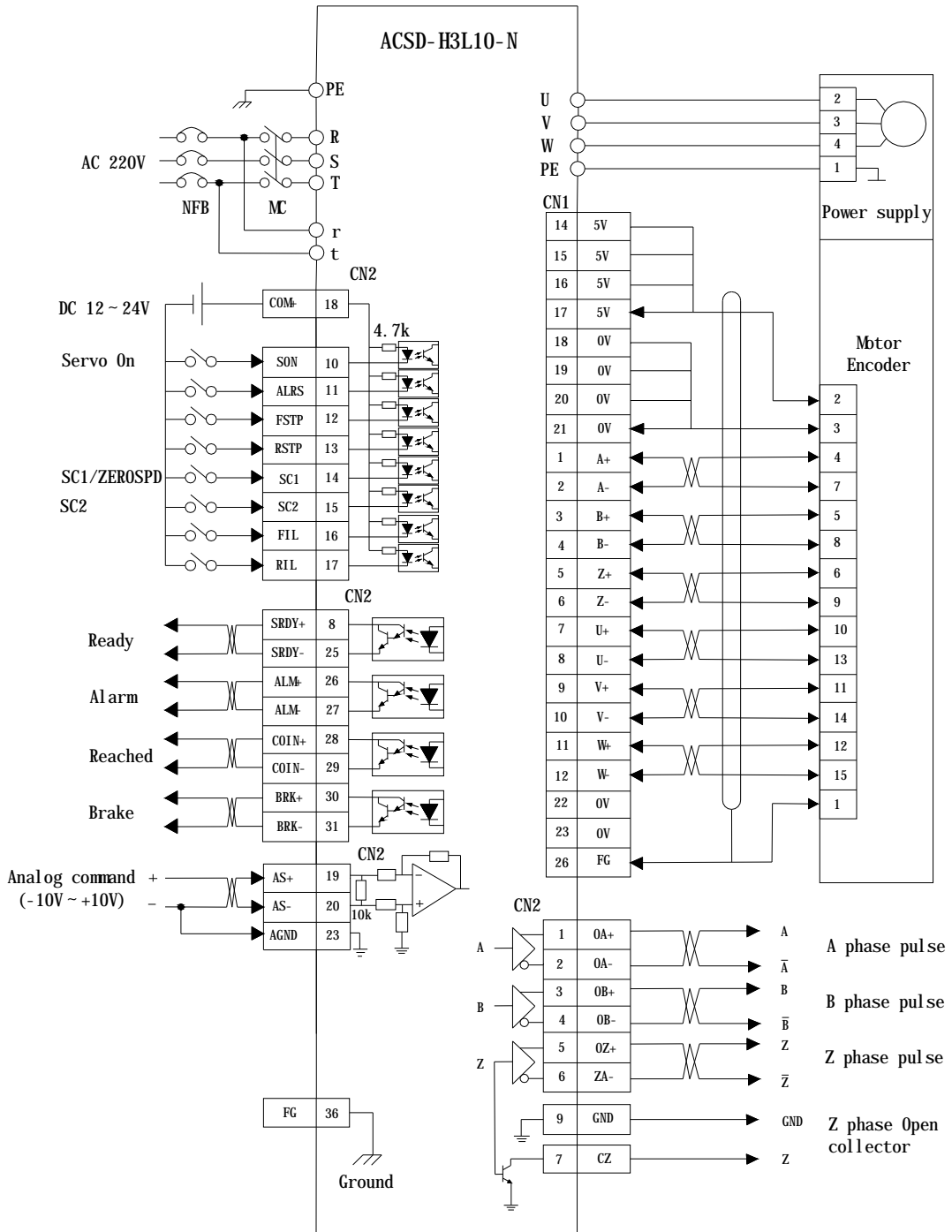

3.5.3 Torque control mode

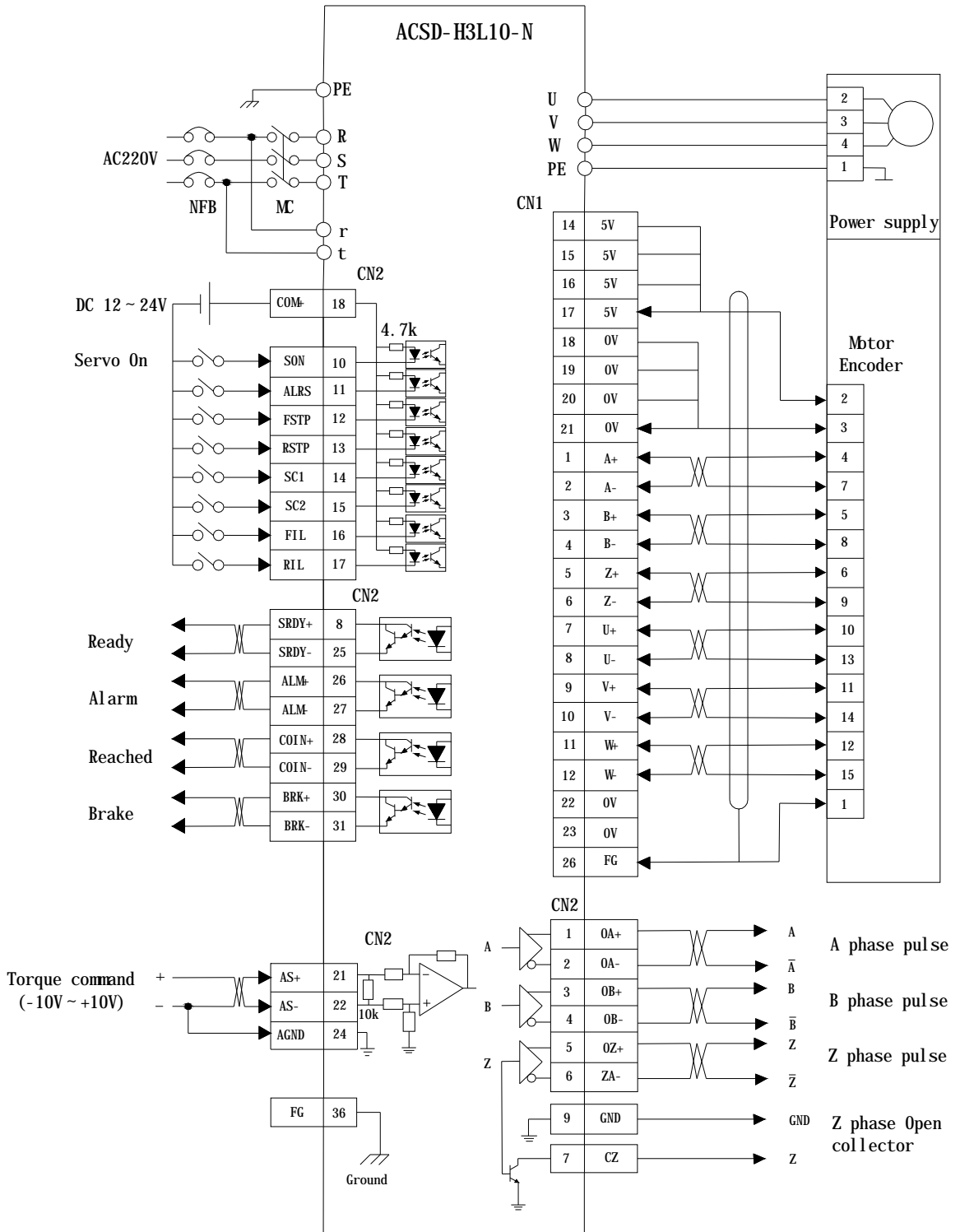

Chapter 4 Display and Operation

This chapter describes the basic operation of the digital keypad and the features it offers.

4.1 Description of the digital keypad

The digital keypad includes 4 function keys and the display panel which is composed of 6 LED. The Figure 4.1 shows all of the features of the digital keypad and an overview of their functions.

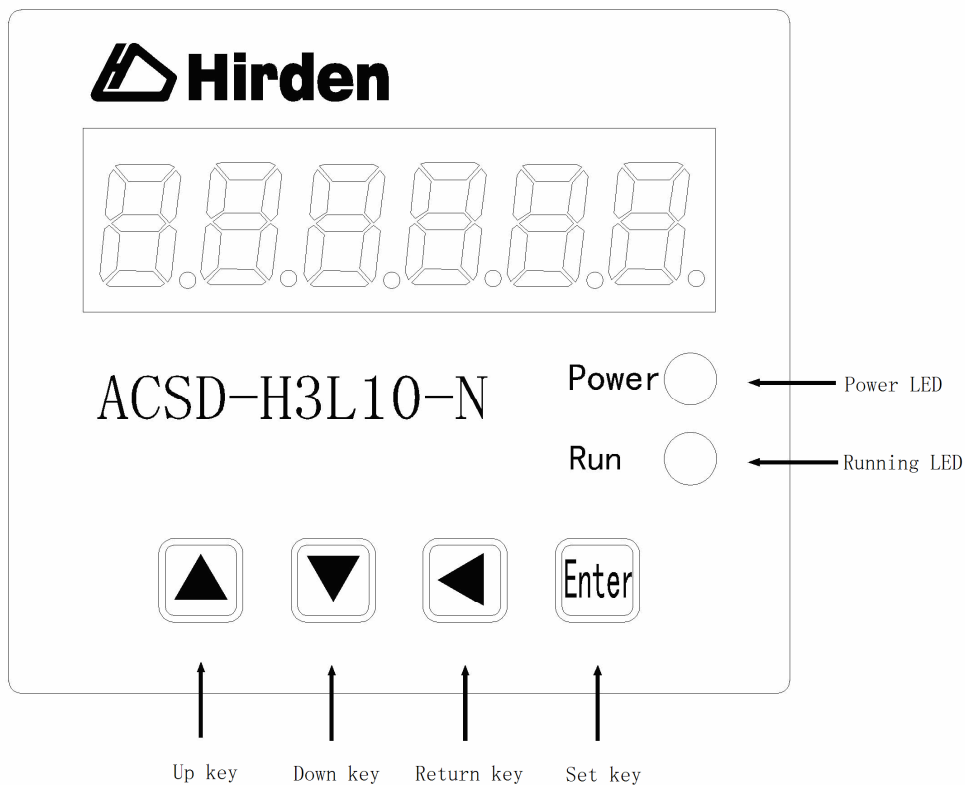

Figure 4.1 Overview about the keypad

Table 4.1 Function instructions for the digital keypad

Symbol	Name	Function
Power	Power supply	The LED light to indicate the control power is applied.
Run	Running status	The LED lights to indicate the main power is applied to the circuit and the drive is enabled.
▲	Up key	Pressing the Up and Down key can scroll through and change monitor codes, parameter groups and various parameter settings.
▼	Down key	
◀	Return key	Pressing the Return key can exit the menu or cancel the operation or the settings.
Enter	Set	Pressing the Set key can enter the menu or determine and save the operation or the parameter settings.

Note : If some fault occurs, the 6 bit LED display will be blinking.

4.2 Main menu

As the first layer of the operational processes, the main menu consists of six parts. You can use the Up and Down key to change the content of the main menu display and press the Set key to enter the second layer, as well you could press the Return key to quit the second layer to the main menu.

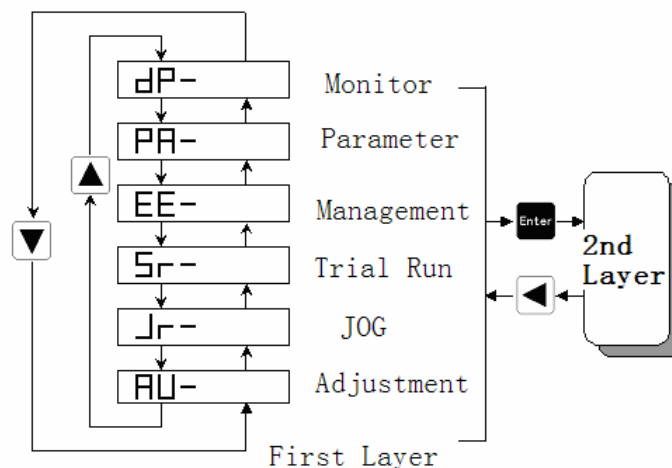

Figure 4.2 Flowchart for the main menu of the operational processes

4.3 Monitor Display (DP--)

Users could press the Up and the down key to find the monitor display of the main menu. When “dp-” is displayed, please press the Set key to enter the layer for monitor mode. There

are 19 kinds status for the monitor display shown as the following. You could select the display you need using the Up and Down key and then press the Set key to enter the specific monitor and display interface.

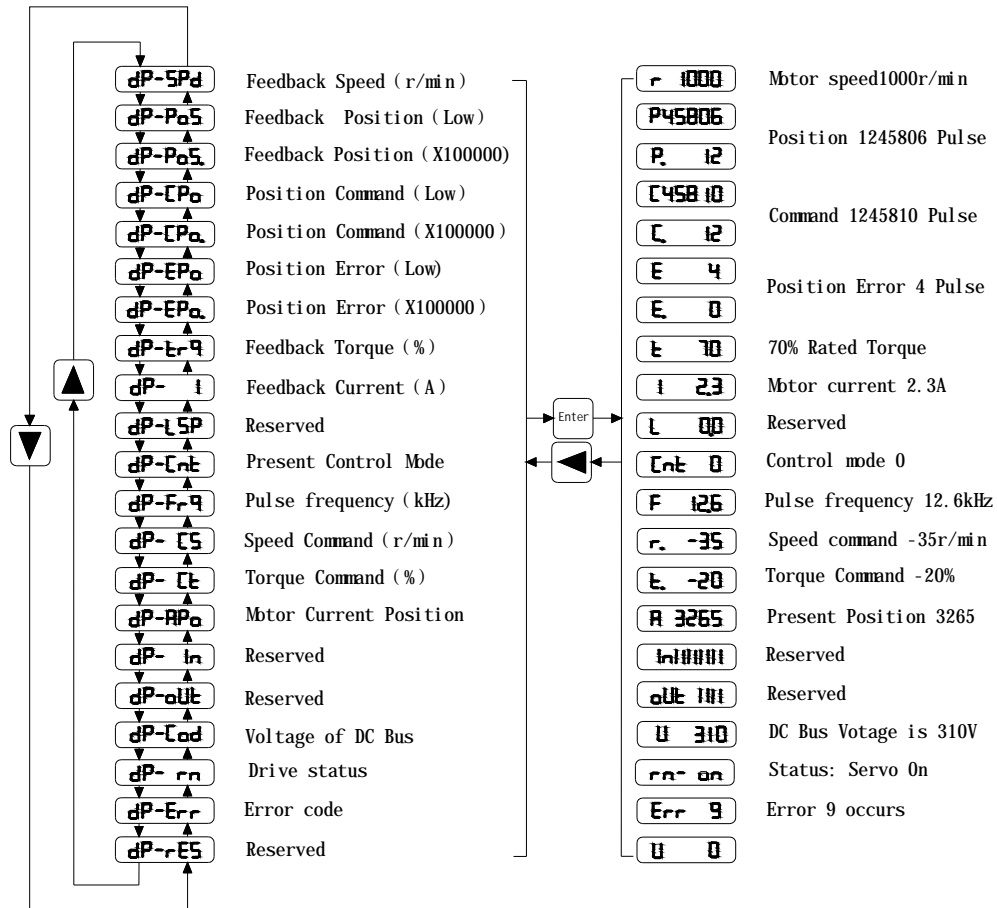

Figure 4.3 Diagram for the operational processes of the monitor display

4.4 Parameter setting (PA--)

You could find the "PA-" on the main menu by using the Up and Down key, and then enter the parameter selection interface by pressing the Set key. By using the Up and Down key you could select the parameter which you want to change, and then press the Set key to enter the parameter modification interface. You could use the Up and Down key to change parameter to the value you required. When the parameters is modified, the point of the last LED digital tube will be light, that means the parameter is changed but not yet be effective. You could press the Set key to make it, then the point will go out. You could use the Return key to quit.

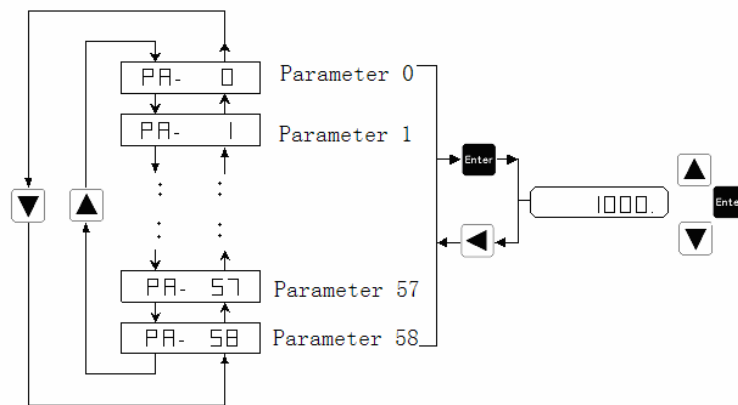

Figure 4.4 Diagram for the operational processes of parameter setting

4.5 Parameter Management (EE--)

You could find the “EE-” on the main menu by using the Up and Down key, and then enter the parameter management interface by pressing the Set key. The representative meaning of each symbol is shown in the figure 4.5. By using the Up and Down key you could select the operation which you need. And then press and hold the Set key for 3 seconds, when “FINISH” is displayed on the LED means the operation is completed. But if “Error” is displayed, the operation fails, and then please press the Return key to quit.

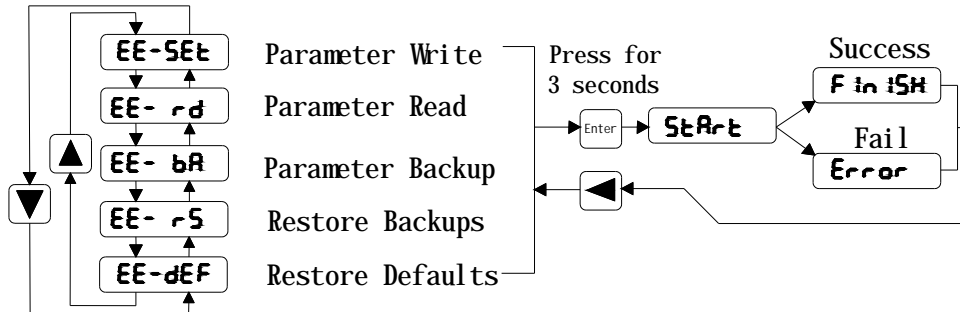

Figure 4.5 Diagram for the operational processes of parameter management

- EE-set Write operation: the parameters will be written in the parameters district of the EEPROM. Even if the power is down the parameter will not be lost.
- EE-rd Read operation: read the data from the parameter district of the EEPROM to the parameter list of the software. If the parameter are modified to result in an error by improper operation, you could use this feature to restore the parameters.
- EE-rs Restore the parameter: read the data svaed in the backup area of the EEPROM into the parameter list of the software. If you want the backup parameter be long-term effective, you need to perform a write operation.

- EE-def Restore the default parameters: read all of the defaults into the parameter list, and then write the parameters into the EEPROM. Even if the drive is restart, the defaults is still effective. After this operation, you should ensure that the motor code (PA1) is adapted for the using motor.

4.6 Speed trial run without load (Sr--)

You can enable the “Sr” operation mode by set parameter PA4=3. You could find the “Sr-” on the main menu by using the Up and Down key, and then enter the speed trial run operation interface by pressing the Set key. When “Sr 0.0” is displayed and the units is r/min, you could change the speed command by pressing Up or Down key.

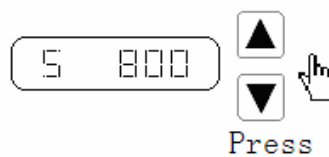

Figure 4.6 Diagram for the speed command entering of speed trial run

4.7 JOG trial run without load (Jr--)

You can enable the “Sr” operation mode by set parameter PA4=4 and change the JOG speed command by seting parameter PA 21. You could find the “Jr-” on the main menu by using the Up and Down key, and then enter the JOG trial run operation interface by pressing the Set key. When “J 0.0” is displayed and the units is r/min, you could press Up or Down key to jog the motor CCW or CW direction. The motor will only rotate while the arrow key is activated.



Figure 4.7 Diagram for the JOG trial run

4.8 Zero-offset adjustment

By the operation the drive could automatically detects the zero bias of the analog speed or torque command, and write the value in the parameter PA45 or PA39. At last the drive will save the parameter in the EEPROM automatically. You could find the “AU-” on the main menu by using the Up and Down key, and then enter the operation interface for Zero-offset adjustment by pressing the Set key. The AU-SPD correspond to the speed zero-offset adjustment and the AU-trq correspond to torque zero-offset adjustment. You could select the process by Up or Down key, and then you should press and hold the Set key for 3 seconds till

the LED displays "FINISH".

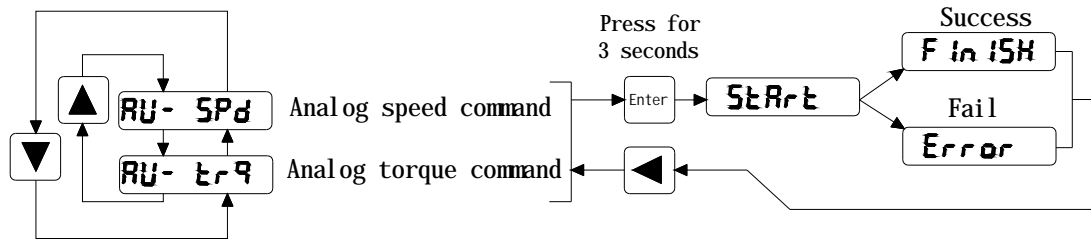

Figure 4.8 Diagram for the operational processes of analog zero-offset adjustment

Chapter 5 Trial Run and Tuning Procedure

This chapter describes trial run for servo drive and motor, including the trial run without load and introductions about the operation mode of the drive. Ensure to complete the trial run without load first before performing the trial run with load.

5.1 Inspection without load

In order to prevent accidents and avoid damaging the servo drive and mechanical system, the trial run should be performed without load. Please disconnect all couplings and belts and do not run servo motor while it is connected to load or mechanical system, for the unassembled parts on motor shaft may easily disassemble during running and it may damage mechanical system or even result in personnel injury.

Please perform trial run without load first and then perform trial run with load connected.

Before the servo is powered, please observe the following cautions:

1. Ensure whether there is obvious damage on the appearance of the drive and motor.
2. Check whether all of the wiring is correct or not, especially for the R, S, T, U, V, W and PE terminal. The terminals should be connected to the specified cable and terminal.
3. Ensure that there is no foreign matter inside the drive, such as conductive objects and flammable objects.
4. Confirm that the electromagnetic brake could work normally, if the brake is being used.
5. Ensure that the specification for the power is applicable.
6. Make sure that the cable and the mechanical parts are not intertwined, to avoid wear or pulling phenomenon at the run time.
7. Verify that the servo drive and motor are connected to the ground reliably.
8. Make sure control switch is OFF.

After the control power is applied, please observe the following cautions:

1. Ensure that the power indicator and LED display is normal. If there is any abnormal condition of the power indicator and LED display, please contact your distributor for assistance or contact with Hirden.
2. Check that all user-defined parameters are set correctly. For the characteristics of different machinery equipment are not the same, in order to avoid accident or cause damage, do not adjust the parameter abnormally and ensure the parameter setting is not an excessive value.
3. Make sure that the servo drive is off when you reset some parameters.
4. Check for abnormal vibrations and sounds during operation. If the servo motor is vibrating or there are unusual noises while the motor is running, please contact the dealer or manufacturer for assistance.
5. If there is no contact sound or there be any unusual noises when the relay inside the servo drive is operating, please contact your distributor for assistance or contact with Hirden.

5.1.1 Applying power to the drive

Please check the wiring first. If there is no abnormal condition, you could turn on the control power supply (the main power should be OFF). If any error except error 3 is displayed on the LED, please check the wiring and the parameter, or you could refer to the chapter 7.

Secondly please turen on the main power supply, and the running indicator will be lit. If the indicator has not been lighted or any other error occurs, please check the main power supply and the parameter PA53. And at last you could refer to chapter 7.

5.1.2 JOG trial run without load

It is very convenient to use JOG trial run without load to test the servo drive and motor as it can save the wiring. For safety, it is recommended to set JOG speed at low speed such as 100r/min. The JOG speed could be set in the parameter PA21.

1. Parameters

Table 5.1 Parameters about the JOG trial run

Parameter NO.	Name	Default	Setting	Description
PA04	Control Mode	0	4	Select the operation mode as JOG trial running mode.
PA20	Inhibit Drive Function	1	1	Ignore the drive prohibition
PA21	JOG speed	120	100	Speed command for JOG
PA40	Acceleration Time	0	Opportune	Reduce the acceleration shocks.
PA41	Deceleration Time	0	Opportune	Reduce the deceleration shocks.
PA53	Enabled Word 1	0000	0001	Enable the drive without the external signal

2. Operation

Step 1: Enable the drive and the running indicator will be lit by setting the parameter PA53=0001. And then the servo drive and motor is at zero speed running state.

Step 2: Set parameter PA21 as JOG speed. After the desired JOG speed is set, and then press the Set key, the speed will be write into the control software.

Step 3: Enter the JOG operation interface by using the digital keypad, and the digital LED display should be displayed as the following:

J 0.0 (r/min)

Step 4: Pressing the Up key and the servo motor will run in CCW direction. After releasing Up key, the motor will stop running.

Step 5: Pressing Down key and the servo motor will run in CCW direction. After releasing Down key, the motor will stop running.

Step 6: When preessing Return key, the drive could exit JOG operation mode.

CCW and CW definition.

CCW(counterclockwis): when facing the servo motor shaft, CCW is running in the counterclockwise direction.

CW(clockwis): when facing the servo motor shaft, CW is running in clockwise direction.

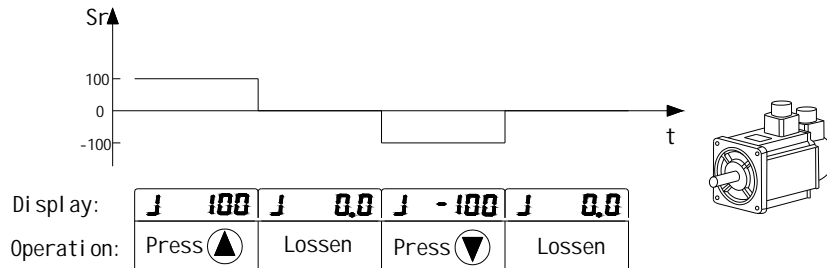

Figure 5.1 Diagram for the JOG trial run without load

5.1.3 Speed trial run without load

Before speed trial run, fix and secure the motor as possible to avoid the danger from the reacting force when motor speed changes.

1. Parameters

Table 5.2 Parameters about the speed trial run

Parameter NO.	Name	Default	Setting	Description
PA04	Control mode	0	3	Select the operation mode as speed trial running control mode.
PA20	Inhibit Drive Function	1	1	Ignore the drive prohibition
PA53	Control word 1	0000	0001	Enable the drive without the external signal

2. Operation

Step 1: Enable the drive and the running indicator will be lit by setting the parameter PA53=0001. And then the servo drive and motor is at zero speed running state.

Step 2: Set parameter PA04 =3, choosing the speed trial running mode as the current mode.

Step 3: The speed command of the speed trial running is input by pressing Up and Down keys and the minimum given value is 0.1r/min. Use the Up or Down key to select the “Sr” mode on the main menu, and the press the Set key to enter the operation interface for the speed trial running. And the LED display should be shown as the following:

S 0.0 (r/min)

Positive instruction means that the servo motor runs in the CCW direction, and the negative instruction means that the motor runs in the CW direction.

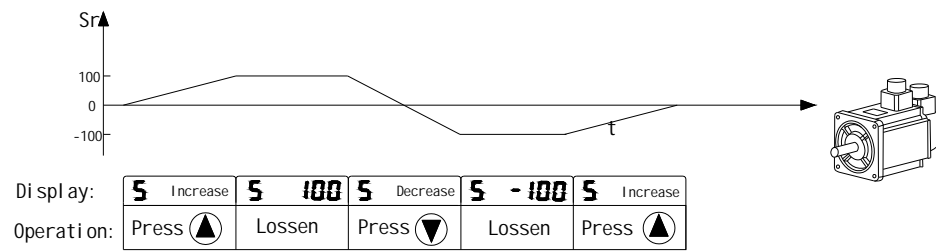

Figure 5.2 Diagram for speed trial run

5.2 Position control mode

The position control mode is usually used for the applications requiring precision positioning, such as industry positioning machine, indexing table etc. Before position trial run, please observe the following cautions:

1. Ensure that all wiring is correct and wiring terminals of the servo drive and motor are correctly insulated, or damage and malfunction may result.
2. Check whether the motor and the drive is fixed and secure, or the motor or drive may be damaged by the reacting force when motor speed changes.

5.2.1 Simple position control system

A simple position control system only needs two sets of position pulse command signals, drive enable signal, prohibited drive signal, servo ready and servo alarm output signals. The wiring diagram of the simple system is shown as below.

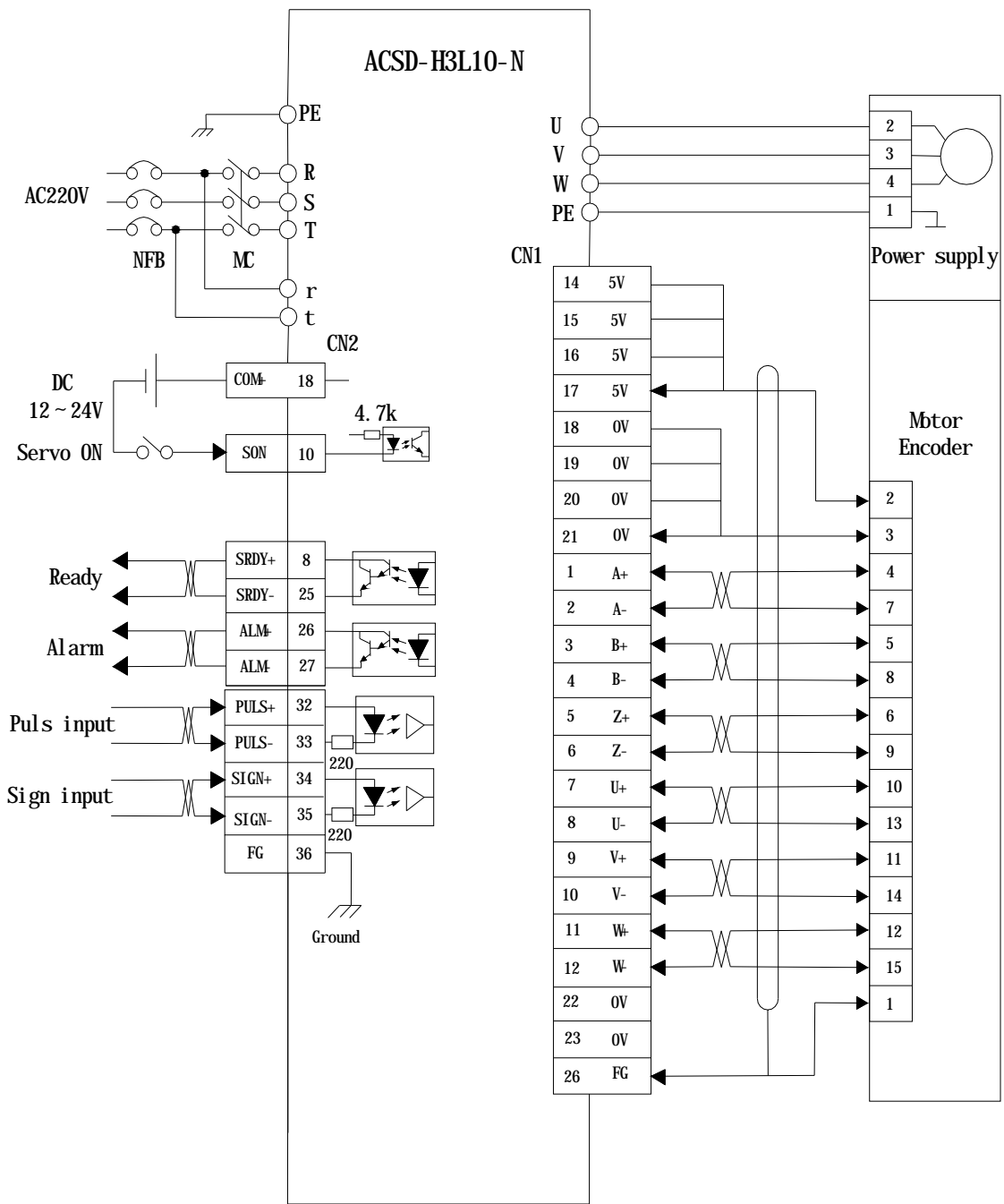

Figure 5.3 wiring diagram for the simple position control system

Note: Refer to the section 3.6.1, you could find the detailed wiring diagram for the position control system.

5.2.2 Parameters for the position control

Table 5.3 Parameters about the position control mode

Parameter NO.	Name	Value range	default	units
PA04	Control mode	0	0	
PA09	Proportional Position Loop Gain	0~1000	50	Hz
PA10	Position Feed Forward Gain	0~100	0	%
PA11	Smooth Constant of PA10	1~1000	0	ms
PA12	Electronic Gear Ratio (Numerator) N1	1~32767	1	
PA13	Electronic Gear Ratio (Denominator) M1	1~32767	1	
PA14	External Pulse Input Type	0~2	0	
PA15	Direction of External Pulse	0~1	0	
PA16	Positioning Completed Width	0~30000	20	
PA17	Excessive Position Error Range	0~30000	400	100 pulse
PA18	Excessive Position Error Function Selection	0~1	0	
PA19	Smooth Constant of Position Command	0~30000	0	0.1mS
PA20	Inhibit Drive Function Selection	0~1	0	
PA51	Dynamic Electronic Gear Function Selection	0~1	0	
PA52	Electronic Gear Ratio (Numerator) N2	1~32767	1	
PA53	Digital Input Terminals Function Selection / Enabled Word 1	0000~1111	0000	

1. External pulse input type

Table 5.4 Type and waveform of the external input pulse

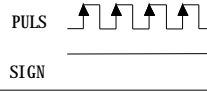
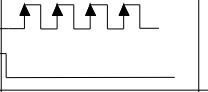
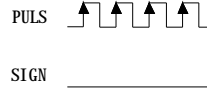
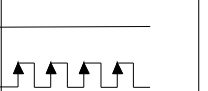
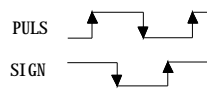
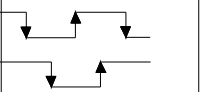
Pulse Type	Forward	Reverse	PA14
Pulse + Direction			0
CCW + CW			1
AB Phase Pulse			2

Host controller could drive the servo drive and motor running and positioning by external pulse. Referring to parameter PA14, you could see there are three types of the pulse. In the table 5.5 the types of the pulse are diagramed and the pulse edge indicated by arrows could be counted by drive in each pulse type.

You could change the direction of the pulse count by setting parameter PA15.

The pins 32 (PULSE+), 33 (PULSE-), 34(SIGN+), 35 (SIGN-) of the terminal interface CN2 are set for external pulses input. For the details of the interface CN2, please refer to the section 3.43.

2. Filter for position control

The filter is for the position smoothing of motion command. Using filter not only can improve the performance when servo motor accelerate or decelerate but also can make motor to operate more smoothly. When the load is change, the motor usually run not smoothly when starts to run and stop due to the friction and inertia change. At this moment, users can increase the value of the PA19 to improve the performance. But if the value is too large, the command delay phenomenon would be more obvious. When the parameter PA19=0, the filter is disable. The value of the PA19 is the time that the frequency of the position command increase from 0% to 63% of the external pulse frequency. Diagram of the filter is shown as below. (The non-filtering and the filtering waveform are contrasted.)

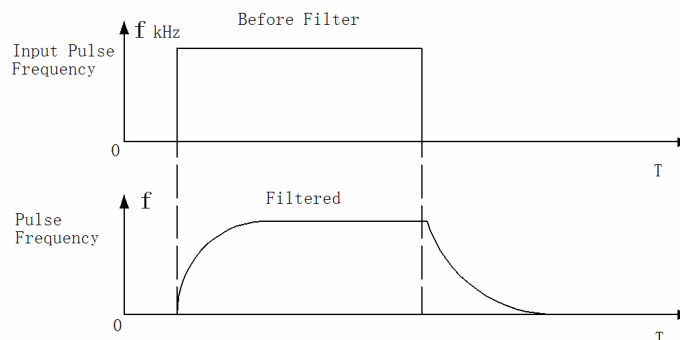

Figure 5.4 Diagram for comparison between the filtering and non-filtering waveform

5.2.3 Electronic gear ratio

Mechanical transmission ratio and the pulses per circle of the servo motor encoder couldn't be identified by the host controller. But the unit pulse generated by host controller could be corresponded to the actual moving distance by setting the electronic gear ratio.

Electronic gear ratio of the servo system could be calculated as the following.

- N1: Numerator of the electronic gear ratio (PA12)
- M1: Denominator of the electronic gear ratio (PA13)
- P1: Number of pulses corresponding to 1mm in the host controller
- F2: Number of encoder pulses per circle
- S1: Screw pitch of the mechanical transmission (mm)
- F1: Number of pulses required by actual moving distance 1mm.

$$F1=N1*P1/M1 \quad (\text{pulses / mm})$$

$$F1=F2/S1 \quad (\text{pulses / mm}) \text{ for actual moving distance without gearbox}$$

Therefore the electronic gear ratio $N1/M1$ is equal to $F2/(S1*P1)$.

For example, if $P1$ of the host is 1000 pulses/mm, $F2$ of the H series servo drive is 10000, $S1$ of the screw is 6mm, the electronic gear ratio $N1/M1=10000/(1000*6)=5/3$. So you could set the parameter $PA12 (N1)=5$ and the $PA13 (M1)=3$.

If there is a gearbox between screw and motor, the ratio of the gearbox is $N2/M2$;

$N2$: rotation number of the motor

$M2$: rotation number of the screw

$$F1=N1*P1/M1 \quad (\text{pulses / mm}) \text{ for host controller}$$

$$F1=F2*N2/(S1*M2) \quad (\text{pulses / mm}) \text{ for actual moving distance with gearbox}$$

Therefore the electronic gear ratio $N1/M1$ is equal to $F2*N2/(S1*P1*M2)$.

For the above-mentioned example, if the ratio of the gearbox is $N2/M2=5/3$. According to the formula, the electronic gear ratio $N1/M1=10000*5/(1000*6*3)=25/9$. So you should set the parameter $PA12 (N1)=25$ and the $PA13 (M1)=9$ for the mechanical transmission system with a gearbox.

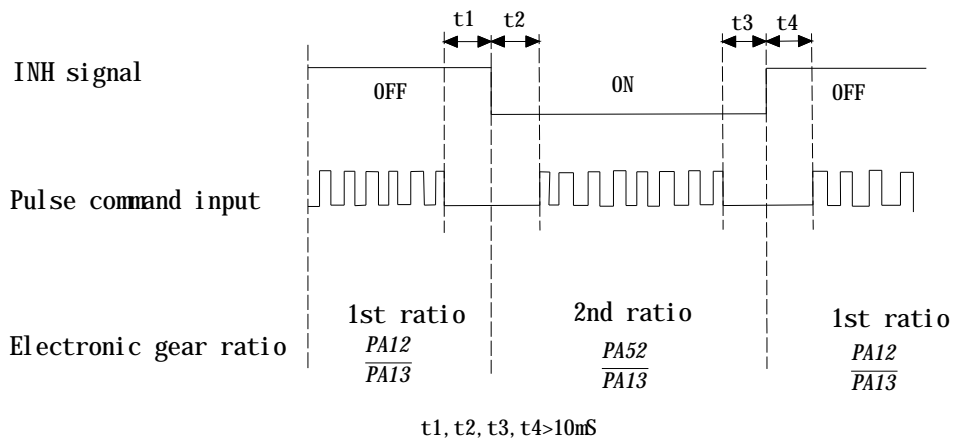

Figure 5.5 Diagram for dynamic electronic gear ratio

Note: H series servo drive provides two sets of dynamic electronic gear ratio, which could be switched online. The second numerator of the electronic gear ratio is set in the parameter PA 52, and denominator is the same as the one of the first one. When the PA51 is equal to 1, the function of the dynamic electronic gear is enabled and signal connected to pin-15 of the I/O interface CN2 could control the switching of the electronic gear. When the level of the signal is low, the servo drive would choose the second electronic gear ratio PA52/PA13.

5.2.4 Position proportional gain

The positional control loop includes the speed control loop, therefore you should complete the speed control setting first by using manual mode before performing position control (setting position control block diagram). Then adjust the proportional position loop gain PA09 and position feed forward gain PA10.

Table 5.5 The parameters about the position proportional gain

Parameter NO.	Name	Description	Value range	Defaults
PA-09	Position loop proportional gain	Increasing the value can improve the response frequency of the position	0~1000	50
PA-10	Position feed forward gain	Increasing the value can reduce the position track error	0~100	0
PA-11	Smooth constant of PA10	Be smoother to decrease the position overshoot	0~1000	0

For the positional control loop includes the speed control loop, the position loop bandwidth would be restricted by the one of the speed loop. It is recommended that the speed loop responsiveness should be at least four times faster than the position loop responsiveness. This means that the setting value of the proportional speed loop gain PA05 should be at least four times faster than proportional position loop gain PA09. The equation is shown as following:

$f_p \leq f_v / 4$, f_v : speed loop responsiveness (Hz) , f_p : position loop responsiveness (Hz)

$$PA09 = 2 * \pi * f_p$$

For example, the desired position loop responsiveness is equal to 40 Hz.

$$\text{Then } PA09 = 2 * \pi * 40 = 251 \text{ rad/s}$$

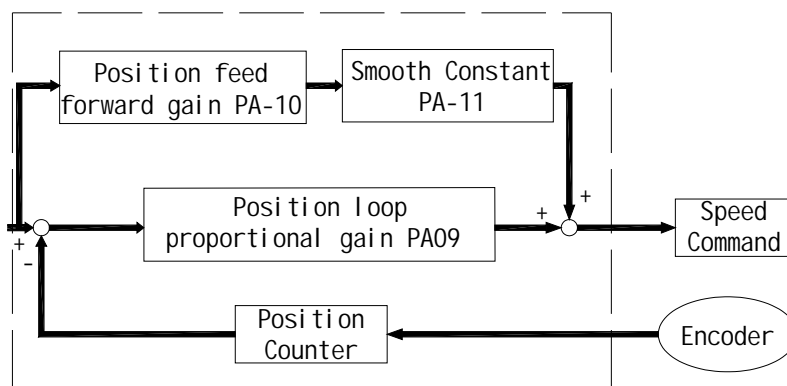

Figure 5.6 Flowchart of the position control loop

Increasing the position proportional gain can improve the stiffness of the system, expedite position loop response and reduce position error. However, if the setting value is over high, it may generate vibration or noise.

When the value of proportional position loop gain is too great, the position loop responsiveness will be increased and it will result in small phase margin. If this happens, the rotor of motor will oscillate. At this time, you have to decrease the value of the PA09 until the rotor stop oscillating. When there is an external torque command interrupted, over low PA09 value will let the motor cannot overcome the external strength and fail to meet the requirement of reasonable position track error demand. Adjust feed forward gain PA10 to efficiently reduce the dynamic position track error.

5.5 Gain Adjustment

The position and speed frequency response selection is depending on and determined by the control stiffness of machinery and conditions of applications. Generally, high responsiveness is essential for the high frequency positioning control of mechanical facilities and the applications of high precision process system. However, the higher frequency response may easily result in the resonance of machinery system. Therefore, for the applications of high frequency response, the machinery system with control stiffness is needed to void the resonance. Especially when adjusting the frequency response of unfamiliar machinery system, you could gradually increase the gain setting value to improve frequency response until the resonance occurs, and then decrease the gain setting value.

There are three control loop in the servo drive system, including the outermost position control loop, the intermediate speed control loop and the innermost current control loop. The flowchart for the servo system is shown as below.

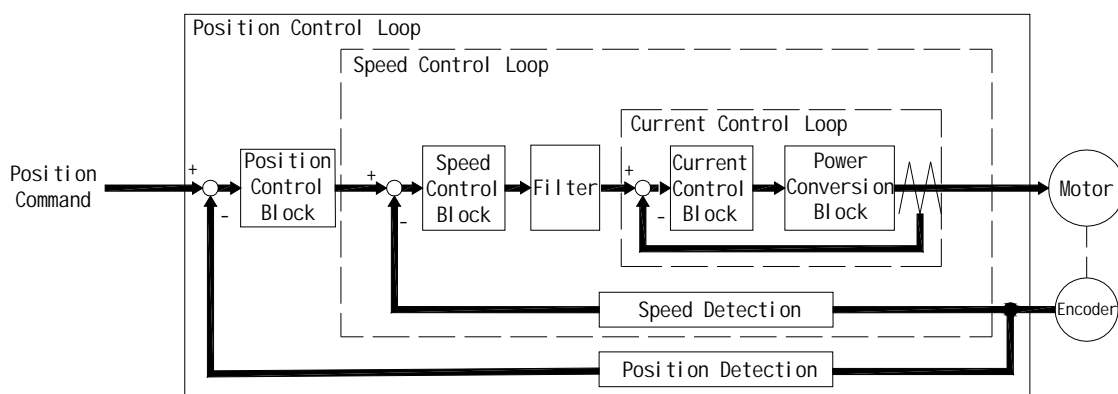

Figure 5.7 Diagram for the servo closed-loop control system

The responsiveness of the inner control loop should be greater than the outer control loop, otherwise the control system will be unstable, generating vibration or noise.

Therefore the value of the gain for the three control loop should be set correctly. Generally, the value of the current control loop gain should be the maximum and the one of the position control loop is the minimum.

The responsiveness of the current control loop which couldn't be change by the customers is set automatically within the system. And then the users should set the values of the speed and position control loop gain properly, avoiding that the inside and outside responsiveness are not matched.

5.5.1 Steps for gain adjustment

In order to obtain a stable system, please do not make major alteration at only one parameter related to the control loop. when one parameter is modified, some other relevant parameters should also be adjusted further to achieve the best results.

Therefore to modify the parameters related to the control loop, we follow the following steps.

Table 5.6 The basic rule for modifying the closed-loop parameters

	Reduce vibration or overshoot	Increase responsiveness
Step 1	Decrease the proportional position control loop gain PA09	Increase the proportional speed control loop gain PA09
Step 2	Increase the integral time of the speed control loop PA06	Decrease the integral time of the speed control loop PA06
Step 3	Decrease the proportional speed control loop gain PA05	Increase the proportional position control loop gain PA09

5.5.2 Adjustment for speed control loop

If the inertia of the machinery and conditions of applications is larger, you could adjust the relative parameters as the following step.

Step 1: Increase the integral time of the speed control loop PA06

Step 2: Gradually increase the value of the proportional speed control loop gain PA05 setting until the resonance occurs, and then decrease the gain setting value.

Step 3: Gradually decrease the integral time of the speed control loop PA06 until the resonance occurs, and then increase the setting value.

Step 4: If the resonance occurs, as a result the ideal responsiveness of the system could not be achieved. For this case, you could adjust the value of the low-pass filter for torque PA07 to suppress the resonance. And then you could repeat the above steps, in order to achieve a better responsiveness for the position and speed control loop.

5.5.3 Adjustment for position control loop

If the inertia of the machinery and conditions of applications is larger or the resonance occurs,

you could adjust the relative parameters as the following step.

Step 1: Increase the integral time of the speed control loop PA06

Step 2: Gradually increase the value of the proportional speed control loop gain PA05 setting until the resonance occurs, and then decrease the gain setting value.

Step 3: Gradually decrease the integral time of the speed control loop PA06 until the resonance occurs, and then increase the setting value.

Step 4: Gradually increase the value of the proportional position control loop gain PA09 setting until the resonance occurs, and then decrease the gain setting value.

Step 5: For achieving better track error of the position control loop, users could adjust position feed forward gain PA10 and PA11 (the smooth constant of feed forward gain) appropriately.

Step 6: If the resonance occurs, as a result the ideal responsiveness of the system could not be achieved. For this case, you could adjust the value of the low-pass filter for torque PA07 to suppress the resonance. And then you could repeat the above steps, in order to achieve a better responsiveness for the position and speed control loop.

5.6 Electromagnetic Brake

When the servo drive is operating, if the digital output BRK is set to off, it indicates that the electromagnetic brake is disabled and motor is stop running and locked. If the digital output BRK is set to ON, it indicates electromagnetic brake is enabled and motor can run freely. The electromagnetic brake is usually used in perpendicular axis (Z-axis) direction to reduce the large energy generated from servo motor. Using electromagnetic brake can avoid the load may slip since there is no motor holding torque when power is off. Without using electromagnetic brake may reduce the life of servo motor.

To avoid malfunction, the electromagnetic brake should be activated after servo system is off.

5.6.1 Parameters about electromagnetic brake

The on delay time of the electromagnetic brake is set within the servo drive, except this there are three parameters about the off delay time (speed) of the electromagnetic brake. The users can use these three parameters to set the off delay time of electromagnetic brake.

Table 5.7 Parameters about the electromagnetic brake

Parameter NO.	Name	Value range	Defaults	Units
PA47	On delay time of electromagnetic brake when motor is still	0~200	0	10ms
PA48	Off delay time of electromagnetic brake when motor is running	0~200	50	10ms
PA49	Off speed of the motor for electromagnetic brake when the motor is running.	0~3000	100	r/min

5.6.2 Matters for electromagnetic brake

Wiring of the electromagnetic brake is shown as below:

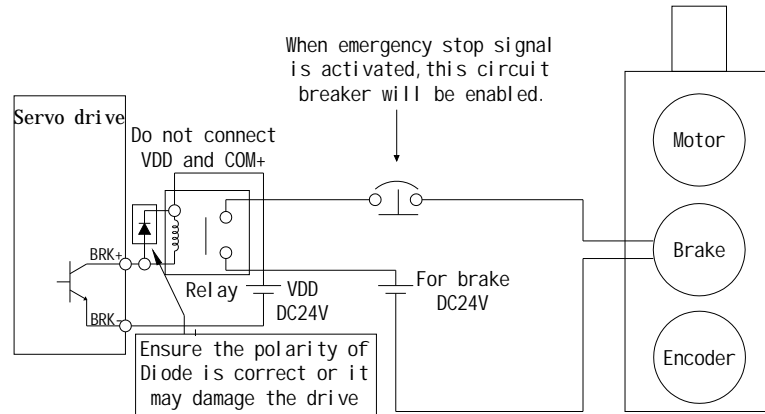

Figure 5.8 Diagram for electromagnetic brake

The BRK signal is used to control the brake operation. The VDD DC24V power supply supplied externally should be used to power the relay coil. When BRK is on, the motor brake will be activated. The coil of the brake has no polarity. But the diode has polarity, please ensure the polarity of the diode is correct or it may damage the drive. At last the power supply for brake is DC24V. Never use it for VDD, the +24V source voltage.

Timing chart for using servo motor with electromagnetic brake:

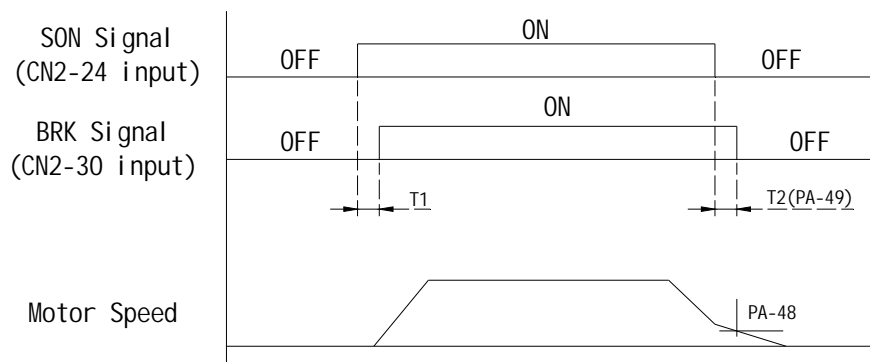

Figure 5.9 Timing chart for electromagnetic brake

BRK output timing explanation:

1. when servo off (when DI SON is not activated), the BRK output goes off (electromagnetic brake is locked) after the delay time set by PA48 is reached and the motor speed is still higher than the setting value of PA49.
2. when servo off (when DI SON is not activated), the BRK output goes off (electromagnetic brake is locked) if the delay time set by PA48 is not reached but the motor speed is still lower than the setting value of PA49.

5.7 Timing

5.7.1 Timing for power on

Step 1. Control power supply should be turned on earlier than the main power, or turned on simultaneously.

Step 2. Delay 1.2s after the main power turn on, the servo ready (SRDY) will be ON. And then the servo drive could receive the enable signal (SON) from the host controller. When the servo drive is enabled, the main circuit will work and the motor will run. If the drive couldn't receive the SON signal or detect some error, the main circuit will be disabled and the motor will be at zero-speed status.

Step 3. As the cautions, please do not restart frequently.

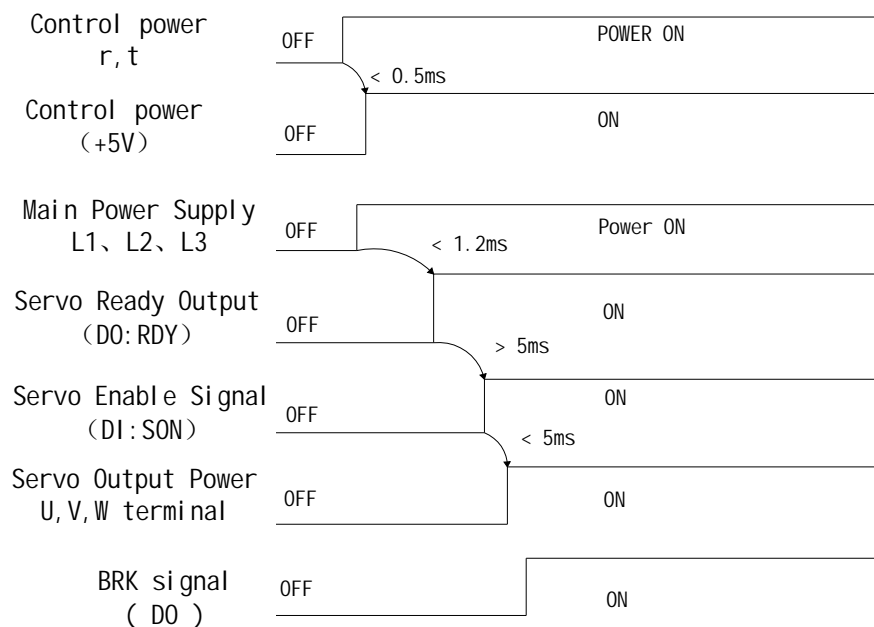

Figure 5.10 Timing flowchart about drive power on

Note: Even if the host controller output the SON signal before the SRDY signal of the drive, the servo drive couldn't receive the SON until the SRDY signal is ON for 5 msec.

5.7.2 Timing for enable operation

1. Enable operation timing for still motor

When the motor is still, if the SON is OFF, the main circuit will work and the work will not be powered off for some time to hold the position until the electromagnet brake is disabled for some time set by PA47.

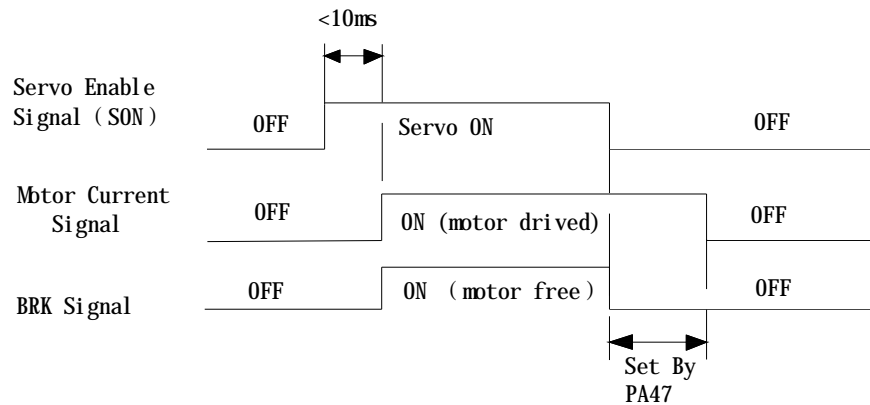

Figure 5.11 Enable operation timing flowchart when motor is still

2. Enable operation timing when the motor is running

When the motor is running, if the SON turn off, the main circuit of the drive will be disabled and the motor will be powered off. The electromagnetic brake will still be ON for some delay time set by PA48 or PA49, while the motor could be slow down, avoiding to damage the brake at the high speed. The delay time would be selected the one which is samer between the time set by PA48 and the time motor slow down to the target speed.

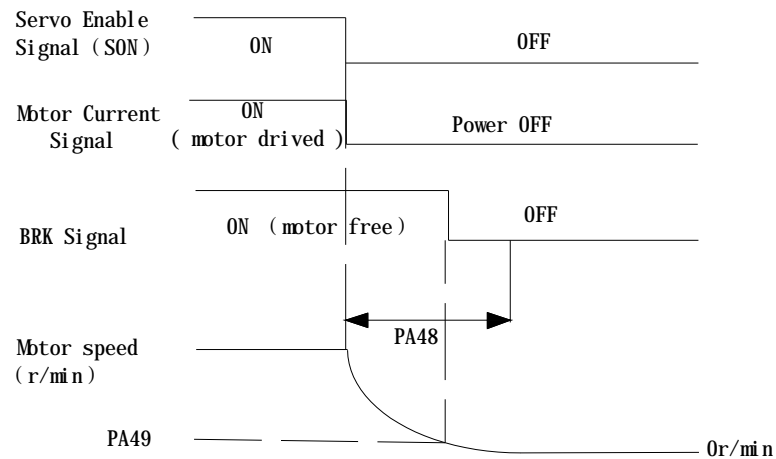

Figure 5.12 Disable operation timing flowchart when motor is running

5.7.3 Timing for alarm

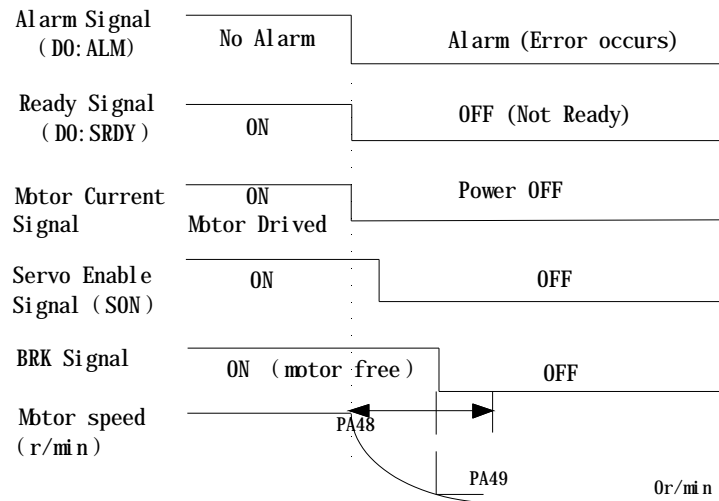

Figure 5.13 Alarm timing flowchart when motor is running or still

5.8 Start-stop characteristics

The start-stop characteristics of the servo system is determined by many aspects, such as the load inertia, the characteristics of the drive and motor, and the on-off frequency.

5.8.1 On-off frequency and load inertia

When the servo drive and motor is used in the applications which needs high on-off frequency, please confirm whether the frequency is in the permissible range of “H” series servo drive in advance. The frequency range is determined by the motor, the load inertia and the speed of the motor. To determine the frequency range, you could refer to the following table:

Table 5.8 On-off frequency VS Load inertia

Inertia multiples	On-off frequency and ACC/DEC time
$J \leq 3J_{\text{motor}}$	$f > 100$ /min; less than 70mS
$J \leq 5J_{\text{motor}}$	$60 < f \leq 100$ /min; less than 130mS
$J > 5J_{\text{motor}}$	$f \leq 60$ /min; greater than 150mS

Note: The above table only gives the on-off frequency in the general case, the specific circumstances will vary with the motor type and the load condition.

5.8.2 Adjustment

When the load inertia is at least five times greater than the motor inertia, some error will occur, such as position overshoot, excessive position deviation and speed response fault etc.

If the above situation occurs, you could adjust the relative parameters as the following.

Step 1: Increase the value of PA05 and PA06

Step 2: Decrease the value of PA09.

Step 3: Increase the value of the parameter PA40, PA41 and PA42. (ACC/DEC time constant)

Step 4. Increase the ACC/DEC time constant of the host controller.

On the other hand, you could select a motor which has larger inertia instead of the using motor.

Chapter 6 Parameters

6.1 Parameter summary

The defaults of the following table is shown as an example of the “H” series drive, the value of the parameters marked “*” may be different from other types. In the table, applicable mode means that the parameter can play a role in a certain control mode: P refers to position control mode, S refers to speed control mode, T refers to torque control mode and ALL refers to all of the control mode.

Table 6.1 Parameter List

No.	Function Description	Applicable Mode	Range	Default	Unit
PA-0	Password	ALL	0-1000	315*	
PA-1	Motor Code	ALL	0~100	35	
PA-2	Version	ALL	0~999	*	
PA-3	Monitor Status	ALL	0~19	0	
PA-4	Control Mode	ALL	0~5	0	
PA-5	Proportional Speed Loop Gain	P, S	5~2000	165*	Hz
PA-6	Speed Integral Time	P, S	1~1000	30*	ms
PA-7	Low-pass Filter for Torque	ALL	1~1000	10	0.1ms
PA-8	Speed Detection Filter	ALL	1~1000	10	0.1ms
PA-9	Proportional Position Loop Gain	P	1~1000	50	Hz
PA-10	Position Feed Forward Gain	P	0~100	0	%
PA-11	Smooth Constant of PA10	P	1~1000	0	ms
PA-12	Electronic Gear Ratio (Numerator) N1	P	1~32767	1	
PA-13	Electronic Gear Ratio (Denominator) M1	P	1~32767	1	
PA-14	External Pulse Input Type	P	0~2	1	
PA-15	Direction of External Pulse	P	0~1	0	
PA-16	Positioning Completed Width	P	0~30000	20	pulse
PA-17	Excessive Position Error Range	P	0~30000	400	×100 pulse
PA-18	Excessive Position Error Function Selection	P	0~1	0	
PA-19	Smooth Constant of Position Command	P	0~30000	0	0.1mS
PA-20	Inhibit Drive Function Selection	ALL	0~1	1	
PA-21	JOG Operation Speed	S	-3000~3000	120	r/min
PA-22	Speed Command selection	S	0~1	1	
PA-23	Alarm Enabled Status Setting	ALL	0~1000	200	
PA-24	1st Speed Command	S	-3000~3000	0	r/min
PA-25	2nd Speed Command	S	-3000~3000	100	r/min
PA-26	3rd Speed Command	S	-3000~3000	300	r/min
PA-27	4th Speed Command	S	-3000~3000	-100	r/min
PA-28	Target Motor Speed	S	0~3000	500	r/min
PA-29	Analog Torque Command Gain	T	10~100	50	0.1V/100%

PA-30	Reserved	ALL		167	
PA-31	Pulse Logic Function Selection	P	1~5000	167	
PA-32	Reserved			167	
PA-33	Direction of Torque Command	T	0~1	0	
PA-34	Internal CCW Torque Command Limit	ALL	0~200	200*	%
PA-35	Internal CW Torque Command Limit	ALL	-200~0	-200*	%
PA-36	External CCW Torque Command Limit	ALL	0~200	100	%
PA-37	External CW Torque Command Limit	S	-200~0	-100	%
PA-38	Torque Command Limit for JOG and Trial Run	JOG, Sr	0~300	100	%
PA-39	Zero-offset Compensation for Torque Command	S	-2000~2000	0	
PA-40	Acceleration Time	S	1~10000	0	mS
PA-41	Deceleration Time	S	1~10000	0	mS
PA-42	Accel/Decel S-curve	S	1~1000	0	mS
PA-43	Analog Speed Command Gain	S	10~3000	300	(r/min)/V
PA-44	Direction of Speed Command	S	0~1	0	
PA-45	Zero-offset Compensation for Analog Speed Command	S	-5000~5000	0	
PA-46	Low-pass Filter for Speed Command	S	0~1000	3	mS
PA-47	On Delay Time of Electromagnetic Brake when motor is stopped	ALL	0~200	0	×10mS
PA-48	Off Delay Time of Electromagnetic Brake when motor is running	ALL	0~200	50	×10mS
PA-49	Target Speed for Opening Electromagnetic Brake	ALL	0~3000	100	r/min
PA-50	Sampling Gain for Bus Voltage	ALL	0~1000	506	
PA-51	Dynamic Electronic Gear Function Selection	P	0~1	0	
PA-52	Electronic Gear Ratio (Numerator) N2	P	1~32767	1	
PA-53	Digital Input Terminals Function Selection / Enabled Word 1	ALL	0000~1111	0	
PA-54	Digital Input Terminals Function Selection / Enabled Word 2	ALL	0000~1111	0	
PA-55	Current Sampling Gain	ALL	0~1000	312	
PA-56	Reserved	ALL		0	
PA-57	Reserved	ALL	0~255	0	
PA-58	Input Terminal Delay Time	ALL	1~1000	2	mS

6.2 Detailed parameter setting

Table 6.2 Detailed settings for the parameter

NO.	Name	Function description	Value range
0	Password	①Generally prevent some parameters modified falsely. If you need to modify the parameters, you need to modify this parameter to the password first. ②Password for general parameters is 315 ③Password for PA1 is 302	0~1000
1	Motor Code	The value should be adapted for the motor you used Refer to section 6.3 for specific value and password is 302	0~1000
2	Version	View the software version which couldn't be modified	0~999
3	Initial Monitor	Monitoring variables for the initial display when the drive powered on. 0: Feedback speed; 1: Low data of the feedback position 2: High data of the feedback position 3: Low data of the position command 4: High data of the position command 5: Low data of the position error 6: High data of the position error 7: Feedback torque 8: Feedback current; 9: Reserved 10: Present control mode; 11: Input frequency of pulse command 12: Speed command (Integrated) 13: Torque command (Integrated) 14: Motor feedback-current position. 15: Reserved 16: Reserved 17: Voltage of the DC bus 18: Drive status; 19: Error code;	0~19
4	Control Mode	Variables for the control mode 0: Position control mode 1: Speed control mode. 2: Torque control mode 3: Speed trial run control mode 4: JOG control mode 5: Control mode for adjusting the zero of the encoder	0~5
5	Proportional Speed Loop Gain	The stiffness and responsiveness of the speed control loop is determined by the proportional speed gain and integral time. The default value is 170. Generally if the load inertia is greater, the value should be modified larger. You could increase the value until the resonance or noise occurs and then decrease the value.	5~2000 Hz

6	Integral Time of Speed Control Loop	The value of the integral time has an effect on the stiffness and responsiveness of the speed control loop. If the value is too small, overshoot would occur. While the value is too large, the response would be slow. Generally, the value should be modified according to the load inertia. Larger inertia needs larger integral time.	1~1000 mS
7	Low-pass Filter for Torque	Time constant for torque low-pass filter has an effect on the responsiveness of the torque control. The function of this parameter is to restrain resonance. Increasing the value will decrease the cutoff frequency resulted in the smaller noise and vibration but lower response. If the inertia of the load is large, you could increase the value to restrain the resonance.	1~1000 ×0.1mS
8	Speed Detection Filter	Time constant of the speed detection filter has an effect on the stiffness and responsiveness of the speed control loop. Increasing the value will decrease the cutoff frequency resulted in the smaller noise. If the value is too large, the response will be slow and the vibration or resonance will occur. Generally, the value should be modified according to the load inertia.	1~1000 ×0.1mS
9	Proportional Position Loop Gain	Proportional gain of the position control loop has an effect on the stiffness and responsiveness of the control loop. Increasing the value can improve the response frequency of the position. Increasing the value will increase the stiffness and decrease the position offset when the position frequency is the same. If the value is too large, the vibration or resonance will occur.	1~1000/S
10	Position Feed Forward Gain	Increasing the value can reduce the position track error. 100% means that the track error may be zero at any position frequency. If the value is too large, the vibration or resonance will occur. Generally the value is 0, excepting high responsive required by the application condition.	0~100%
11	Smooth Constant for PA10	The value is the time constant of the low-pass filter for position feed forward gain. Be smoother to decrease the position overshoot.	1~1000ms
12	Electronic Gear Ratio (Numerator) N1	Electronic gear ratio of the servo system could match the position command of the host controller and the actual distance motor running. The electronic gear ratio can be calculated as the following : $N1/M1 = F2/(S1 \cdot P1)$ P1: Number of pulses corresponding to 1mm in the host controller F2: Number of encoder pulses per circle (Default is 10000) S1: Screw pitch of the mechanical transmission (mm) The ideal range of the gear ratio is from 1/50 to 50.	1~32767
13	Electronic	Refer to parameter PA12	1~32767

	Gear Ratio (Denominator) M1		
14	External Pulse Input Type	There are three inputting type kinds for external pulse: 0: pulse + direction. 1: CCW pulse + CW pulse. 2: AB phase pulse.	0~2
15	External Pulse Direction	0: Normal direction 1: Negative direction	0~1
16	Positioning Completed Width	The value is the position error range to judge whether the positioning is completed or not. In the position control mode, the COIN signal will be on when the value of the position error is less then the value of the PA16. In other control mode, the COIN signal will be ON when the speed reaches the target speed command.	0~30000 pluse
17	Excessive Position Error Range	The value is the detection range for error 4. In the position control mode, if the position error is larger than the value of PA17, the servo drive will be disabled and the error code would be displayed.	0~30000 ×100 pluse
18	Excessive Position Error Function Selection	0: Enable detection function for excesive position error. 1: Disable the function for detecting the position error.	0~1
19	Smooth Constant of Position Command	Smooth the position command by exponential deceleration, the value of PA19 is the time contant for the exponential deceleration. The pulse would not be lost but the position command may be delay. You could use the function at the following conditon. <ul style="list-style-type: none"> • The host controller does not have a deceleration / acceleration function. • The electronic gear ratio is larger than 10. • The position frequency is low. ; • Stepping jump and vibration occurs when the motor is running. The function will be disabled when the value is 0.	0~30000 ×0.1mS
20	Inhibition Function Selection	0: Enable the inhibition function, and the FSTP signal is effective. If the CCW FSTP signal is ON, the drive could be drived in CCW direction. If the signal is OFF, the drive could not be drive in the CCW direction. It's the same to CW FSTP signal. When both of the FSTP signals are OFF, the drive will be disabled. 1: Disable the inhibition function. The motor could run free without FSTP signals.	0~1
21	JOG Operation Command	Set the operation speed command for JOG control mode.	-3000~3000 r/min
22	Speed Command selection	0: choose the internal value of the speed as the command. You could choose different inside value as the command by setting SC1 and SC2. SC1 OFF, SC2 OFF: Internal speed command 1	0~1

		<p>SC1 ON, SC2 OFF: Internal speed command 2</p> <p>SC1 OFF, SC2 ON: Internal speed command 3</p> <p>SC1 ON, SC2 ON: Internal speed command 4</p> <p>1: choose the analog signal as the source of the speed command.</p>	
23	Alarm level selection	If PA23=200, the Alarm signal will be ON when error occurs. If PA23≠200, the signal will be OFF when error occurs.	0~3000
24	1st Speed Command	When PA4=1 and PA22=0, the value of the parameter PA24 is the source of the speed command if SC1 and SC2 are OFF.	-3000~3000r/min
25	2nd Speed Command	When PA4=1 and PA22=0, the value of the parameter PA24 is the source of the speed command if SC1 is ON and SC2 is OFF.	-3000~3000r/min
26	3rd Speed Command	When PA4=1 and PA22=0, the value of the parameter PA24 is the source of the speed command if SC1 is OFF and SC2 is ON.	-3000~3000r/min
27	4th Speed Command	When PA4=1 and PA22=0, the value of the parameter PA24 is the source of the speed command if SC1 and SC2 are ON.	-3000~3000r/min
28	Target Motor Speed	Set the speed-reached value. In all control mode excepting position control mode, if the motor feedback speed is larger than the value of the parameter, the SCMP signal would be ON, otherwise SCMP would be OFF.	0~3000 r/min
29	Analog Torque Command Gain	Set the proportional relationship between analog input voltage and the value of torque command. Only in the torque control mode, the function is effective. The unit is 0.1V/100%. The default is 30, which means that the value of the torque command would be set to 100% rate torque when the value of the voltage is 3V.	10~100 (0.1V/100%)
30	Reserved		
31	Pulse Logic Function Selection	When the value of the parameter is 167, the input circuit logic is positive logic. Otherwise if PA31=179, the logic would be negative.	
32	Reserved		
33	Direction of Torque Command	<p>0: The direction of the torque is CCW when analog voltage is bigger than 0.</p> <p>1: The direction of the torque is CW when analog voltage is bigger than 0.</p>	0~1
34	Internal CCW Torque Command Limit	The value of the parameter set in the drive is the maximum torque provided by the motor in CCW direction. It's effective in all control mode, and the defaults is 200%.	0~300%
35	Internal CW Torque Command Limit	The value of the parameter set in the drive is the maximum torque provided by the motor in CW direction. It's effective in all control mode, and the defaults is 200%.	-300~0%
36	External CCW Torque Command Limit	The value is the maximum torque provided by the motor in CCW direction. The function could be enabled by pin-16 (FIL) of terminal CN2. When FIL is on, the function of PA36 is effective. Otherwise the torque of the motor could not be limited in CCW direction by PA36.	0~300%

37	External CW Torque Command Limit	The value is the maximum torque provided by the motor in CW direction. The function could be enabled by pin-17 (RIL) of terminal CN2. When FIL is on, the function of PA36 is effective. Otherwise the torque of the motor could not be limited in CCW direction by PA37.	-300~0%
38	Torque Command Limit for JOG and Trial Run	The value is the maximum torque provided by the motor when the operation mode is JOG. The function of internal or external torque limit is effective at the same time.	0~300%
39	Zero-offset Compensation for Torque Command	The value is the bias compensation for the analog signal of torque command.	-2000~2000
40	Acceleration Time	The value is the acceleration time for motor from 0 to 1000r/min and the process is linear. The function is effective only in speed control mode.	1~10000 mS
41	Deceleration Time	The value is the deceleration time for motor from 0 to -1000r/min and the process is linear. The function is effective only in speed control mode.	1~10000 mS
42	Accel/Decel S-curve	S-curve filter is for the speed smoothing of motion command. The value is the acceleration or deceleration time for the S-curve.	1~10000 mS
43	Analog Speed Command Gain	Set the proportional relationship between analog input voltage and the speed command. Only when PA4=1 and PA22=1, the function is effective. The unit is r/(min*V). The default is 300, which means that the value of the speed command would be set to 3000r/min when the value of the voltage is 10V.	10~3000 r/min/V
44	Direction of Speed Command	Select the direction for the external speed command. 0: When the voltage of the external speed command is positive, the speed direction is CCW. 1: When the voltage of the external speed command is positive, the speed direction is CW.	0~1
45	Zero-offset Compensation for Analog Speed Command	The value is the bias compensation for the analog signal of speed command.	-2000~2000
46	Low-pass Filter for Speed Command	The value is the time constant of the low-pass filter for the analog speed command. The value is larger, the responsiveness is slower and thenosie is smaller. And then if the value is smaller, the responsiveness would be faster and the nosie may be larger. The function is effective only in the following conditions. 1. PA4=4 and PA22=1. 2. PA4=2.	0~1000ms
47	On Delay Time of Electromagnetic Brake	The value is the delay time for the electromagnetic brake turning on.	0~200 ×10mS
48	Off Delay Time of	The value is the delay time for the electromagnetic brake turning off.	0~200 ×10mS

	Electromagnetic Brake										
49	Target Speed for Turning off Electromagnetic Brake	When the motor is running, if the servo on signal turn off or error occurs, the BRK signal will turn off when the feedback speed is slower than the value of the parameter. The actual delay time is chosen between PA48 and the operation time of PA49.	0~3000 r/min								
50	Sampling Gain for Bus Voltage	The value is the linear gain for DC Bus voltage sampling signal. The value is prohibited to be modified.									
51	Dynamic Electronic Gear Function Selection	0: the function is disabled. 1: the function is effective. And the servo will choose PA12/PA13 as the electronic gear ratio when INH is Off, but when INH is on, PA52/PA13 would be chosen.	0~1								
52	Electronic Gear Ratio (Numerator) N2	The value is the numerator of the 2nd electronic gear ratio. And the denominator of the both electronic gear ratios is the same.	1~32767								
53	Digital Input Terminals Function Selection Enabled Word 1	Enable the function of the external signal. The value 1 means the function is effective such as the function signal is ON. And the value 0 means the function is noneffective such as the signal is off. If the function is enabled by bit of PA53, the status of the signal would be noneffective. The PA53 is represented by a 4-digit binary number as the following. <table border="1" style="margin-left: 20px;"> <tr> <td>Bit 3</td> <td>Bit 2</td> <td>Bit 1</td> <td>Bit 0</td> </tr> <tr> <td>RSTP</td> <td>PSTP</td> <td>ALRS</td> <td>SON</td> </tr> </table> Bit 0 SON: Servo enable. (Pin-10 of CN2) Bit 1 ALRS: Alarm clear. (Pin-11 of CN2) Bit 2 FSTP: Forward software limit. (Pin-12 of CN2) Bit 3 RSTP: reverse software limit. (Pin-13 of CN2)	Bit 3	Bit 2	Bit 1	Bit 0	RSTP	PSTP	ALRS	SON	
Bit 3	Bit 2	Bit 1	Bit 0								
RSTP	PSTP	ALRS	SON								
54	Digital Input Terminals Function Selection or Enabled Word 2	It's the same as the PA53. If the function is enabled by bit of PA53, the status of the signal would be noneffective. The PA53 is represented by a 4-digit binary number as the following. <table border="1" style="margin-left: 20px;"> <tr> <td>Bit 3</td> <td>Bit 2</td> <td>Bit 1</td> <td>Bit 0</td> </tr> <tr> <td>RIL</td> <td>FIL</td> <td>1NH/SC2</td> <td>CLE/SC1/ZEROSPD</td> </tr> </table> Bit 0 CLE/SC1/ZEROSPD: Pin-14 of CN2 Bit 1 1NH/SC2: Pin-15 of CN2 Bit 2 FIL: Pin-16 of CN2 Bit 3 RIL: Pin-17 of CN2	Bit 3	Bit 2	Bit 1	Bit 0	RIL	FIL	1NH/SC2	CLE/SC1/ZEROSPD	0000~111
Bit 3	Bit 2	Bit 1	Bit 0								
RIL	FIL	1NH/SC2	CLE/SC1/ZEROSPD								
55	Current Sampling Gain	The value is the linear gain for output current sampling signal. The value is prohibited to be modified.	0~1000								
56	Reserved										
57	Reserved										
58	Input Terminal Delay Time	The time constant for anti-shaking function of the input terminal.	1~1000ms								

1.Code list of the AC Servo for adaptive motor

Code	Motor Model	Power (Kw)	Torque (N.m)	Rated speed (rpm)	Rated current (A)
22	60ST-M00630	0.2	0.64	3000	1.2
23	60ST-M01330	0.4	1.27	3000	2.8
24	60ST-M01930	0.6	1.91	3000	3.7
25	80ST-M01330	0.4	1.3	3000	2.6
26	80ST-M02430	0.75	2.4	3000	4.2
27	80ST-M03330	1	3.3	3000	4.2
30	MG80ST-M04025	1	4	2500	4.4
31	MG90ST-M02430	0.75	2.4	3000	3
32	MG90ST-M03520	0.75	3.5	2000	3
33	MG90ST-M04025	1	4	2500	4
34	110ST-M02030	0.6	2	3000	4
35	110ST-M04030	1.2	4	3000	5
36	110ST-M05030	1.5	5	3000	6
37	110ST-M06020	1.2	6	2000	6
38	110ST-M06030	1.8	6	3000	8
44	130ST-M04025	1.0	4	2500	4
45	130ST-M05025	1.3	5	2500	5
46	130ST-M06025	1.5	6	2500	6
47	130ST-M07720	1.6	7.7	2000	6
48	130ST-M07730	2.4	7.7	3000	9
49	130ST-M10015	1.5	10	1500	6
50	130ST-M10025	2.6	10	2500	10
51	130ST-M15015	2.3	15	1500	9.5
52	130ST-M12020	2.4	12	2000	10
Others	110ST-M04030	1.2	4	3000	5

NOTE:

1. The parameter for moter code is PA1.The default motor code is set for 110ST-M04030 by 35. If you need to change the motor code PA1,you should set PA0 to 302 firstly.Secondly set PA1 to the code for the motor which you use according to the list. At last you need to save the parameters that you change.(You can read the chapter 4 to know how to save the parameters).The parameter PA1 will take effect by restart.

2. Code 22, 23 and 24 are applied to Hirden 60ST series motor only. If your motor is not produced by Hirden,please refer to chapter 3.

3. There are two types of the rotate direction for the encoder of the servo motor.The default type of Hirden servo drive and motor is same as the Delta's.Please makesure the type of the rotate direction for your motor, or contact your local Hirden sales representative.

Chapter 7 Troubleshooting

If a fault is detected on the servo motor or drive, a corresponding fault code will be shown on the drive's LED display.

7.1 Fault messages table

Table 7.1 Fault messages

Display	Fault Name	Fault Description
Err - -	Normal	There is no error.
Err 1	Overspeed	Motor's control speed exceeds the limit of normal speed.
Err 2	Overvoltage	Max circuit voltage exceeds its maximum allowable value.
Err 3	Undervoltage	Max circuit voltage is below its minimum specified value.
Err 4	Excessive position deviation	Position control deviation value exceeds the limit of its allowable setting value.
Err 6	Speed loop amplifier saturation	The amplifier of the speed control loop is saturated for a long time, which has exceeded the specified value.
Err 7	Limit switch error	Forward or Reverse limit switch is activated
Err 8	Position counter overflow	Position counter overflow occurs.
Err 9	Encoder error	Pulse signal is in error.
Err 10	Power voltage is overhigh	Excessive voltage is applied to the input
Err 11	Current response fault	Current error has exceeded the specified value for a long time.
Err 12	Short circuit	Main circuit current is higher than 1.5 multiple of drive's instantaneous maximum current value.
Err 13	Drive temperature error	The temperature of drive is over high.
Err 14	Regeneration error	Regeneration control operation is in error.
Err 16	Instantaneous overload	The instantaneous current of the drive is overhigh.
Err 17	Speed response fault	Speed error has exceeded the specified value for a long time.
Err 19	Warm reset	Software warm global reset
Err 20	EE-PROM error	An error occurs when writing the current settings into EE-PROM.
Err 23	Current sensor adjustment	Adjusted value of the current sensor

	error	exceeds the limit of its allowable setting value when perform electrical adjustment.
Err 29	Overload for motor	Servo motor is overload.
Err 30	Pulse Z error	The pulse Z of the encoder is lost.
Err 32	U,V,W error	The wiring connections of U,V,W (for encoder interface) are in error
Err 34	OT	The ambient temperature is over high.
Err 35	UT	The ambient temperature is ultralow.
Err 36	Over curret	The main circuit current of the drive is higher than 2 multiple of the rated current.
Err 37	Instantaneous overload for motor	The instantaneous load of the motor is heavier than 1.5 multiple of motor's maximum load value..
Err 38	Motor temperature error	The motor is overload for a long time.
Err 5,15,21,22,25,26,27,28,31,33		Reserved

7.2 Potential Cause and Corrective Actions

“Err xx” would be shown on the display, when some error occurs (xx is the alarm code). Some errors are common, such as Err 3, Err 6, Err 9, Err 11, Err 13, Err 17 and Err 38, which may be caused by wiring or operation error.

Generally, you could restart the servo to clear the alarm and then the servo may work normally. But if after re-powering the error still exists or the alarm occurs frequently, you could refer to the following actions and if necessary you could contact your local Hirден sales representative.

Table 7.2 Corrective actions for trouble shooting

Code	Fault Name	Cause	Corrective Actions
Err01	Overspeed	Improper input instruction pulse	Check the pulse frequency and the electronic gear ratio
		The load inertia is too large.	Decrease the load inertia
			Increase the Accel/Decel time
		Encoder fault	Replace the motor
		Encoder cable fault	Replace the cable
The max. speed setting error	Modify or recover the parameter		
Err02	Overvoltage	Servo drive default	Replace the drive
		The power voltage is too high	Check the power supply.
		The power waveform is abnormal	
Err03	Undervoltage	Servo drive default	Replace the drive
		The power voltage is too low.	Check the power supply.
		Transformer capacity is not enough.	Replace the transformer by a larger one
		The cable is loose	Check and fix the cable
Err04	Excessive position deviation	Encoder fault	Replace the motor
		The rigidity is not enough	Increase the PA5 and PA9
		The output torque of motor is not enough.	Check the function for torque limit
			Decrease the load
		Replace the motor and drive.	
The pulse frequency is inapplicable	Decrease the frequency.		

Err06	Speed loop Amplifier saturation	The load is too large.	Decrease the load
			Replace the motor and servo
		The motor is stuck	Check the mechanical structure
		Motor fault	Replace the motor
Err07	Limit switch error	FSTP or RSTP is OFF	Check the digital input signal
		Inhibition function is enabled	Disable the function
Err08	Position counter overflow	The motor is stuck	Check the mechanical structure
		Pulse signal is abnormal	Check the pulse signal
Err09	Encoder error	Encoder fault	Replace the motor
		Encoder cable fault	Replace the cable
		The encoder cable is too long	Please shorten the cable or bold the core
Err10	Power voltage is overhigh	The voltage of the power supply is too high	Check the power source and ensure the voltage is normal.
Err11	Current response fault	Servo drive fault	Replace the servo drive
		Short-circuit between U, V and W	Check the wiring
		Poorly grounded	Confirm to be grounded normally
		Winding insulation of the motor is damaged	Replace the motor
Err12	Short circuit	Short-circuit between U, V and W	Check the wiring
		The load is too heavy	Replace the drive by a larger one
		Servo motor fault	Replace the motor
		Servo drive fault	Replace the drive
Err13	Drive temperature error	Run for a long time with overload	Decrease the load or choose a larger drive.
Err14	Regeneration error	Brake circuit fault	Replace the drive
		The capacity of regeneration system is not enough	Increase the deceleration time
			Decrease the system inertia
Err16	Instantaneous overload	The load is too heavy	Decrease the load or choose a larger drive.

		Output is short-circuited	Check the motor and wiring
Err17	Speed response fault	Parameter is set incorrectly	Modify or recover the parameters
		Interval time between start and stop is too short.	Set the Accel and Decel time correctly
		Wiring fault for U, V, W	Confirm the wiring
Err19	Warm reset	The power supply is instability	Check wiring or replace the drive
Err20	EEPROM error	Servo drive fault	Replace the servo drive
Err23	Current sensor adjustment fault	Servo drive fault	Replace the servo drive
Err29	Overload for motor torque	The load is too heavy	Decrease the load or choose a larger drive and motor.
		Motor code is inapplicability	choose a larger drive and motor.
		Parameter is set incorrectly	Modify or recover the parameters about motor code and torque.
Err30	Pulse Z error	Encoder fault	Replace the servo motor
		Encoder cable fault	Replace the encoder cable
		Shielding ground fault	Confirm interface and I/O circuit
Err32	U,V,W signal error for encoder	Encoder fault	Replace the servo motor
		Cable or shielding fault	Replace the cable
		Encoder signal circuit fault	Replace the drive
Err34	OT for IC	The ambient temperature is too high	Decrease the ambient temperature
Err35	UT for IC	The ambient temperature is too low	Increase the ambient temperature
Err36	Over curret	The torque of load is too high	Decrease the load or choose a larger servo drive and motor
Err37	Instantaneous overload for motor	The load is too high for motor	Decrease the load or choose a larger motor
		The motor is short-circuited	Confirm the wiring and terminals
		The motor code is incorrectly	Confirm the code parameter
Err38	Motor temperature error	The load torque is too high for motor	Decrease the load or choose a larger motor
		The motor code is set incorrectly	Confirm and modify the parameter

Chapter 8 System connection

1. Diagram for “H” series servo drive connecting with KND host controller such as K100

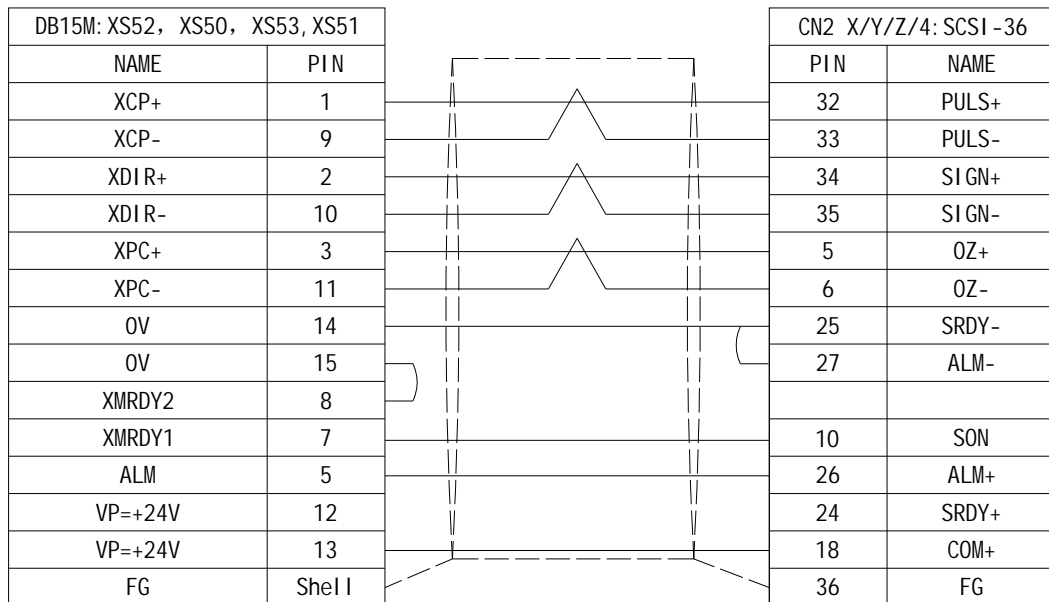

0.2mm² (shielded twisted pair cable)

2. Diagram for “H” series servo drive connecting with KND host controller such as K10M

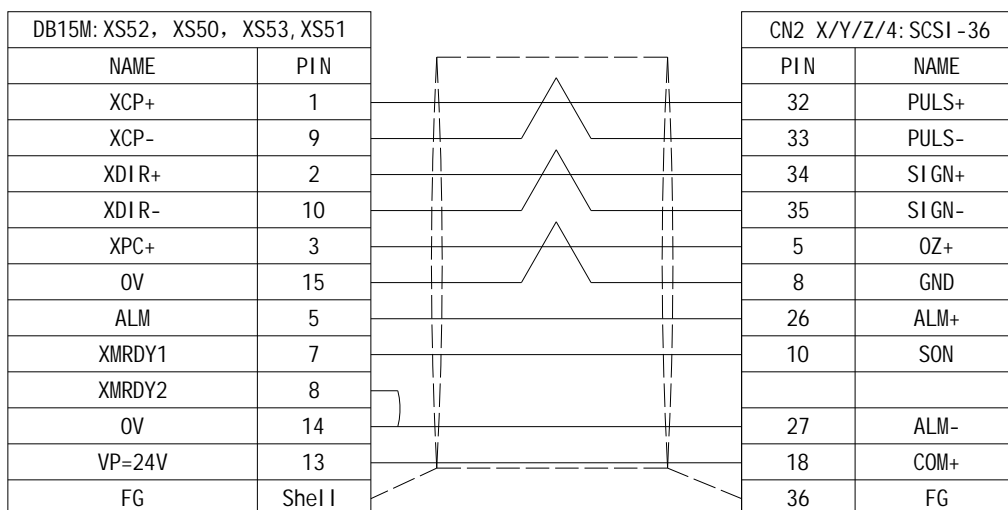

0.2mm² (shielded twisted pair cable)

3. Diagram for “H” series servo drive connecting with KND host controller such as K1

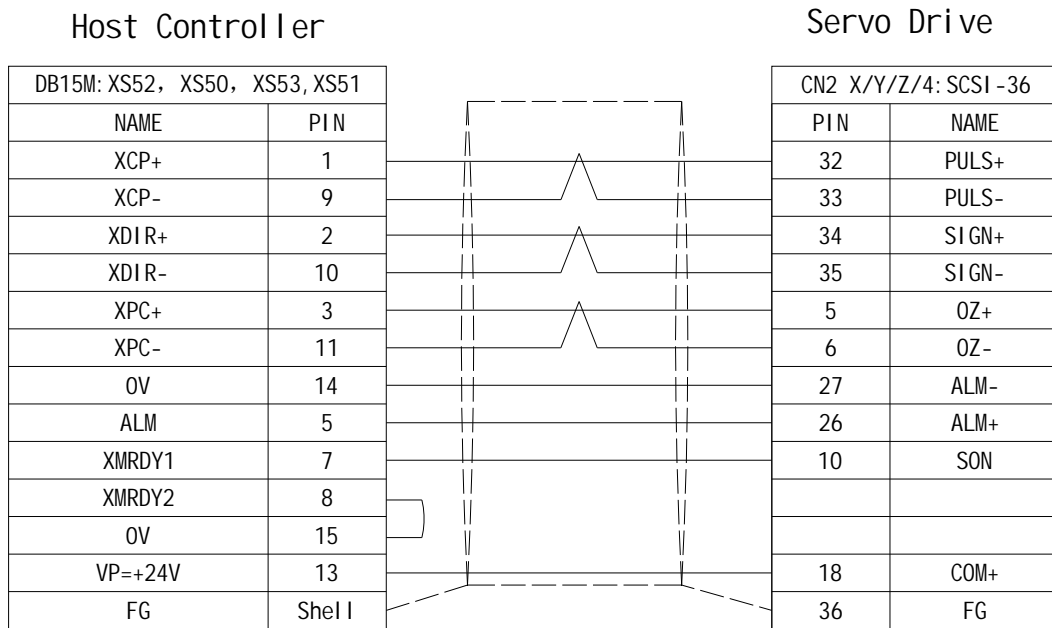

0.2mm² (shielded twisted pair cable)

4. Connecting diagram for encoder cable between Hirden drive and motor

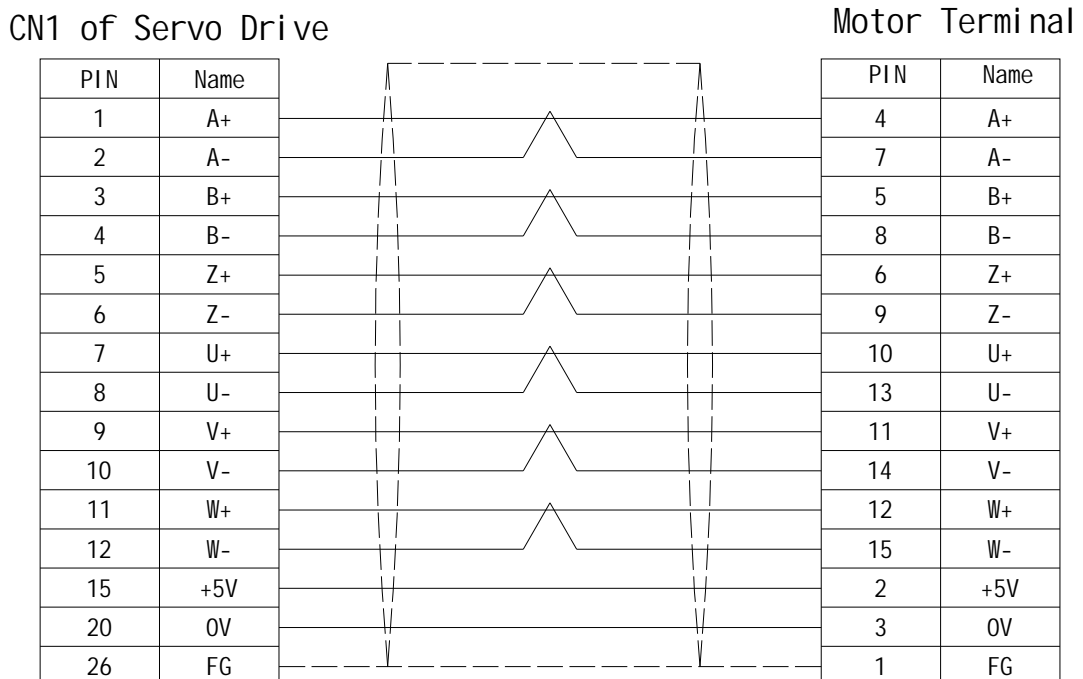

Version history

Version	Published time
1.0	2011.10
2.0	2012.11

Ningbo Hirden Industrial Control System Co.,Ltd

Zhouhan village

Jiangshan Town, Yinzhou District

Ningbo, Zhejiang 315040, China

Tel: 0574-88073813 / 83013289

Fex: (86) 0574-88099288-3813

2012.11

This page intentionally left blank.