



SOUL

FEATURES & FUNCTIONS GUIDE

www.kia.com

Consumer - Roadside Assistance
1-800-333-4KIA (4542)

See Back Cover for Vehicle Maintenance Schedule

Always check the Owner's Manual for complete operating information and safety warnings.

GETTING TO KNOW YOUR **SOUL**

Congratulations on Your New Kia Purchase!

Your new Kia vehicle has been designed, engineered and manufactured to provide you with years of comfortable and dependable driving. Kia is committed to quality, innovation, safety and — above all — your satisfaction.

Using This Guide

The information contained in this guide is a brief overview which will help you become familiar with the operation and features of your new Kia vehicle. The flipbook format facilitates information access, while the detailed illustrations ensure the instructions are easy to follow.

This **Features & Functions Guide** and the specific operational and safety information it provides is not a substitute for your Owner's Manual. In the interest of your safety and that of your family, and to help you avoid risks that may result in death or serious injury, Kia reminds you to carefully read your Owner's Manual in order to fully familiarize yourself with the important information it contains.

While the information contained in this guide is accurate at the time of printing, Kia may change vehicle specifications without notice in advance or after the fact, and assumes no liability in connection with such changes.

ESSENTIAL FEATURES

Air Conditioning / Climate Control	21
Active ECO System*	06
Audio System - Standard*	16
Audio System - UVO System*.	18
Audio System - Navigation System*	19
Aux/USB/iPod® Port & Power Outlets.	22
Bluetooth ® Wireless Technology*	14
Cruise Control*	13
Digital Clock*	20
Folding Rear Seatback.	28
ISG (Idle, Stop, Go) System*	07
Manual Gear Shift*	25
PASSENGER AIRBAG OFF Indicator	35
Tire Mobility Kit.	33
Tire Pressure Monitoring System (TPMS).	03
Windshield/Rear Wipers & Washers*	11

Driving while drowsy or distracted is dangerous and should be avoided. Drivers should remain attentive to driving and exercise caution when using vehicle systems while driving.



VIDEOS & QR CODES	02
--	----

INSTRUMENT CLUSTER

Instrument Cluster Overview	03
Tire Pressure Monitoring System (TPMS).	03
Indicators & Warning Lights	04
Trip Computer / Tripmeter*	05
LCD Display Controls and Modes*	05
Active ECO System*	06
Fuel Efficiency.	06

DRIVER'S PANEL

Instrument Panel Dimmer*	07
Electronic Stability Control (ESC).	07
ISG (Idle, Stop, Go) System*	07
Hill-Start Assist Control	07
Power Windows, Window Lock & Central Door Lock	08
Automatic Door Lock/Unlock	08
Power/Heated Outside Mirrors	08
Power Folding Mirrors*	08
Hood Release Lever and Latch	09
Fuel Door Release Lever	09
Engine Start/Stop Button*	09

STEERING WHEEL CONTROLS

Headlights & High Beams	10
Turn Signals & Fog Lights*	10
Windshield Wipers & Washers.	11
Rear Wiper & Washer*	11
Tilt/Telescopic Steering Wheel	12
Heated Steering Wheel Button*	12
FlexSteer™ Steering Wheel Mode	12
Audio Controls	13
Cruise Control*	13
Bluetooth ® Wireless Technology	14

AUDIO SYSTEM

Standard Audio System*	16
UVO System*	18
Navigation System*.	19
Advanced (Mood) Lighting Speaker*	20

CENTER PANEL

Digital Clock*	20
Aux/USB/iPod® Port*.	20
Power Outlets*	20
Automatic Climate Control*	21
Manual Climate Control*	23
Automatic Gear Shift with Sportmatic® Shifting*	24
Manual Gear Shift*	25

SEATING

Seat Warmers / Ventilated Seats*.	26
6-Way Manual Adjustable Driver's Seat.	26
Power Adjustable Driver's Seat*.	27
Front Seat Headrest Adjustment	27
Fold & Unfold Rear Seatback	28

OTHER KEY FEATURES

Smart Key*.	29
Remote Keyless Entry* (Folding Key).	30
Double-Turn Lock/Unlock All*.	30
Fuel Cap / Malfunction Indicator	30
Map/Room Lamps	31
Sunvisor	31
Panoramic Sunroof Operation*	32
Rear-Camera Display*	32
Tire Mobility Kit	33
Rear Hatch Release Button.	34
Child Safety Locks	34

SAFETY

Occupant Detection System (ODS) / PASSENGER AIRBAG OFF Indicator	35
Safety Belts	36
Safety Belt Retractor Inertial Locks	36

LEGAL DISCLAIMERS (See Back Inside Cover Page)

MAINTENANCE (See Back Cover)

Kia provides a number of video resources at your disposal to assist you with becoming familiar with the features and functions found in your Kia vehicle. You can access these resources by snapping the QR Codes with your smartphone/tablet (mobile devices) or by visiting the following website: www.KuTechVideos.com/ps13/2014. Continue reading for a more in-depth look at QR codes and for instructions on how to use them.

What are QR Codes?

A QR Code is a square, 2-dimensional barcode that can be read by mobile devices loaded with an appropriate barcode or QR Code Reader app. The app reads the barcode image and then launches/uploads the specific information the code contains, such as URLs, text, photos, videos, and so much more.

How to Use QR Codes

If you have a mobile device with a QR Code reader app, you can snap the code with your phone and you'll be provided a video with additional information pertaining to the topic. For example, in the Kia One Click Fuel Cap section, if you would like additional information, just snap the code with your mobile device to view the selected Kia Features & Functions Video.

🕒 QUICK TIPS

1. If you're having trouble scanning codes, check the following:
 - The code should be centered and focused in your mobile device's camera screen
 - Consider moving your device closer to or farther away from the code
 - The code should be well lit, without significant shadow
 - Avoid scanning from a significant angle
 - Confirm that the device's app supports 2D QR Code Scanning. Try another QR Code app; not all apps are created equal
2. After scanning, a "connecting" message appears and then nothing happens or there's a "connection error" message. These messages typically indicate that your device is having trouble connecting to the Internet

REMINDER: When accessing videos on your mobile device, standard cellular data rates will apply.

📱 QR CODE

Kia One Click Fuel Cap Video

To view a video on your mobile device, SNAP this QR Code or visit the listed website.

Refer to page 2 for more information.



www.KuTechVideos.com/ps13/2014

How to snap a QR Code

1. With your mobile device, download a QR Code Reader app. With many devices, you can do this through an app Store or Marketplace
2. Open the QR Code Reader app on your mobile device
3. The app will utilize your device's camera. Center the code in the camera viewing area:
 - With some apps, as soon as the app recognizes the code, it will launch the corresponding video
 - With other apps, you will have to snap or "take a picture of" the code. The app will then launch the corresponding video
 - For operation specifics, refer to the instructions that come with the QR Code Reader app

Instrument Cluster Overview

(Type A)

- A** Tachometer
- B** Speedometer
- C** Turn Signal Indicators
- D** Gear Shift Position
- E** Odometer
- F** Tripmeter
- G** Engine Temperature
- H** Fuel Gauge
- I** Exterior Temperature

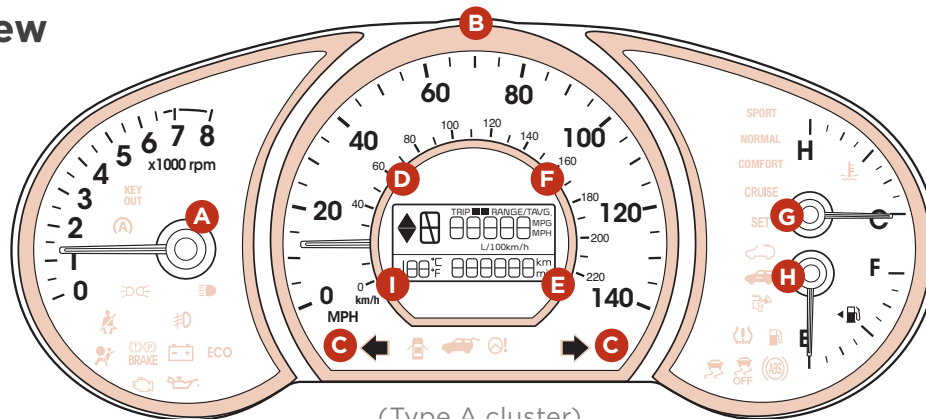

(Type A cluster)

REMINDER: Your vehicle's instrument cluster & indicator light locations may differ from those in the illustrations. See your Owner's Manual for more details.

Tire Pressure Monitoring System (TPMS)

 The indicator  functions as both Low Tire Pressure Light and TPMS Malfunction Indicator.

The TPMS indicator will illuminate if one or more tires is significantly underinflated, the vehicle has a spare tire without TPMS or the outside temperature becomes significantly colder.

Inflate tire(s) to specifications to turn off Low Tire Pressure Light  using an accurate **digital** tire pressure gauge. See front driver's door jamb for PSI specification.

The TPMS Malfunction Indicator  will illuminate after it blinks for approximately one minute when there is a problem with the TPMS. See dealer for service.

REMINDER: Consult your dealer for service if Low Tire Pressure Light remains illuminated after inflating your tire(s).

🕒 QUICK TIPS

For more information on the function of all indicator and warning lights, please refer to the Owner's Manual.

🕒 QUICK TIPS

- Even with TPMS, tire pressure should be checked manually at least once a month. Only adjust Tire Pressure on "cold tires"
- For proper maintenance and optimal fuel economy, maintain recommended tire inflation pressures and stay within the load limits and weight distribution recommended for your vehicle
- In winter or cold weather, the TPMS light may illuminate if the tire pressure was adjusted to the recommended tire inflation pressure during warm weather

📱 QR CODE

Kia Tire Pressure Monitoring System Video

To view a video on your mobile device, SNAP this QR Code or visit the listed website.

Refer to page 2 for more information.



www.KuTechVideos.com/ps13/2014

Indicators & Warning Lights

REMINDER: Your vehicle's instrument cluster & indicator light locations may differ from those in the illustrations. See your Owner's Manual for more details.

QUICK TIPS

For more information on the function of all indicator and warning lights, please refer to the Owner's Manual.

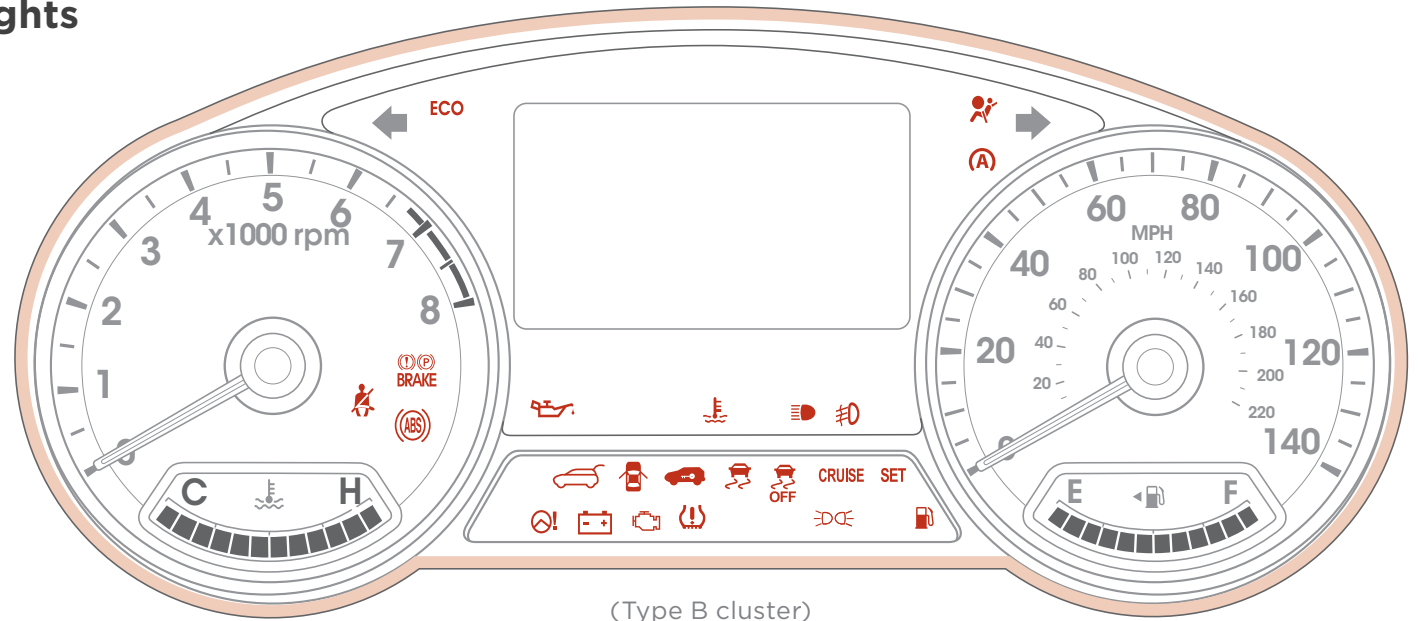

(Type B cluster)

- | | | | | | |
|--|--|--|--|--|--|
| | Seat Belt Warning Light | | Charging System Warning Light | | High Beam Indicator |
| | Electronic Brake Force Distribution (EBD) System Warning Light | | Door Ajar Warning Light | | Tail Light Indicator* |
| | Parking Brake & Brake Fluid Warning Light | | Fuel Cap / Malfunction Indicator (Check Engine Light) | | Front Fog Light Indicator* |
| | Anti-lock Braking System (ABS) Warning Light | | Immobilizer Indicator Light* | | CRUISE ON/OFF Indicator* |
| | Active ECO Indicator* | | Low Tire Pressure Light / Tire Pressure Monitoring System (TPMS) Malfunction Indicator | | CRUISE SET Indicator* |
| | Engine Oil Pressure Warning Light | | Engine Coolant Temperature Warning Light | | Low Fuel Level Warning Light |
| | Electronic Power Steering Warning Light | | Electronic Stability Control (ESC) Indicator | | Airbag Warning Light |
| | Tailgate Open Warning Light | | Electronic Stability Control (ESC) OFF Indicator* | | Auto Stop (ISG System) Indicator |
| | | | | | Fuel Cap Open Warning Indicator (In cluster type B, displays in LCD) |

Trip Computer / Tripmeter*

The Trip Computer is a driver information system that displays information related to driving — such as Odometer, Tripmeter, Range, Average Fuel Consumption and Driving Time — on the display when the ignition switch is in the ON position.

To cycle through the LCD Display modes, press the Mode/Select button **A**.

When in the Trip Computer mode , press the Move/Reset button **B** to cycle through the screens. When displaying Trip A or Trip B screens, press and hold the Move/Reset button **B** to reset the Tripmeter to zero.

REMINDER: Appearance of Tripmeter display may differ as equipped.

REMINDER: All stored driving information (except Odometer and Range) is reset if the battery is disconnected.

(Type B cluster)

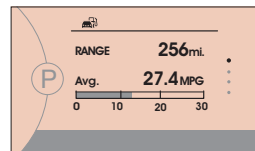

Trip Computer First Screen:

- Range
- Average MPG
- Instant MPG

- Trip A
- Average MPH
- Elapsed Time (E/T)

- Trip B
- Average MPH
- Elapsed Time (E/T)

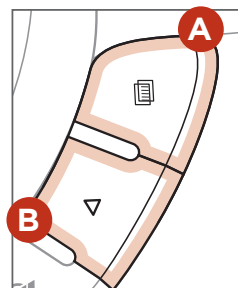

(Buttons located on Steering Wheel)

LCD Display Controls and Modes*

(Type B cluster only)

To cycle through the LCD modes, press the Mode/Select button **A**

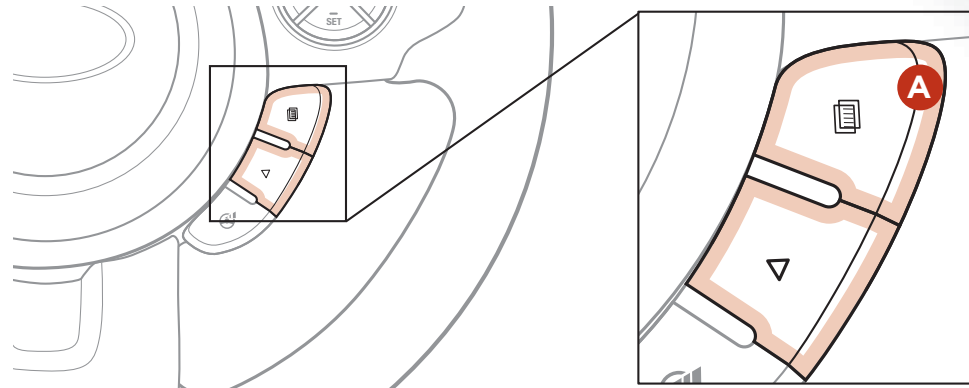

(LCD Display Control buttons located on Steering Wheel)



Trip Computer Mode: Displays driving information for tripmeter, fuel economy, etc.



Turn-by-Turn Mode*: Displays the state of the Navigation system



A/V Mode*: Displays the state of the A/V System



Master Warning / Service Modes: Informs on upcoming service intervals, and warning messages related to TPMS and others



User Settings Mode: Change settings of the doors, lamps and other features

Active ECO System*

Active ECO helps improve fuel efficiency by controlling several vehicle components. When activated, it optimizes drivetrain operations such as engine power and transmission to maximize fuel economy.

To turn ON, press the Active ECO button **B**. The button light will turn on and the green ECO indicator light **A** in the instrument cluster will illuminate (indicating that you are getting optimal fuel efficiency). The Active ECO System will remain on even when the engine is turned off and restarted.

To turn Active ECO OFF, press the button **B** again.

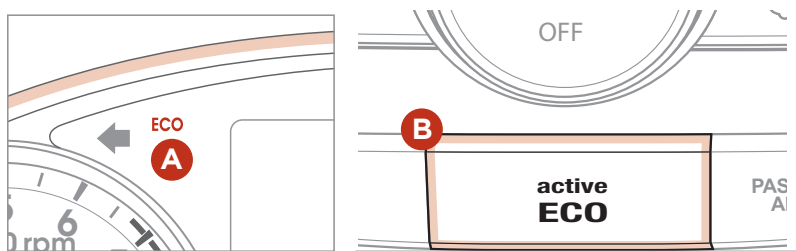

(Type B cluster)

For more information on the ACTIVE ECO Indicator, refer to your Owner's Manual or contact your local dealership.

🔔 QUICK TIPS

To help improve your fuel efficiency:

- Drive at a moderate speed, accelerating smoothly and at a moderate rate
- Keep tires inflated to the recommended pressure
- Be sure the wheels are properly aligned

Fuel Efficiency

There are several factors that contribute to your vehicle's fuel efficiency including maintenance of your vehicle, driving style, environmental conditions, vehicle weight and vehicle aerodynamics. Below are tips on how to help improve fuel efficiency.

- Keep your vehicle in good condition with regular maintenance
- Don't let the engine idle longer than necessary
- Drive at a moderate speed, accelerating smoothly and at a moderate rate
- Keep tires inflated to the recommended pressure
- Travel lightly, without carrying unnecessary weight in your vehicles
- Avoid placing large or heavy items on roof racks
- Avoid hilly, winding or poorly maintained roads

REMINDER: Driving range can vary depending on your vehicle's fuel tank size, e.g., 12-gal. vs. 24-gal., even though the MPG may be the same

For more information on Fuel Economy, you can snap the QR code above to view a video or refer to the brochure, "Getting More Out Of Every Gallon, Fuel-Saving Tips To Drive By" available at your local dealership.

📱 QR CODE

To view a video on your mobile device, SNAP this QR Code or visit the listed website.

Refer to page 2 for more information.

Active ECO Indicator Video



www.KuTechVideos.com/ps13/2014

Fuel Economy Video



www.KuTechVideos.com/ps13/2014

Instrument Panel Dimmer*

With parking lights / headlights ON, press button **A** + or - to adjust display brightness of the instrument panel illumination.

REMINDER: Door Mood Lamp is a fixed brightness and cannot be adjusted (not to be confused with Advanced Mood Lighting Speaker).

REMINDER: The Instrument Panel Dimmer does not adjust brightness on the Navigation System screen, use Navigation setup.

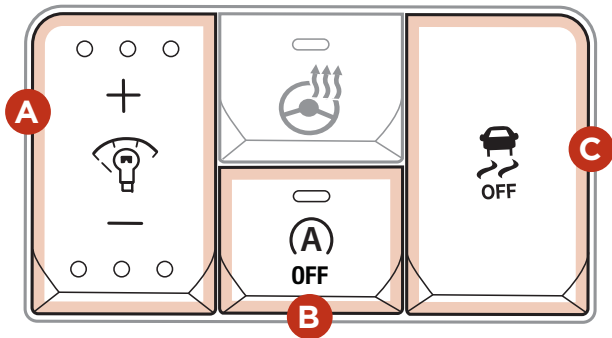

Electronic Stability Control (ESC)

The ESC system is designed to help stabilize the vehicle during cornering maneuvers. It is a good idea to keep the ESC turned ON for daily driving whenever possible.

Press ESC button **C** to turn ESC OFF/ON.

REMINDER: ESC is turned ON at vehicle start-up.

REMINDER: The ESC Indicator Light in the instrument cluster will be lit momentarily whenever the ESC is active.

ISG (Idle, Stop, Go) System*

The ISG system helps reduce fuel consumption by automatically shutting down the engine when the vehicle is at a standstill.

When the vehicle is at a standstill, the engine will stop and the green AUTO STOP indicator **A** on the instrument cluster will illuminate and the message Auto Stop will appear in the LCD display*.

To restart engine from Idle Stop Mode, release the brake pedal or move the shift lever to the R (Reverse) position or Sports Mode while depressing the brake pedal. The engine will start and the green AUTO STOP indicator **A** on the instrument cluster will turn off.

To deactivate the ISG System, press the ISG OFF button **B**. If you press again, the system will be activated.

REMINDER: ISG System is ON at vehicle start up.

For more information on the ISG System, please refer to your Owner's Manual or contact your local dealership.

Hill-Start Assist Control (HAC)

HAC helps prevent the vehicle from rolling backward when accelerating from a stop while on a steep incline. The HAC automatically activates whether the ESC is OFF or ON but does NOT activate when the ESC has malfunctioned.

REMINDER: The HAC does not operate when the gear shift is in the P (Park) or the N (Neutral) position.

QR CODE

Kia ISG (Idle, Stop, Go) System Video

To view a video on your mobile device, SNAP this QR Code or visit the listed website.

Refer to page 2 for more information.



www.KuTechVideos.com/ps13/2014

QUICK TIPS

- HAC provides a 2-second delay before the vehicle may start rolling backwards.
- When HAC is active (e.g., accelerating from a stop on an incline), you may notice that the brakes will momentarily remain engaged after you depress the accelerator.

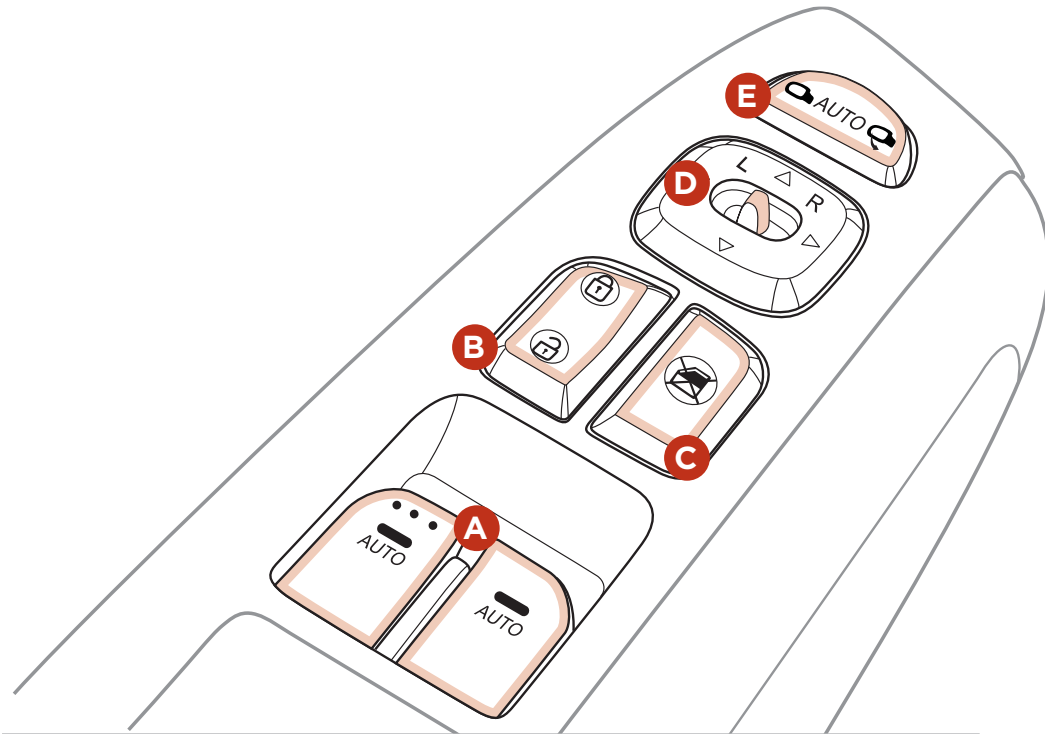
Power Windows, Window Lock & Central Door Lock

A Pull/Press to operate Driver's and Passenger's window Auto Up/Down

B Press to Unlock/Lock All Doors

C Press to disable Rear Passenger Windows

REMINDER: When button **C** is pressed, window controls for the Rear Passenger Windows are disabled.

Ⓢ QUICK TIPS

Auto Door Lock/Unlock* will engage when gear shift is moved in to or out of the P (Park) position.

Automatic Door Lock/Unlock

When the gear shift is moved in to or out of P (Park), all doors will Lock/Unlock.

Power/Heated Outside Mirrors

Mirror heaters controlled with Rear Defroster.

Power Folding Mirrors*

Toggle switch **D** left or right to select mirror. Then press arrows to adjust Power Folding Outside Mirror position.

Toggle button **E** left/right to unfold/fold the outside rearview mirrors.

Toggle button **E** to center to automatically fold/unfold mirrors when:

- The Smart Key Lock/Unlock buttons are pressed
- The door outside handle button is pressed

REMINDER: To automatically fold mirrors when exiting vehicle, press the LOCK button on the Smart Key.

REMINDER: To lock position of mirrors, toggle switch to the neutral (center) position.

Ⓢ QUICK TIPS

The mirrors will automatically unfold when the Smart Key* is within close proximity to the vehicle.

Hood Release Lever and Latch

Opening the Hood:

1. Located on the bottom left of the driver's panel, pull the Hood Release Lever **A** to unlatch the Hood

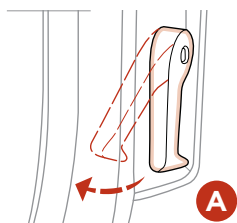

2. In the front of the vehicle, lift the Hood slightly, push the secondary Latch **B** up inside of the Hood's center and lift the Hood

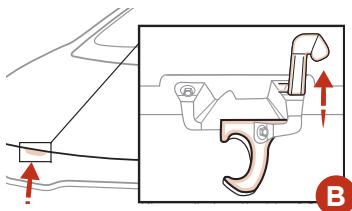

Closing the Hood:

Lower the Hood pressing by pressing the front center of the Hood. Then, press down to securely lock in place.

REMINDER: While lowering and closing, keep hands away from under the Hood.

Fuel Door Release Lever

Lift the **C** lever upwards to release the fuel door.

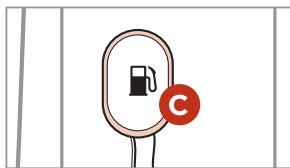

(Lever located on the driver's floor near door sill)

Engine Start/Stop Button*

To start the engine:

1. Depress the brake pedal
2. Press the ENGINE START/STOP button while in Park (or while in Neutral for Manual Gear Shift)

To use the ENGINE START/STOP button, you must have the Smart Key* fob on your person. To turn the vehicle OFF, press the ENGINE START/STOP button.

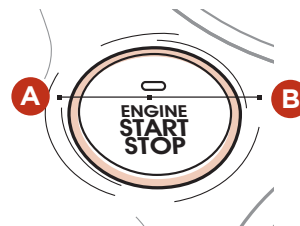
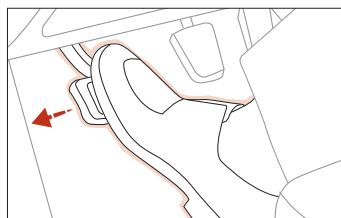

REMINDER:

- In an emergency situation while the vehicle is in motion, you are able to turn the engine off and to the ACC position by pressing the ENGINE START/STOP button for more than 2 seconds or 3 times within 3 seconds.
- If Smart Key fob battery is dead, hold the fob up against the Engine Start/Stop button

⌚ QUICK TIPS

To use electrical accessories:

ACC position

- When in the OFF position (no light) and without depressing the brake pedal, press the ENGINE START/STOP button once (Amber light **A**)

On position

- When already in the ACC position (Amber light **A**) and without depressing the brake pedal, press the ENGINE START/STOP button again (Reddish-orange light **B**)
- When in the OFF position (no light) and without depressing the brake pedal, press the ENGINE START/STOP button twice (Reddish-orange light **B**)

Keeping the vehicle in ACC or the ON position without driving may discharge the vehicle's battery.

📱 QR CODE

Kia Engine Start/Stop Button & Smart Key Video

To view a video on your mobile device, SNAP this QR Code or visit the listed website.

Refer to page 2 for more information.



www.KuTechVideos.com/ps13/2014

Headlights & High Beams

AUTO Light* function — When the light switch is in the AUTO light position, the tail lights and headlights will turn ON/OFF automatically depending on the amount of light outside the vehicle.

Push lever to turn High Beams ON. Pull lever to flash Headlights/High Beams.

Rotate lever to change the Headlight function:

- AUTO*** Automatic Headlights position
-  Headlight position
-  Parking light position
- OFF** OFF position

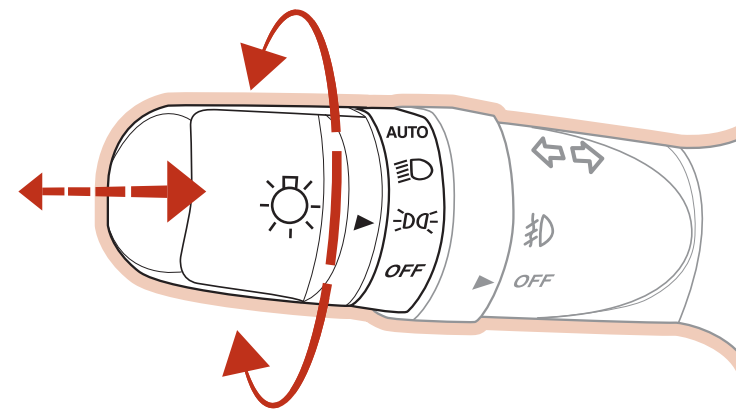

Turn Signals & Fog Lights*

One-Touch Lane Change Signal is activated by moving the Turn Signal Lever slightly for less than 1 second and then releasing. The lane change signal will blink 3 times.

To change how many times the Lane Change Signal blinks (3/5/7), go to User Settings Mode in the LCD Display (Type B cluster).

For more information on the User Settings Mode, please refer to your Owner's Manual.

REMINDER: Headlights must be ON for Fog Light operation.

Move lever Up/Down for Right/Left Turn Signal.

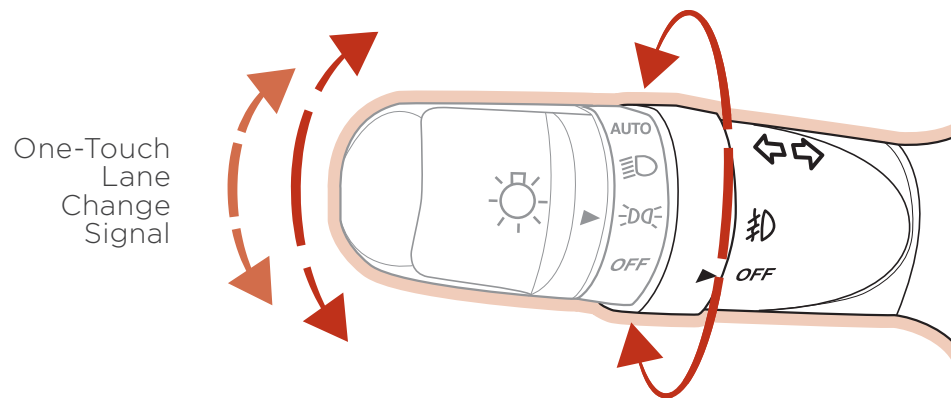

Rotate lever ring to turn Fog Lights ON/OFF.

Windshield Wipers & Washers

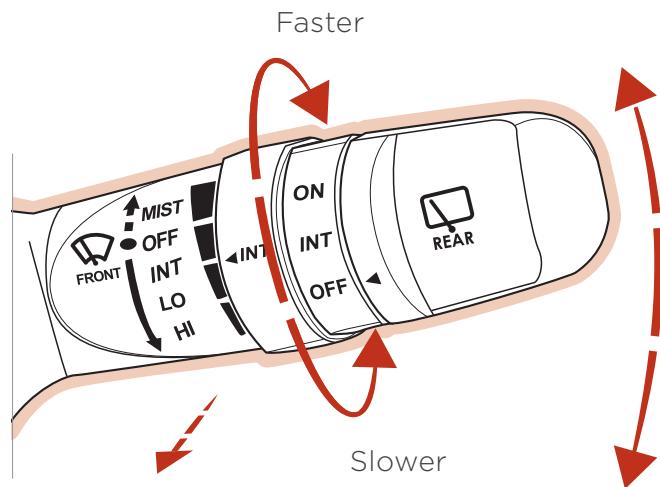

Pull to spray and wipe.

Rear Wiper & Washer*

Push to spray and wipe.

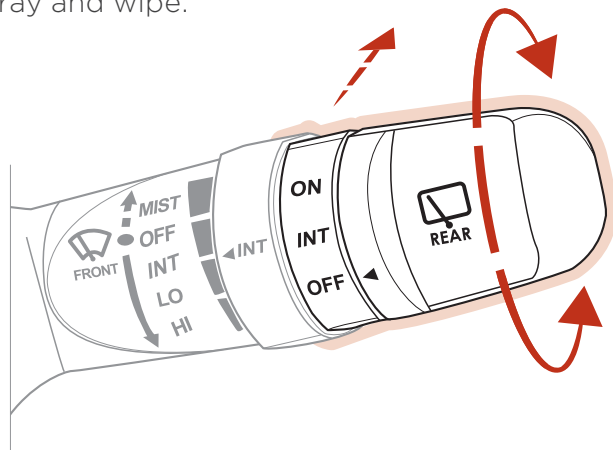

Rotate lever to adjust Intermittent Wipe Speed.

MIST: Single wipe

OFF: Wiper off

INT: Intermittent wipe

LO: Slow wipe

HI: Fast wipe

Rotate Up/Down to change Wiper modes.

ON: Normal wipe

INT: Intermittent wipe

OFF: Wiper off

QR CODE

Soul Windshield Wipers & Washer Video

To view a video on your mobile device, SNAP this QR Code or visit the listed website.

Refer to page 2 for more information.



www.KuTechVideos.com/ps13/2014

Tilt/Telescopic Steering Wheel

To adjust the Steering Wheel, push down the lock-release lever **B** and adjust to desired angle **C** and distance **D**.

When finished, pull up the lock-release lever **B** to lock Steering Wheel in place.

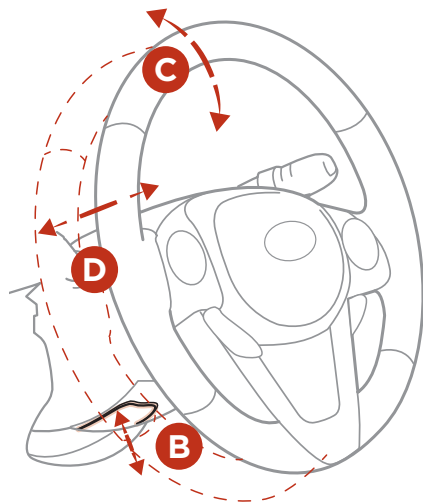

Heated Steering Wheel Button*

Press button **A** to turn ON/OFF steering wheel heater, while the Engine Start/Stop Button is in the ON position. Steering wheel heater will turn off automatically in 30 minutes, or when button is pressed again to deactivate.

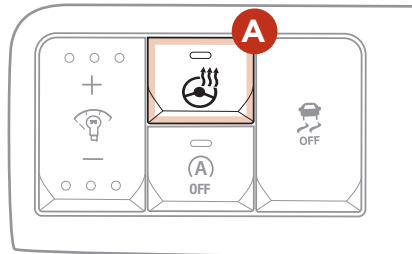

🕒 QUICK TIPS

If ignition is turned OFF, then ON again, within 30 minutes of steering wheel heater being turned on, system will automatically be set ON again.

FlexSteer™ Steering Wheel Mode

Select the desired steering mode by toggling through the steering modes.

- Press FlexSteer™ Steering Wheel Mode button **E** to display the steering mode on the LCD display*.
- Then press the button **E** again within 4 seconds to switch modes.

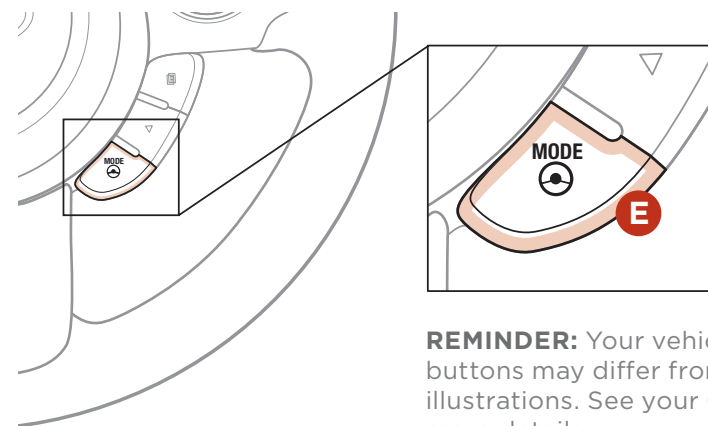
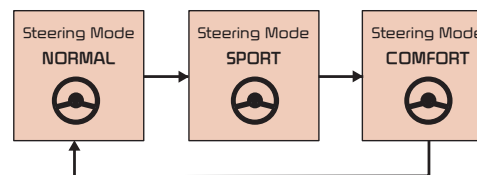

REMINDER: Your vehicle's steering wheel buttons may differ from those in the illustrations. See your Owner's Manual for more details.

📱 QR CODE

FlexSteer™ Steering Wheel Mode Video

To view a video on your mobile device, SNAP this QR Code or visit the listed website. Refer to page 2 for more information.



www.KuTechVideos.com/ps13/2014

Audio Controls

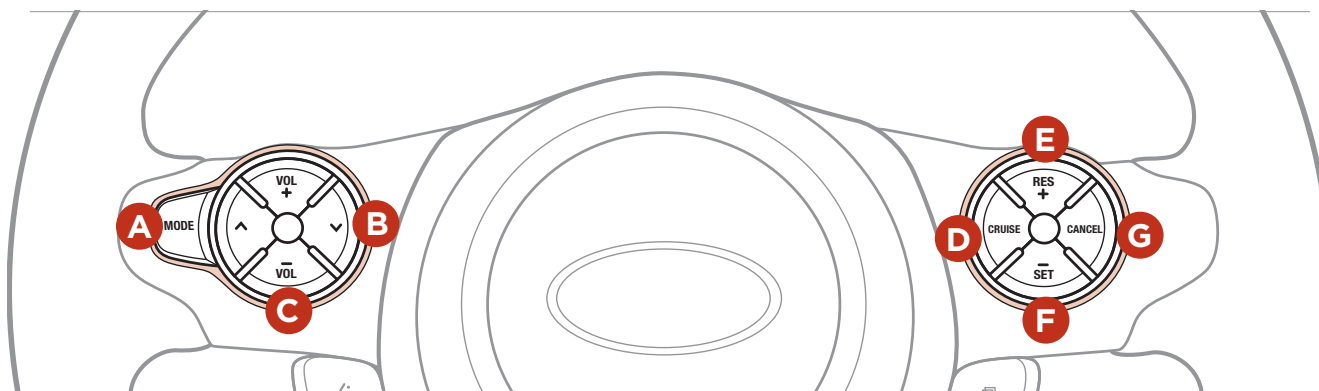

- A Audio Mode:** Press to cycle through FM/AM/SiriusXM® Media (USB, iPod®, Aux, BT Audio, My Music)
- B Seek/Preset button**
Radio Mode: Press to advance through Preset Stations. Press and hold to AUTO SEEK
USB/iPod® Mode: Press to move track up/down. Press & hold to FF/REW
- C Volume button:** Press up/down to raise/lower volume

REMINDER: Your vehicle's steering wheel buttons may differ from those in the illustrations. See your Owner's Manual for more details.

REMINDER: Driving while distracted is dangerous and should be avoided. Drivers should remain attentive to driving and always exercise caution when using the steering-wheel-mounted controls while driving.

Cruise Control*

- D Cruise Control ON/OFF button:** Press to turn the Cruise Control ON/OFF
- E Resume Cruising Speed button:** Resume or increase Cruising Speed
- F Set Cruising Speed button:** Press to set or decrease Cruising Speed
- G Cruise Control Cancel button:** To cancel Cruise Control setting, do one of the following:
 - Press the brake pedal
 - Press the CANCEL button **G**

Ⓢ QUICK TIPS

Pressing the Audio Mode button for more than 1 second will turn Audio Mode ON/OFF.

For further audio system operations, refer to pages 14-19.

Ⓢ QUICK TIPS

- Cruise Control is designed to function above 25 mph.
- The Cruise Control system will not activate until the brake pedal has been depressed at least once after ignition ON or engine starting

Bluetooth® Wireless Technology

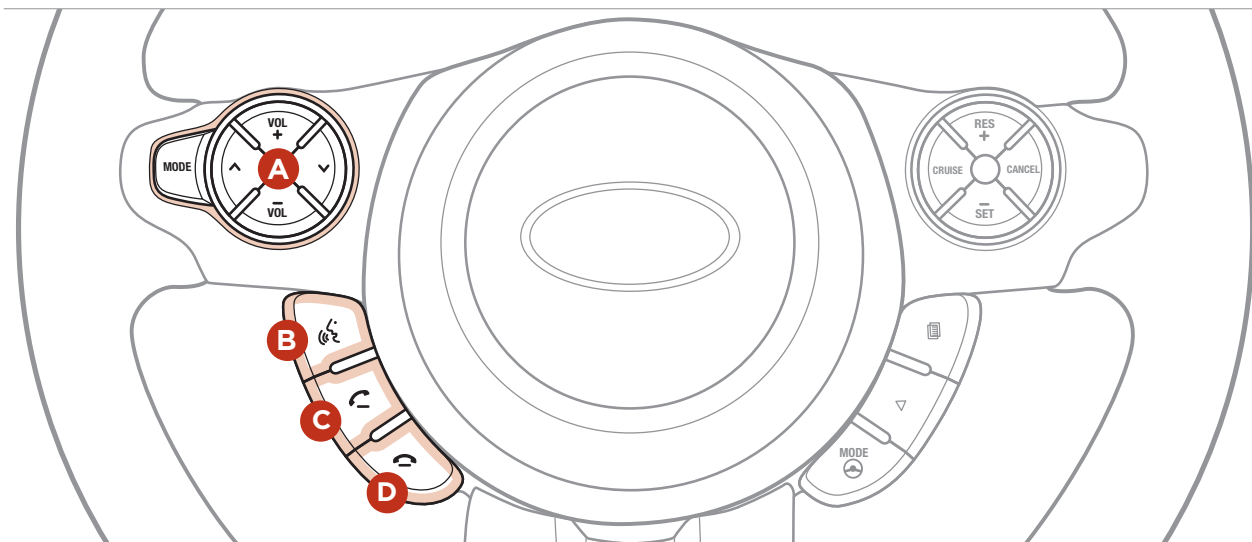

A Volume button: Press up/down to raise/lower speaker volume

B Talk button: Press to activate voice recognition / bring up menus / place calls with minimal voice command prompts from the system

ⓘ QUICK TIPS

When using the voice command feature, wait for the system BEEP before speaking the command.

C Receive/Place Call button: Press to receive/transfer calls. Press to place a call using vocal command prompts from the system, or to answer an incoming call

D End Call button: Press to end a call or cancel a function

REMINDER: Microphone is located in the overhead console.

ⓘ QUICK TIPS

- Phonebook transfer upload time varies by phone model and with number of phonebook entries
- Because of differences in phone quality, service providers and **Bluetooth®** Wireless Technology chip programming, functionality may differ from one phone to another

For more information, refer to the *Digital Navigation Systems User's Guide* or the *UVO System User's Manual*.

For **Bluetooth®** Wireless Technology FAQs, go to www.kia.com, Owners section.

Refer to your Owner's Manual for more specific **Bluetooth®** Wireless Technology phone pairing and operation instructions.

REMINDER: Your vehicle's steering wheel buttons may differ from those in the illustrations. See your Owner's Manual for more details.

REMINDER: Driving while distracted is dangerous and should be avoided. Drivers should remain attentive to driving and always exercise caution when using the steering-wheel-mounted controls while driving.

Bluetooth® Wireless Technology

Pairing a Phone

For instructions on how to pair a phone, refer to the audio system's user's guide or your vehicle's Quick Start Guide.

Ⓢ QUICK TIPS

During the pairing process, be sure to accept the connection requests on the phone for phonebook download and to allow acceptance of all future **Bluetooth**® connection requests.

How to Place a Call

When using the voice command feature, wait for the system BEEP before speaking the command.

There are two options for placing a call:

Standard Audio System

- **Option 1:** Press the Receive/Place Call button **C** (system will prompt you through call process)
- **Option 2:** Press the Talk button **B** (system will BEEP to indicate it is ready for call placement). Then say the command "Call {name}" or "Dial {number}"

UVO System

- **Option 1:** Press the Receive/Place Call button **C** (displays the phone screen with number keypad)
- **Option 2:** Press the Talk button **B**. Then say the command "Call {name}" or "Dial {number}"

Navigation System

- **Option 1:** Press the Receive/Place Call button **C** (displays the phone screen with number keypad)
- **Option 2:** Press the Talk button **B**. Then say the command "Call {name}" or "Dial {number}"

Voice Recognition and Phone Contact Tips

The Kia Voice Recognition System may have difficulty understanding some accents or uncommon names. When using Voice Recognition to place a call, speak in a moderate tone, with clear pronunciation.

Help your Bluetooth® Wireless Technology Voice Recognition performance by making a few simple changes to your phone contacts:

- Use full names vs. short or single syllable names ("John Smith" vs. "Dad", "Smith Residence" vs. "Home")
- Avoid using special characters or hyphens (@, &, #, /, -, *, +, etc.)
- Avoid using acronyms ("In Case Emergency" vs. "ICE")
- Spell words completely, no abbreviations ("Doctor Goodman" vs. "Dr. Goodman")

Ⓢ QUICK TIPS

Contacts Sync Tips

- If Contact Sync is set to ON, contacts store in your phone will download each time your phone is connected. There may be a delay before the system is available to place a call
- If Contact Sync is set to OFF, your phone contacts will download only at the initial pairing. This allows you to make calls without waiting for your phone contact list to download

📱 QR CODE

Voice Recognition Tips Video

To view a video on your mobile device, SNAP this QR code or visit the listed website.

Refer to page 2 for more information.



www.KuTechVideos.com/ps13/2014

**Standard Audio System Overview/Operation —
AM/FM/SiriusXM®/Media (USB, iPod®, Aux, BT Audio, My Music)***

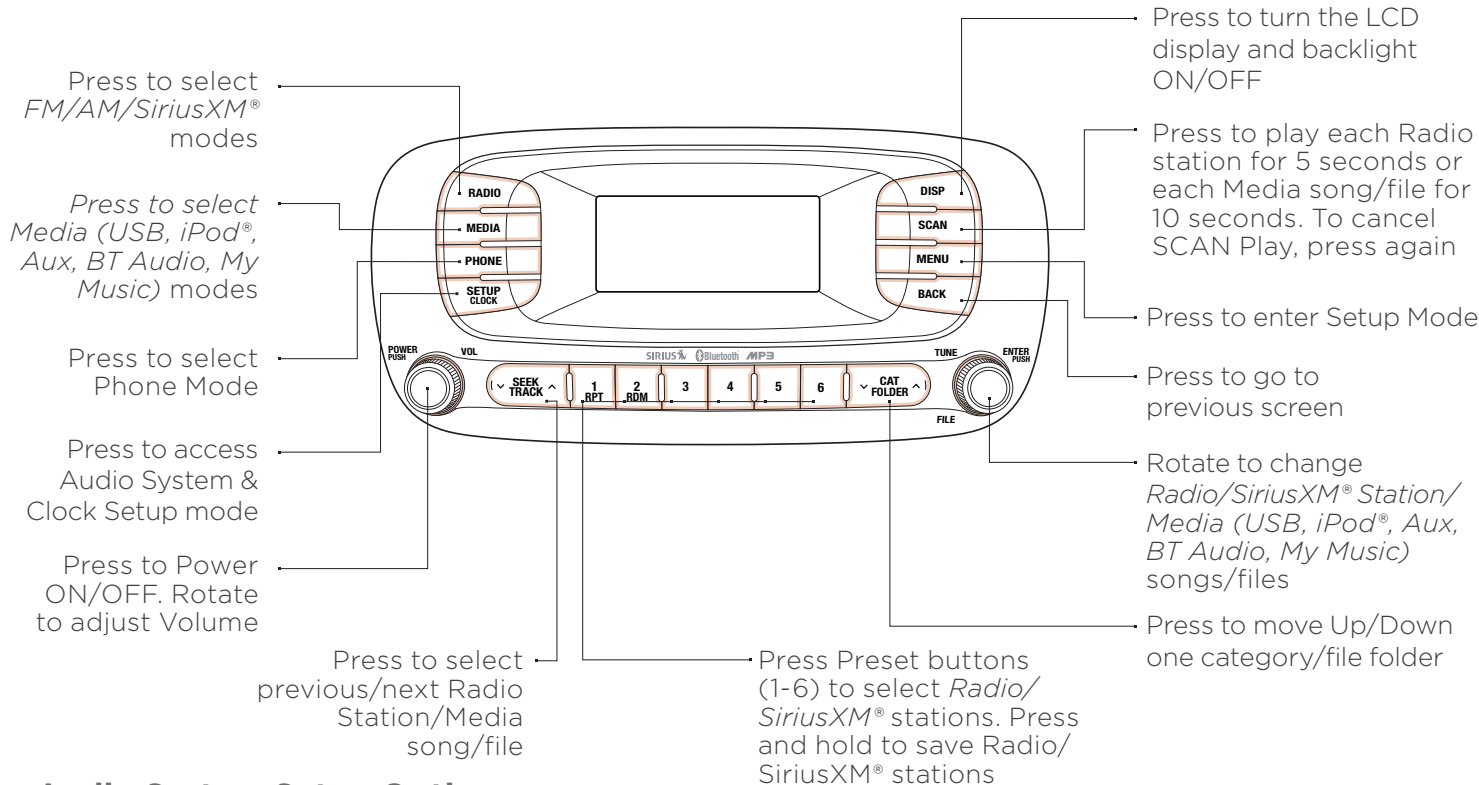

Audio System Setup Options

Press the SETUP button, then use the TUNE knob to cycle through the available settings for each equipped audio option. Press the TUNE Knob to adjust the audio option selected. Audio options may include the following:

Display Setup

- Mode Popup
- Text Scroll
- Media Display

Sound Setup

- Sound Settings
- Speed Dependent Volume
- Voice Recognition Volume

Clock Setup

- Clock Settings
- Calendar Settings
- Time Format
- Clock Display ON/OFF

System Setup

- Memory Information
- Prompt Feedback
- Language

REMINDER: SiriusXM® service not available in AK or HI.

For further audio system operations, refer to pages 13-19.

QR CODE

Standard Audio System Videos

To view a video on your mobile device, SNAP this QR Code or visit the listed website.

Refer to page 2 for more information.



http://kutechvideos.com/audio/base_system

REMINDER: Your vehicle's audio system may differ from that in the illustration. See your Owner's Manual for more details.

Standard Audio System Operation — Media (USB, iPod®, Aux, BT Audio, My Music)*

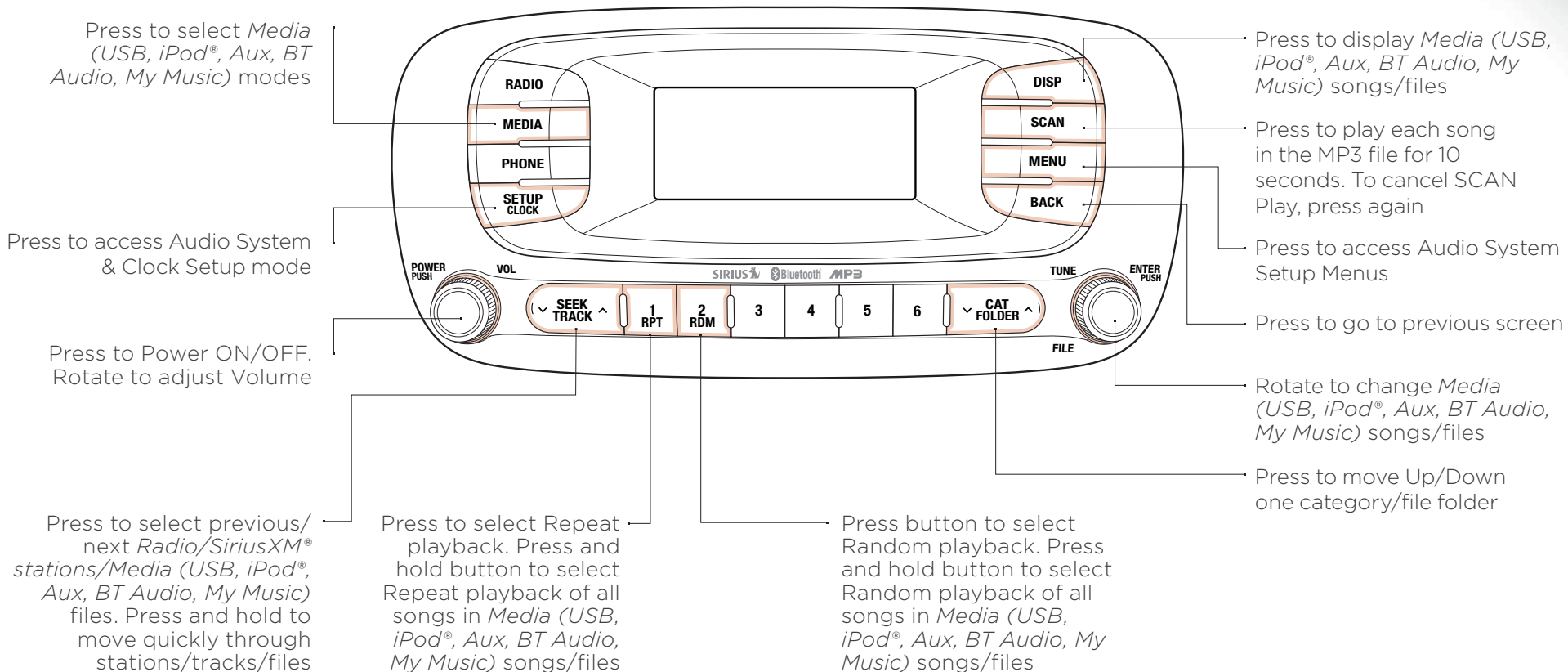

REMINDER: Your vehicle's audio system may differ from that in the illustration. See your Owner's Manual for more details.

REMINDER: SiriusXM® service not available in AK or HI.

For further audio system operations, refer to pages 13-19.

UVO System*

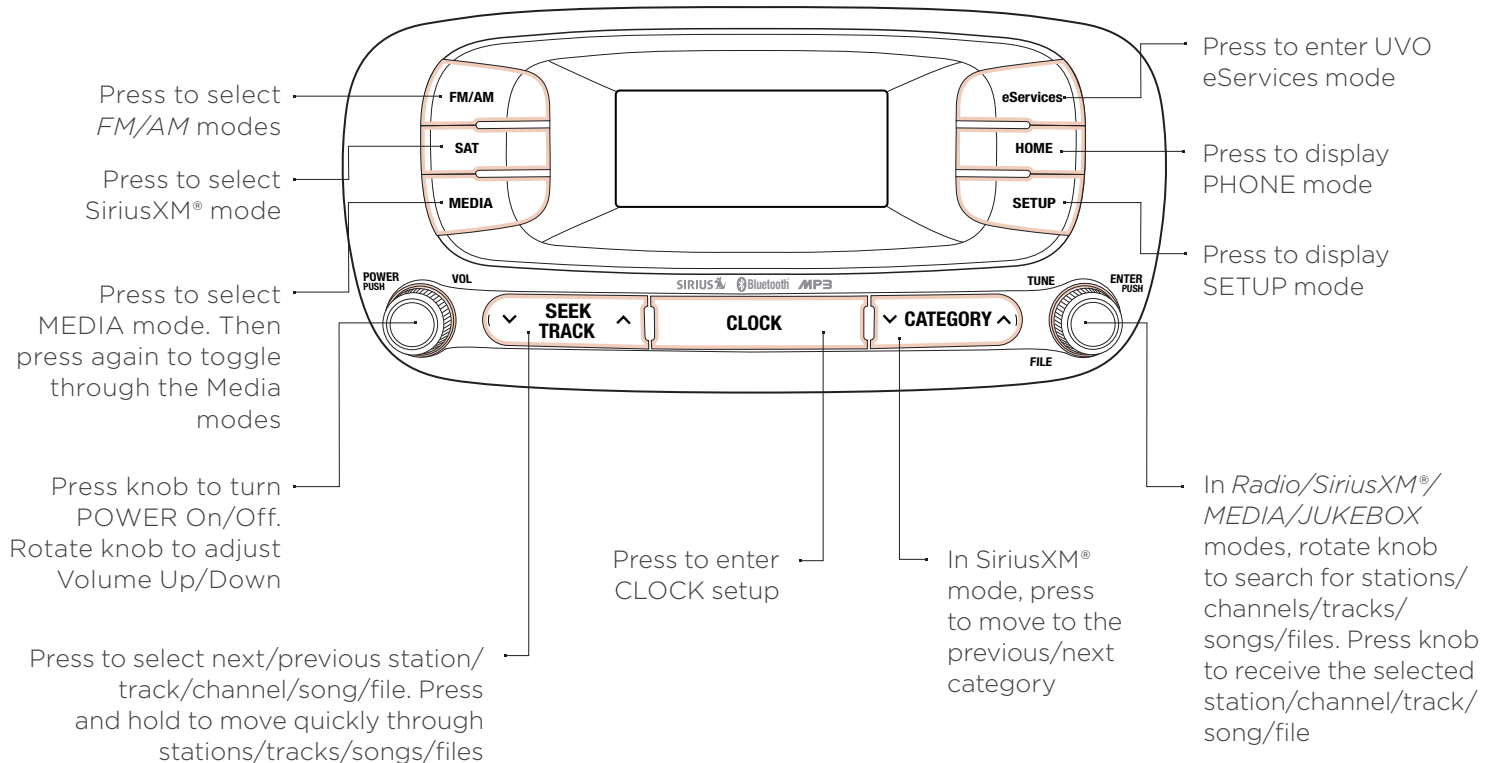

QR CODE

UVO System Videos

To view a video on your mobile device, SNAP this QR Code or visit the listed website. Refer to page 2 for more information.



http://kutechvideos.com/audio/UVO_eServices

🕒 QUICK TIPS

- When using the voice command feature, wait for the system BEEP before speaking the command
- Prolonged use of the UVO system in ACC mode may drain the vehicle's battery.

REMINDER: SiriusXM® service not available in AK or HI.

For further navigation system operation, refer to the UVO System User's Manual.

For further audio system operations, refer to pages 13-19.

🕒 QUICK TIPS

- Only MP3 or WMA files may be played or copied to Jukebox—commercial CDs or CDs with a CDDA audio format (compact disc digital audio) cannot be copied to Jukebox
- At any time you can interrupt UVO System Command Feedback by pressing the TALK button

REMINDER: Your vehicle's audio system may differ from that in the illustration. See your Owner's Manual for more details.

Navigation System with AM/FM/SiriusXM®/CD/Aux/USB/iPod®/ BT Audio/My Music*

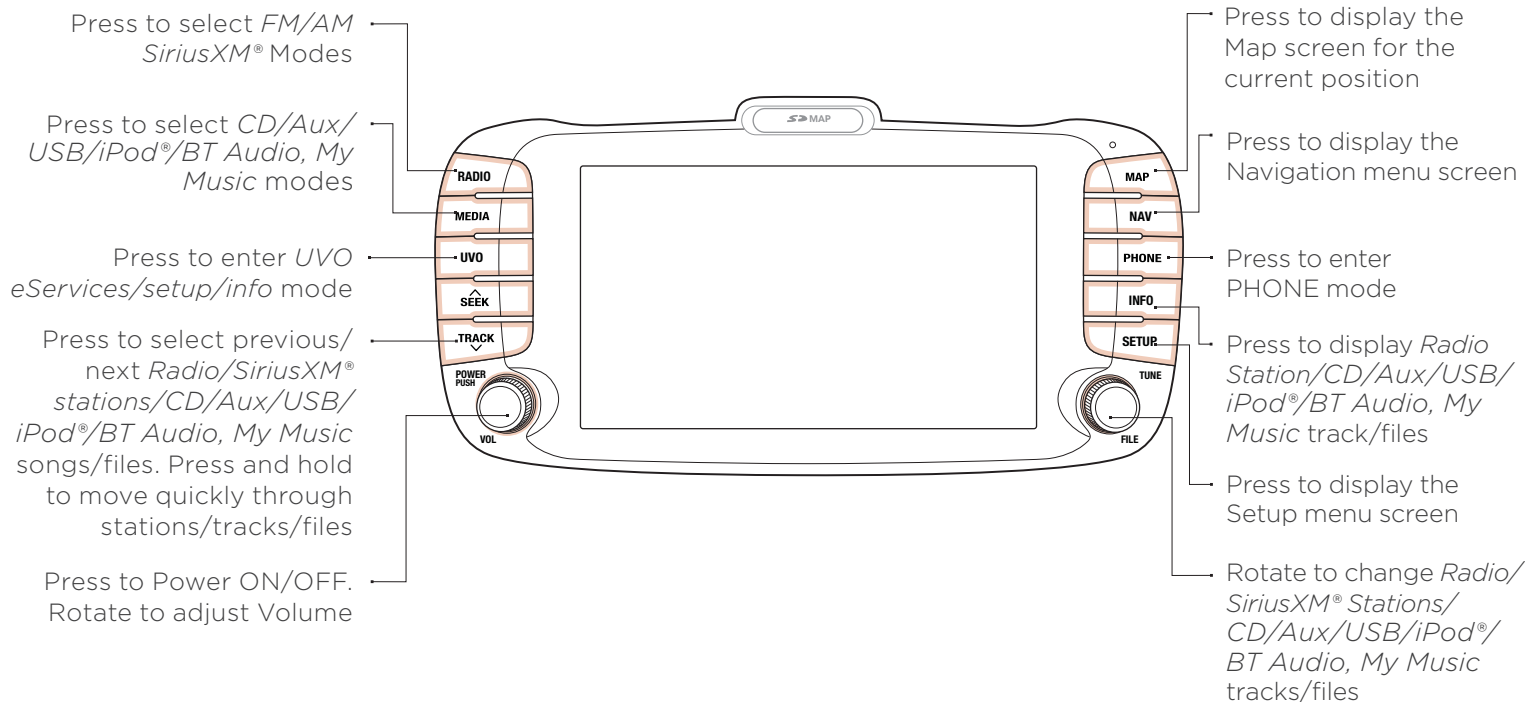

QR CODE

Navigation Audio System Videos

To view a video on your mobile device, SNAP this QR code or visit the listed website. Refer to page 2 for more information.



<http://www.kutechvideos.com/audio/avn4>

QUICK TIPS

When using the voice command feature, wait for the system BEEP before speaking the command.

REMINDER: SiriusXM® service not available in AK or HI.

For further navigation system operation, refer to the Digital Navigation System User's Manual.

For further audio system operations, refer to pages 13-19.

QUICK TIPS

Prolonged use of the Navigation system in ACC mode may drain the vehicle's battery. A warning screen may appear periodically to remind users that the Navigation System should be operated with the engine running to prevent battery discharge.

REMINDER: Your vehicle's audio system may differ from that in the illustration. See your Owner's Manual for more details.

Advanced (Mood) Lighting Speaker*

The Advanced (Mood) Lighting Speaker that lights around the front speaker is controlled by turning the knob and pressing the buttons (located to the left of the steering wheel).

MOOD : Light intensity and color changes automatically at regular intervals.

MUSIC: Speaker light pulses and changes intensity according to the audio sound (audio must be on for this feature to work).

OFF: Speaker light turns OFF.

+/- : When light is ON, press illumination buttons to adjust light intensity.

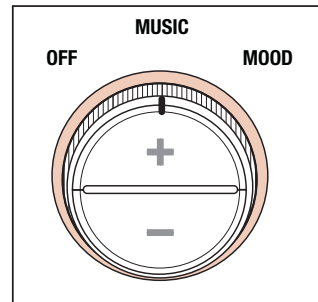

🕒 QUICK TIPS

- Door must be closed for this feature to work.
- Prolonged use of lighting speaker in ACC mode may drain the vehicle's battery.

Digital Clock*

Standard Audio System Clock Setup:

1. Press the SETUP button
2. Rotate knob to select Clock mode, then press to enter
3. Rotate knob to adjust Hour, then press to enter
4. Rotate knob to adjust Minute, then press to enter

Aux/USB/iPod® Port* & Power Outlets*

🕒 QUICK TIPS

The power outlets are inactive when ignition is in the OFF position

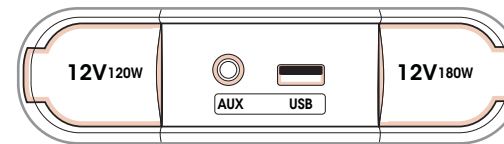

REMINDER: For the Tire Mobility Kit, only use the **12V/15A/180W** Power Outlet, located on the right side of the outlet/aux. port area.

📱 QR CODE

Kia USB Port Video

To view a video on your mobile device, SNAP this QR code or visit the listed website.

Refer to page 2 for more information.



www.KuTechVideos.com/ps13/2014



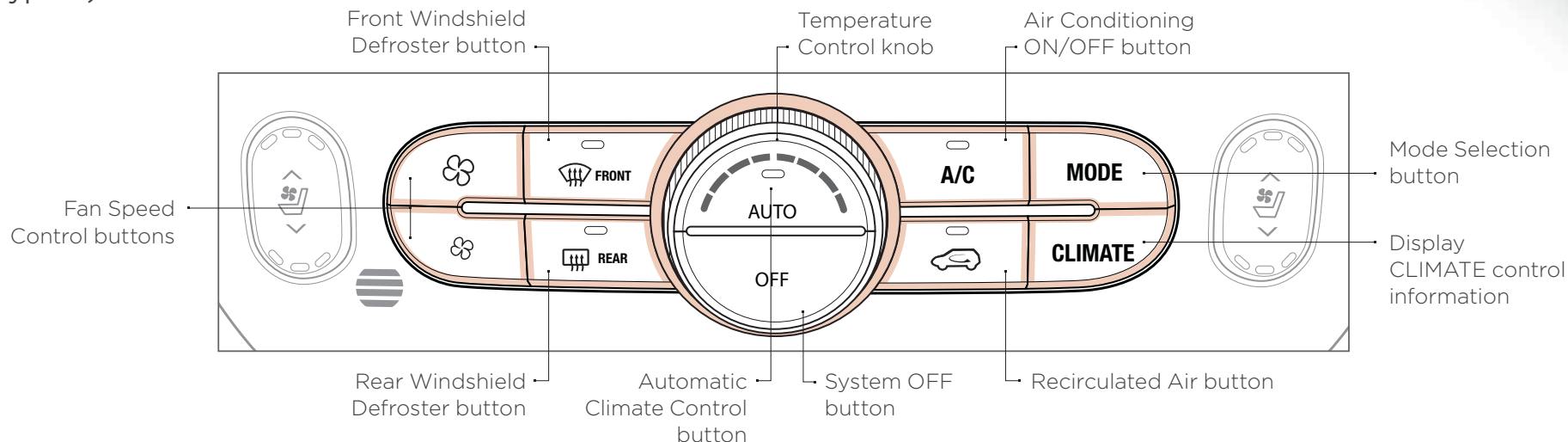

Automatic Climate Control*

(Type B)



Air Flow Modes

To select Air Flow Modes, press the Mode selection buttons:

-  Face-Level
-  Bi-Level
-  Floor-Level
-  Floor/Defrost-Level

Climate Control Auto Function:

1. Press **AUTO** to select Full Auto Operation
2. Press **MODE** buttons to control which vents air flows through

Defrost Outside Windshield:

1. Set **Fan Speed** to the highest position
2. Set **Temperature** to **Hot**
3. Press the **Defrost button** 

Defog Inside Windshield:

1. Set desired fan **Fan Speed**
2. Set desired **Temperature**
3. Press the **Defrost button** 

🕒 QUICK TIPS

- Keep inside glass as clean as possible to reduce window fogging
- Defrost  Mode activates A/C and opens Fresh Air Vent
- During Auto Operation the A/C indicator will NOT illuminate. The fan speed, air intake, air flow and air conditioning may automatically engage at any time to reach desired temperature and reduce humidity

REMINDER: Warm air may flow in through vents if Recirculated Air button is not pressed ON (LED lit).

REMINDER: Your Manual Climate Control system may differ from those in the illustrations. See your Owner's Manual for more details.

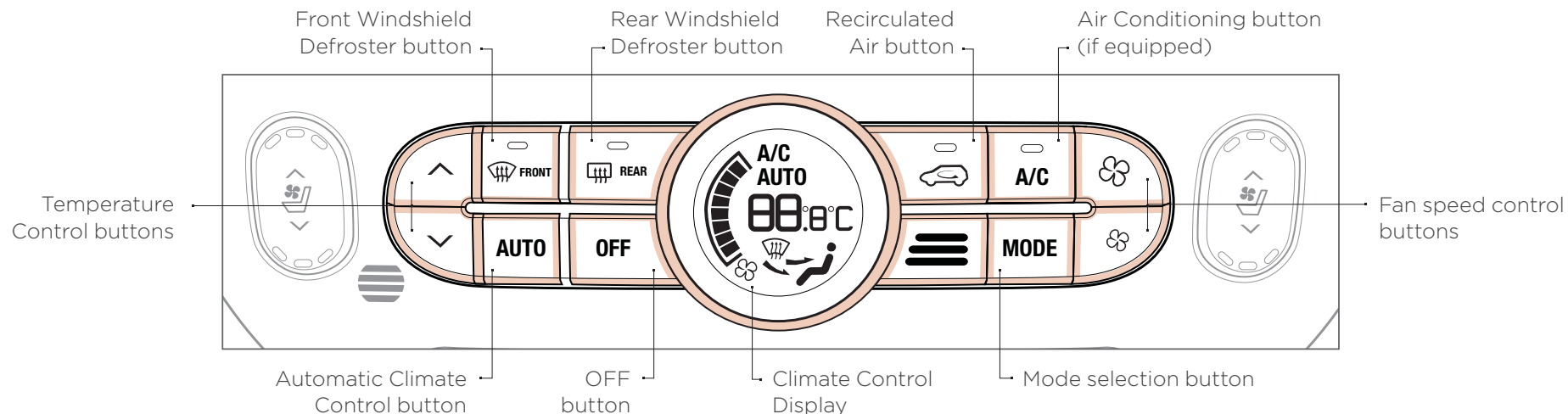

Automatic Climate Control*

(Type A)



Air Flow Modes

To select Air Flow Modes, press the Mode selection buttons:

-  **Face-Level**
-  **Bi-Level**
-  **Floor-Level**
-  **Floor/Defrost-Level**

Climate Control Auto Function:

1. Press **AUTO** to select Full Auto Operation
2. Press **MODE** buttons to control which vents air flows through

Defrost Outside Windshield:

1. Set **Fan Speed** to the highest position
2. Set **Temperature** to **Hot**
3. Press the **Defrost button** 

Defog Inside Windshield:

1. Set desired fan **Fan Speed**
2. Set desired **Temperature**
3. Press the **Defrost button** 

🕒 QUICK TIPS

- Keep inside glass as clean as possible to reduce window fogging
- Defrost  Mode activates A/C and opens Fresh Air Vent
- During Auto Operation the A/C indicator will NOT illuminate. The fan speed, air intake, air flow and air conditioning may automatically engage at any time to reach desired temperature and reduce humidity

REMINDER: Warm air may flow in through vents if Recirculated Air button is not pressed ON (LED lit).



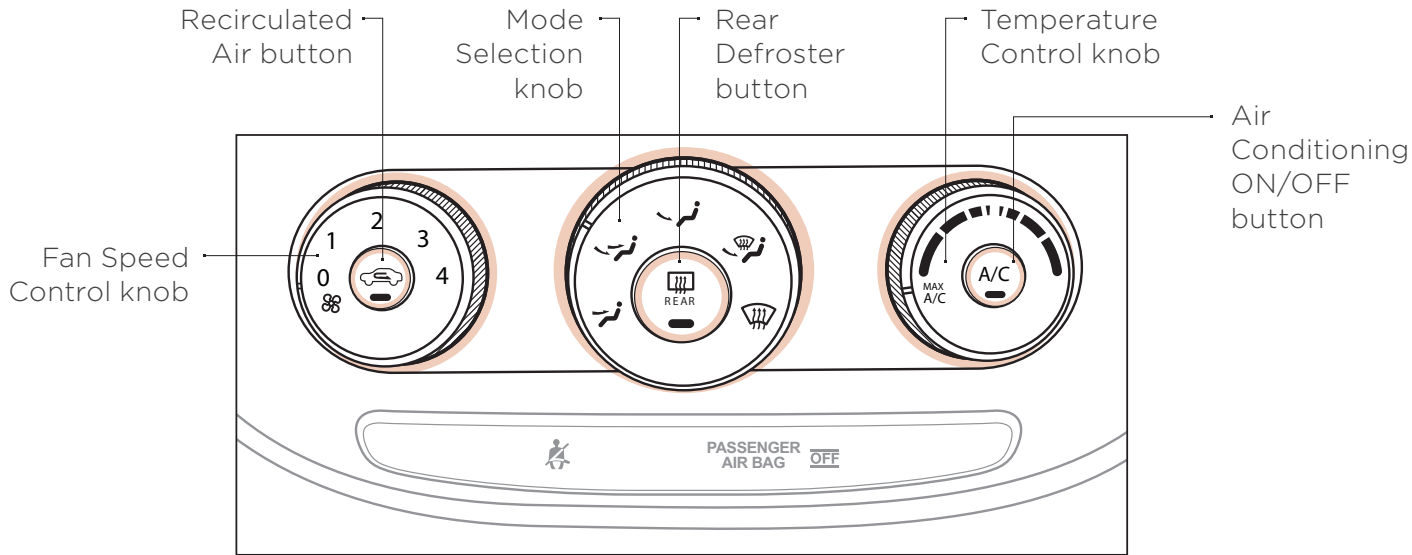

REMINDER: Your Manual Climate Control system may differ from those in the illustrations. See your Owner's Manual for more details.

Manual Climate Control*



Air Flow Modes

To select Air Flow Modes, press the Mode selection buttons:

-  **Face-Level**
-  **Bi-Level**
-  **Floor-Level**
-  **Floor/Defrost-Level**

Defrost Outside Windshield:

1. Set **Fan Speed** to the highest position
2. Set **Temperature** to **Hot**
3. Rotate knob to the **Front Defroster** mode 

Defog Inside Windshield:

1. Set **Fan Speed** to desired position
2. Set desired **Temperature**
3. Rotate knob to the **Front Defroster** mode 

QUICK TIPS

- Defrost  Mode activates A/C and opens Fresh Air Vent
- MAX A/C Mode automatically engages Recirculated Air
- Keep inside glass as clean as possible to reduce window fogging

REMINDER: Warm air may flow in through vents if Recirculated Air button is not pressed ON (LED lit).

REMINDER: Your Manual Climate Control system may differ from those in the illustrations. See your Owner's Manual for more details.

Automatic Gear Shift with Sportmatic® Shifting*

P: Park

R: Reverse

N: Neutral

D: Drive

[+]: Sport Mode Upshift

[-]: Sport Mode Downshift

Sport Mode: To enter Sport Mode, move shift lever from D to left gate

Sport Mode Shifting: Move shift lever up [+] to Upshift or down [-] to Downshift

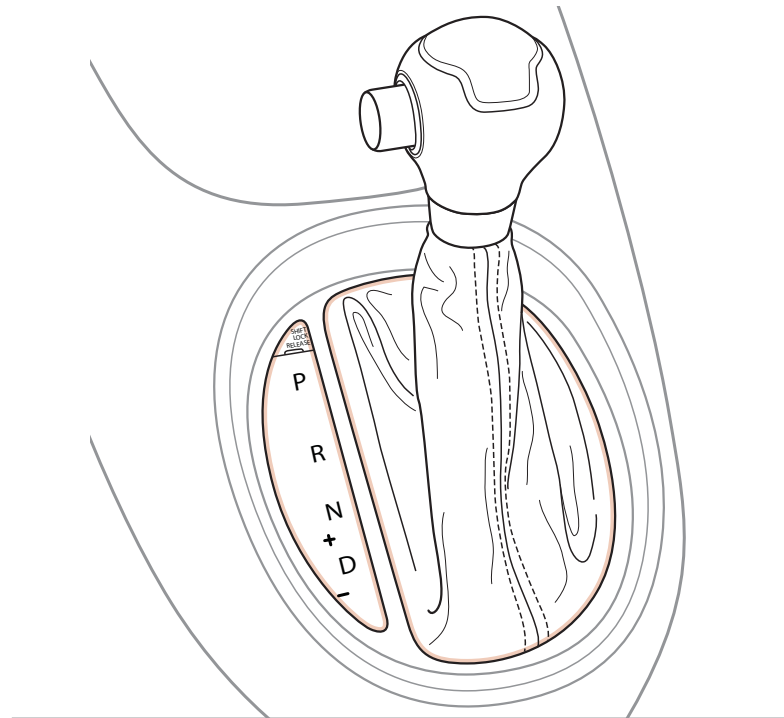

QR CODE

Kia Sportmatic® Shifting Video

To view a video on your mobile device, SNAP this QR Code or visit the listed website.

Refer to page 2 for more information.



www.KuTechVideos.com/ps13/2014

QUICK TIPS

- Press brake pedal and depress release button to move gear shift from N to P, N to R or from P to any gear
- Sport Mode downshifts are made automatically when the vehicle slows down. When the vehicle stops, 1st gear is automatically selected

Manual Gear Shift*

Starting the Engine

1. Pull up to apply Parking Brake **A**
2. Depress Clutch Fully **B**
3. Shift into Neutral **C**
4. Turn Ignition to START

Shifting into Reverse

1. Depress Clutch Fully **B**
2. Shift into Neutral **C**
3. Pull up on Shift Lever Ring **D**
4. Shift into Reverse **E**

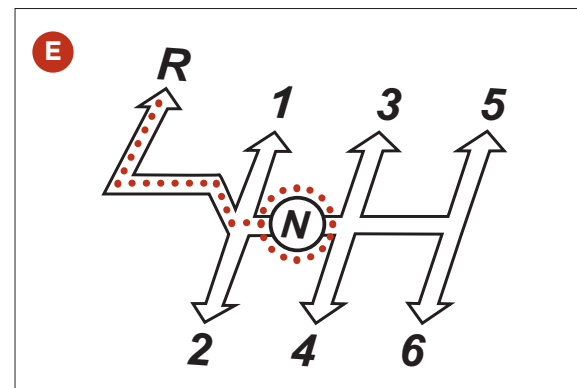
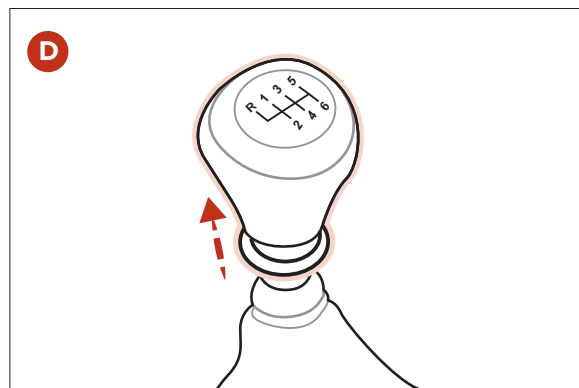
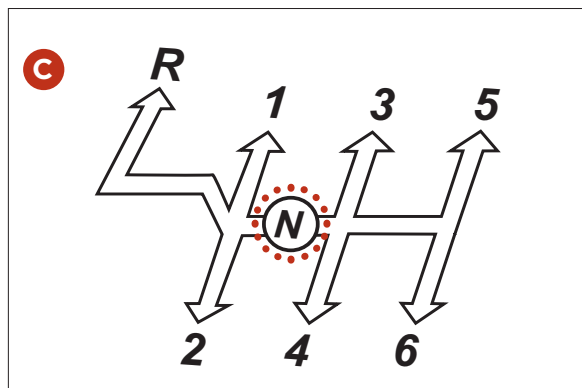
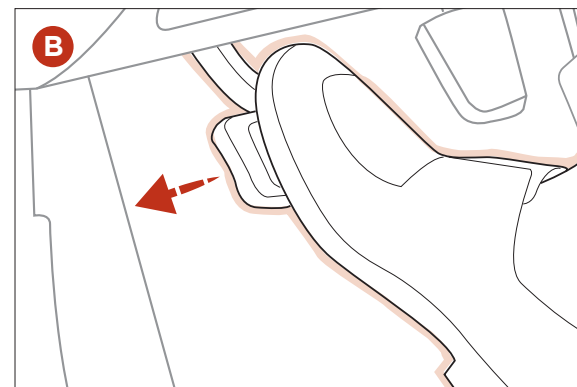
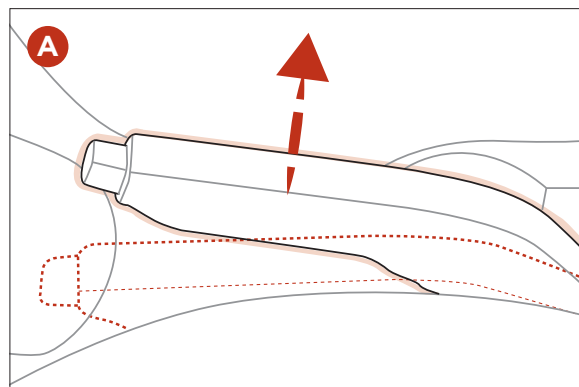

Ⓢ QUICK TIPS

When shifting into gears 1-6, the Shift Lever can be moved without pulling the Shift Lever Ring.

Seat Warmers*

Press button once for high setting (2 LEDs lit). Press button twice for low setting (1 LED lit). Press again to turn OFF.

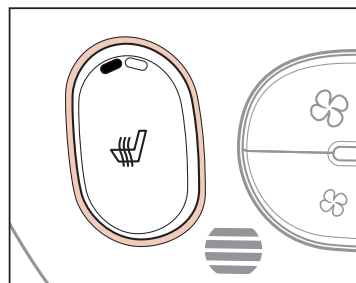

(Type B)

Seat Warmers / Ventilated Seats*

Seat Warmers – Press top of button once for high setting (3 LEDs lit). Press button twice for medium setting (2 LEDs lit). Press a third time for low setting (1 LED lit) and again to turn OFF.

Ventilated Seats – Press bottom of button once for high setting (3 LEDs lit). Press twice for medium setting (2 LEDs lit). Press a third time for low setting (1 LED lit) and again to turn OFF.

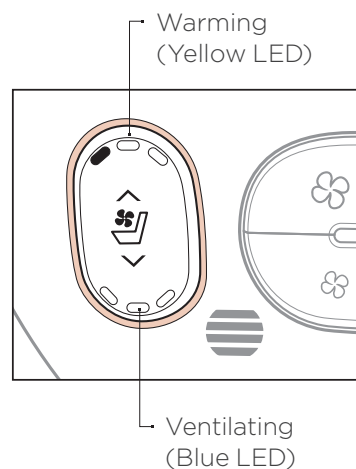

🕒 QUICK TIPS

- System turns OFF when ignition is cycled. To turn system ON, press the seat warmer switch.
- With the seat warmer switch in the ON position, the heating system in the seat turns off or on automatically depending on the seat temperature

6-Way Manual Adjustable Driver's Seat*

Pull lever **A** to slide Seat forward/backward

Pull/press lever **B** to adjust Seat Height

Pull lever **C** to adjust Seatback Recline

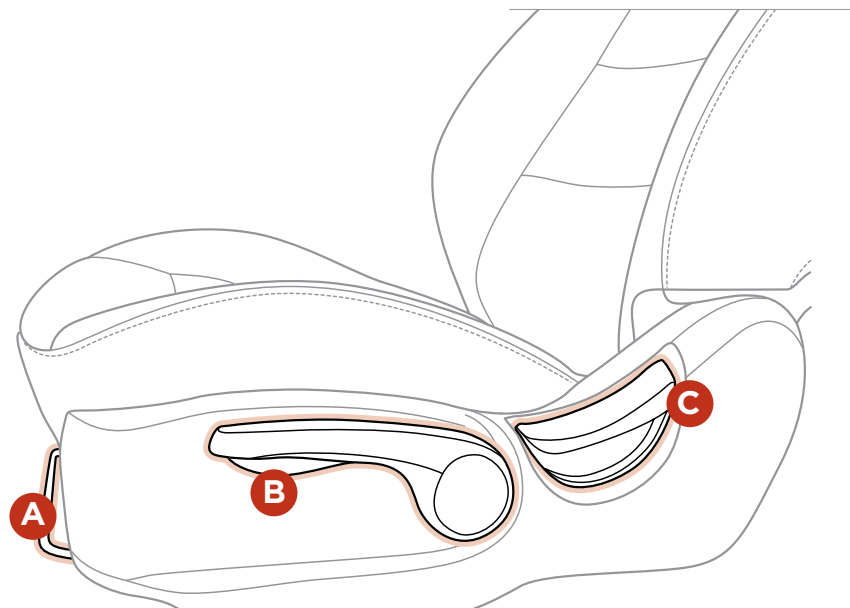

🕒 QUICK TIPS

It may be necessary to adjust the front seatbacks to fully lower rear seats.

Power Adjustable Driver's Seat

Move/Press controls to adjust Seat forward/backward, Seat Cushion, Seatback or Lumbar.

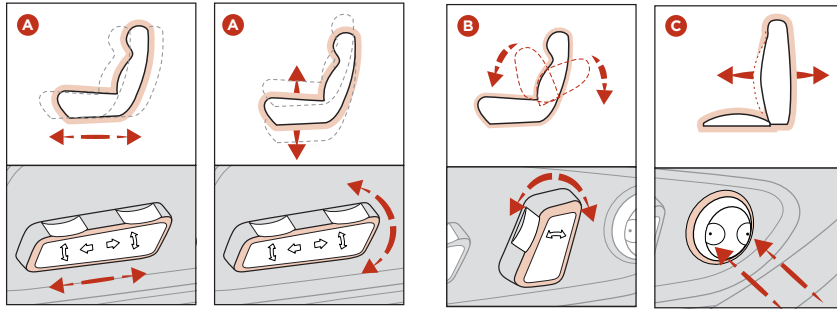

Seat forward/
backward

Seat Cushion

Seatback

Lumbar

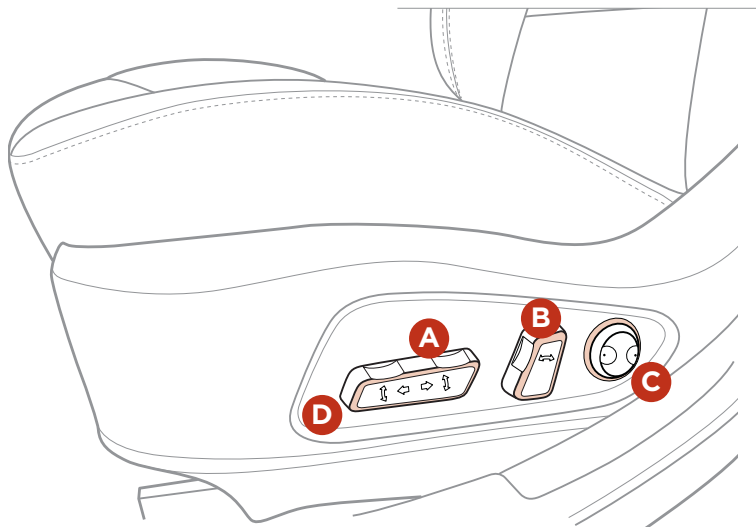

Front Seat Headrest Adjustment

To adjust headrest forward*: Pull headrest forward to one of several positions.

To adjust headrest back*: Pull headrest completely forward, then release.

To raise headrest: Pull headrest up.

To lower headrest: Press lock, then press the headrest down.

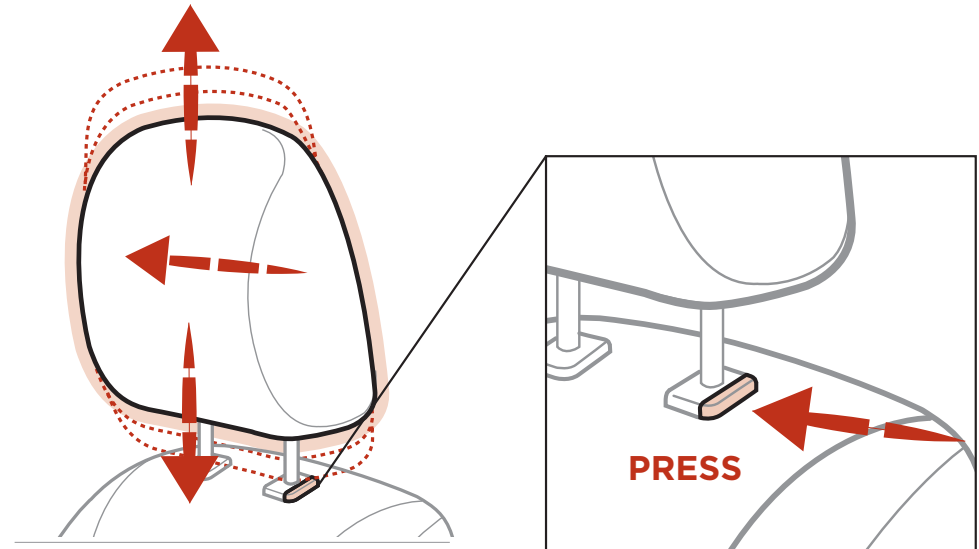

ⓘ QUICK TIPS

For easy adjustments, hold a headrest post with one hand while using the other hand to pull the headrest from underneath.

Fold & Unfold Rear Seatback

To Fold:

1. Adjust the Front Seatback in the upright position and/or slide the Front Seat forward
2. Insert the rear seat belt strap into the clip located on the side panel next to the Seatback
3. Lower the Rear Headrests to the lowest position
4. Pull on the Rear Seatback folding lever **A**, then fold the seat towards the front

REMINDER: Always make sure the seat back is locked in place when unfolded.

To Unfold:

1. Lift and pull the Seatback backward by pulling on the folding lever **A**. Pull the Seatback firmly until it clicks and is locked into place
2. Return the rear seat belt to the proper position

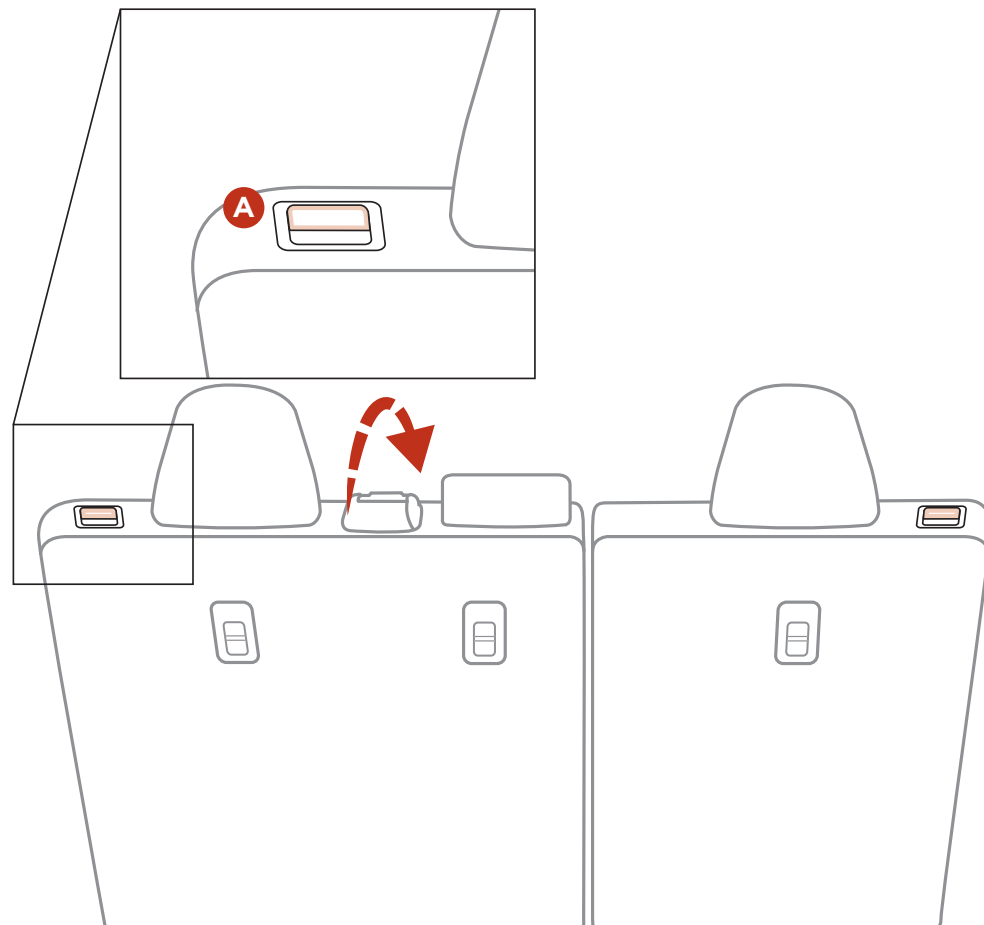

OTHER KEY FEATURES

Smart Key*

Smart Key Fob:

- A** Press to lock All Doors
- B** Press to unlock Driver's Door. Press twice in 4 seconds to unlock All Doors
- C** Press and hold to unlock Rear Hatch and manually open

REMINDER: The Rear Hatch unlocks when the Smart Key fob is within close proximity of the vehicle.

- D** Press and hold more than 1 second for Panic Alarm. To turn off Alarm, press any button
- E** Press to release Mechanical Key (Button located on back of Smart Key)

Mechanical Key **F**:

- Use to unlock driver's door
- Use to turn Child Safety Locks (page number 34)

For more information on the Mechanical Key, please refer to your Owner's Manual.

Driver's Door Lock/Unlock button **G**:

- Press button once to unlock driver's door
- Press again within 4 seconds to unlock all doors
- Press again to lock all doors

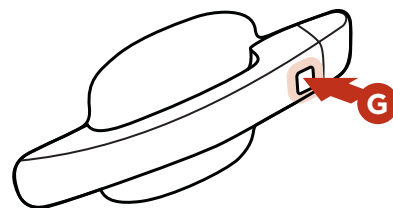
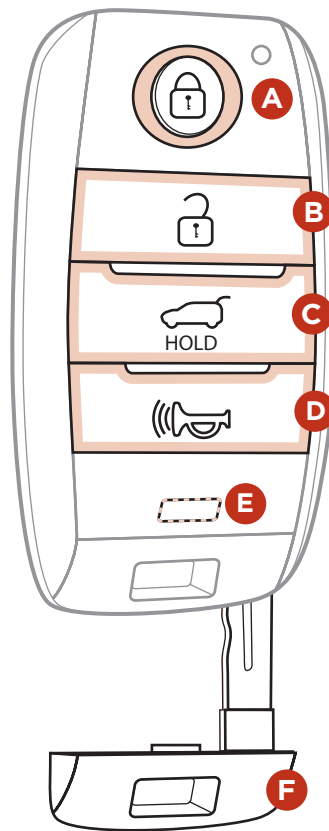

QR CODE

Kia Engine Start/Stop Button & Smart Key Video

To view a video on your mobile device, SNAP this QR Code or visit the listed website.

Refer to page 2 for more information.



www.KuTechVideos.com/ps13/2014

QUICK TIPS

The Smart Key's signal can be blocked by the normal operation of a cell or smart phone. To help prevent this, store each device separately.

REMINDER: Remote button configuration may vary depending on vehicle options.

Remote Keyless Entry*

- A** Press the release button to unfold the key.
- B** Press to Lock All Doors
- C** Press to unlock Driver's Door. Press twice in 4 seconds to unlock All Doors and Rear Hatch
- D** Press and hold to unlock Rear Hatch and manually open
- E** Press and hold more than 1 second for Panic Alarm. To turn OFF Alarm, press any button

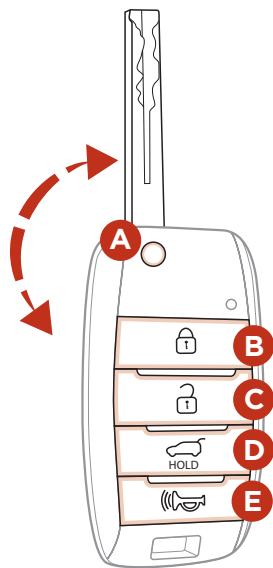

REMINDER: The Rear Hatch does not automatically open when the **D** button is pressed

REMINDER: The Rear Hatch unlocks when the Smart Key fob is within close proximity of the vehicle

REMINDER: Remote button configuration may vary depending on vehicle options.

Double-Turn Lock / Unlock All*

(Only available with Power Door Locks)

- Turn counterclockwise once to unlock Driver's Door
- Turn counterclockwise again within 4 seconds to unlock All Doors
- Turn clockwise once to Lock All Doors

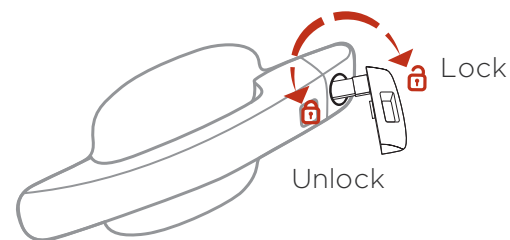

Fuel Cap Open Warning Indicator

Tighten Fuel Cap for ONE CLICK to prevent Fuel Cap Open Warning Indicator from illuminating.

REMINDER: Fuel filler release lever is located on the driver's floor near door sill.

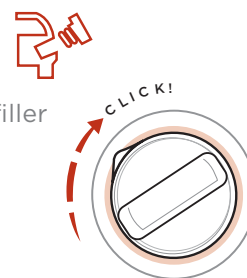

QR CODE

Kia One Click Fuel Cap Video

To view a video on your mobile device, SNAP this QR Code or visit the listed website.

Refer to page 2 for more information.



www.KuTechVideos.com/ps13/2014

OTHER KEY FEATURES

Map/Room Lamps

Push the lens **A** to turn the Map Lamp ON/OFF. This light produces a spot beam for convenient use as a map lamp or personal lamp for the driver or front passenger.

When the DOOR button **B** is pressed, the Map Lamp turns ON when any door is opened.

When the ROOM button **C** is pressed, the Map and Room Lamps turn ON.

Room Lamp

When the Room Lamp button **D** is pressed, the lamp turns ON.

Automatic turn off function*

The interior lights automatically turn off approximately 30 seconds after the Engine System Start/Stop button* is OFF.

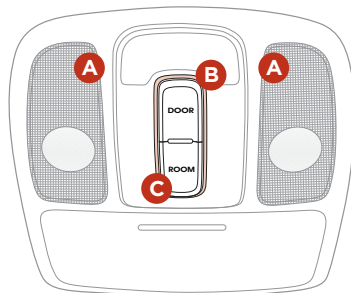

(Type A)

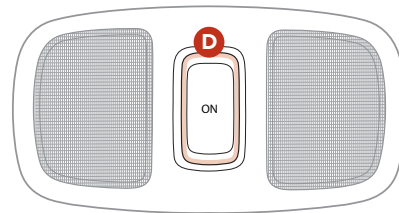

(Type A)

🕒 QUICK TIPS

- When doors are unlocked by the Smart Key*, the lamp turns ON for approximately 30 seconds
- If your vehicle is equipped with the theft alarm system, the interior lights automatically turn off approximately 3 seconds after the system is in armed stage
- Using interior lights for an extended period of time may cause battery discharge

Sunvisor

Use the Sunvisor to shield direct light through the front or side windows. Slide the Sunvisor out and adjust as needed.

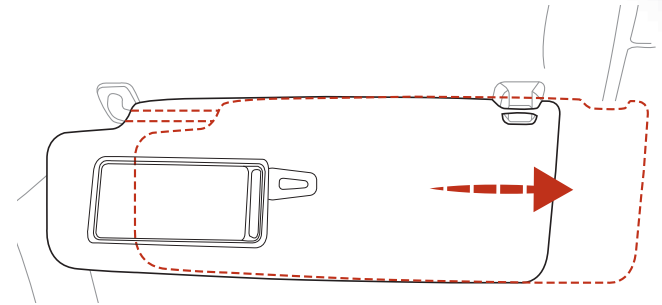

REMINDER: Sunvisor may not shield all direct light.

REMINDER: Do not operate the vehicle if Sunvisor is impairing your visibility.

REMINDER: The Sunvisor may impair visibility if not adjusted properly.

Panoramic Sunroof Operation*

The sunroof operation is controlled through a multidirectional switch/lever and the sunshade is controlled through the OPEN/CLOSE buttons. The ignition needs to be in the ON position to operate the Sunroof and Sunshade.

Slide the Sunshade and Sunroof:

- **Open:** Slide the lever **A** backward
- **Close:** Slide the lever **A** forward

Tilt the Sunroof:

- **Raise:** Push lever **A** upward
- **Lower:** Pull lever **A** downward
- **Auto Close:** Press the CLOSE toggle button **B**

Slide the Sunshade:

- **Open:** Press the OPEN toggle button **B**
- **Close:** Press the CLOSE toggle button **B**

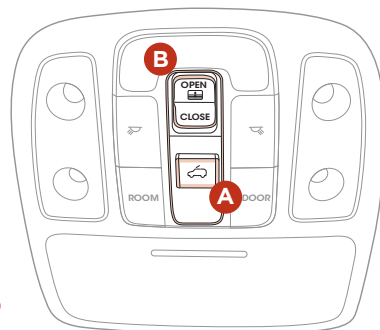

REMINDER: Sunshade needs to remain OPEN while Sunroof is open and vehicle is moving.

ⓘ QUICK TIPS

- To stop the Sunroof/Sunshade at any position, push or pull the sunroof control lever in any direction

Sunroof Open Warning*

If the Sunroof is not fully closed, the warning will chime and display on the LCD screen* when:

- The ignition is turned off (Smart Key*)
- The driver's door is opened
- The ignition key is removed

Rear-Camera Display*

The Rear-Camera Display system is not a safety device. It is a supplemental system that displays the view behind the vehicle through the Navigation System* or UVO* screen while the vehicle is in Reverse.

The Rear-Camera Display activates when the:

1. Engine Start/Stop* button is in the ON position (Green Light)
2. Gear Shift Lever is in the R (Reverse) position

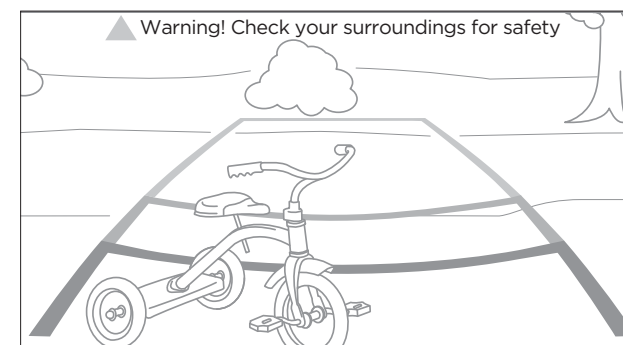

REMINDER:

- The Rear-Camera Display is not a substitute for proper and safe backing-up procedures. The Rear-Camera Display may not display every object behind the vehicle. Always drive safely and use caution when backing up.
- While camera is active, only the volume controls on the Audio System can be operated.

OTHER KEY FEATURES

Tire Mobility Kit*

The Tire Mobility Kit may temporarily seal certain types of tire damage.

For operational information, please refer to section 6 of your Owner's Manual.

A Sealant Bottle

B Compressor

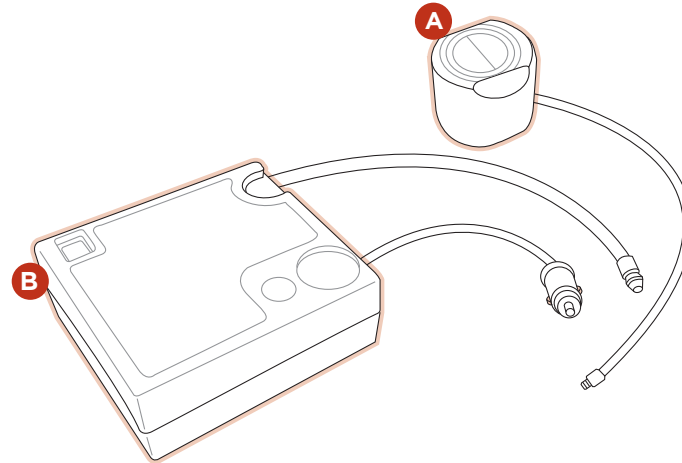

REMINDER: The Tire Mobility Kit requires the use of the **12V/15A/180W** Power Outlet, which is located on the right side of the outlet/aux port area.

REMINDER: After tire is properly sealed, drive cautiously at no more than a total distance speed of 50 mph for no longer than a maximum distance of up to 120 miles.

🕒 QUICK TIPS

- The Tire Mobility Kit is a temporary fix and is to be used for one tire only; the tire should be inspected as soon as possible
- The kit should only be used for sealing/inflating passenger car tires; do not use for inflating any other type of tires
- Some damaged tires cannot be sealed completely; do not use the kit if a tire is damaged beyond repair

📱 QR CODE

Kia Tire Mobility Kit Video

To view a video on your mobile device, SNAP this QR Code or visit the listed website.

Refer to page 2 for more information.



www.KuTechVideos.com/ps13/2014

OTHER KEY FEATURES

Rear Hatch Release Button

Button is located underneath the Rear Hatch lid. With Rear Hatch unlocked, press the Rear Hatch Release button **A** and pull the Rear Hatch lid up by the handle to open.

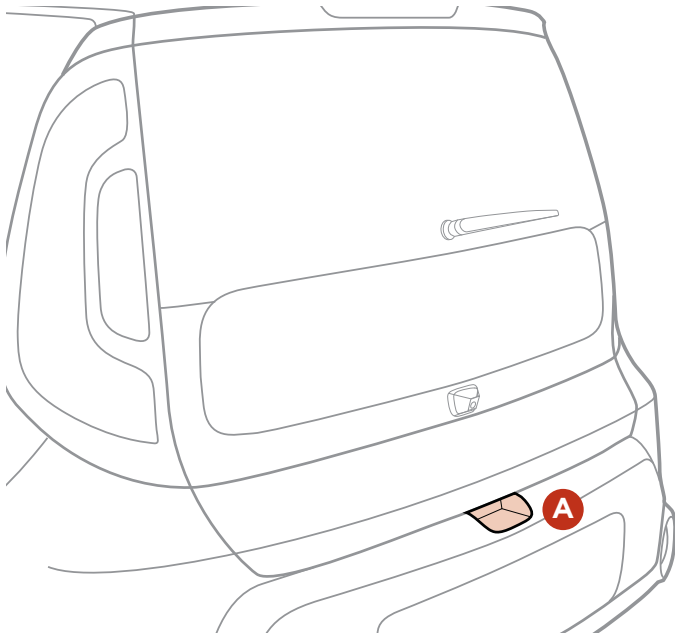

🕒 QUICK TIPS

- The Rear Hatch must be unlocked before it can be opened by the Rear Hatch Release Button
- The Rear Hatch unlocks automatically and then can be opened manually when the Smart Key* is within close proximity to the vehicle

Child Safety Locks

Located on the rear edge of the rear passenger doors, adjust switch **A** to the LOCK position to disable the inner door handles from opening the rear doors.

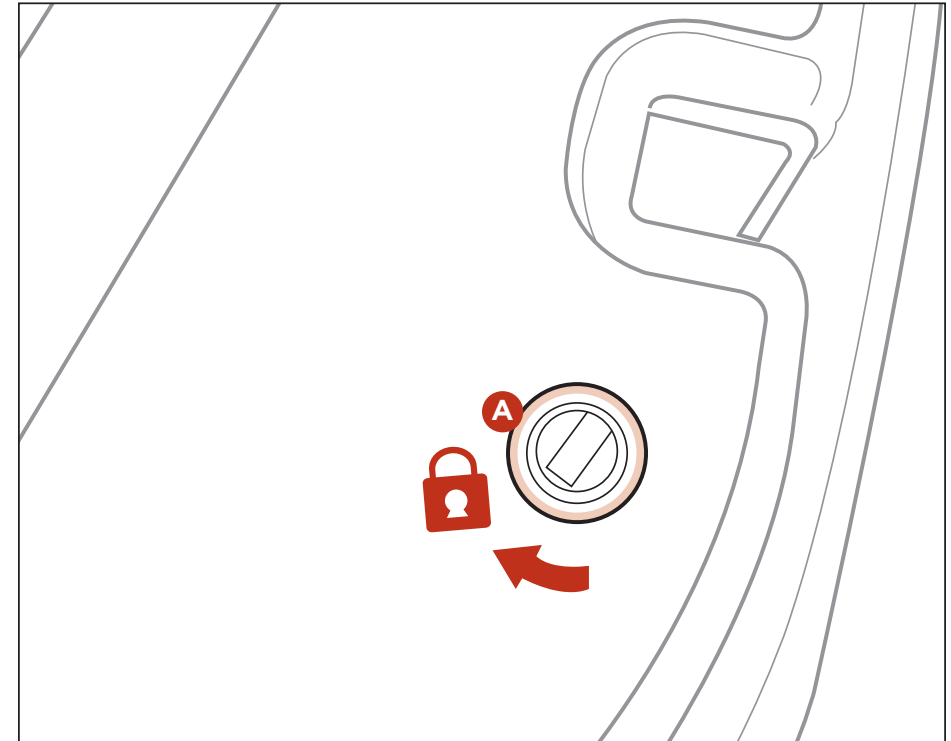

REMINDER: Child Safety Lock is located on rear passenger's door jamb.

Please refer to your Owner's Manual and the separate brochure titled "Understanding Your Safety Belt & Supplemental Restraint System" for more detailed information regarding your vehicle's airbags.

Occupant Detection System (ODS) / PASSENGER AIRBAG OFF Indicator

ODS detects the presence and position of the front passenger and adjusts or turns off airbag deployment accordingly.

Depending on the situation and type of accident, the system may:

- Deploy airbag (Adult)
- Not deploy the airbag (Unoccupied)

If the system determines that the airbag should not be deployed, the “PASSENGER AIRBAG OFF” light will illuminate.



QR CODE

Kia Occupant Detection System Video

To view a video on your mobile device, SNAP this QR Code or visit the listed website.

Refer to page 2 for more information.



www.KuTechVideos.com/ps13/2014

Safety Belts

To properly fasten your safety belts:

1. Insert the tongue belt plate **A** into the buckle **B** until it clicks
2. Position the lap portion of the belt across your lap as **LOW ON THE HIPS** as possible **C**. Adjust the belt to a **SNUG FIT** by pulling up on the shoulder portion **D**.

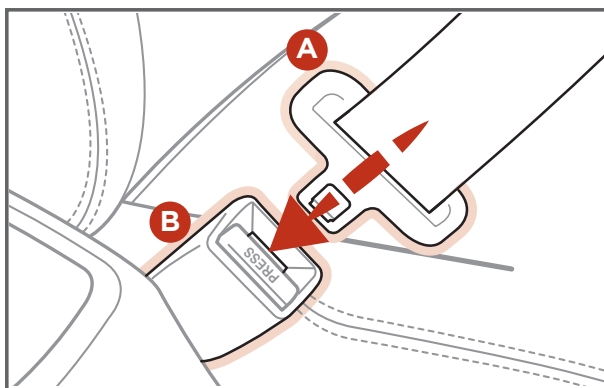

Safety Belt Retractor Inertial Locks

- Inertial locks allow lap/shoulder safety belts to remain unlocked during normal vehicle operation for freedom of movement and increased comfort
- During a **STRONG STOP, SUDDEN TURN OR CERTAIN COLLISION**, safety belt retractors will automatically lock the belts

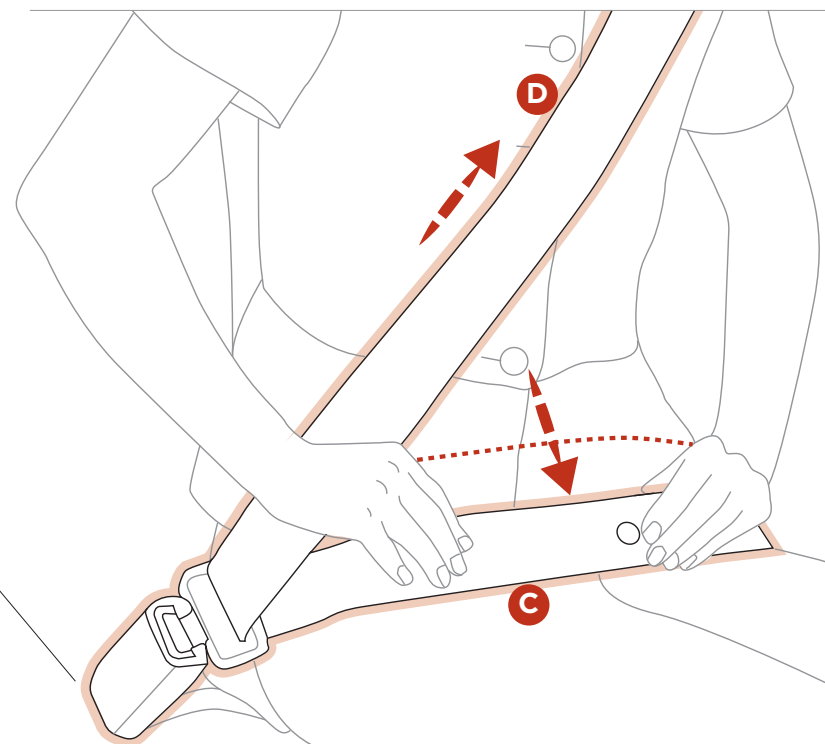

Ⓢ QUICK TIPS

The Safety Belt warning chime operates for driver's seat only.

For more detailed information regarding your vehicle's safety belts, please refer to your Owner's Manual and the separate brochure titled "Understanding Your Safety Belt & Supplemental Restraint System".

LEGAL DISCLAIMERS

UVO eServices: Warning - Driving while distracted can result in a loss of vehicle control that may lead to an accident, severe personal injury, and death. The driver's primary responsibility is in the safe and legal operation of a vehicle, and use of any handheld devices, other equipment, or vehicle systems which take the driver's eyes, attention and focus away from the safe operation of a vehicle or which are not permissible by law should never be used during operation of the vehicle.

TPMS: Even with the Tire-Pressure Monitoring System (TPMS), always check your tire pressure on a regular basis.

The Rear-Camera Display is not a substitute for proper and safe backing-up procedures. The Rear-Camera Display may not display every object behind the vehicle. Always drive safely and use caution when backing up.

The Blind Spot Detection System is not a substitute for proper and safe lane changing procedures. Always drive safely and use caution when changing lanes. The Blind Spot Detection System may not detect every object alongside the vehicle.

Driving while distracted is dangerous and should be avoided. Drivers should remain attentive to driving and always exercise caution when using the steering-wheel-mounted controls while driving.

Seatbelts: For maximum protection, always wear your seatbelt.

Navigation: GPS maps and directions are for information purposes only, and Kia does not make any warranties about the accuracy of that information. Kia is not responsible for loss or delay resulting from the use of the navigation system. Caution: Do not enter information into the navigation system while the vehicle is moving. Failure to pay attention to travel conditions and vehicle operation while the vehicle is in motion could result in loss of vehicle control. Operate the system only when it is safe to do so.

At launch, the Apple iPhone® will be the only UVO eServices compatible device. iPhone® is a registered trademark of Apple Inc. Apple iOS 6 compatibility expected early 2013. Additional compatible devices expected late 2013.

iPod® is a registered trademark of Apple Inc. iPod® mobile digital device sold separately.

The Bluetooth® word mark and logos are registered trademarks owned by Bluetooth SIG, Inc. and any use of such marks by Kia is under license. Other trademarks and trade names are those of their respective owners. A Bluetooth® enabled cell phone is required to use Bluetooth® wireless technology.

SiriusXM Satellite Radio, SiriusXM Traffic and SiriusXM Travel Link each require a subscription sold separately, or as a package, by SiriusXM Radio Inc. If you decide to continue your service at the end of your trial subscription, the plan you choose will automatically renew and bill at then-current rates until you call 1-866-635-2349 to cancel. See SiriusXM Customer Agreement for complete terms at www.siriusxm.com. Other fees and taxes will apply. All fees and programming are subject to change. Not all vehicles or devices are capable of receiving all services offered by SiriusXM. Data displays and individual product availability vary by vehicle hardware. Current information and features may not be available in all locations, or on all receivers. Weather Forecast, Current Conditions may not be available in all locations. Images above are for representative purposes only and are not real products. For actual features and images of real products, consult the vehicle manufacturer. SiriusXM is not responsible for any errors or inaccuracies in the data services or their use in the vehicle. Travel Link Stocks displays current price and daily delta of around 7,000 actively reported securities traded on the NYSE®, NASDAQ® and AMEX®. The service is delayed approximately 20 minutes. SiriusXM satellite service is available only to those at least 18 years of age in the 48 contiguous USA, DC, and Puerto Rico (with coverage limitations). SiriusXM Internet Radio service is available throughout our satellite service area and in AK and HI. © 2013 SiriusXM Radio Inc. Sirius, XM and all related marks and logos are trademarks of SiriusXM Radio Inc.

Microsoft® is a registered trademark of Microsoft Corporation in the United States and/or other countries.

HD Radio™ and the HD Radio logo are proprietary trademarks of iBiquity Digital Corporation.

HomeLink® is a registered trademark of Johnson Controls, Inc.



NORMAL MAINTENANCE SCHEDULE

When your vehicle requires service, remember that your dealer knows your vehicle best. Your dealer has factory-trained technicians, recommended special tools, genuine Kia replacement parts, and is dedicated to your complete satisfaction. For expert advice and quality service, see your authorized Kia dealer.

INTERVAL MAINTENANCE CHART							
7,500 miles	A						
15,000 miles	A	B					
22,500 miles	A						
30,000 miles	A	B	C				
37,500 miles	A			D			
45,000 miles	A	B					
52,500 miles	A						
60,000 miles	A	B	C		E		
67,500 miles	A						
75,000 miles	A	B		D	E		
82,500 miles	A						
90,000 miles	A	B	C		E		
97,500 miles	A						
105,000 miles	A	B		D	E	F	
112,500 miles	A						
120,000 miles	A	B	C		E		G

A Inspect*: Air cleaner filter, brake lines, hoses and connections, disc brakes and pads**, drum brakes and linings**, brake pedal and operation, brake fluid, clutch fluid**, exhaust pipe and muffler, chassis/body nuts and bolts, steering operation and linkage, suspension mounting bolts, drive shaft and boots, air conditioning compressor, air conditioning refrigerant/performance**, cooling system¹, battery condition, front suspension ball joints, fuel tank, fuel cap, fuel lines, fuel hoses, lubricate all locks and hinges, parking brakes

Replace: Engine oil, engine oil filter

Perform: Rotate tires; add fuel additive[†]

B Replace: Climate control air filter**

C Inspect*: Fuel tank air filter (CCV filter)², fuel filter², vapor hose and fuel filler cap

Replace: Air cleaner filter

D Inspect*: Manual transmission fluid**

E Inspect*: Drive belt³ — then every 15,000 miles afterwards. At 60,000 and 120,000 miles, also inspect valve clearance⁴ (1.6 Engine)

F Replace: Spark plugs**

G Inspect: Cooling System¹

Replace: Engine coolant^{5***}

* and, if necessary, adjust, clean, replace or correct

** If equipped

*** Check and adjust level and check for leaks. Inspect regularly

Check tire pressure once a month or more.

Transfer case oil and rear differential oil should be changed anytime they have been submerged in water.

† If TOP TIER detergent gasoline is not available, one bottle of additive is recommended. Additives are available from your authorized Kia dealer along with information on how to use them. Do not mix other additives.

¹ Inspect "Water Pump" when replacing the drive belt or timing belt.

² Fuel filter & fuel tank air filter are considered to be maintenance free but periodic inspection is recommended for this maintenance schedule depends on fuel quality. If there are some important safety matters like fuel flow restriction, surging, loss of power, hard starting problem etc, replace the fuel filter immediately regardless of maintenance schedule and consult an authorized Kia dealer for details.

³ The drive belt should be replaced when cracks occur or tension is reduced excessively.

⁴ Inspect for excessive tappet noise and/or engine vibration and adjust if necessary.

⁵ When replacing coolant, use only a qualified coolant additive for your vehicle and never mix hard water in the coolant filled at the factory. An improper coolant mixture can result in serious malfunction or engine damage.

See your owner's manual for more details and complete maintenance information, including severe maintenance schedule.

Warranty may be voided if maintenance schedule is not followed.

Call 1-800-333-4kia (4542) for roadside assistance.



SOUL CUSTOMER DELIVERY CHECKLIST

Owner's Name: _____ VIN: _____ Mileage: _____

Dealership Name: _____ Sales Consultant: _____ Date: _____

BEFORE DELIVERY

- Confirm "Good Battery" with Kia battery tester
- Verify all tire pressures are to spec (see driver's door label) LF_____ LR_____ RF_____ RR_____
- Verify proper operation of Remote Keyless Entry and Smart Key lock/unlock
- Ensure floor mats are snapped into place (if applicable)
- Verify vehicle is clean (interior and exterior), in good condition, free of chips and scratches
- Ensure all key documents are in the vehicle (Owner's Manual, Warranty and Consumer Information booklet, Tire Warranty booklet, and Features & Functions Guide and any supplemental audio user's guides)

KEY FEATURE WALKTHROUGH

- Air Conditioning / Climate Control – pages 21-23
Demonstrate Air Flow Modes, Defog and Defrosting Windshield

Automatic*

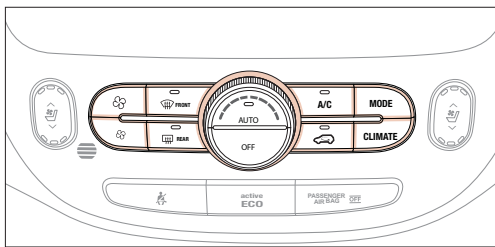

Manual*

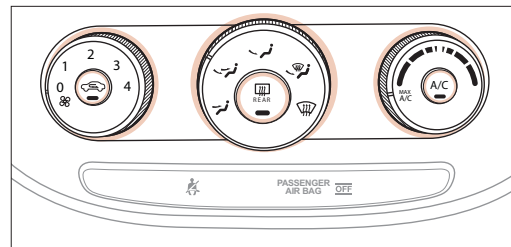

- Manual Gear Shift* – page 25
Demonstrate lifting ring for reverse gear

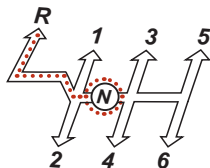
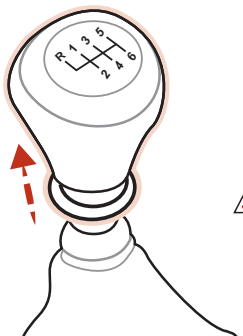

- Windshield/Rear Wipers & Washers – page 11

Rotate level to adjust Intermittent Wipe Speed.

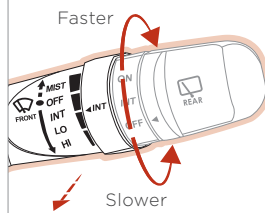

Pull to spray and wipe.

- MIST:** Single wipe
- OFF:** Wiper off
- INT:** Intermittent wipe
- LO:** Slow wipe
- HI:** Fast wipe

Move lever Up/Down to change Wiper modes.

Push to spray and wipe.

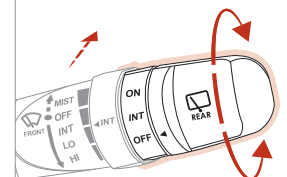

- ON:** Normal wipe
- INT:** Intermittent wipe
- OFF:** Wiper Off

*IF EQUIPPED



KEY FEATURE WALKTHROUGH

Demonstrate the following with the customer

- Standard Audio System – pages 16-17

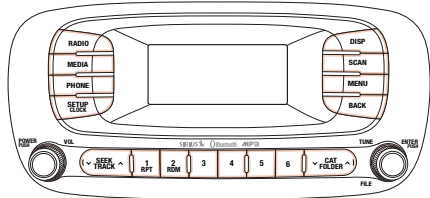

- UVO System* – pages 18
For further UVO System information, refer to the UVO System User’s Manual.

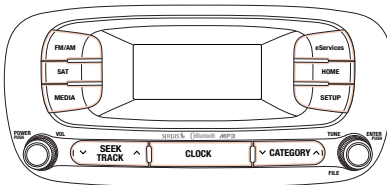

- Navigation System* – page 19
For further Navigation System operation, refer to the Digital Navigation System User’s Manual.

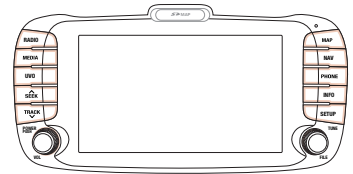

- AUX/USB/iPod® Port – page 20

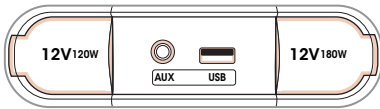

- Cruise Control* – page 13
Demonstrate operation

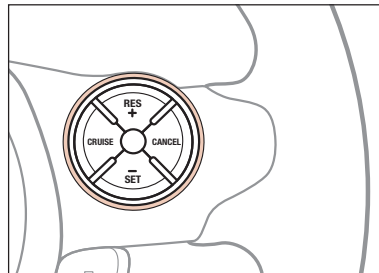

- Bluetooth® Wireless Technology – page 14
Demonstrate operation

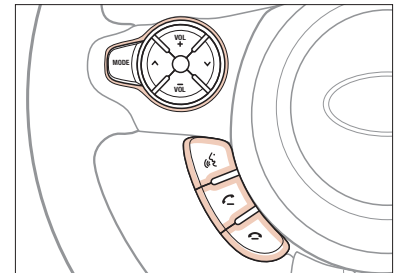

- Active ECO System* – page 6
- Tire Pressure Monitoring System (TPMS) – page 3
- Engine Start/Stop Button* – page 9
- Digital Clock* – page 20
- Seat Warmers / Ventilated Seats* – page 26
- Fold & Unfold Rear Seatback – page 28

- Panoramic Sunroof Operation* – page 32
- Rear-Camera Display* – page 32
- Smart Key* – page 29
- PASSENGER AIRBAG OFF Indicator – page 35
- Tire Mobility Kit – page 33
- ISG (Idle, Stop, Go) System* – page 7

*IF EQUIPPED

DURING DELIVERY

- Explain first service process and schedule first service appointment
- Tour Parts & Service departments, introduce staff & explain value of Kia Parts and Service
- Review recommended maintenance schedule and maintenance requirements to validate warranty
- Review business hours & Customer 360° Care
- Review the Kia 10-year/100,000-mile warranty program
- Ensure 100% satisfaction with sales and delivery process and no problems with the vehicle
- Confirm time and best contact number for initial dealer follow-up

Sales Consultant: _____ Date: _____

Sales Manager: _____ Date: _____

Customer: _____ Date: _____