

# **Nokia M1122**

**ADSL Router**

**T66280**

**ADMINISTRATOR MANUAL**



**NOKIA**

# **M1122**

## **ADSL Router**

### Administrator Manual

#### C33906.20 A0

**NOKIA**

© COPYRIGHT Nokia Networks Oy 2000  
All rights reserved.

No part of this publication may be copied, distributed, transmitted, transcribed, stored in a retrieval system, or translated into any human or computer language without the prior written permission of Nokia Networks Oy.

The manufacturer has made every effort to ensure that the instructions contained in the documents are adequate and free of errors and omissions. The manufacturer will, if necessary, explain issues which may not be covered by the documents. The manufacturer's liability for any errors in the documents is limited to the correction of errors and the aforementioned advisory services.

The documents have been prepared to be used by professional and properly trained personnel, and the customer assumes full responsibility when using them. The manufacturer welcomes customer comments as part of the process of continual development and improvement of the documentation in the best way possible from the user's viewpoint. Please submit your comments to the nearest Nokia sales representative.

NOKIA is a registered trademark of Nokia Corporation.

Any other trademarks mentioned in the documents are the property of their respective owners.

## Document History

Document	Date	Comment
C33906001SE_00	13.09.2000	



# Contents

<b>Chapter 1</b>	
<b>Introduction to Nokia M1122 .....</b>	<b>1-1</b>
<b>Chapter 2</b>	
<b>Applications and features .....</b>	<b>2-1</b>
<b>2.1 Applications .....</b>	<b>2-1</b>
Internet access .....	2-1
Remote work .....	2-3
LAN interconnection .....	2-4
<b>2.2 Features .....</b>	<b>2-4</b>
2.2.1 Interfaces .....	2-4
LAN interfaces .....	2-6
Internal host/gateway interface .....	2-7
Data VCC operation .....	2-7
2.2.2 Routing .....	2-7
2.2.3 Bridging .....	2-7
2.2.4 Network Address Port Translation .....	2-8
2.2.5 Dynamic Host Configuration Protocol .....	2-9
2.2.6 ATM and ADSL .....	2-9
2.2.7 Point-to-Point Tunneling Protocol (PPTP) .....	2-10
2.2.8 Point-to-Point Protocol over Ethernet (PPPoE) .....	2-11
2.2.9 Payload encapsulations .....	2-11
2.2.10 Weighted Fair Queueing (Class of Service) .....	2-11
2.2.11 Management .....	2-12
2.2.12 Dedicated management channel .....	2-12

## Chapter 3

<b>Interfaces and indicator lights</b> .....	<b>3-1</b>
<b>3.1 Interfaces</b> .....	<b>3-1</b>
3.1.1 Ethernet interface .....	3-2
3.1.2 ADSL interface .....	3-2
<b>3.2 Command line interface</b> .....	<b>3-3</b>
<b>3.3 Indicator lights</b> .....	<b>3-4</b>

## Chapter 4

<b>Installing Nokia M1122</b> .....	<b>4-1</b>
<b>4.1 M1122 default settings</b> .....	<b>4-1</b>
<b>4.2 Step-by-step installation procedure</b> .....	<b>4-3</b>

## Chapter 5

<b>Managing M1122</b> .....	<b>5-1</b>
<b>5.1 Operational examples</b> .....	<b>5-1</b>
5.1.1 Routing/tunneling IP only .....	5-2
5.1.2 Routing/tunneling IP, bridging other protocols .....	5-2
5.1.3 Routing/tunneling IP, bridging all protocols including IP ..	5-3
5.1.4 Bridging only .....	5-4
<b>5.2 Typical configuration tasks</b> .....	<b>5-4</b>
5.2.1 Configuring DHCP and DNS .....	5-4
5.2.2 Configuring static and dynamic routing .....	5-5
5.2.3 File system and downloading new firmware using TFTP ..	5-6
Downloading configuration or application from monitor	5-7
<b>5.3 Browser management</b> .....	<b>5-8</b>
5.3.1 Opening a connection .....	5-9
5.3.2 Main Page .....	5-10
5.3.3 Service Providers pages .....	5-11
5.3.4 Local Network pages .....	5-13
Local ports .....	5-13
DHCP .....	5-13
NAPT .....	5-16
Routing page .....	5-17
5.3.5 Statistics page .....	5-18
5.3.6 Restart page .....	5-19
5.3.7 Save Config page .....	5-20

<b>5.4</b>	<b>Command line interface (CLI)</b> .....	<b>5-20</b>
5.4.1	Main mode commands .....	5-23
5.4.2	Configuration mode commands .....	5-44
	Root level commands .....	5-45
	System level commands .....	5-46
	Password level command .....	5-47
	Ethernet level commands .....	5-48
	VCC (ATM channel) commands .....	5-50
	Vbridge commands .....	5-55
	Dedicated management channel commands .....	5-56
	Common commands .....	5-57

## **Appendix A**

	<b>Technical specifications</b> .....	<b>A-1</b>
<b>A.1</b>	<b>Mechanical construction and power supply</b> .....	<b>A-3</b>
<b>A.2</b>	<b>Ambient conditions, EMC and safety</b> .....	<b>A-3</b>
	Ambient conditions .....	A-3
	EMC .....	A-3
	Safety .....	A-4

## **Glossary**





## Chapter 1

# Introduction to Nokia M1122

Nokia M1122 is an integrated ADSL (Asymmetric Digital Subscriber Line) bridge and router which enables high-speed Internet access for your Ethernet local area network (LAN). It multiplies the capacity of the already installed telephone lines used traditionally for telephone and dial-up modem services. M1122 brings high-speed connections available for home users, small offices and telecommuters.



**Figure 1-1** Nokia M1122

M1122 allows you to connect your desktop and laptop PCs to remote networks. Your PCs must be equipped with a 10Base-T Ethernet interface. M1122 has an in-built 4-port hub, which allows easy home network installation.

The ADSL high-speed Internet access may be delivered to you over the same copper pair of wires that is used for your traditional telephony

services. As both services utilise the same pair of wires, a filter is needed to separate them. This is called a POTS filter and it is a small external device connected between your telephone and the telephone wall socket.

Your Nokia M1122 interconnects with a Digital Subscriber Line Access Multiplexer (DSLAM) installed and maintained by your access provider in their central office. M1122 ADSL technology is based on Discrete Multitone (DMT) modulation allowing a maximum of 8 Mbit/s data transmission from the network and 800 kbit/s towards the network. However, these figures illustrate the maximum performance of the technology and are subjected to the physical line conditions and the distance from you to the central office. M1122 is capable of adapting to the physical line conditions and guarantees the maximum transmission rate possible on the particular line. M1122 adapts its speed to the line conditions in steps of 32 kbit/s. In addition to these physical limitations affecting your data throughput, your Internet Service Provider (ISP) may limit your access according to their service provisioning policy and based on your service contract.

---

## Chapter 2

# Applications and features

In this chapter, we present the most common applications and features of M1122. The use and configuration of your Nokia M1122 may be different from the configurations presented in this manual, even for similar applications. The configurations presented in this manual represent a typical way of using M1122 for the corresponding applications.

### 2.1 Applications

The three typical applications discussed below are the Internet access, remote work, and office LAN interconnection.

#### **Internet access**

Your access to the Internet is provided by your Internet Service Provider (ISP). Nokia M1122 connects you through your telephone line and the ATM (Asynchronous Transfer Mode) network to the network of your ISP, which, in turn, is connected to the Internet. Hence, all your data goes through the ISP's network. If you are using only one ISP for your Internet access, your ISP may give you a limited set of IP addresses belonging to its address space that you may utilise in your desktop and laptop computers on your home network.

However, in many cases it is more practical to separate your own private LAN from the ISP's public network by using private IP addresses. This way you are not limited to the number of public IP addresses provided by your ISP but you can manage your own address space independently. For this you will need to use NAT (Network Address Port Translation) feature available in your M1122 modem.

This mode of operation reduces the need to have more than one public Internet address. Furthermore, it prevents others from seeing and accessing your private network and therefore it acts as a simple firewall.

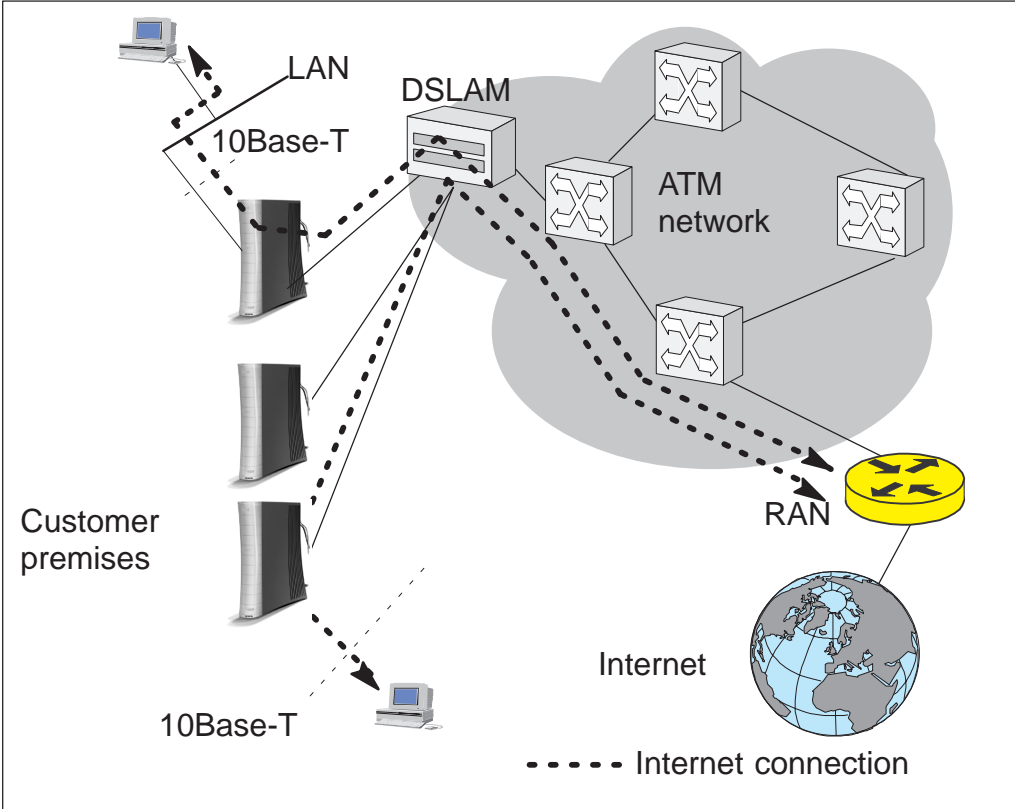
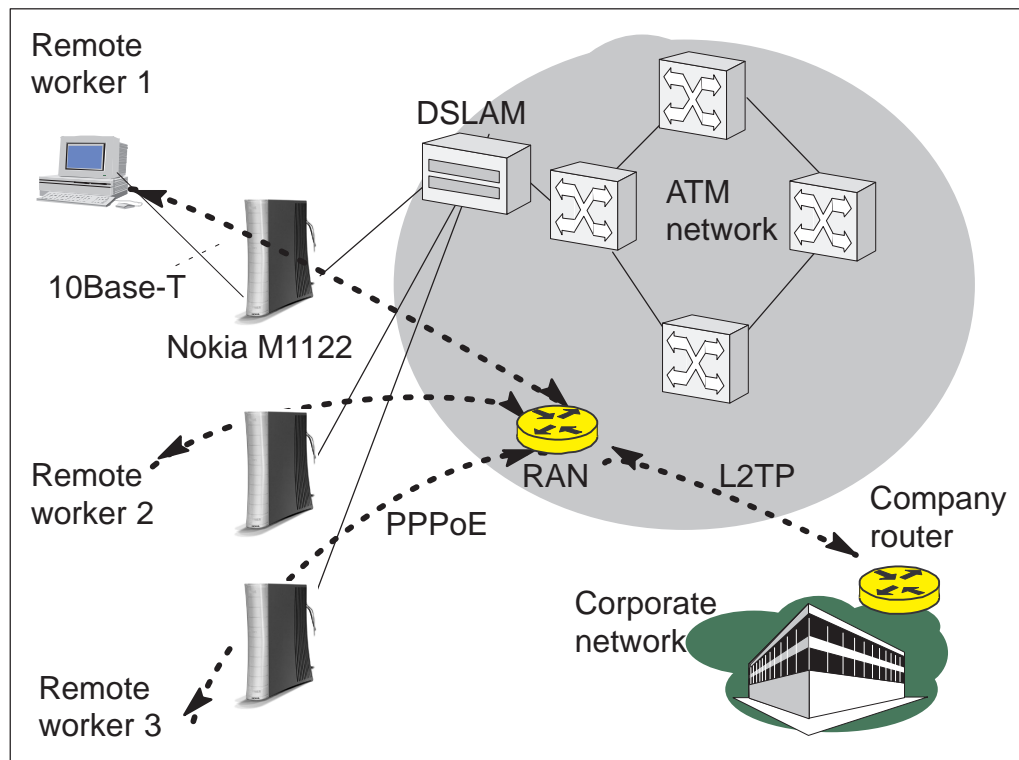

Figure 2-1 High-speed Internet access

**Remote work**

Another application for M1122 is remote work. In this case the end-to-end architecture can, for example, use PPP over Ethernet, where a dial-up-type PPP connection is created between your home PC and your corporate networks PPP access server based on the user name and password you issue in your PC. The same set up could be used for accessing the public Internet with a different user name and password. This example naturally presumes that your ISP supports this type of approach for providing remote work services for our company.



**Figure 2-2** Remote work using M1122 as a standard router

## LAN interconnection

M1122 can also be used for corporate branch office LAN interconnection. As a bridge, M1122 enables all network protocols to be used on the corporate network.

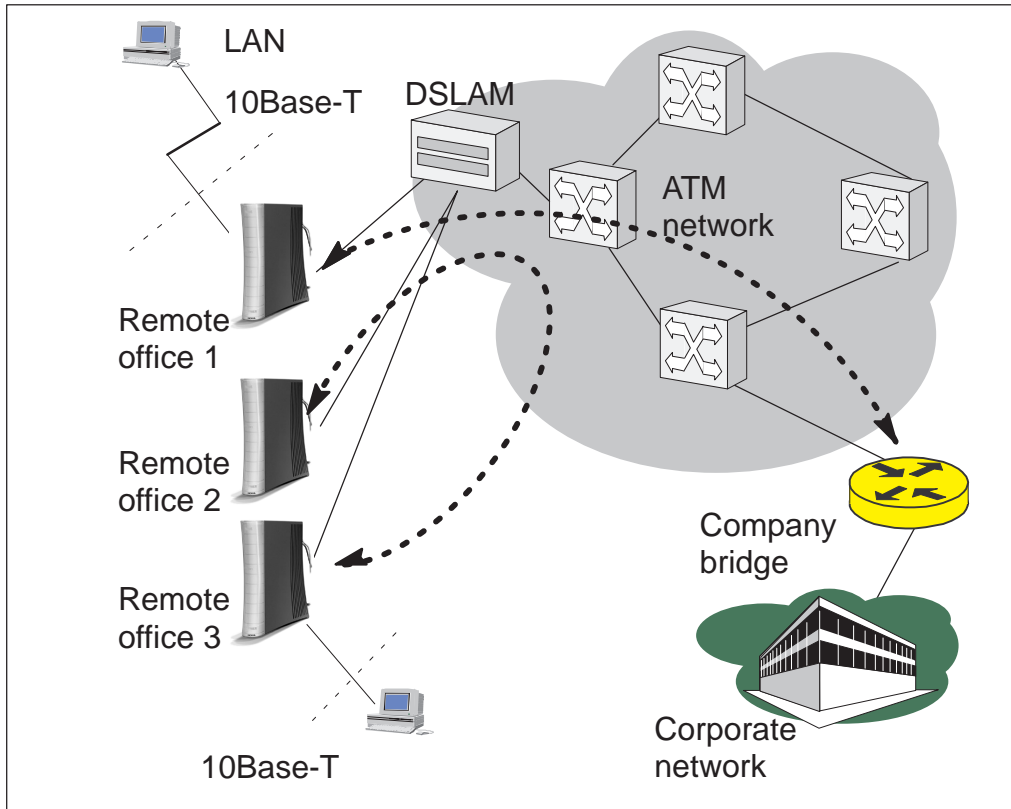

**Figure 2-3** LAN interconnection

## 2.2 Features

M1122 can operate as a bridge and/or Internet Protocol (IP) router between the Ethernet and the virtual channels of ADSL/ATM interfaces supporting both dynamic and static routing.

### 2.2.1 Interfaces

M1122 has the following interfaces:

- Four Ethernet interfaces (LAN)
- 8 ATM VCC interfaces
- ATM VCC management interface

- Gateway/bridge management interface. This interface is used as a bridge host interface or gateway interface depending on the operation mode. In this manual it is called VBRIDGE. On the M1122 web pages, the interface is called gateway or bridge IP interface.

M1122 can operate in four different main modes:

- Bridging only
- Routing/tunneling IP only
- Routing/tunneling IP, bridging all but IP
- Routing/tunneling IP and bridging all, including IP

The mode in which M1122 operates depends on the configuration of the unit's interfaces. Table 2-1 shows the operational modes and the corresponding interface configurations.

LAN interface	ATM VCC interfaces	Vbridge (gateway/host interface)
<b>Bridge only</b>		
Bridging	Bridging.	Used as a management (host) interface for all bridged interfaces in case such is needed.
<b>Route/tunnel IP only</b>		
Routing (IP address configured)	Routing (IP address configured) or PPTP local tunneling activated for each active ATM VCC.	Not used in this case. The unit can be managed through any of the LAN, or ATM interface IP addresses.



LAN interface	ATM VCC interfaces	Vbridge (gateway/host interface)
<b>Route/tunnel IP, bridge all other traffic</b>		
Routing (IP address configured) and bridging activated.	<p>VCCs that only route or tunnel have routing (IP address configured) or PPTP local tunneling activated.</p> <p>VCCs that both bridge and route have additionally bridging activated. This requires ETH-LLC encapsulation to be used on those VCCs.</p> <p>VCCs that only bridge have only bridging activated.</p>	Typically not used in this case. The unit can be managed locally through LAN interface and remotely through a separate management VCC or the ATM VCCs which have routing activated.
<b>Route/tunnel IP, bridge all other including IP</b>		
Bridging activated	<p>VCCs that only route or tunnel have routing (IP address configured) or PPTP local tunneling activated.</p> <p>VCCs that only bridge have only bridging activated.</p>	Used as an IP gateway interface for LAN interface.

**Table 2-1** Operational modes

**LAN interfaces**

LAN interfaces can be configured individually to bridge and route packets. There are three different operational modes in LAN interfaces:

- Bridging only; only bridging is activated in the interface. In this case the interface bridges all protocols.
- Routing only; only IP address is configured in the interface. In this case, the interface routes IP packets.
- Bridging and routing; Bridging is activated in the interface and IP address is configured in the interface. In this case, the interface routes IP packets and bridges all other packets.

## **Internal host/gateway interface**

There is a special host/gateway logical IP interface within M1122 called VBRIDGE. This interface has a specific purpose in M1122. In applications where some ATM virtual channel connections are used for bridging IP traffic and some other ATM virtual channel connections are used for routing IP traffic, the VBRIDGE interface must be used instead of LAN IP address. Alternatively, this interface is used in bridge only application when the IP address is required for remote management purposes.

## **Data VCC operation**

M1122 supports the following encapsulations in each ATM data virtual channel individually:

- RFC2684 LLC encapsulation for bridged IP (ETH-LLC)
- RFC2684 LLC encapsulation for routed IP (IP-LLC)
- RFC2364 Virtual circuit multiplexed PPP over AAL5 (PPP-VC)
- RFC2364 Virtual circuit multiplexed PPP over AAL5 used to tunnel LAN/VBRIDGE PPTP packets (TUNNELED-PPP-VC)

If an IP address is given to a virtual channel interface and bridging is enabled at that interface, then IP data at that interface is routed and all other protocols are bridged. The only encapsulation which allows both bridging and routing simultaneously is ETH-LLC. For example, it is possible to route ETH-LLC encapsulated packets and at the same time bridge, for example, PPPoE packets (PPPoE packets are transported directly over Ethernet frame, not within IP packets).

### **2.2.2 Routing**

Routing is based on routing entries in a routing table. Static routes are added via the management interface and dynamic routing is done using RIP and RIPv2. Routing is done between the Ethernet 10Base-T interface and the virtual channel connection (VCC) of the ATM/ADSL interface. M1122 supports up to 8 simultaneous VCCs.

M1122 supports IGMP (Internet Group Management Protocol) proxy receive function for IP multicast applications.

### **2.2.3 Bridging**

Bridging is supported to provide full protocol transparency. Bridging can be used simultaneously with IP routing. M1122 works as a self-learning bridge supporting up to 1024 MAC addresses. Bridging

is done between the Ethernet 10Base-T interface and each ATM VCC interface. Optionally, the bridging between the VCCs can be disabled.

### 2.2.4 Network Address Port Translation

M1122 supports Network Address Port Translation (NAPT) for TCP/IP, UDP/IP and ICMP/IP protocols. When NAPT is used, a single IP address is allocated to a VCC which leads to the public IP network. The Ethernet subnet has private IP addressing and is not visible to the VCC. NAPT translates the IP source address and source port number dynamically to the VCC IP address and port number. Similarly, packets coming from the VCC are mapped back to the original destination addresses. NAPT allows up to hundreds of hosts to share a single VCC IP address to the public network. The principle of Network Address Port Translation is presented in Figure 2-4.

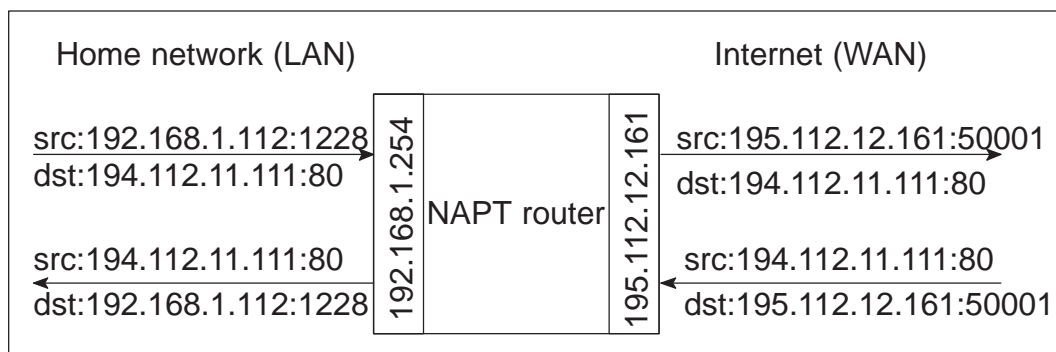

**Figure 2-4** Principle of Network Address Port Translation

NAPT may restrict the operation of some IP applications. NAPT also operates as a simple IP firewall because translation is only allowed when the first packet is transmitted from the LAN. This means that the NAPT table entry is created only when a packet is sent from the home network to the Internet. With server support capability, the user can add static entries to the NAPT table allowing the translation always in both directions. This capability is used to add servers (HTTP, NNTP, and FTP), which are visible to the public IP network via the VCC, on the LAN subnet.

NAPT supports most IP-based protocols. Because NAPT operates on the IP and transport layer, the application that includes IP address and port within the payload will not work properly through NAPT. In many cases, these applications can be passed through the NAPT using

Application Layer Gateway functionality (ALG). M1122 has ALG for the following protocols/applications:

- ICMP
- FTP
- H.323 including NetMeeting
- CUSeeMe
- PPTP
- IRC
- IPSEC ESP tunnel mode and IKE

Note, that most IPSEC implementations will fail when passed through NAT. A typical reason is that the identification may fail if the identification is based on IP address. Also, only tunnel mode without Authentication Header (AH) works.

### **2.2.5 Dynamic Host Configuration Protocol**

M1122 can act as a Dynamic Host Configuration Protocol (DHCP) server for the PCs on the end-user home network. In this mode, M1122 can assign up to 253+253 consecutive addresses from two separate address ranges (that is, 253 consecutive addresses per address range) to the PCs on the home network. Two separate address ranges can be used if more than 253 addresses are required on the local subnet, if two non-contiguous address ranges are needed or if an additional router with DHCP relay is used on the local network. M1122 can also act as a DHCP relay agent and relay the DHCP requests to an external DHCP server.

### **2.2.6 ATM and ADSL**

M1122 supports up to 8 simultaneous VCCs and supports UBR (Unspecified bit rate) traffic shaping on all VCCs. The maximum transmit rate on each VCC is the ADSL upstream capacity. If more than one VCC is transmitting simultaneously, the ADSL upstream capacity is temporarily shared between these VCCs. When one VCC is idle, the bandwidth is used by another VCC.

The ADSL transmission is based on the DMT line code. M1122 provides a DMT line rate up to 8 Mbit/s downstream and up to 800 kbit/s upstream. The DMT transceiver is rate adaptive and capable of providing faster rates over short distances or slower rates over long distances. The transceiver adapts itself to the line conditions. M1122

supports also ADSL Lite. In the ADSL Lite mode, the maximum line rates are 1536 kbit/s downstream and 512 kbit/s upstream.

M1122 supports both G.992.1 and G.992.2 ADSL recommendations defined by ITU-T.

Rate adaptation is done in steps of 32 kbit/s. The ADSL interface of M1122 functions completely automatically and all configuration related to the ADSL connection is done at the access multiplexer in the operator's premises. The network operator can set the data rates as a part of the network management functionality provided by Nokia DSLAM.

### 2.2.7 Point-to-Point Tunneling Protocol (PPTP)

When PPTP local tunneling is used, a local network client initialises a PPTP-tunneled PPP connection (VPN) to Nokia M1122. The modem terminates the tunnel and all data from that terminated local PPTP tunnel will be forwarded to an assigned ATM VCC by using PPP over AAL5 encapsulation. Thus, each local PPTP tunnel requires an equivalent ATM VCC assigned to it restricting the total number of local PPTP hosts to 8.

Local tunneling is used when there is a need to have one or more computers connected independently to different networks. For example, in remote work application, the rest of the family may be using the common ISP services and one or two family members need to gain access to their corporate networks. With local tunneling, these remote workers may be connected to a different network than the rest of the users.

Local tunneling is activated using the PPTP client running, for example, in Windows. The destination IP address must be M1122 LAN/VBRIDGE IP address depending on the configuration. PPP packets within PPTP are mapped to the configured VCC. M1122 has three different ways to choose the ATM VCC that will be used for tunneling:

- Automatic, chooses the first free VCC
- Chooses the VCC number using C:number, where number is from 1 to 8. C:number is typed after the M1122 IP address in PC's PPTP client Connect To window (see Figure 2-5).
- Chooses the VCC number using N:name, where name is the VCCx description. N:name is fed after the M1122 IP address.



**Figure 2-5** Choosing the VCC2 for tunneling example

### 2.2.8 Point-to-Point Protocol over Ethernet (PPPoE)

Standard PPPoE mode is used when M1122 is operating as a bridge. PPPoE protocol defines how PPP sessions are mapped into Ethernet packets. When M1122 operates as a bridge, this protocol is transparent to M1122.

### 2.2.9 Payload encapsulations

Both routed and bridged protocols are encapsulated in the ATM link by using either RFC 2684 LLC/SNAP encapsulation or VC multiplexing. M1122 also supports PPP over AAL5 encapsulation, in which routed protocols are first encapsulated in PPP (RFC 1661). PPP is then encapsulated in ATM according to the IETF PPP over AAL5 using RFC 2364 VC multiplexing or LLC/NLPID encapsulation.

### 2.2.10 Weighted Fair Queueing (Class of Service)

As a Class of Service (CoS) function, M1122 supports Weighted Fair Queueing (WFQ) for each ATM VCC. The CoS function ensures that different IP traffic flows are treated fairly in the upstream (towards the Internet) direction. This may be necessary, in some cases, because the upstream capacity of the ADSL line is somewhat limited compared to the Ethernet bandwidth on the office or home LAN. The WFQ CoS

function classifies IP traffic flows based on IP address, protocol and port fields. It is capable of identifying the IP flow from all supported payload encapsulation formats. WFQ works properly only with IP-based protocols. If the flow is IP-based but is encrypted using IPSec or PPP encryption, then WFQ cannot identify the flows correctly. In this case, the default flow is used and the default flow is treated as a single flow.

### 2.2.11 Management

There are three management methods in M1122:

- Command line interface (CLI) through console serial port
- CLI via telnet
- Web browser management

The CLI allows complete configuration of the unit; the Web browser management allows the configuration of the most frequently used configuration parameters.

### 2.2.12 Dedicated management channel

The operator or the Internet Service Provider can establish a dedicated management channel to M1122. This channel provides access to the M1122 management (with telnet or web browser) and it can be used to upload a new software to M1122.

The dedicated management channel is separated from the other IP stack. It is not possible to access the other interfaces or networks behind the data interfaces through the dedicated management channel. Similarly, access from LAN or data VCCs to the management channel is blocked. The management channel supports only routing using the following encapsulations:

- RFC2684 LLC encapsulation for bridged IP (ETH-LLC)
- RFC2684 LLC encapsulation for routed IP (IP-LLC)
- RFC2364 Virtual circuit multiplexed PPP over AAL5 (PPP-VC)

In Figure, 2-6 VCC1 is used for customers data transmission. Administration through this channel has been disabled. The operator or the service provider uses the management VCC for management purposes only.



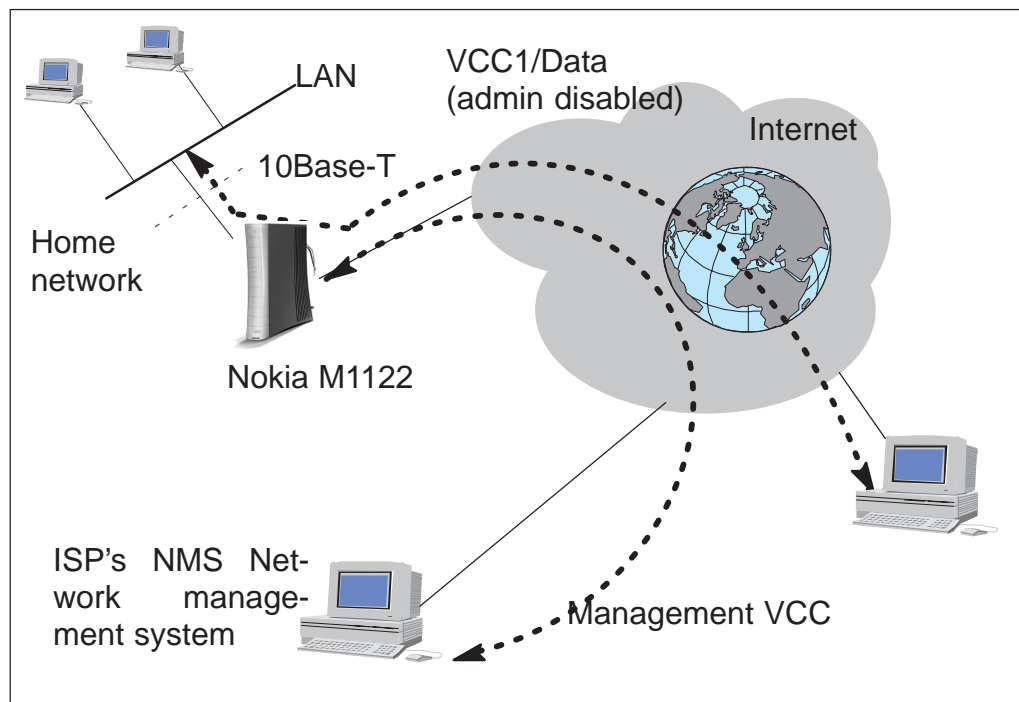

**Figure 2-6** Dedicated management channel





## Chapter 3

# Interfaces and indicator lights

This chapter describes the external interfaces of M1122 and introduces its front panel indicator lights.

### 3.1 Interfaces

M1122 has one ADSL line interface and four LAN interfaces (10Base-T Ethernet). It also has a local management interface (CLI) for management purposes. The ADSL line interface is compatible with ITU-T G.992.1 specification.

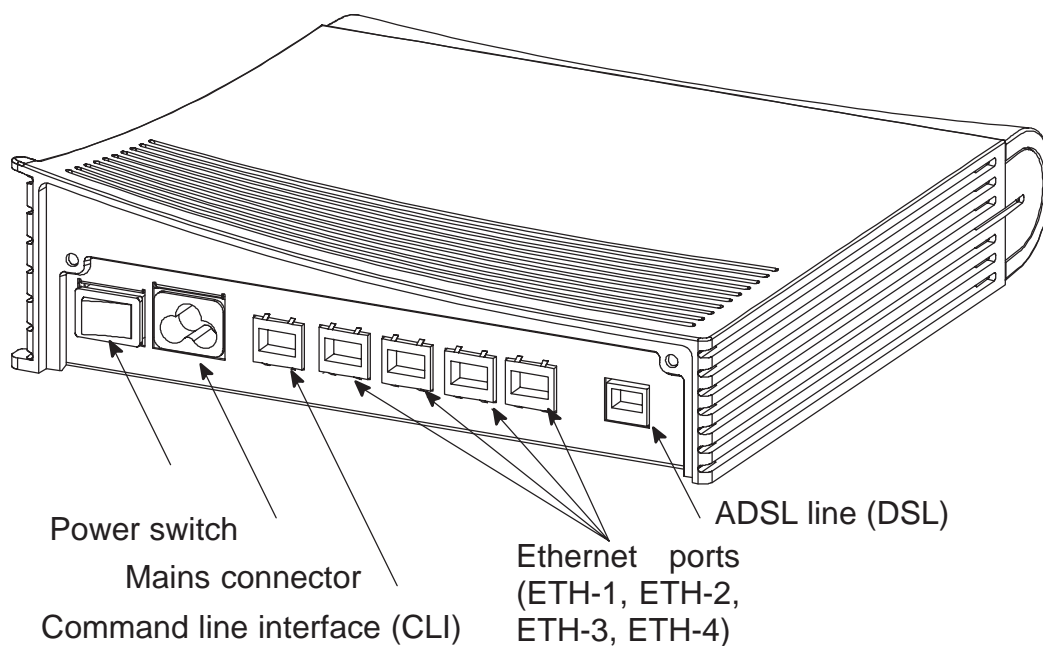

**Figure 3-1** M1122 back panel

## 3.1.1 Ethernet interface

The Ethernet interfaces (ETH) are located on the back panel. The Ethernet interface is a standard 10 Mbit/s half-duplex 10Base-T interface. The mechanical connector is an 8-pin RJ-45. The pin-out numbering is shown in Table 3-1.

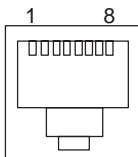

**Figure 3-2** ETH connector

PIN	Signal	Direction M1122- Ethernet	MDI signal
1	Rx+	<-	Receive data +
2	Rx-	<-	Receive data -
3	Tx+	->	Transmit data +
6	Tx-	->	Transmit data -

**Table 3-1** Ethernet interface pin-out numbering

## 3.1.2 ADSL interface

The ADSL interface (DSL) is compatible with ITU-T G.992.1 specification. The mechanical connector is a 6-pin RJ-11. The pin-out numbering is shown in Table 3-2.

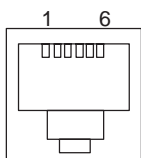

**Figure 3-3** DSL connector

PIN	Signal
3	DSL1
4	DSL2

**Table 3-2** ADSL interface pin-out numbering

### 3.2 Command line interface

The command line interface (CLI) is RS-232 interface with an RJ-45 mechanical connector. The pin-out numbering is shown in Table 3-3.

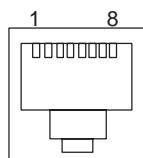

**Figure 3-4** CLI connector

PIN	Signal	Direction M5112-ter- minal	MDI signal
1	107 DSR (const. ON)	→	Data set ready
2	108 DTR	←	Data terminal ready
3	109 DCD (const. ON)	→	Data channel re- ceived line signal de- tector
4	102 SG		Signal ground
5	103 TxD	←	Transmitted data
6	104 RxD	→	Received data
7	105 RTS (not in use)	←	Request to send
8	106 CTS (const. ON)	→	Clear to send

**Table 3-3** Command line interface pin-out numbering

## 3.3 Indicator lights

M1122 has eight indicator lights on the front panel: PWR, STA, COL, ETH-1, ETH-2, ETH-3, ETH-4, and DSL. STA indicator is red. Other indicators are green.

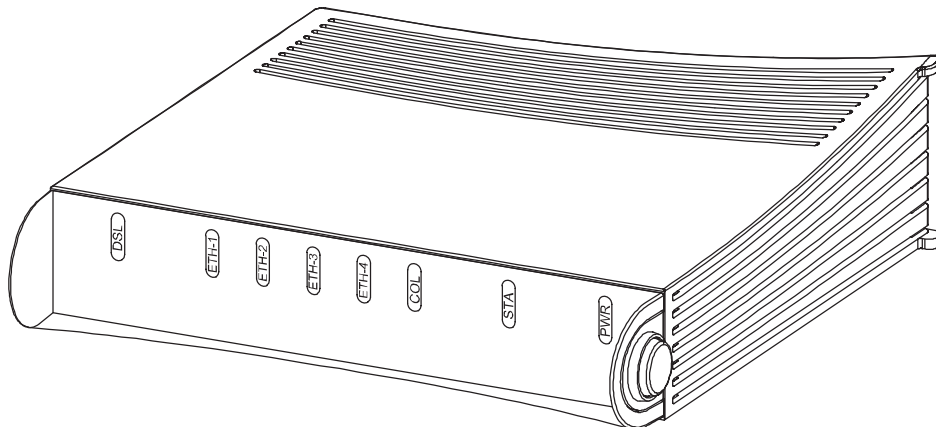

**Figure 3-5** M1122 front panel indicators

**DSL** GREEN

Off ADSL link is down.

Blinks ADSL connection is being established.

On ADSL link is up.

**ETH-** GREEN

Off Ethernet is down.

On 10Base-T Ethernet is functional

Blinks Receives traffic from Ethernet.

**COL** GREEN

Blinks Collisions on the Ethernet. Note, that it is normal that some collisions occur on the Ethernet.

**STA** RED

Off OK  
On Hardware malfunction during startup.

**PWR** GREEN

Off Power off.  
On Power on.

---



## **Chapter 4**

# **Installing Nokia M1122**

This chapter presents a step-by-step installation procedure of M1122. Before starting the installation check that M1122 is physically undamaged. The package contains the following items:

- M1122 modem
- ADSL line cable
- Straight 10Base-T Ethernet cable
- power cord
- serial adapter
- User Manual

### **4.1 M1122 default settings**

Typically, M1122 has a customer-specific configuration. The default configuration of a general version is shown in Table 4-1.



<b>Config mode level</b>	<b>Parameter</b>	<b>Setting</b>
system	hostname	<b>M1122</b>
eth	IP address	<b>192.168.1.1</b> <b>255.255.255.0</b>
vcc1	pvc	<b>0</b> (vpi) <b>100</b> (vci) <b>ppp-vc</b> (encaps)
	IP address	<b>0.0.0.0 0.0.0.0</b> , means that M1122 gets its IP address dynamically from the network.
	IP NAPT	<b>on</b>
	ppp authentication	<b>both-chap-pap</b>
	ppp username	<b>none</b>
	ppp password	<b>none</b>
common	ip route	<b>0.0.0.0 0.0.0.0 0.0.0.0</b> <b>vcc1</b>
	DHCP mode	<b>server</b>

**Table 4-1** M1122 default settings

## 4.2 Step-by-step installation procedure

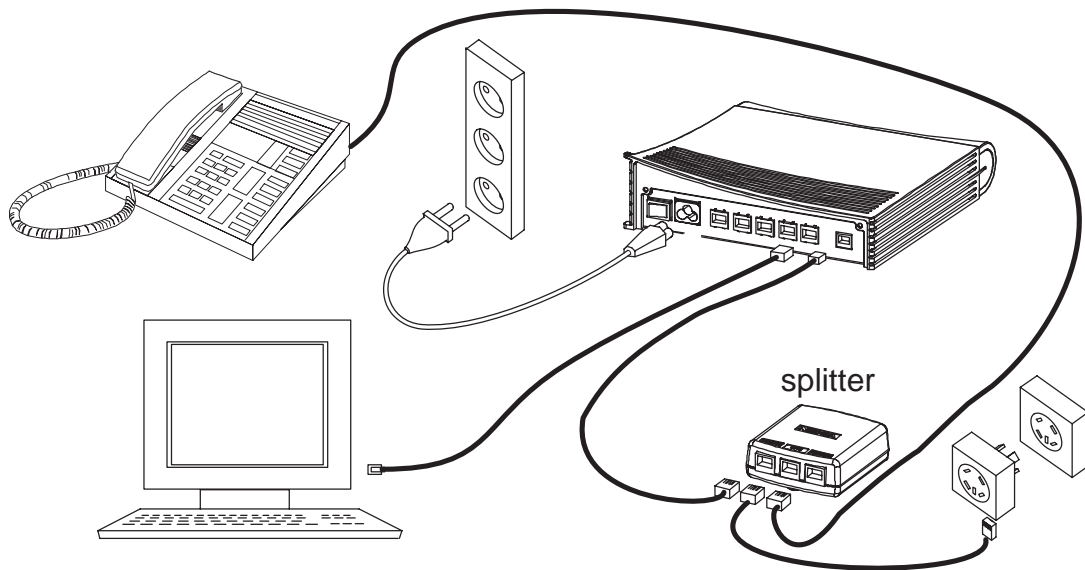

**Figure 4-1** M1122 with cables and splitter (T66270) connected (Telephone and ADSL services)

1. Plug the mains power cord to a mains outlet.
2. Switch on M1122. The PWR indicator lights up. After a while, the red STA indicator blinks and then remains unlit. M1122 is now functional.
3. Connect the Ethernet cable between your PC's 10Base-T connector and the Ethernet connector on the M1122 back panel (ETH-1, ETH-2, ETH-3, or ETH-4).
4. Switch on your PC. The indicator corresponding the Ethernet port you connected your PC to becomes green when your PC has started. This indicator blinks when there is traffic in the corresponding Ethernet port.
5. Connect the ADSL line cable between the DSL connector on the M1122 back panel and ADSL line wall socket. If you want to use ADSL and telephone services simultaneously, connect the splitter according to Figure 4-1. After a while, the DSL indicator starts blinking. This indicates that the ADSL line is being established. When the DSL indicator remains lit, the line is functional.
6. During normal operation PWR and DSL indicators are lit and the Ethernet indicators of the active Ethernet ports blink or are lit depending whether there is traffic or not. COL indicator may blink occasionally during normal operation.

Now, your M1122 has been connected and you can check the connections according to your service provider's instructions.

---

## **Chapter 5**

# **Managing M1122**

This chapter shows some operational examples of M1122. The examples can be used as a guide when you are planning your configuration. After the operational examples, we introduce the management methods of M1122. First we show how to use the web browser management and then the command line interface (CLI) will be presented. The command line interface section contains all CLI commands.

### **5.1 Operational examples**

This section presents some typical operational examples and the corresponding configurations. Figure 5-1 shows a general block diagram of the IP forwarding and bridging functions of M1122.

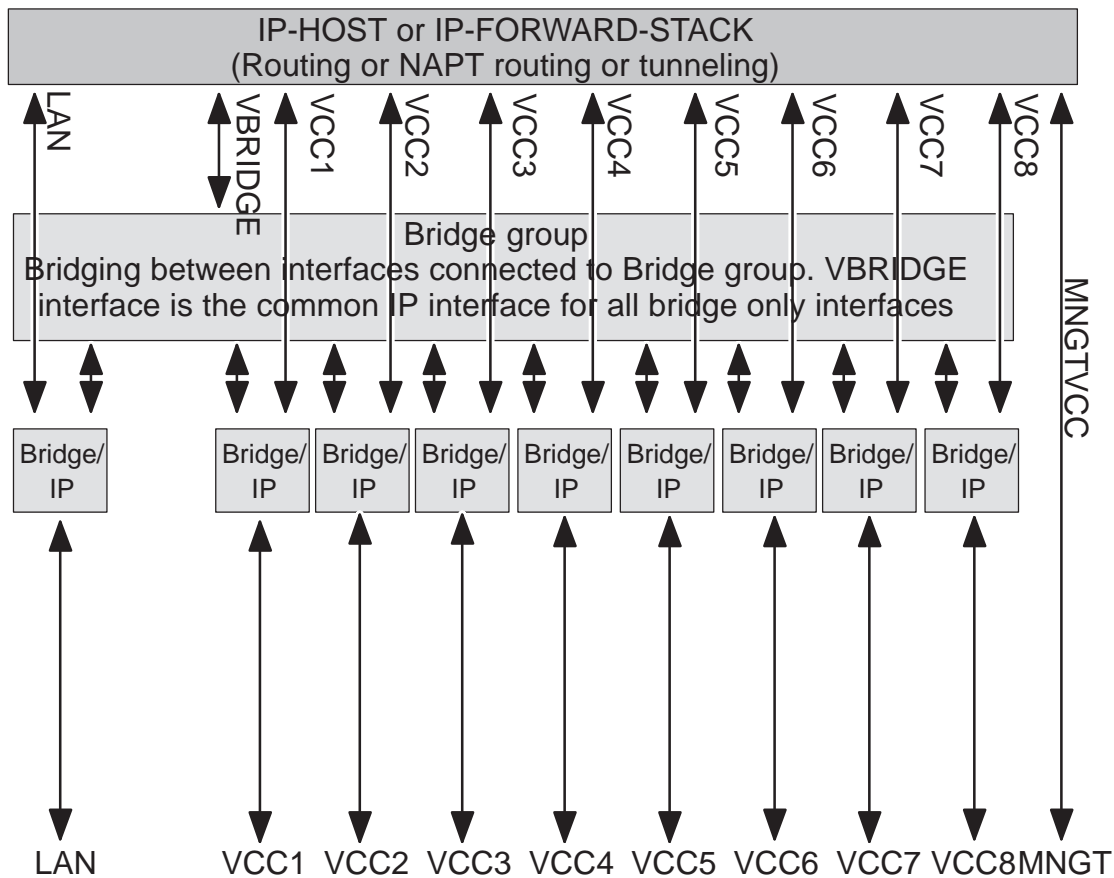

**Figure 5-1** Block diagram

### 5.1.1 Routing/tunneling IP only

If the application requires only routing of IP packets, an IP address should be configured for each interface in use. The example below shows a typical configuration in such a case.

```
M1122> show conf running
eth
  ip address 192.168.1.1 255.255.255.0
vcc1
  pvc 0 101 ip-llc
  ip address 10.98.16.1 255.255.255.0
M1122>
```

### 5.1.2 Routing/tunneling IP, bridging other protocols

When the application requires routing IP packets and bridging all other protocols, then IP address has to be configured and bridging enabled

for all relevant interfaces. The result is that IP packets will be routed and all other packets will be bridged. In the configuration example below, LAN interface routes IP traffic and bridges all other protocols. ATM VCC1 routes IP traffic and ATM VCC2 interfaces bridges all traffic.

```
M1122> show config running
eth
    ip address 192.168.1.1 255.255.255.0
    bridging
vcc1
    pvc 0 101 ip-llc
    ip address 10.98.16.1 255.255.255.0
vcc2
    pvc 0 102 eth-llc
bridging
M1122>
```

### **5.1.3 Routing/tunneling IP, bridging all protocols including IP**

When IP packets that are received from LAN must be routed/tunneled to some ATM VCC and bridged to some other ATM VCC, then the VBRIDGE interface must be used as this common IP interface for all bridged interfaces. LAN interface is in this case configured as bridge only.

```
M1122> show config running
eth
    bridging
vcc1
    pvc 0 101 ip-llc
    ip address 10.98.16.1 255.255.255.0
vcc2
    pvc 0 102 tunneled-ppp-vc
vcc3
    pvc 0 103 eth-llc
    bridging
vbridge
    ip address 192.168.1.1 255.255.255.0
M1122>
```

### 5.1.4 Bridging only

When only bridging is required, all ATM VCCs are configured as bridge. VBRIDGE IP address can be used as an optional management interface.

```
M1122> show config running
eth
  bridging
vcc1
  pvc 0 101 eth-llc
  bridging
vcc2
  pvc 0 102 eth-llc
  bridging
vbridge
  ip address 192.168.1.1 255.255.255.0
M1122>
```

## 5.2 Typical configuration tasks

This section provides some typical configuration tasks. These configuration examples can be done through the command line interface.

---

### Note

After you have made changes to the configuration, you must save the configuration if you want it to be active also after restarting M1122.

---

### 5.2.1 Configuring DHCP and DNS

The DHCP server can be enabled towards LAN and VBRIDGE ports. When the DHCP server is enabled, up to two address ranges (scopes) will be automatically generated and bound to LAN/VBRIDGE interfaces, in this order if the interface has an IP address. Two address ranges can be used if more than 253 addresses are required on the local subnet, if two non-contiguous ranges are needed or if an additional router with DHCP relay is used on the local network.

The address range defines pool of IP addresses and parameters like default gateway, DNS addresses and domain name. The generated default address range allows up to 253 IP addresses (C class).

Automatically generated address ranges use LAN/VBRIDGE IP address as gateway and DNS server addresses. If one address range is defined, then automatic binding will be disabled. If optional address range parameters like gateway or DNS addresses are not defined, LAN/VBRIDGE IP addresses are used as in automatic binding.

Typically, when DHCP is used, the advertised DNS addresses point to LAN/VBRIDGE interfaces. In such cases, the DNS proxy forwards the DNS request to statically configured DNS servers or to DNS servers learned dynamically via PPP/PCP.

The following commands are used to configure DHCP and DNS settings:

```
M1122 (conf-common) #dhcp?
usage: dhcp mode
       dhcp address
       dhcp gateway
       dhcp dns
       dhcp lease-time
       dhcp domain-name
M1122 (conf-common) #dhcp mode server ; this enables
DHCP server
```

Normally, there is no need to configure the DNS addresses. If the service provider does not support automatic DNS address allocation, the DNS servers can be configured as shown by the following example:

```
M1122 (conf-common) # dns address primary 1.2.3.4
M1122 (conf-common) # dns address secondary 1.2.3.5
M1122 (conf-common) #
```

## **5.2.2 Configuring static and dynamic routing**

Routing entries in the routing table are needed in order to forward the IP packets to the correct interface. M1122 has both static and dynamic routes. Static routes are configured manually and dynamic routes are learned automatically using RIP v1 and RIP v2 protocols. The following examples show how to configure static routes to M1122.

Default gateway for an interface that learns the next hop automatically:

```
M1122 (conf-common) # ip route 0.0.0.0 0.0.0.0 0.0.0.0
vcc1
```



Default gateway for an interface that requires static next hop:

```
M1122(conf-common)# ip route 0.0.0.0 0.0.0.0 1.2.3.1
vcc1
```

Static route for an interface that learns the next hop automatically:

```
M1122(conf-common)# ip route 131.132.133.0
255.255.255.0 0.0.0.0 vcc1
```

Static route for an interface that requires a static next hop:

```
M1122(conf-common)# ip route 131.132.133.0
255.255.255.0 1.3.5.1 vcc1
```

M1122 can have only one default gateway. The interfaces that can learn gateway/peer address dynamically can use value 0.0.0.0 instead of the next hop address.

### 5.2.3 File system and downloading new firmware using TFTP

M1122 has a flash file system. Some files in the file system have special meanings. These files are:

- image.exe; primary application file.
- image.bak; secondary application file used if image.exe has been corrupted or is missing. It is then renamed as image.exe automatically.
- startup.cfg; primary configuration file used during startup.
- dhcp.leases; contains DHCP lease table information.

M1122 has the following commands that can be used for file handling:

- copy
- rename
- delete
- dir

If you use image.exe as a destination filename with the copy command and the image.exe already exists, the existing image.exe will be automatically renamed as image.bak. This guarantees that the application file exists if M1122 loses power during SW download.

You can update the operating software of M1122 by downloading the new software from a TFTP server. To download and activate new M1122 operating software:

1. Use CLI to issue  
`install tftp://<ip-address>/Gx1x2200.R00` command, where `<ip-address>` is the IP address of the TFTP server containing the new software and `Gx1x2200.R00` is the name of the file to be downloaded. The command `copy tftp://<ip-address>/Gx1x2200.R00 image.exe` can be used alternatively.
2. After you will see `transfer status SUCCESSFUL` message, restart M1122 to activate the new software.

## Downloading configuration or application from monitor

Monitor is a small application that is executed before the actual software image is started. Typically the Monitor automatically loads the application file `image.exe`. You can activate the Monitor by pressing “m” followed by “o” in the very beginning of the system startup:

```
local MAC=00:40:43:02:36:72; Using M111/850 eth conf
Type 'm' (fast) followed by 'o' (in 10 sec) to
activate Monitor
Nokia Networks (C) 1999
Nokia Boot
B-R0.0.0. built on Apr 4 2000 11:27:55
MON>
```

The following commands are available for file handling in the Monitor:

- `rename`
- `delete`
- `dir`

M1122 has two methods of retrieving files:

- TFTP
- XMODEM

You can retrieve files from a TFTP server using the commands in the following example:

```
MON>ipa 192.168.1.1
    ip=192.168.1.1
ipserver=0.0.0.0
    ipgw=0.0.0.0
serverfile=
MON>ips 192.168.1.100
```

```
    ip=192.168.1.1
ipserver=192.168.1.100
    ipgw=0.0.0.0
serverfile=
MON>file startup.cfg
    ip=192.168.1.1
ipserver=192.168.1.100
    ipgw=0.0.0.0
serverfile=startup.cfg
MON>eget
tftp loader
    ip=192.168.1.1
ipserver=192.168.1.100
    ipgw=0.0.0.0
serverfile=startup.cfg
loading file...
file size=556
MON>wri startup.cfg
Writing successful
MON>
```

A file can also be transmitted from an XMODEM1K running in a PC, for example, as in the following example:

```
MON>xget
Start Xmodem1k sending...
MON>wri image.exe
Writing successful
MON>
```

### 5.3 Browser management

M1122 can be managed with a web browser or command line interface (CLI). The web configuration pages of M1122 can be accessed through the Ethernet ports or through the ADSL/ATM channels of M1122. In order to access the web management feature, the IP functionality must be activated and an IP address must be given to the corresponding interface.

You can use your PC's web browser software to access the web configuration pages in M1122. To access the web pages you must know the IP address of your M1122 or, alternatively, the "name" that your M1122 recognises.

---

## Note

Before using your web browser for configuration, you must know the IP address or the name assigned to your M1122.

---

There are three ways to find out whether to use a name or an IP address:

- Your service provider has given you an IP address for M1122.
- Your M1122 uses Dynamic Host Configuration Protocol (DHCP) and Domain Name Server. In this case the name is *M1122*.
- Your M1122 uses DHCP. In this case run winipcfg.exe (Windows 95) or ipconfig.exe (Windows NT). The IP address of M1122 is the Default Gateway address shown by the ipconfig program.

### 5.3.1 Opening a connection

To open a connection to the Nokia M1122:

1. Start your web browser.
2. Enter the name ('M1122') or IP address of your Nokia M1122 in the browser's Open Location field and press Enter. If you use the IP address, it has to be assigned to a local port or gateway interface (VBRIDGE).
3. Type in the username/password as requested. If no username/password is required, just click OK to proceed. The Nokia M1122 Main Page appears.

## 5.3.2 Main Page

Main Page is shown first when you use a web browser to connect to M1122. The currently shown page is shown highlighted on the list on the left. Clicking an item on the list (Service Providers, Local Network, Statistics, Restart, and Save Config) takes you to the corresponding page.

---

### Note

When you make modifications to the configuration, remember to save the configuration and restart your M1122 for your changes to take effect.

---

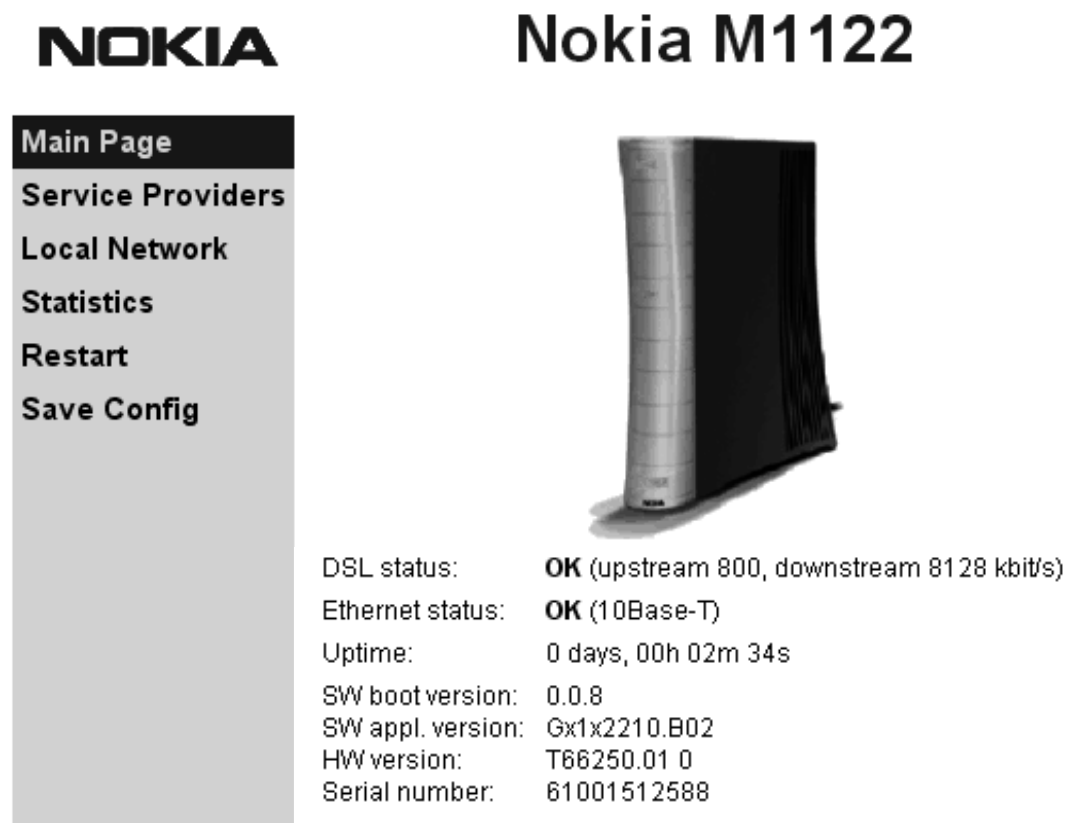
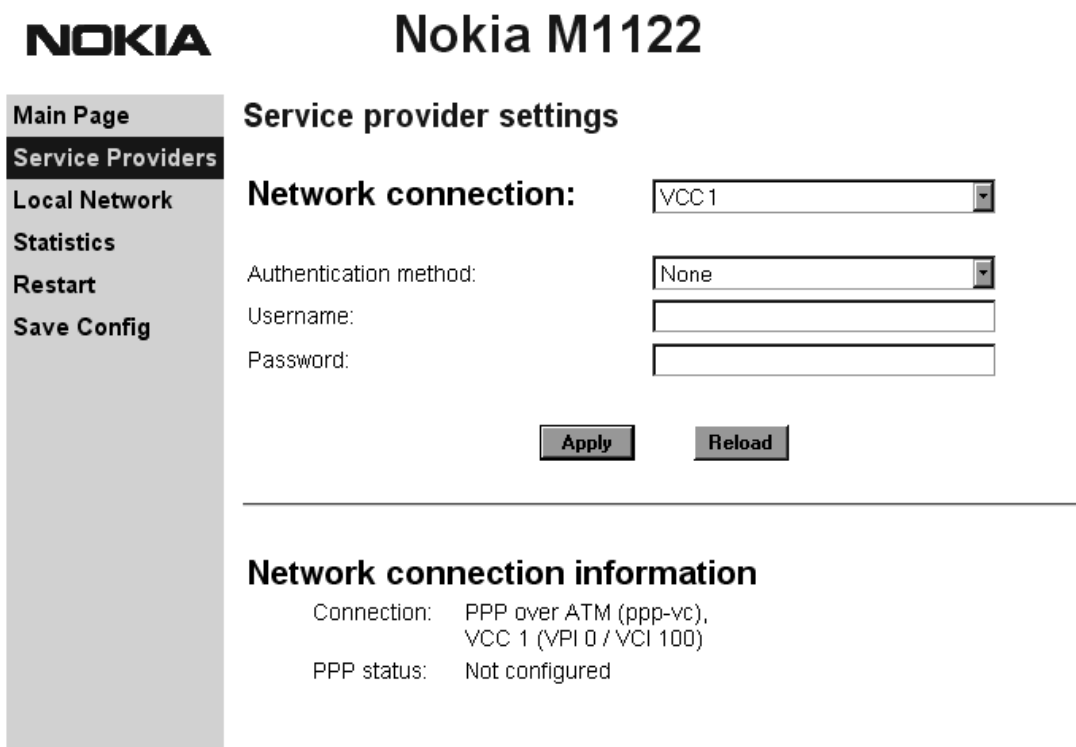

**Figure 5-2** Main Page

The Main Page shows you the statuses of the DSL line and Ethernet interfaces. Software and hardware versions and the serial number of M1122 are shown in the bottom of the page.

### 5.3.3 Service Providers pages

The *Service Providers* page can be used to set authentication for ATM VCCs with PPP encapsulation (Figure 5-3). You can set the *Authentication method* and the corresponding *Username* and *Password*. You can also view Network connection information in the bottom of the page. If you are using PPTP encapsulation, you can change the name of the connection through the Service Providers page (Figure 5-4). The name can be used in your PPTP client for tunnel configuration, see section 2.2.7 *Point-to-Point Tunneling Protocol*.



**Figure 5-3** Service Provider page with PPP configuration

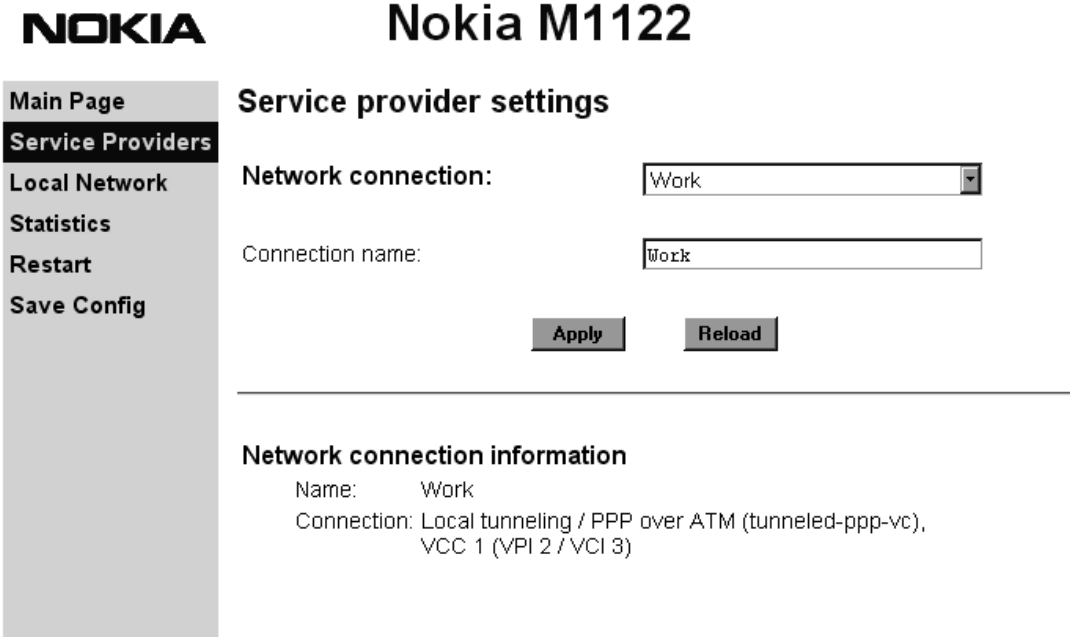

Figure 5-4 Service Providers page with PPTP configuration

## 5.3.4 Local Network pages

The *Local Network* page as four sub pages: *Local ports*, *DHCP*, *NAPT*, and *Routing*.

### Local ports

On the *Local Network Local Ports* sub page you can assign an IP address to Ethernet port.

---

#### Note

When you click Apply, the IP addresses are changed immediately. If the IP address of the interface you are using changes the connection will be lost. You have to reconfigure the IP address of the accessing host. For example, in Windows programs winipcfg.exe or ipconfig.exe must be used first to release the old address and then to renew to request new address.

---

The screenshot shows the Nokia M1122 web interface. At the top left is the 'NOKIA' logo. The main title is 'Nokia M1122'. Below the title is a navigation bar with four tabs: 'Local Ports' (selected), 'DHCP', 'NAPT', and 'Routing'. On the left side, there is a vertical menu with the following items: 'Main Page', 'Service Providers', 'Local Network' (highlighted), 'Statistics', 'Restart', and 'Save Config'. The main content area is titled 'Local network port settings'. Underneath, it says 'LAN port IP addresses:'. There are two input fields: 'Gateway port' with the value '192.168.172.1' and 'Net mask' with the value '255.255.255.0'. Below these fields are two buttons: 'Apply' and 'Reload'.

**Figure 5-5** Local Network Local Ports page

### DHCP

On the *Local Network DHCP* subpage you can enable/disable Dynamic Host Control Protocol and set the Address ranges from which the addresses are distributed to the DHCP clients on your network. You can also set the Domain Name Server addresses here.



*Start address* is the first address in the address range. The *Range size* defines how many addresses the range contains. *Subnet mask* is the subnet mask of the addresses in the range. *Primary* and *Secondary DNSs* set the domain name servers for the corresponding address range. *Lease time* defines how often the DHCP client must renew its lease. *Domain name* defines the domain name for the range.

The DHCP server can be enabled towards LAN and VBRIDGE (gateway interface) ports. When the DHCP server is enabled, up to two scopes (address ranges) are automatically generated and bound to LAN/VBRIDGE interfaces, in this order if the interface has an IP address. In Figure 5-6, scope (a) has been bound to Ethernet interface and scope (b) to VBRIDGE interface. When the address ranges are not defined, M1122 uses the default values for all DHCP parameters. The default values are:

- Start address is the interface IP address
- Subnet mask 255.255.255.0
- Range size of up to 253 addresses starting from the interface IP address.
- DNS address is the interface IP address
- Lease time is 60 minutes
- Domain name is null string

If at least one address range has been defined, then IP address, DNS, domain name and lease time, if defined, override the default values.

<b>Main Page</b> <b>Service Providers</b> <b>Local Network</b> <b>Statistics</b> <b>Restart</b> <b>Save Config</b>	Local Ports	DHCP	NAPT	Routing
	<b>Local network DHCP settings</b>			
	Local DHCP server		On	
	<b>Address range 1</b>			
	Start address	<input type="text"/>	Subnet mask	<input type="text"/>
			Range size	<input type="text"/>
Primary DNS	<input type="text"/>	Secondary DNS	<input type="text"/>	
Lease time (minutes)	<input type="text"/>	Domain name	<input type="text"/>	
<b>Address range 2</b>				
Start address	<input type="text"/>	Subnet mask	<input type="text"/>	
		Range size	<input type="text"/>	
Primary DNS	<input type="text"/>	Secondary DNS	<input type="text"/>	
Lease time (minutes)	<input type="text"/>	Domain name	<input type="text"/>	
<b>Apply</b>		<b>Reload</b>		

**DHCP server status**

```

## scope (a)      pool-address  pool-last   pool-mask
                  192.168.173.1 192.168.173.254 255.255.255.0
                  net-binding  primary-dns secondary-dns
                  ETH          192.168.173.1 n/a
                  lease-time   gateway     domain-name
                  00/01:00:00  192.168.173.1 n/a
## scope (b)      pool-address  pool-last   pool-mask
                  192.168.172.1 192.168.172.254 255.255.255.0
                  net-binding  primary-dns secondary-dns
                  VBRIDGE     192.168.172.1 n/a
                  lease-time   gateway     domain-name
                  00/01:00:00  192.168.172.1 n/a
    
```

**Figure 5-6** Local Network DHCP page

## NAPT

If Network Address Port Translation (NAPT) has been activated, servers on your local network are not visible outside your network. On NAPT page, you can configure pinholes through which you can provide outside access to your web server from the Internet, for example.

In the example shown in Figure 5-7, a pinhole has been added on the Server list. This example means that all TCP traffic coming from the Internet through VCC1 to ports 80...89 will be mapped to the IP address 192.168.1.15 ports 90...99 on your local network.

**NOKIA** **Nokia M1122**

Main Page Local Ports DHCP **NAPT** Routing

Service Providers

**Local Network**

Statistics

Restart

Save Config

### Local network NAPT settings

Network connection:

#### Server list (pinholes)

Entry name	Address (internal)	Start port (internal)	Start port (external)
<input type="text"/>	<input type="text"/>	<input type="text"/>	<input type="text"/>
Number of ports	<input type="text"/>	Protocol	<input type="text" value="TCP"/>
<input type="text"/>	<input type="text" value="192.168.1.15"/>	<input type="text" value="90"/>	<input type="text" value="80"/>
Number of ports	<input type="text" value="10"/>	Protocol	<input type="text" value="TCP"/>

**Figure 5-7** Local Network NAPT page

**Routing page**

On the *Local Network Routing* sub page you can set static routes and enable/disable dynamic routing protocols (Routing Information Protocol version 1 and 2).

To enable dynamic routing to a particular interface select the Routing protocol version from the pull-down list and click the Apply button. RIP versions 1 and 2 are supported. Send *v1-compat. v2* option enables the sending of RIPv2 packets using broadcast. Receive *v1-compat. v2* option enables the receiving of both RIPv1 and RIPv2 packets.

To add a static route, type in the *Destination network* IP address, the *Subnet mask* of the destination network, and the *Gateway* and the *Interface* through which the destination network can be reached. Then click the *Add new* button. There are two static routes in Figure 5-8.

**NOKIA** **Nokia M1122**

Main Page | Local Ports | DHCP | NAPT | **Routing**

Service Providers

**Local Network**

Statistics

Restart

Save Config

---

**Routing settings**

**Dynamic routing protocols**

Gateway:      Send       Receive

---

**Static routes**

Destination network	Subnet mask	Gateway	Interface	
<input type="text"/>	<input type="text"/>	<input type="text"/>	<input type="text" value="Eth."/>	<input type="button" value="Add new"/>
<input type="text" value="192.168.5.0"/>	<input type="text" value="255.255.255.0"/>	<input type="text" value="192.168.172.10"/>	<input type="text" value="Eth."/>	<input type="button" value="Remove"/>
<input type="text" value="0.0.0.0"/>	<input type="text" value="0.0.0.0"/>	<input type="text" value="0.0.0.0"/>	<input type="text" value="VCC"/>	<input type="button" value="Remove"/>

**Figure 5-8** Local Network Routing page

5.3.5 Statistics page

The Statistics page lets you view a selection of M1122 statistics. to view statistics of a particular function, click the corresponding button and the statistics view is opened on a separate window.

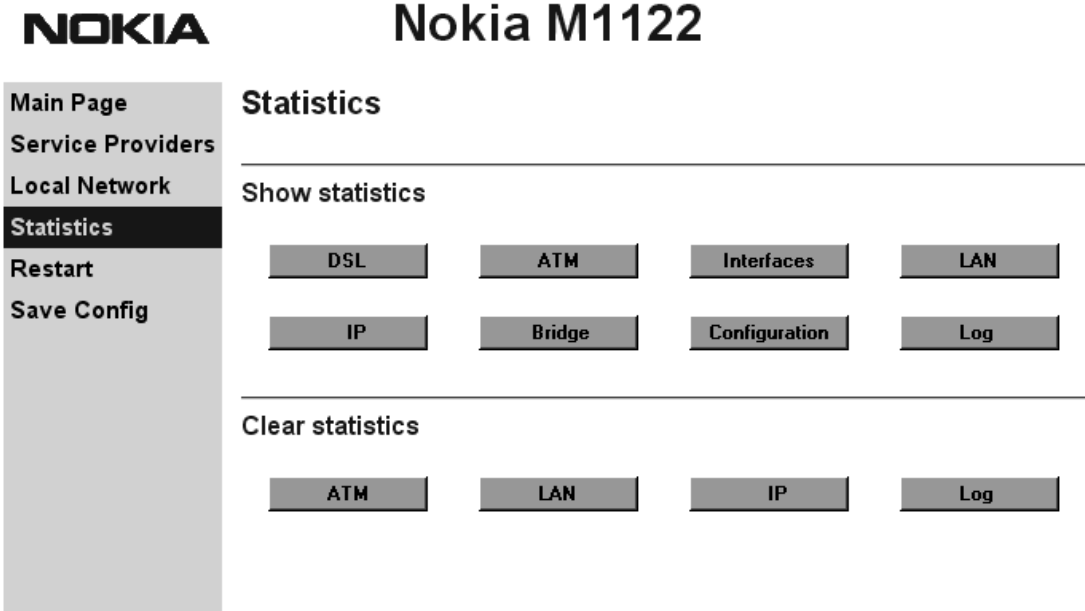

Figure 5-9 Statistics page

## 5.3.6 Restart page

On the Restart page, you can reset subsystems and restart M1122.

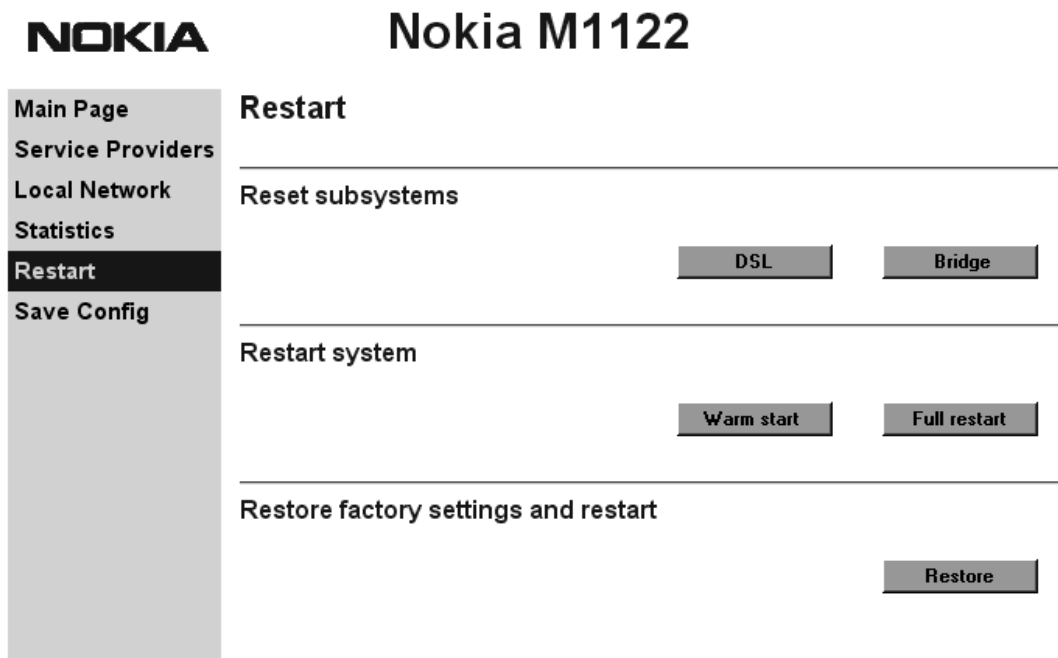

Figure 5-10 Restart page

## 5.3.7 Save Config page

When you change the configuration, all configuration changes are activated immediately without restart/reload. However, the configuration will not be saved into the nonvolatile memory. If M1122 is restarted or powered down without saving the configuration, the old configuration will be restored. Clicking the Save configuration button saves the configuration into the nonvolatile memory and the old configuration cannot be restored through the web interface.

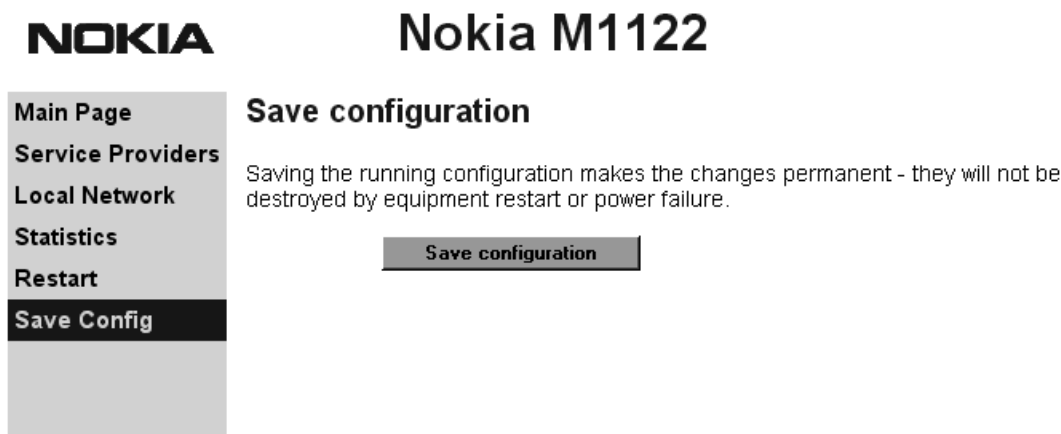

Figure 5-11 Save Config page

## 5.4 Command line interface (CLI)

M1122 can be managed locally through a command line interface (CLI). The local command line interface is accessed through the local management console on the back panel. The local management console interface is an asynchronous V.24/V.28 character-based interface with the following configuration:

Setting	Value
Speed	9600
Parity	None
Data bits	8
Stop bits	1
Duplex	Full
Flow control	None

**Table 5-1** Local management console configuration

Use the 10Base-T Ethernet cable with the serial adapter to connect you PC's serial port to the local management console interface according to Figure 5-12.

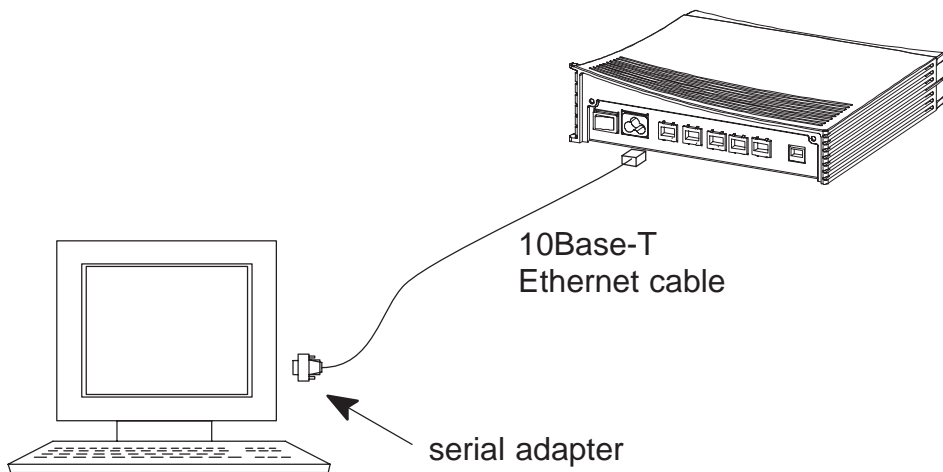

**Figure 5-12** Local management cabling

The command line interface can also be accessed through the Ethernet port of M1122 or through the ATM channels of M1122 on top of the telnet protocol. In order to use the CLI through telnet or the ATM channel, the IP function must be switched on and IP address must be given to the corresponding interface.

M1122 can also be managed remotely through a separate ATM virtual channel. This channel is only used for management purposes. In order to use this management channel, it has to be activated first and given an IP address configuration. The management traffic to this interface is not routed to any other interfaces of M1122.



The command line interface has been divided into two modes: main and configuration. The main mode lets you monitor the status and performance of M1122. The configuration mode lets you change M1122 configuration. The CLI is case sensitive. All commands must be given in lower case characters. Only file names and strings can contain upper case characters.

In the configuration mode, functions can be activated by typing the corresponding command, for example `bridging`. The function can be deactivated by simply typing `no bridging`. In commands which require typing in parameter values, the default value can be restored by typing `de ppp mru`, for example. `de` in front of the command means “default”. If you type in a value which is incorrect (for example, letters instead of numbers), the CLI prompts you to enter the value correctly and displays help. You can always get help on the command or display by typing `help` or `?` at the command prompt.

You can recall your previous commands by pressing the “up-arrow” key on your keyboard.

The configuration mode has been divided into levels. You can navigate through the configuration mode by typing the name of the level. By typing `exit` you will return to the main mode. `top` command returns you to the root level of the configuration mode (`M1122 (conf) #`).

The configuration mode levels are:

- system
- password
- eth
- vcc1, vcc2, vcc3, vcc4, vcc5, vcc6, vcc7, and vcc8
- vbridge
- mngtvcc
- common.

The example below shows how to access the different levels:

```
M1122>
M1122>conf
M1122 (conf) #system
M1122 (conf-system) #password
M1122 (conf-password) #eth
M1122 (conf-eth) #vcc1
M1122 (conf-vcc1) #vcc2
M1122 (conf-vcc2) #vcc3
M1122 (conf-vcc3) #vcc4
```

```
M1122 (conf-vcc4) #vcc5
M1122 (conf-vcc5) #vcc6
M1122 (conf-vcc6) #vcc7
M1122 (conf-vcc7) #vcc8
M1122 (conf-vcc8) #vbridge
M1122 (conf-vbridge) #mngtvcc
M1122 (conf-mngtvcc) #common
M1122 (conf-common) #top
M1122 (conf) #exit
M1122>
```

## 5.4.1 Main mode commands

Command	Show diagnostic log
Description	Displays diagnostic log.
Syntax	show log
Arguments	all
Example	
M1122> show log	
00/00:00:04 HI(1) ATM chann/vcc1/admin.stat up	
M1122>	

Command	Show DSL line status																																							
Description	Displays DSL line status																																							
Syntax	show dsl [all]																																							
Arguments	all																																							
<b>Example</b> M1122> show dsl  hardware-type ALCATEL/DMT hardware-rev 99111601/POTS/CP firmware-rev 00002508 activity-statusOPER/FULL  <table style="width: 100%; border-collapse: collapse;"> <thead> <tr> <th></th> <th style="text-align: center;">near-end</th> <th style="text-align: center;">far-end</th> </tr> </thead> <tbody> <tr> <td>maximum-bitrate</td> <td style="text-align: center;">5696kbits</td> <td style="text-align: center;">448kbits</td> </tr> <tr> <td>actual-bitrate</td> <td style="text-align: center;">4608kbits</td> <td style="text-align: center;">416kbits</td> </tr> <tr> <td>noise-margin</td> <td style="text-align: center;">3.5dB</td> <td style="text-align: center;">0.0dB</td> </tr> <tr> <td>output-power</td> <td style="text-align: center;">12.0dBm</td> <td style="text-align: center;">20dBm</td> </tr> <tr> <td>attenuation</td> <td style="text-align: center;">48.5dB</td> <td style="text-align: center;">0.0dB</td> </tr> <tr> <td>corr-fast-fec</td> <td style="text-align: center;">0</td> <td style="text-align: center;">0</td> </tr> <tr> <td>corr-intl-fec</td> <td style="text-align: center;">47</td> <td style="text-align: center;">0</td> </tr> <tr> <td>fail-fast-crc</td> <td style="text-align: center;">0</td> <td style="text-align: center;">0</td> </tr> <tr> <td>fail-intl-crc</td> <td style="text-align: center;">0</td> <td style="text-align: center;">0</td> </tr> <tr> <td>fail-fast-hec</td> <td style="text-align: center;">0</td> <td style="text-align: center;">0</td> </tr> <tr> <td>fail-intl-hec</td> <td style="text-align: center;">0</td> <td style="text-align: center;">658</td> </tr> <tr> <td>flaged-alarms</td> <td style="text-align: center;">NONE</td> <td style="text-align: center;">NONE</td> </tr> </tbody> </table> M1122>			near-end	far-end	maximum-bitrate	5696kbits	448kbits	actual-bitrate	4608kbits	416kbits	noise-margin	3.5dB	0.0dB	output-power	12.0dBm	20dBm	attenuation	48.5dB	0.0dB	corr-fast-fec	0	0	corr-intl-fec	47	0	fail-fast-crc	0	0	fail-intl-crc	0	0	fail-fast-hec	0	0	fail-intl-hec	0	658	flaged-alarms	NONE	NONE
	near-end	far-end																																						
maximum-bitrate	5696kbits	448kbits																																						
actual-bitrate	4608kbits	416kbits																																						
noise-margin	3.5dB	0.0dB																																						
output-power	12.0dBm	20dBm																																						
attenuation	48.5dB	0.0dB																																						
corr-fast-fec	0	0																																						
corr-intl-fec	47	0																																						
fail-fast-crc	0	0																																						
fail-intl-crc	0	0																																						
fail-fast-hec	0	0																																						
fail-intl-hec	0	658																																						
flaged-alarms	NONE	NONE																																						

Command	Show Ethernet interface status
Description	Displays Ethernet interface status
Syntax	show eth [all]
Arguments	show eth command shows Ethernet interface state and status. all argument shows also interrupts.
<b>Example</b> M1122> show eth ##eth(up)                    type IEEE 802.3/DIX pkt        oct        dis        err stat-tx-payload    10964    672919   0        0 stat-rx-payload    10968    657690   0        0 M1122>	

Command	Show ATM status
Description	Displays ATM status.
Syntax	show atm [all]
Arguments	show atm command shows active ATM channels and traffic statistics. all shows all ATM information.
<b>Example</b> <pre>M1122&gt; show atm ##vcc1 (up)   vpi   vci   type       encap                 0     35   DATA_PVC  ETH-LLC                  pkt     oct     dis     err stat-tx-payload 223641 2568289 0        0 stat-rx-payload 18030  1440816 0        0 M1122&gt;</pre>	

Command	Show bridge interface status
Description	Displays interfaces which have bridging enabled.
Syntax	show bridge if
Arguments	None
<b>Example</b> <pre>M1122&gt; show bridge if VBRI (up)      phys-address                 00:99:12:16:10:53 ETH (up)       phys-address                 00:00:00:00:00:00 VCC1 (up)      phys-address                 00:00:00:00:00:00 M1122&gt;</pre>	

<b>Command</b>	<b>Show bridging statistics</b>
Description	Displays bridging statistics.
Syntax	show bridge stat
Arguments	None
Example	<pre>M1122&gt; show bridge stat in-packet      8518      out-packet    8494 discard        24 M1122&gt;</pre>

<b>Command</b>	<b>Show bridging table</b>
Description	Displays bridging table.
Syntax	show bridge table
Arguments	None
Example	<pre>M1122&gt; show bridge table       if   phys-address      age   type VBRI  00:99:12:16:10:53 n/a   forever VCC1  00:60:08:94:da:a7 0      dynamic ETH   00:60:08:94:af:d7 0      dynamic nr-of-entries  3 M1122&gt;</pre>

<b>Command</b>	<b>Show PPTP information</b>
Description	Displays PPTP information
Syntax	show pptp
Arguments	None
Example	<pre>M1122&gt;show pptp VCC3 net-address      port status      host-cid peer-cid       n/a              n/a  IDLE        n/a      n/a       description       Office M1122&gt;</pre>

<b>Command</b>	<b>Show Address Resolution Protocol (ARP) table</b>
Description	Displays ARP table.
Syntax	show ip arp
Arguments	None
<b>Example</b>	
M1122>show ip arp	
VBRIDGE	net-address            phys-address            age
	10.98.20.140        00:00:0e:7c:15:d4        00.07
M1122>	

<b>Command</b>	<b>Show IP interfaces</b>
Description	Displays IP interfaces.
Syntax	show ip if
Arguments	None
<b>Example</b>	
M1122> show ip if	
VBRIDGE (up)	
net-address	net-mask            mtu   phys-address
192.168.172.2	255.255.255.0    1500 00:99:12:16:10:53
as ETHERNET/RIP DISABLED	
M1122>	

<b>Command</b>	<b>Show IP statistics</b>
Description	Displays IP statistics.
Syntax	show ip stat
Arguments	None
<b>Example</b>	
<pre>M1122&gt; show ip stat forwarding    NO FORWARD out-discards  0 default-ttl   255      out-no-routes  0 in-receives   2355     reasm-timeout  5 in-hdr-errors 0         reasm-reqds    0 in-addr-errors 1        reasm-OKs      0 forw-datagrams 0        reasm-fails    0 in-unknown-protos 0      frag-OKs       0 in-discards   2354     frag-fails     0 in-delivers   2354     frag-creates   0 out-requests  0        routing-discards0 M1122&gt;</pre>	

<b>Command</b>	<b>Show IP cache table and statistics</b>
Description	Displays IP cache table and statistics.
Syntax	show ip cache
Arguments	None
<b>Example</b>	
<pre>M1122&gt; show ip cache if    net-address  phys-header ETH  192.168.1.3  005004b67d680040430236720800 ETH  192.168.1.2  005004b669750040430236720800 VCC2 10.98.16.250 0021 nr-of-entries  3 M1122&gt;</pre>	

Command	Show IP routing table
Description	Displays IP routing table.
Syntax	show ip route
Arguments	None
<b>Example</b> <pre> M1122&gt;show ip route VBRIDGE route-dest  route-mask      netxthop      tag 10.98.20.255 255.255.255.255 255.255.255.255 BCAST 10.98.20.150 255.255.255.255 10.98.20.150   IFACE 10.98.20.0   255.255.255.0   10.98.20.150   LOCAL MNGTVCC route-dest  route-mask      netxthop      tag 10.98.9.0   255.255.255.0   10.98.5.200    RIP 10.98.5.255 255.255.255.255 255.255.255.255 BCAST 10.98.5.100 255.255.255.255 10.98.5.100    IFACE 10.98.5.0   255.255.255.0   10.98.5.100    LOCAL ETH route-dest  route-mask      netxthop      tag 10.98.0.255 255.255.255.255 255.255.255.255 BCAST 10.98.0.254 255.255.255.255 10.98.0.254    IFACE 10.98.0.0   255.255.255.0   10.98.0.154    LOCAL VCC3 route-dest  route-mask      netxthop      tag 11.22.20.255 255.255.255.255 255.255.255.255 BCAST 11.22.20.108 255.255.255.255 11.22.20.108   IFACE 11.22.20.0   255.255.255.0   11.22.20.108   LOCAL 0.0.0.0     0.0.0.0         11.22.20.1     STAT M1122&gt; </pre>	



Command	Show Internet Control Message Protocol statistics
Description	Displays ICMP statistics.
Syntax	show ip icmp
Arguments	None
<b>Example</b>	
M1122> show ip icmp	
in-msgs                    23 out-msgs                    23	
in-errors                 0 out-errors                 0	
in-dest-unreachs        0 out-dest-unreachs        0	
in-time-excds            0 out-time-excds            0	
in-parm-probs            0 out-parm-probs            0	
in-src-quenchs           0 out-src-quenchs           0	
in-redirects             0 out-redirects             0	
in-echos                 23 out-echos                 23	
in-echo-reps             0 out-echo-reps             0	
in-timestamps            0 out-timestamps            0	
in-timestamp-reps       0 out-timestamp-reps       0	
in-addr-masks            0 out-addr-masks            0	
in-addr-mask-reps       0 out-addr-mask-reps       0	
M1122>	

Command	Show User Datagram Protocol statistics
Description	Displays UDP statistics.
Syntax	show ip udp
Arguments	None
<b>Example</b>	
M1122> show ip udp	
in-datagrams             0 in-errors                    0	
no-ports                 0 out-datagrams               0	
M1122>	

Command	Show Transmission Control statistics
Description	Displays TCP statistics.
Syntax	show ip tcp
Arguments	None
<b>Example</b> M1122> show ip tcp rto-algorithm        VANJ        estab-resets        0 rto-min                0                curr-estab        0 rto-max                240000        in-segs            0 max-conn               16               out-segs            0 active-opens           0                retrans-segs       0 passive-opens          0                in-errs            0 attemp-fails           0                out-rsts            0 M1122>	

Command	Show Routing Information Protocol statistics
Description	Displays RIP statistics.
Syntax	show ip rip
Arguments	None
<b>Example</b> M1122> show ip rip in-pkts                0                out-pkts            0 in-updates             0                out-updates        0 in-requests            0                out-requests       0 M1122>	

Command	Show SNMP statistics
Description	Displays SNMP statistics.
Syntax	show ip snmp
Arguments	None.
<b>Example</b> M1122> show ip snmp M1122>	

<b>Command</b>	<b>Show Network Address Port Translation Protocol table entries</b>
Description	Displays NAPT table entries.
Syntax	show napt table
Arguments	None.
<b>Example</b> <pre>M1122&gt;show napt table Private IP   Port Public IP   Port Peer IP       Port Prot Flgs T 192.15.0.1   512 10.98.20.10 7500 10.98.16.25 0    ICMP 0x00 0 192.15.1.1   768 10.98.20.10 7501 10.98.16.25 0    ICMP 0x00 1 192.15.1.1   1959 10.98.20.10 50008131.228.51.32 9494 UDP 0x00 14 M1122&gt;</pre>	

<b>Command</b>	<b>Show Network Address Port Translation Protocol resources</b>
Description	Displays used and available NAPT resources.
Syntax	show napt
Arguments	None.
<b>Example</b> <pre>M1122&gt; show napt NAPT resource summary           Start   End     Used Free Public TCP ports 50000 59999   0   10000 Public UDP ports 50000 59999   1    9999 NAPT Entries           3    9997 NAPT Hash Entries      6   19994 M1122&gt;</pre>	

<b>Command</b>	<b>Show Network Address Port Translation Protocol servers (pinholes)</b>
Description	Displays NAPT server information.
Syntax	show napt server
Arguments	None.
<b>Example</b> <pre>M1122&gt; show napt server VCC3   net-address  port-mappings  size prot "nat"  192.168.0.1  21&lt;-&gt;21       1    TCP M1122&gt;</pre>	

<b>Command</b>	<b>Show Domain Name Server entry table and statistics</b>
Description	Displays DNS entry table and statistics.
Syntax	show dns
Arguments	None.
<b>Example</b> M1122> show dns dns-proxy "Mxx"/"Nokia Mxx"/AUTOMATIC M1122>	

<b>Command</b>	<b>Show Dynamic Host Configuration Protocol server entry table and statistics</b>
Description	Displays DHCP server entry table and statistics. It also shows leased address and states.
Syntax	show dhcp server
Arguments	None.
<b>Example</b> M1122> show dhcp server ##scope (a) pool-address pool-last pool-mask 192.168.0.1 192.168.0.254 255.255.255.0 net-binding primary-dns secondary-dns ETH 192.168.0.254 n/a lease-time gateway domain-name 00/01:00:00 12.168.0.254 n/a ##scope (b) pool-address pool-last pool-mask 192.168.1.1 192.168.1.254 255.255.255.0 net-binding primary-dns secondary-dns VBRIDGE 192.168.1.254 n/a lease-time gateway domain-name 00/01:00:00 192.168.1.254 n/a M1122>	

Command	Show M1122 information
Description	Displays M1122 hardware and software information.
Syntax	show status [session   performance]
Arguments	Optional arguments <code>session</code> and <code>performance</code> . <code>session</code> shows information of the active configuration sessions. If <code>login-id</code> is used, it is shown on the screen. <code>performance</code> shows error counters.
Example	<pre>M1122&gt; show status product-id          T66280.01 serial-num          61000206829 cpu-type            XPC850SR / B flash-type          2 M sdram-type          8 M phys-address-lan    00:40:43:02:36:80 phys-address-wan    00:40:43:02:36:81 short-desc          M1122 long-desc           NOKIA M1122                    ADSL router boot-version        B-R0.0.8 appl-version        Gx1x2200.R00 log-severity        HIGH start-uptime        00/00:37:26 M1122&gt;</pre>

Command	Show running configuration
Description	Displays currently active configuration. If you have made changes in the configuration and you want them to be active after restart, save the current configuration to startup.cfg file using <code>save config</code> command.
Syntax	<code>show config running</code>
Arguments	None
Example	<pre>M1122&gt; show config running system     hostname M1122 eth     ip address 192.168.172.148     255.255.255.128 vcc1     pvc 0 155 tunneled-ppp-vc     bridging vcc2     pvc 0 156 ppp-vc     ip address 0.0.0.0 0.0.0.0     ppp authentication chap     ppp username nokia     ppp password mypassword vbridge mngtvcc common M1122&gt;</pre>

Command	Show startup configuration
Description	Displays the startup configuration of your M1122. This is the configuration saved in the startup.cfg file. Startup.cfg file is activated when M1122 is switched on. If the startup.cfg file is missing, the default configuration is used.
Syntax	show config startup
Arguments	None
<b>Example</b> M1122> show config startup system hostname M1122 eth ip address 192.168.172.148 255.255.255.128 vcc1 pvc 0 155 tunneled-ppp-vc bridging vbridge mngtvcc common M1122>	

Command	Show default configuration
Description	Displays the default configuration of M1122. M1122 uses this configuration if the startup.cfg file is missing.
Syntax	show config default
Arguments	None
<b>Example</b> M1122> show config default system hostname Mxx eth bridging vcc1 pvc 0 100 eth-llc bridging vbridge mngtvcc common M1122>	

Command	Show configuration file
Description	Displays the local configuration file
Syntax	show config file <filename>
Arguments	filename is the name of the local configuration file.
<b>Example</b> M1122> show config file startup.cfg M1122>	

Command	Show debug status
Description	Displays the status (ON/OFF) of the debug functions.
Syntax	show debug
Arguments	None.
<b>Example</b> M1122> show debug log                   OFF   dsl                   OFF eth                   OFF   atm-aal0           OFF atm-aal5           OFF   ppp                 OFF pptp                 OFF   arp                 OFF ip-host             OFF   ip-forward         OFF ip-icmp             OFF   napt-map           OFF napt-entry          OFF   napt-internal      OFF napt-h323           OFF   dhcp                OFF dns                  OFF M1122>	

Command	Ping
Description	Send an ICMP echo request to an IP address to test the IP function.
Syntax	ping <ip-address>
Arguments	ip-address is the IP address of the ping destination in dotted decimal format.
<b>Example</b> M1122> ping 198.168.172.23 Reply from 198.168.172.23: bytes 32 time <10ms TTL=128 M1122>	



Command	ATMping
Description	Sends five OAM F5 loopback cells to the specified VPI/VCI destination with a 5 second total timeout interval. You can use ATMping to test the ATM connection.
Syntax	atmping <vpi> <vci> <range>
Arguments	vpi is the Virtual Path Identifier and vci is the Virtual Channel Identifier of the ATM channel you want to test. vpi values are integers (0...255). vci values are integers (0...65535) range values are segment and end-to-end depending whether you want to test the first segment of the ATM connection or the end-to-end connection.
Example	<pre>M1122&gt; atm ping 0 23 segment reply asserted roundtrip time = 4.20 ms M1122&gt;</pre>

The debug commands are used to solve difficult problem situations. The debugging can be switched off with the following command. Other debugging commands are not handled in this manual.

Command	Switch off debug
Description	Switches all debug operations off. To quit debugging, write no debug all on the screen regardless of what is being printed on the screen.
Syntax	no debug all
Arguments	no switches debugging off.
Example	<pre>M1122&gt; no debug all M1122&gt;</pre>

Command	Show contents of file directory
Description	Displays the contents of M1122 file directory.
Syntax	dir
Arguments	None
<b>Example</b> M1122> dir <pre>           filename      size      appl-version           startup.cfg   195           image.exe     375007   Gx1x2200.R00 nr-of-files 2 avail-media 1454306 bytes M1122&gt;</pre>	

Command	Copy file
Description	Copies files within M1122 or over a TFTP (Trivial File Transfer Protocol) connection. With this command you can, for example, download configuration files.
Syntax	<pre> copy [file:/] &lt;src-filename&gt; [file:/] &lt;dst-filename&gt; copy [file:/] &lt;src-filename&gt; tftp:&lt;ip-address&gt;/&lt;../dst-filename&gt; copy tftp:&lt;ip-address&gt;/&lt;../src-filename&gt; [file:/] &lt;dst-filename&gt;</pre>
Arguments	src-filename is the name of the file you want to copy. dst-filename is its destination filename. ip-address is the IP address of the TFTP server.
<b>Example</b> M1122>copy tftp:/191.111.111.1/file.txt file.new M1122>	

<b>Command</b>	<b>Rename file</b>
Description	Renames a file
Syntax	rename <old-filename> <new-filename>
Arguments	old-filename is the name of the file you want to re-name. new-filename is the new filename.
Example	<pre>M1122&gt; rename newconfig oldconfig M1122&gt;</pre>

<b>Command</b>	<b>Delete file</b>
Description	Deletes a file
Syntax	delete <del-filename>
Arguments	del-filename is the name of the file you want to delete.
Example	<pre>M1122&gt; delete oldfile M1122&gt;</pre>

<b>Command</b>	<b>Download new firmware</b>
Description	Downloads a new firmware from a TFTP server. Remember to restart M1122 after downloading to activate the new firmware.
Syntax	install tftp:<ip-address>/<./src-filename>
Arguments	ip-address is the IP address of the TFTP server. src-filename is the name of the file which contains the new software.
Example	<pre>M1122&gt; install tftp:/10.98.20.6/appl-A0.4.2 blocks received transfer status SUCCESSFUL M1122&gt; restart ...</pre>

<b>Command</b>	<b>Execute a command batch</b>
Description	Executes a custom command batch.
Syntax	script <batch-filename>
Arguments	batch-filename is the name of the file in which you want to execute.
Example	<pre>M1122&gt;script swap.bat M1122&gt;</pre>

<b>Command</b>	<b>Save log to file</b>
Description	Saves log to a file.
Syntax	save log file<log-filename>
Arguments	log-filename is the name of the file in which you want to save the log.
Example	<pre>M1122&gt;save log file log.txt M1122&gt;</pre>

<b>Command</b>	<b>Save log to a default file</b>
Description	Saves log with a default file name (default.log).
Syntax	save log default
Arguments	None
Example	<pre>M1122&gt;save log default M1122&gt;</pre>

<b>Command</b>	<b>Save configuration to file</b>
Description	Saves the configuration to a file.
Syntax	save config {file<filename>   startup   user}
Arguments	filename is the name of the file in which you want to save the configuration. startup-config argument saves the configuration into a startup.cfg file. user saves the user configuration.
Example	<pre>M1122&gt;save config startup-config M1122&gt;</pre>

<b>Command</b>	<b>Restore configuration</b>
Description	Restores the default or user configuration. You must have the admin privileges to issue this command. Restart your M1122 after you have issued this command.
Syntax	restore config {default   user}
Arguments	default argument restores the default configuration of M1122. user argument restores the user configuration. The user configuration can be made with admin rights only.
Example	<pre>M1122&gt;restore config default M1122&gt;</pre>

<b>Command</b>	<b>Clear counters</b>
Description	Clears the statistics counters.
Syntax	clear {log   eth   atm   bridge   ppp   ip}
Arguments	log argument rewinds the diagnostic log to the beginning of the log file. eth argument clears the Ethernet statistics counters. atm argument clears the ATM statistics counters. bridge argument clears the bridging counters. ppp argument clears the PPP counters. ip argument clears the IP statistics counters.
Example	<pre>M1122&gt; clear log M1122&gt;</pre>

Command	Reset subsystem
Description	Resets subsystems.
Syntax	reset {log   dsl   ppp [vcc-id]   arp   bridge   napt}
Arguments	<p>log resets the diagnostic log subsystem.</p> <p>dsl resets the DSL subsystem. The DSL connection will be re-established.</p> <p>ppp resets the whole PPP subsystem. The PPP connection will be re-established. If you provide a VCC number (vcc-id), only that connection will be reseted.</p> <p>arp clears the ARP table.</p> <p>bridge clears the bridge table.</p> <p>napt resets the NAPT subsystem.</p>
<b>Example</b> M1122> reset ppp M1122>	

Command	Logout
Description	Logs out from the command line interface.
Syntax	logout
Arguments	None
<b>Example</b> M1122>logout	

Command	Fast restart M1122
Description	Restarts M1122 software.
Syntax	reload
Arguments	None
<b>Example</b> M1122>reload in progress...	

<b>Command</b>	<b>Restart M1122</b>
Description	Restarts M1122. This command is equivalent to switching the power first off and then on.
Syntax	restart
Arguments	None
Example	<pre>M1122&gt; restart in progress...</pre>

<b>Command</b>	<b>Switch to configuration mode</b>
Description	Switches to the configuration mode. The configuration mode lets you change the configuration of M1122.
Syntax	configure
Arguments	None
Example	<pre>M1122&gt;configure M1122 (conf) #</pre>

### 5.4.2 Configuration mode commands

<b>Command</b>	<b>Return to root level</b>
Description	Returns you to the root level from a higher configuration level.
Syntax	top
Arguments	None.
Example	<pre>M1122 (conf-system) #top M1122 (conf) #</pre>

## Root level commands

Command	Show current running configuration
Description	Displays currently running configuration.
Syntax	show
Arguments	None
Example	
<pre>M1122 (conf) # show system     hostname M1122 eth     bridging  vcc1     pvc 0 100 eth-llc     bridging  vcc2 vcc3 vcc4 vcc5 vcc6 vcc7 vcc8 vbridge mngtvcc common M1122 &gt;</pre>	

show command given on different configuration levels displays the current configuration of that particular configuration level.

Use the following commands to enter different configuration levels:

```
system
password
eth
vcc1 ... vcc8
vbridge
mngtvcc
common
```



## System level commands

Command	Assign hostname
Description	Assigns a hostname to M1122.
Syntax	hostname <name-string>
Arguments	name-string is an ASCII string of maximum of 32 characters.
Example	<pre>M1122 (conf-system) #hostname nokia nokia (conf-system) #</pre>

Command	Set configuration session timeout
Description	Sets a timeout for a management session.
Syntax	timeout <value>
Arguments	value is a time from 1 to 255 minutes.
Example	<pre>M1122 (conf-system) #timeout 10 nokia (conf-system) #</pre>

**Password level command**

Command	Assign new password
Description	Switches password on/off and sets a new password for different user levels. Note, that you must assign admin password before you can assign other passwords. When removing passwords, admin password must be removed last.
Syntax	[no] {user   bridge-user   router-user   ptp-user   napt-user   admin} <passwd-string>
Arguments	<p><code>no</code> switches off user password.</p> <p><code>user</code> argument sets the user privilege level password. User password gives no access to the configuration mode. Also, firmware download is not allowed on the user privilege level.</p> <p><code>bridge-user</code> sets the bridge-user privilege level password. Bridge user can set static routes and enable VBRIDGE IP address.</p> <p><code>router-user</code> sets the router-user privilege level password. Router user can change log levels and host-name.</p> <p><code>ptp-user</code> sets the PPTP-user privilege level password. PPTP user can change VCCx description, DHCP, DNS and LAN/VBRIDGE configurations.</p> <p><code>napt-user</code> set the NAPT-user privilege level password. NAPT user can change VCCx description, LAN/VBRIDGE, NAPT servers (pinholes), PPP username/password/mode/autostop, DHCP, DNS configurations, and set static routes.</p> <p><code>admin</code> sets the administrator privilege level password. Administrator can change all configuration parameters. Only the administrator is allowed to use file handling commands (copy, rename, etc.).</p> <p><code>passwd-string</code> is the new password.</p>
Example	<pre>M1122&gt; admin nokia M1122</pre>

## Ethernet level commands

Command	Switch on/off bridging
Description	Switches on/off bridging.
Syntax	[no] bridging
Arguments	no switches bridging off.
Example	<pre>M1122 (conf-eth) #bridging M1122 (conf-eth) #</pre>

Command	Switch on/off IP function in Ethernet interface
Description	Switches on/off IP function in the Ethernet interface.
Syntax	[no] ip address <ip-address> <ip-mask>
Arguments	no switches IP function off. ip-address is the IP address you want to assign to the Ethernet interface. ip-mask is the subnet mask.
Example	<pre>M1122 (conf-eth) #ip address 192.168.132.11 255.255.255.0 M1122 (conf-eth) #</pre>

Command	Switch on/off RIP send function in Ethernet interface
Description	Switches on/off RIP send function. When enabled M1122 sends Routing Information Protocol messages to other routers.
Syntax	[no] ip rip-send {rip-send-mode}
Arguments	no switches rip-send function off. v1 send-mode selects RIP version 1. v2 send-mode selects RIP version 2. compatible-v1 send-mode selects the sending of RIPv2 packets using broadcast.
Example	<pre>M1122 (conf-eth) #ip rip-send v1 M1122 (conf-eth) #</pre>

<b>Command</b>	<b>Switch on/off RIP receive function in Ethernet interface</b>
Description	Switches on/off RIP send function. When enabled M1122 receives Routing Information Protocol messages from other routers.
Syntax	[no] ip rip-receive {rip-receive-mode}
Arguments	no switches RIP receive function off. v1 receive-mode selects RIP version 1. v2 receive-mode selects RIP version 2. both-v1v2 receive-mode selects both RIP version 1 and version 2.
<b>Example</b> M1122 (conf-eth)#ip rip-receive v1 M1122 (conf-eth)#	

<b>Command</b>	<b>Disable/enable management through the Ethernet interface</b>
Description	Enables/disables the management of M1122 through the Ethernet interface.
Syntax	[no] ip admin-disabled
Arguments	no enables management through the Ethernet interface.
<b>Example</b> M1122 (conf-eth)#ip admin-disabled M1122 (conf-eth)#	

### VCC (ATM channel) commands

Command	Activate ATM channel
Description	Activates an ATM channel and sets the encapsulation for that channel.
Syntax	[no] pvc <vpi> <vci> <encap>
Arguments	<p><code>no</code> deactivates the ATM channel.</p> <p><code>vpi</code> is the Virtual Path Identifier of the ATM channel. Possible values are 0...255.</p> <p><code>vci</code> is the Virtual Channel Identifier of the ATM channel. Possible values are 0...65535.</p> <p><code>encap</code> is the encapsulation of the ATM channel. The encapsulations are <code>auto-llc</code>, <code>eth-llc</code>, <code>ip-llc</code>, <code>ppp-vc</code>, and <code>tunneled-ppp-vc</code>. <code>auto-llc</code> encapsulates the routed packets in <code>ip-llc</code> and the bridged packets in <code>eth-llc</code>.</p>
Example	<pre>M1122 (conf-vccx)#pvc 0 100 ip-llc M1122 (conf-vccx)#</pre>

Command	Switch on/off bridging
Description	Switches bridging on/off on the specified ATM channel.
Syntax	[no] bridging
Arguments	<code>no</code> switches off bridging.
Example	<pre>M1122 (conf-vccx)#bridging M1122 (conf-vccx)#</pre>

Command	Switch on/off PPP authentication
Description	Switches PPP authentication on/off on the specified ATM channel.
Syntax	[no] ppp authentication {mode}
Arguments	no switches off PPP authentication. chap mode selects Challenge Handshake Authentication Protocol. pap mode selects Password Authentication Protocol. both-chap-pap mode selects both authentication protocols.
<b>Example</b> M1122 (conf-vccx) #ppp authentication chap M1122 (conf-vccx) #	

Command	Set PPP username
Description	Sets the username used in PPP authentication.
Syntax	[no] ppp username <name-string>
Arguments	no deletes PPP username. name-string is your PPP username. The maximum length of the username is 15 characters.
<b>Example</b> M1122 (conf-vccx) #ppp username ut32aj M1122 (conf-vccx) #	

Command	Set PPP password
Description	Sets the password used in PPP authentication.
Syntax	[no] ppp password <passwd-string>
Arguments	no deletes PPP password. passwd-string is the PPP password. The password must be 4...15 characters long.
<b>Example</b> M1122 (conf-vccx) #ppp password jfddslfj M1122 (conf-vccx) #	

<b>Command</b>	<b>Stop PPP negotiation when authentication failure occurs</b>
Description	When enabled, the authentication failure causes the PPP negotiation to stop. The command <code>reset ppp vccx</code> is required to restart the PPP negotiation.
Syntax	<code>[no] ppp autostop</code>
Arguments	<code>no</code> disables PPP autostop.
Example	<pre>M1122 (conf-vccx) # ppp autostop M1122 (conf-vccx) #</pre>

<b>Command</b>	<b>Switch on/off IP function on ATM channel</b>
Description	Switches on/off IP function on the ATM channel.
Syntax	<code>[no] ip address &lt;ip-address&gt; &lt;ip-mask&gt;</code>
Arguments	<code>no</code> switches IP function off. <code>ip-address</code> is the IP address you want to assign to the ATM channel. IP address 0.0.0.0 with subnet mask 0.0.0.0 can be used with <code>ppp-vc</code> encapsulation if the dynamic IP address negotiation is required. <code>ip-mask</code> is the subnet mask.
Example	<pre>M1122 (conf-vccx) # ip address 192.168.132.13 255.255.255.0 M1122 (conf-vccx) #</pre>

<b>Command</b>	<b>Switch on/off RIP send function on ATM channel</b>
Description	Switches on/off RIP send function. When enabled, M1122 sends Routing Information Protocol messages to other routers.
Syntax	<code>[no] ip rip-send {rip-send-mode}</code>
Arguments	<code>no</code> switches rip-send function off. <code>v1</code> send-mode selects RIP version 1. <code>v2</code> send-mode selects RIP version 2. <code>compatible-v1</code> send-mode selects the sending of RIPv2 packets using broadcast.
Example	<pre>M1122 (conf-vccx) # ip rip-send v1 M1122 (conf-vccx) #</pre>

<b>Command</b>	<b>Switch on/off RIP receive function on ATM channel</b>
Description	Switches on/off RIP receive function. When enabled, M1122 receives Routing Information Protocol messages from other routers.
Syntax	[no] ip rip-receive {rip-receive-mode}
Arguments	no switches RIP receive function off. v1 receive-mode selects RIP version 1. v2 receive-mode selects RIP version 2. both-v1v2 receive-mode selects both RIP version 1 and version 2.
<b>Example</b> M1122 (conf-vccx) #ip rip-receive v1 M1122 (conf-vccx) #	

<b>Command</b>	<b>Enable Network Address Port Translation</b>
Description	Enables Network Address Port Translation.
Syntax	[no] ip napt
Arguments	no switches NAPT function off.
<b>Example</b> M1122 (conf-vccx) #ip napt M1122 (conf-vccx) #	



<b>Command</b>	<b>Set server support entry</b>
Description	Sets a NAPT server support entry.
Syntax	[no] ip server-napt <pool-string><hidden-address> <hidden-pool-base> <public-pool-base> <pool-size> <protocol-id>
Arguments	no deletes pinhole entry. pool-string identifies the server entry. hidden-address is the address of the local server for which the pinhole is made. hidden-pool-base is the start of the local port range. public-pool-base is the start of the external port range. pool-size is the size of the port range. protocol-id is the protocol allowed through the pinhole. Available protocols are: UDP, TCP, PPTP-GRE, and ESP-IPSEC  Example: When hidden-pool-base is 80, public-pool-base is 80 and pool-size is 1, traffic coming to external port (WAN port) 80 will be mapped to internal port 80.
Example	<pre>M1122(conf-vccx)#ip server-napt web_server 192.168.1.100 80 80 1 tcp M1122(conf-vccx)#</pre>

<b>Command</b>	<b>Disable/enable management through the ATM channel</b>
Description	Enables/disables the management of M1122 through the ATM channel.
Syntax	[no] ip admin-disabled
Arguments	no enables management through the ATM channel.
Example	<pre>M1122(conf-vccx)#ip admin-disabled M1122(conf-vccx)#</pre>

**Vbridge commands**

<b>Command</b>	<b>Switch on/off IP function in vbridge</b>
Description	Switches on/off IP function.
Syntax	[no] ip address <ip-address> <ip-mask>
Arguments	no switches off IP function. ip-address is the IP address of the Vbridge in dotted decimal notation. ip-mask is the subnet mask in dotted decimal notation.
<b>Example</b> M1122 (conf-vbridge)#ip address nnn.nnn.nnn.nnn 255.255.255.0 M1122 (conf-vbridge)#	

<b>Command</b>	<b>Switch on/off RIP receive function in vbridge</b>
Description	Switches on/off RIP receive function. When enabled, M1122 receives Routing Information Protocol messages from other routers.
Syntax	[no] ip rip-receive {rip-receive-mode}
Arguments	no switches RIP receive function off. v1 receive-mode selects RIP version 1. v2 receive-mode selects RIP version 2. both-v1v2 receive-mode selects both RIP version 1 and version 2.
<b>Example</b> M1122 (conf-vbridge)#ip rip-receive v1 M1122 (conf-vbridge)#	

<b>Command</b>	<b>Disable/enable management through the vbridge</b>
Description	Enables/disables the management of M1122 through the vbridge.
Syntax	[no] ip admin-disabled
Arguments	no enables management through the ATM channel.
<b>Example</b> M1122 (conf-vbridge)#ip admin-disabled M1122 (conf-vbridge)#	

<b>Command</b>	<b>Switch on/off VCC-to-VCC bridging</b>
Description	Switches on/off bridging between ATM channels.
Syntax	[no] interwan-bridging
Arguments	no switches off bridging between ATM channels.
Example	<pre>M1122 (conf-vbridge) #interwan-bridging M1122 (conf-vbridge) #</pre>

### Dedicated management channel commands

<b>Command</b>	<b>Activate dedicated management channel</b>
Description	Activates a dedicated management channel and sets the encapsulation for that channel.
Syntax	[no] pvc <vpi> <vci> <encap>
Arguments	no deactivates the ATM channel. vpi is the Virtual Path Identifier of the ATM channel. Possible values are 0...255. vci is the Virtual Channel Identifier of the ATM channel. Possible values are 0...65535. encap is the encapsulation of the ATM channel. Encapsulations are ppp-vc, eth-llc, and ip-llc.
Example	<pre>M1122 (conf-mngtvcc) #pvc 0 100 eth-llc M1122 (conf-mngtvcc) #</pre>

<b>Command</b>	<b>Switch on/off IP function on dedicated management channel</b>
Description	Switches on/off IP function.
Syntax	[no] ip address <ip-address> <ip-mask>
Arguments	no switches off IP function. ip-address is the IP address of the Vbridge in dotted decimal notation. IP address 0.0.0.0 with subnet mask 0.0.0.0 can be used with ppp-vc encapsulation if the dynamic IP address negotiation is required. ip-mask is the subnet mask in dotted decimal notation.
<b>Example</b> M1122 (conf-mngtvcc) #ip address nnn.nnn.nnn.nnn 255.255.255.0 M1122 (conf-mngtvcc) #	

<b>Command</b>	<b>Switch on/off RIP receive function on dedicated management channel</b>
Description	Switches on/off RIP receive function.
Syntax	[no] ip rip-receive {rip-receive-mode}
Arguments	no switches rip-send function off. v1 receive-mode selects RIP version 1. v2 receive-mode selects RIP version 2. both-v1v2 receive-mode selects both RIP version 1 and version 2.
<b>Example</b> M1122 (conf-mngtvcc) #ip rip-receive v1 M1122 (conf-mngtvcc) #	

**Common commands**

<b>Command</b>	<b>Set PPP packet size</b>
Description	Sets the maximum size of the received PPP packets.
Syntax	[de] ppp mru <size>
Arguments	size is the size of a PPP packet. Default size is 1500.
<b>Example</b> M1122 (conf-common) #ppp mru 1000 M1122 (conf-common) #	

<b>Command</b>	<b>Set PPP restart time parameter</b>
Description	Defines how long M1122 waits for the configure-request packet.
Syntax	[de] ppp restart <time>
Arguments	time in seconds.
Example	<pre>M1122 (conf-common) #ppp restart 5 M1122 (conf-common) #</pre>

<b>Command</b>	<b>Set max-config parameter value</b>
Description	Defines how many times the configure-request packet will be sent.
Syntax	[de] ppp max-config <pkt-count>
Arguments	pkt-count is the number of configure request packets, values 1...30.
Example	<pre>M1122 (conf-common) #ppp max-config 10 M1122 (conf-common) #</pre>

<b>Command</b>	<b>Set max-terminate parameter value</b>
Description	Defines how many terminate-request packets will be sent before M1122 decides that the connection is down.
Syntax	[de] ppp max-terminate <pkt-count>
Arguments	pkt-count is the number of configure request packets, values 1...30.
Example	<pre>M1122 (conf-common) #ppp max-terminate 10 M1122 (conf-common) #</pre>

Command	Set max-failure parameter value
Description	Defines how many times PPP options will be offered before the negotiation fails.
Syntax	[de] ppp max-failure <pkt-count>
Arguments	pkt-count is the number of packets, values 1...30.
<b>Example</b> M1122 (conf-common) # ppp max-failure 10 M1122 (conf-common) #	

Command	Switch on/off IP cache
Description	Switches IP cache on/off. Enabled IP cache increases the speed of the IP packet forwarding.
Syntax	[no] ip cache
Arguments	no switches IP cache off.
<b>Example</b> M1122 (conf-common) # M1122 (conf-common) #	

Command	Add/delete IP route
Description	Adds/deletes an IP route
Syntax	[no] ip route <dest-net> <net-mask> <gateway> <if>
Arguments	no deletes an IP route. dest-net is the IP address of the destination in the dotted decimal notation. net-mask is the subnet mask of the destination in dotted decimal notation. gateway is the default gateway for the route. if is the interface through which the destination can be reached, vbridge or mngtvcc.
<b>Example</b> M1122 (conf-common) # ip route 131.112.11.1 255.255.255.0 131.2.111.2 mngtvcc M1122 (conf-common) #	

<b>Command</b>	<b>Define and activate host access list</b>
Description	You can define up to four IP addresses from which MW 1122 can be accessed using telnet or http. If you define one or more addresses, M1122 can be accessed from the specified addresses only.
Syntax	[no] ip host-acl <ip-address> <ip-mask>
Arguments	no switches host access list off. ip-address is the allowed host address and ip-mask is its subnet mask.
Example	<pre>M1122 (conf-common) #ip host-acl 192.168.1.17 255.255.255.0 M1122 (conf-common) #</pre>

<b>Command</b>	<b>Switch on/off dynamic host configuration protocol</b>
Description	Switches on/off dynamic host configuration protocol.
Syntax	[no] dhcp mode <service>
Arguments	no switches off DHCP. service parameter value is server when you want to use M1122 as a DHCP server.
Example	<pre>M1122 (conf-common) #dhcp mode server M1122 (conf-common) #</pre>

<b>Command</b>	<b>Set DHCP address range</b>
Description	You can define to DHCP address ranges with this command. The default pool is the IP address of the interface with a subnet mask 255.255.255.0. If you don't define an address range, up to two ranges will be defined automatically for ETH/VBRIDGE interfaces, in this order, if the interface has an IP address.
Syntax	[no] dhcp address <scope> <pool-base> <pool-mask> <pool-size>
Arguments	no switches of address pool. scope defines the pool. Values are 1 and 2. pool-base is the first IP address in the pool in dotted decimal format. pool-mask is the subnet mask of the pool addresses. pool-size is the size of the address pool, 0...254.
Example	<pre>M1122 (conf-common) #dhcp address 1 168.190.1.1 255.255.255.0 100 M1122 (conf-common) #</pre>

<b>Command</b>	<b>Set DNS address for DHCP clients</b>
Description	Defines a DNS address for the DHCP clients.
Syntax	[de   no] dhcp dns <scope> <class> <dns-server>
Arguments	scope defines the DHCP pool (1 or 2). class defines whether the server is a primary or a secondary server. dns-server is the IP address of the DNS server.
Example	<pre>M1122 (conf-common) #dhcp dns 1 primary 190.168.2.1 M1122 (conf-common) #</pre>



<b>Command</b>	<b>Set DHCP server lease time</b>
Description	Defines the time how often the PC has to renew its DHCP lease.
Syntax	[de   no] dhcp lease-time <scope> <time-count>
Arguments	scope defines the DHCP pool (1 or 2). time-count is the renewal interval in minutes, 1...65535.
Example	<pre>M1122 (conf-common) #dhcp lease-time 1 360 M1122 (conf-common) #</pre>

<b>Command</b>	<b>Set DHCP pool domain name</b>
Description	Set the domain name for the DHCP pool. The domain name is used to show the client in which network the client is in.
Syntax	[no] dhcp domain-name <scope> <name-string>
Arguments	scope defines the DHCP pool (1 or 2). name-string set the domain name.
Example	<pre>M1122 (conf-common) #dhcp domain-name 1 nokia M1122 (conf-common) #</pre>

<b>Command</b>	<b>Set Domain name server address</b>
Description	Defines the address of the domain name server used by M1122.
Syntax	[no] dns <class> <dns-server>
Arguments	no deletes domain name server address. class defines whether the server is a primary or a secondary name server. dns-server is the IP address of the DNS server.
Example	<pre>M1122 (conf-common) #dns primary 190.168.12.1 M1122 (conf-common) #</pre>

<b>Command</b>	<b>Switch on/off weighted fair queueing</b>
Description	Switches on/off weighted fair queueing.
Syntax	[no] misc global-wfq
Arguments	no switches off weighted fair queueing.
Example	
M1122 (conf-common)#misc global-wfq	
M1122 (conf-common)#	

<b>Command</b>	<b>Switch between full-rate ADSL and ADSL lite</b>
Description	Switches between full-rate ADSL and ADSL lite. Note, G.992.2.
Syntax	[no] misc dmt-mode-lite
Arguments	no switches to full-rate ADSL.
Example	
M1122 (conf-common)#misc dmt-mode-lite	
M1122 (conf-common)#	



## Appendix A

### Technical specifications

<b>Features</b>	
<b>ADSL</b>	
Physical layer	ANSI T1.413 Issue 2 (ANSI ADSL), ITU-T G.992.1 (ITU-T ADSL), and ITU-T G.994.1 (Handshake) compatible.
ADSL line connector	RJ-11
<b>ATM over ADSL</b>	
ATM connections	PVC, up to 8 virtual circuits
Service categories	UBR
Encapsulations	RFC2684 ETH-LLC, RFC2684 IP-LLC, RFC2364 PPP-VC, RFC2364 TUNNELED-PPP-VC
<b>Ethernet interface</b>	
Ethernet	10Base-T, half duplex
Encapsulation	DIXv2 (transmit), IEEE 802.3 and DIXv2 (receive)
Ethernet connectors	RJ-45
<b>Routing</b>	
Routing protocols	RIPv1, RIPv2, and static routes
Other	NAPT, IGMP proxy, DHCP server, DHCP relay, DNS relay, PPTP local tunneling
Class of Service	Weighted fair queueing

<b>Features</b>	
<b>Bridging</b>	
Bridging	Self-learning bridge, bridges between all interfaces. Possibility to disable bridging between WAN interfaces.
MAC table	1024 entries
Class of Service	Weighted fair queueing
<b>Command line interface (CLI) for local management</b>	
Physical layer	Electrically RS-232, TxD, RxD and GND signals
Data format	Asynchronous, 8+no parity
Bit rate	9600 bps
Flow control	None
CLI connector	RJ-45
<b>Dedicated ATM management channel</b>	
Service categories	UBR
Encapsulations	RFC2684 ETH-LLC, RFC2684 IP-LLC, RFC2364 PPP-VC
IP addressing	Statically configured Through IPCP when PPP over ATM is used
Routing	Static routes RIPv1, RIPv2
Management protocols	Telnet/TCP/IP for command line interface, TFTP/UDP/IP for software and configuration download, HTTP/web server
<b>Management through payload</b>	
Management protocols	Telnet/TCP/IP for command line interface, TFTP/UDP/IP for software and configuration download, HTTP/web server
<b>Indicator lights</b>	
DSL	ADSL line status
ETH-1, ETH-2, ETH-3, ETH-4	Ethernet activity and status
COL	Ethernet collision
STA	M1122 startup error
PWR	Power on

## A.1 Mechanical construction and power supply

M1122 is a stand-alone device which can also be wall-mounted.

<b>Mechanical construction</b>	
Width	225 mm
Height	65 mm
Depth	230 mm
Weight	1 kg

**Table A-1** Mechanical construction

M1122 has an in-built power supply. The characteristics of the mains connection are presented in Table A-2.

<b>Mains connection</b>	
Voltage	100 ... 240 VAC
Frequency	45 ... 65 Hz
Power consumption	8 W

**Table A-2** Mains connection

## A.2 Ambient conditions, EMC and safety

### Ambient conditions

Operating temperature range 5 to 45°C

Humidity 10% to 90%, non-condensing

### EMC

M1122 complies with the following specifications provided that the device is connected to an earthed socket outlet:

Emission EN55022: 1998 class B

Immunity EN55024: 1998

EMC EN300386-2: 1997

Overvoltage ITU-T K.21

**Safety**

Safety EN60950

---

## Glossary

### Abbreviations

<b>ADSL</b>	Asymmetric digital subscriber line
<b>ATM</b>	Asynchronous transfer mode
<b>CLI</b>	Command line interface
<b>COL</b>	Collision
<b>DMT</b>	Discrete multitone
<b>DSL</b>	Digital subscriber line
<b>DSLAM</b>	Digital Subscriber Line Access Multiplexer
<b>EMC</b>	Electromagnetic compatibility
<b>ETH</b>	Ethernet
<b>IP</b>	Internet protocol
<b>ISP</b>	Internet service provider
<b>L2TP</b>	Layer 2 tunneling protocol
<b>LAN</b>	Local area network
<b>LLC</b>	Logical link control
<b>MAC</b>	Media access control
<b>PC</b>	Personal computer
<b>POTS</b>	Plain old telephone system
<b>PPP</b>	Point-to-point protocol
<b>PPTP</b>	Point-to-point tunneling protocol



<b>PWR</b>	Power
<b>RAN</b>	Remote access node
<b>RFC</b>	Request for comments
<b>STA</b>	Status
<b>TCP</b>	Transmission control protocol
<b>UBR</b>	Unspecified bit rate
<b>VCC</b>	Virtual channel connection
<b>VCI</b>	Virtual channel identifier
<b>VPI</b>	Virtual path identifier
<b>WWW</b>	World Wide Web

## Terms

### 10Base-T

10 Mbit/s Ethernet specification using two pairs of twisted cabling. 10Base-T is a part of the IEEE 802.3 specification.

### ATM access network

An access network where traffic from the subscribers is multiplexed and forwarded using ATM technology.

### bridge

A device that connects two or more physical networks and forwards packets between them. Bridges can usually be made to filter packets, that is, to forward only certain traffic.

### command line interface

Character-based man-machine interface where a command line ending with <CR> character is used to configure a device. The device interprets the command and returns a character-based response.

## **Digital Subscriber Line Access Multiplexer**

A network element which multiplexes the traffic coming from the high-speed subscriber lines and forwards this traffic to the ATM network.

## **encapsulation**

Wrapping of data in a protocol header.

## **Ethernet**

LAN specification IEEE 802.3.

## **host**

Computer system on a network.

## **IP network**

Data communications network based on the Internet Protocol.

## **low-pass filter**

Passive filter used for separating the telephone signal from data signals in the digital subscriber line.

## **MAC address**

Ethernet address.

## **multiplexer**

A device where several logical connections are combined into one physical connection.

## **POTS filter**

A device used for separating the telephone signal from data signals in the digital subscriber line.

### **remote access node**

RAN accepts a high concentration of data traffic from many DSLAMs. It grooms the traffic to reduce the heavy processing load for backbone routers which can limit the scalability of high-speed networks. RAN receives cell- or frame-based end user traffic from the DSLAM and sends the aggregated IP traffic to ISP backbone routers.

### **serial console connection**

Serial connection (CLI) on the back panel of M5122. It is used for configuring M5122 locally.

### **telecommuter**

A person who works at home with data communications to the central office.

### **virtual channel**

A communications channel which provides for the sequential unidirectional transport of ATM cells.

### **virtual channel connection**

A concatenation of virtual channel links that extends between the points where the ATM service users access the ATM layer.

### **virtual path**

A unidirectional logical association of virtual channels.

### **web browser**

A software that is used to browse the World Wide Web.