



MODEL W1709 20" WIDE BELT SANDER



INSTRUCTION MANUAL

Phone: 1-360-734-3482 • On-Line Technical Support: tech-support@shopfox.biz

COPYRIGHT © SEPTEMBER, 2003 BY WOODSTOCK INTERNATIONAL, INC.
WARNING: NO PORTION OF THIS MANUAL MAY BE REPRODUCED IN ANY SHAPE OR FORM WITHOUT
THE WRITTEN APPROVAL OF WOODSTOCK INTERNATIONAL, INC.

Printed in Taiwan

WARNING

Some dust created by power sanding, sawing, grinding, drilling, and other construction activities contains chemicals known to the State of California to cause cancer, birth defects or other reproductive harm. Some examples of these chemicals are:

- Lead from lead-based paints.
- Crystalline silica from bricks, cement, and other masonry products.
- Arsenic and chromium from chemically treated lumber.

Your risk from these exposures varies, depending on how often you do this type of work. To reduce your exposure to these chemicals: work in a well ventilated area, and work with approved safety equipment, such as those dust masks that are specially designed to filter out microscopic particles.

CONTENTS

	PAGE
INTRODUCTION	2
About Your New Sander	2
Woodstock Service and Support	2
Warranty and Returns	3
Specifications	3
SAFETY	4
Standard Safety Instructions	4
Additional Safety Instructions for Sanders	6
Avoiding Potential Injuries	7
Electrical Requirements	8
220V Operation	8
Extension Cords	8
Grounding	8
ASSEMBLY	9
Unpacking	9
Box Contents	9
Shop Preparation	10
Cleaning Machine	10
Air Hose Installation	11
Sanding Belt installation	11
Shipping Plug	12
Dust Collection	12
ADJUSTMENTS	13
General Information	13
Photo-Electric Eye	13
Belt Tracking	14
Belt Oscillation Speed	15
Belt Tracking Safety Switch	16
Belt Tension Safety Switch	16
Pressure Rollers	17
V-Belt Tension	18
Feed Belt Tension and Tracking	19
Table Stop Switches	20
OPERATIONS	21
Control Panel	21
Test Run	22
Selecting Sandpaper	22
Setting Feed Speed	23
Using the Load Meter	23
Emergency Stop	24
Keypad and Display	24
Calibrating the Table	24
Basic Sanding	25
MAINTENANCE	26
General	26
Lubrication	26
Cleaning Belts	27
Servicing Separators	27
Servicing Brake	28
Changing V-Belts	29
Troubleshooting	30
Wiring Diagrams	31
PARTS	31
Parts Breakdown and Parts Lists	34
Accessories	46



INTRODUCTION

About Your New Sander

Your new **SHOP FOX®** Sander has been specially designed to provide many years of trouble-free service. Close attention to detail, ruggedly built parts and a rigid quality control program assure safe and reliable operation.

This compact wide-belt sander has digital controls and readout for setting your sanding depth automatically. You can easily and very accurately sand flat boards up to 20" wide resulting in a very smooth and flat finish. Your sander has independent motor controls, an emergency safety shut off bar, a built-in air regulator and filter, an emergency disc brake and a motorized table elevation control. Other great features that you will enjoy is the adjustable photo-electric belt oscillation system, the sanding load meter, and a quick-change belt system with automatic belt tensioning.

Woodstock International, Inc. is committed to customer satisfaction in providing this manual. It is our intent to make sure all the information necessary for safety, ease of assembly, practical use and durability of this product be included.

If you need the latest edition of this manual, you can download it from <http://www.shopfox.biz>.
If you still have questions after reading the latest manual, or if you have comments please contact us at:

Woodstock International, Inc.
Attn: Technical Support Department
P.O. Box 2309
Bellingham, WA 98227

Woodstock Service and Support

We stand behind our machines! In the event that a defect is found, parts are missing or questions arise about your machine, please contact Woodstock International Service and Support at 1-360-734-3482 or send e-mail to: tech-support@shopfox.biz. Our knowledgeable staff will help you troubleshoot problems, send out parts or arrange warranty returns.

Warranty and Returns

Woodstock International, Inc. warrants all **SHOP FOX®** machinery to be free of defects from workmanship and materials for a period of 2 years from the date of original purchase by the original owner. This warranty does not apply to defects due directly or indirectly to misuse, abuse, negligence or accidents, lack of maintenance, or to repairs or alterations made or specifically authorized by anyone other than Woodstock International, Inc.

Woodstock International, Inc. will repair or replace, at its expense and at its option, the **SHOP FOX®** machine or machine part which in normal use has proven to be defective, provided that the original owner returns the product prepaid to the **SHOP FOX®** factory service center or authorized repair facility designated by our Bellingham, WA office, with proof of their purchase of the product within 2 years, and provides Woodstock International, Inc. reasonable opportunity to verify the alleged defect through inspection. If it is determined there is no defect, or that the defect resulted from causes not within the scope of Woodstock International Inc.'s warranty, then the original owner must bear the cost of storing and returning the product.

This is Woodstock International, Inc.'s sole written warranty and any and all warranties that may be implied by law, including any merchantability or fitness, for any particular purpose, are hereby limited to the duration of this written warranty. We do not warrant that **SHOP FOX®** machinery complies with the provisions of any law or acts. In no event shall Woodstock International, Inc.'s liability under this warranty exceed the purchase price paid for the product, and any legal actions brought against Woodstock International, Inc. shall be tried in the State of Washington, County of Whatcom. We shall in no event be liable for death, injuries to persons or property or for incidental, contingent, special or consequential damages arising from the use of our products.

Every effort has been made to ensure that all **SHOP FOX®** machinery meets high quality and durability standards. We reserve the right to change specifications at any time because of our commitment to continuously improve the quality of our products.

Specifications

Sanding Motor	7 ¹ / ₂ HP, 40 Amp, 220V, Single-Phase
Sanding Motor Speed	1,725 RPM
Feed Motor	1 ¹ / ₂ HP, 3.8 Amp, 220V, Single-Phase
Feed Motor Speed	1,725 RPM
Elevation Motor	1 ¹ / ₃ HP, 3Amp, 220V, Single-Phase
Elevation Motor Speed	1,725 RPM
Drum Speed.....	3,550 FPM
Drum Diameter	7 ¹³ / ₁₆ "
Feed Rates	16.4, 23, and 32.8 FPM
Sanding Belt Size	20 ¹ / ₂ " x 48"
Total Amps (All motors under maximum load)	47 Amps
Maximum Sanding Width	20"
Maximum Sanding Thickness	6"
Minimum Stock Length	9"
Minimum Stock Thickness	1 ¹ / ₈ "
Footprint	31 ¹ / ₄ " wide x 16 ¹ / ₂ " deep
Height (With dust port installed)	60 ¹ / ₄ "
Operating Air Pressure	57 PSI
Dust Port	4"
Machine Weight	961 lbs

SAFETY FIRST!

**READ MANUAL BEFORE OPERATING MACHINE.
FAILURE TO FOLLOW INSTRUCTIONS BELOW WILL
RESULT IN PERSONAL INJURY.**



DANGER Indicates an imminently hazardous situation which, if not avoided, WILL result in death or serious injury.



WARNING Indicates a potentially hazardous situation which, if not avoided, COULD result in death or serious injury.



CAUTION Indicates a potentially hazardous situation which, if not avoided, MAY result in minor or moderate injury, MAY result in property damage.

NOTICE

This symbol is used to alert the user to useful information about proper operation of the equipment.

Standard Safety Instructions

1. **Thoroughly read the instruction manual before operating your machine.** Learn the applications, limitations and potential hazards of this machine. Keep manual in a safe, convenient place for future reference. Make sure any other operators have read and understand the manual as well.
2. **Keep work area clean and well lighted.** Clutter and inadequate lighting invite potential hazards.
3. **Ground all tools.** If a machine is equipped with a three-prong plug, it must be plugged into a three-hole grounded electrical outlet or grounded extension cord. If using an adapter to aid in accommodating a two-hole receptacle, ground using a screw to a known ground.
4. **Wear eye protection at all times.** Use safety glasses with side shields or safety goggles that meet the national safety standards, while operating this machine.
5. **Avoid dangerous environments.** Do not operate this machine in wet or open flame environments. Airborne dust particles could cause an explosion and severe fire hazard.
6. **Ensure all guards are securely in place and in working condition.**
7. **Make sure switch is in the "OFF" position before connecting power to machine.**
8. **Keep work area clean, free of clutter, grease, etc.**
9. **Keep children and visitors away.** Visitors should be kept at a safe distance away while operating unit.
10. **Childproof workshop with padlocks, master switches or by removing starter keys.**
11. **Disconnect machine when cleaning, adjusting or servicing.**

12. **Do not force the machine.** The machine will do a safer and better job if it does the work.
13. **Use the correct tool.** Do not force the tool or attachment to do a job for which it was not designed.
14. **Wear proper apparel.** Do not wear loose clothing, gloves, jewelry, keep long hair tied up, etc.
15. **Remove adjusting keys and wrenches.** Before turning the machine on, make a habit of checking that all adjusting keys and wrenches have been removed before turning the machine *ON*.
16. **DO NOT use extension cord.** Due to the high-amperage draw of this industrial machine, we do not recommend using an extension cord. If you use an extension cord with an undersized gauge or one that is too long, excessive heat will be generated within the circuit increasing the chance of a fire or damage to the circuit.
17. **Keep stable footing and balance** at all times.
18. **Do not leave machine unattended.** Wait until it comes to a complete stop before leaving the area.
19. **Perform machine maintenance and care.** Follow lubrication and accessory attachment instructions in the manual.
20. **Keep machine away from open flame.** Operating machines near pilot lights and/or open flames creates a high risk if dust is dispersed in the area. Dust particles and an ignition source may cause an explosion. Do not operate the machine in high-risk areas, including but not limited to, those mentioned above.
21. **If at any time you are experiencing** difficulties performing the intended operation, stop using the machine! Then contact our Service Department or ask a qualified expert how the operation should be performed.
22. **Habits—good and bad—are hard to break.** Develop good habits in your shop and safety will become second-nature to you.

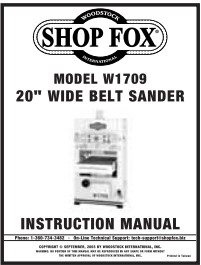

Additional Safety Instructions for Sanders

 <p>SHOP FOX MODEL W1709 20" WIDE BELT SANDER INSTRUCTION MANUAL</p>	<p>⚠ WARNING READ and understand this entire instruction manual before using this machine. Serious personal injury may occur if safety and operational information is not understood and followed. DO NOT risk your safety by not reading!</p>
---	--

<p>⚠ CAUTION USE this and other machinery with caution and respect, and always consider safety first, as it applies to your individual working conditions. Remember, no list of safety guidelines can be complete, and every shop environment is different. Failure to follow guidelines can result in serious personal injury, damage to equipment and/or poor work results.</p>
--

1. **Always wear a dust mask.** Sanding operations create large amounts of fine dust. Some types of dust may cause allergic reactions or respiratory problems. In addition to wearing a dust mask, always use a dust collector and overhead air filter for maximum protection.
2. **Do not allow your fingers to get pinched between the board and the conveyor belt during feeding.** The grip of the conveyor belt may pull the operator's hand into the machine and cause serious injury or death. Similarly, do not place hands near the sanding belts during operation.
3. **Know the limits of the sander.** Do not sand stock thinner than 1/8" or shorter than 10".
4. **Never perform sanding operations with the access doors open.**
5. **Always inspect stock for staples, nails, dirt or other foreign objects before sanding.** These items may cause damage to your sander or may even be thrown at a high rate of speed from the sander at the operator.
6. **Never allow anyone to stand directly in front or behind the path of the stock as it is being fed through the sander.** The stock may be ejected at a high rate of speed and could cause serious injury to the operator or bystanders.
7. **Treat your sander with respect.** Do not force stock into the sander during operation or overload the sanding drums beyond reasonable limits. Also, only sand natural wood fiber through your sander. Other materials may damage your machine and open the possibility for operator injury. Keep the internal components clean and lubricated to ensure that the sander can perform the way it was intended.
8. **Never operate the sander without a working dust collection system.** The sander is designed to properly do its job only when wood dust is being evacuated. The buildup of too much wood dust in the internal components will cause performance problems and may increase the likelihood of operator injury.
9. **Wear the proper clothing during all operation and adjustments.** Loose clothing or long hair creates the potential for operator injury because they can easily be caught in the moving parts of the machine. Roll up loose sleeves, tie back long hair and take any other necessary steps to reduce this hazard.

Avoiding Potential Injuries



Figure 1. Correct body and hand positioning.



Figure 2. DO NOT operate without safety glasses/respirator!



Figure 3. DO NOT stand behind workpiece!



Figure 4. DO NOT operate with side door open!



Figure 5. DO NOT allow hand to get pinched in belt!

Electrical Requirements

220V Operation

The SHOP FOX® Model W1709 has a 7½ HP, 220V single-phase sanding motor, a ½ HP, 220V feed motor, and a ⅓ HP table lift motor.

Use a 50 amp circuit breaker and a circuit that has wiring rated to handle this amperage draw. Keep in mind that a circuit being used by other machines or tools at the same time will add to the total load being applied. Add up the load ratings of all machines on the circuit. If this number exceeds the rating of the circuit breaker or wiring, use a different circuit.

Extension Cords

DO NOT use an extension cord for 220V high amperage industrial shop machines. We recommend following all local electrical codes and using a direct hard wired power supply that is protected by a circuit breaker and is equipped with a kill switch lever that can be locked in the **OFF** position.

Grounding

This machine must be grounded! Hardwire this machine into a power supply circuit that contains a ground circuit. If you have any questions about correct electrical installation, contact a qualified electrician for assistance to make sure all connections are safe and adhere to your local electrical codes.

	<p>⚠ WARNING TURN-OFF and LOCK your master power switch so no power is available to the sander before connecting electrical wires! If you ignore this warning serious electrical shock may occur causing injury or death!</p>
--	---

	<p>⚠ WARNING Any electrical outlet and circuit that you plug your machine into must be grounded. Never remove the grounding pin from any plug, and always make sure all wiring to the machine is grounded before operating. Serious injury may occur if this warning is ignored!</p>
--	--

<p>⚠ CAUTION DO NOT replace the circuit breaker with one rated at a higher amperage or damage to the circuit may occur.</p>
--

SAFETY

ASSEMBLY

Unpacking

The Model W1709 has been carefully packaged for safe transporting. If you notice the machine has been damaged, please contact Woodstock International Service and Support at 1-360-734-3482 or send e-mail to: tech-support@shopfox.biz.

Box Contents

The following is a description of the components shipped with the **SHOP FOX®** W1709. Lay the components out in a similar fashion to those in **Figure 6**. This will help in identification before beginning assembly. Should any part be missing, examine the packaging carefully. If any parts are missing, find the part number in the back of this manual and call Woodstock International, Inc. at 360-734-3482 or e-mail: tech-support@shopfox.biz.

Item	Qty.
Combination Wrench 8 x 10mm	(1)
Combination Wrench 12 x 14mm	(1)
Combination Wrench 17 x 10mm	(1)
Phillips Screwdriver	(1)
Standard Screwdriver	(1)
Hex Wrench Set (10-Piece 1.5-10mm)	(1)
Square-Key Door Handle	(2)
Sanding Belt	(2)
4-Amp Fuse Bag (Located Inside of Power Box) (2)	
Sander (Not Shown)	(1)
Tool Box (Not Shown)	(1)
Dust Port (Not Shown)	(1)
Dust Port Adapter (Not Shown)	(1)
Ceramic Wear Rods (Not Shown)	(2)

⚠ WARNING
READ and understand this entire instruction manual before performing any operations with your machine. Personal injury may occur if safety and operational information is not understood and followed.

⚠ WARNING
The Model W1709 is a heavy machine at 1,870 lbs. Use power or hydraulic equipment to avoid serious personal injury or death.



Figure 6. Parts shipped with the sander.

ASSEMBLY

Shop Preparation

- Floor Load and Balance:** Your sander represents a large weight load in a small footprint. Most commercial floors are suitable for the sander. Some residential floors may require additional bracing to support both machine and operator. Make sure the sander operates on a level surface by placing a level gauge on the conveyor table and using a wrench to adjust the feet until the machine is level.
- Working Clearances:** Consider existing and anticipated needs, size of material to be processed through each machine, and space for auxiliary stands, work tables or other machinery when establishing a location for your sander.
- Lighting and Outlets:** Lighting should be bright enough to eliminate shadows and prevent eye strain. Electrical circuits should be dedicated or large enough to handle amperage requirements. Outlets should be located near each machine so any power or extension cords are clear of high-traffic areas. Observe local electrical codes for proper installation of new lighting, outlets, or circuits.

	<p>⚠ CAUTION</p> <p>MAKE SURE that all entrances to your shop are locked or that machines are equipped with safety lock-out devices to protect curious children or visitors from serious injury. Never allow unsupervised people in your shop who have not been fully trained!</p>
---	---



Cleaning Machine

The upper roller of the Model W1709 is coated with a waxy grease that protects it from corrosion during shipment. **This coating must be removed before using your sander.**

Clean this grease off with a solvent cleaner or citrus-based degreaser. Do not use chlorine-based solvents—if you happen to splash some onto a painted surface, you will ruin the finish.

	<p>⚠ WARNING</p> <p>NEVER use flammables such as gas or other petroleum-based solvents to clean your machine. These products have low flash points and present the risk of explosion and severe personal injury!</p>
--	---

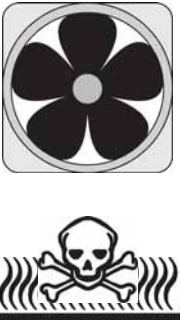
	<p>⚠ WARNING</p> <p>NEVER smoke when using solvents. Smoking may cause explosion or risk of fire when exposed to these products!</p>
--	---

	<p>⚠ CAUTION</p> <p>WORK in a well ventilated area when using solvents, and keep away from any potential ignition sources (pilot lights). Most solvents used to clean machinery are toxic when inhaled or ingested. When using these products, Always dispose of any waste rags in a sealed container to make sure they do not cause fire or environmental hazards.</p>
	

Air Hose Installation

Push your air supply hose on to the air pressure regulator inlet fitting, and clamp it in place with a hose clamp as shown in **Figure 7**. If you prefer, you can replace the included air nozzle with a $\frac{3}{8}$ " male quick connect air coupling.

When the air hose is installed, pull up and rotate the regulator air pressure knob until the gauge reads 57 PSI then push down. **DO NOT** attempt to regulate the air pressure with the ON/OFF air supply lever. This control only shuts off air pressure to the machine.

NOTICE

To achieve maximum life of the air system o-rings, gaskets, and components, keep the air pressure shut off when not using the sander, and **DO NOT** exceed 75 PSI.



Figure 7. Air hose attached to regulator.

Sanding Belt Installation

Before installing belt, clean the protective grease from the upper metal sanding belt roller as per the "Cleaning Machine" instructions.

To install the sanding belt, do these steps:

1. **TURN-OFF** and **LOCK** your master power switch, but keep the air pressure going into the machine.
2. Turn and remove the lever and support spacer. See **Figure 8**.
3. Install the sanding belt with the arrows pointing in the direction of drum rotation and center the belt on the rollers. See **Figure 9**.
4. Reinstall the support spacer and lever.
5. Turn the belt tension knob to the 12:00 position and the belt will automatically tighten to the correct tension. At 9:00 the belt will have no tension.



Figure 8. Lever removal/installation.

NOTICE

TENSION the sanding belt before starting the sander, and **DE-TENSION** the belt when sander is not in use, or you will damage the belt.

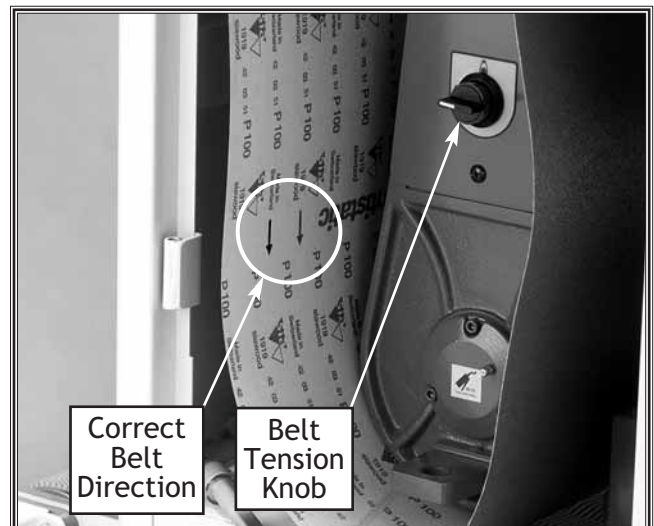



Figure 9. Installing sanding belt.

Dust Collection

The Model W1709 features a dust port and an adapter located on top of the machine as shown in **Figures 10** and **11**. Before performing any sanding operation, attach the dust port to a 2HP or better dust collector, which can draw at least 1,200 CFMs, or dust buildup will hinder the performance of your sander.

Even with a sufficient dust collection system, a fine layer of dust may still be present on your stock as it comes out of the sander. This residual dust is a normal condition.

ASSEMBLY

	<p>⚠ CAUTION</p> <p>DO NOT operate this machine without an adequate dust collection system. This machine creates substantial amounts of wood dust while in operation. Failure to use a dust collection system can result in short and long-term respiratory illness.</p>
--	---

	<p>⚠ CAUTION</p> <p>ALWAYS wear your respirator in addition to using a dust collector. This machine produces sawdust that may cause allergic reactions or respiratory problems.</p>
---	--

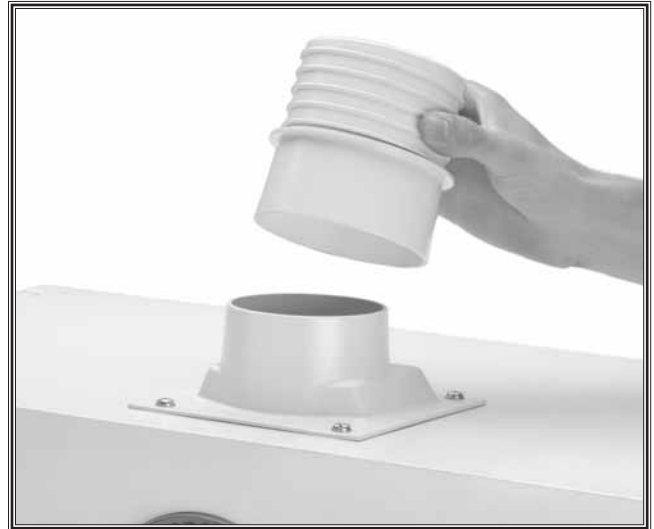

Figure 10. Dust collection adapters.



Figure 11. Dust collection hose attached to dust port.

ADJUSTMENTS

General Information

The adjustments in this section have been factory set and generally do not need to be performed when you first receive your sander. However, before operating your sander become familiar with these adjustments, as they will help you achieve the sanding results you want.



Photo-Electric Eye

The photo-electric eye senses when the belt oscillates to the right and blocks the beam to and from the reflector. See **Figures 12 and 13**. As soon as the sanding belt obstructs the beam, a piston changes the direction of belt movement to the left. Should the adjustment of the photo-electric eye become skewed, you can readjust the eye.

To adjust the photo-electric eye, do these steps:

1. **TURN-OFF** and **LOCK** the master power switch so no power can go to your sander, but keep the air pressure going into the machine.
2. Make sure the air regulator is adjusted so that system air pressure is 57 PSI.
3. Open both upper access doors on the sander.
4. Loosen the sanding belt tension and slide the belt so the belt is positioned in the middle of the rollers.
5. Apply power to the sander and push the emergency stop button in so the sander cannot start.
6. Loosen the photo-electric eye mounting bolt. See **Figure 12**.
7. Position the mount so the photo-electric-eye beam is barely obstructed by the edge of the belt, pointing at the reflector, and you hear the electric solenoid click and the piston pushes the pushrod outward. See **Figures 12 and 13**.
8. Tighten the mounting bolt.
9. Start the sander, and check for correct belt positioning and oscillation.
10. Repeat **steps 1** through **9** until the photo-electric eye positioning is correct.

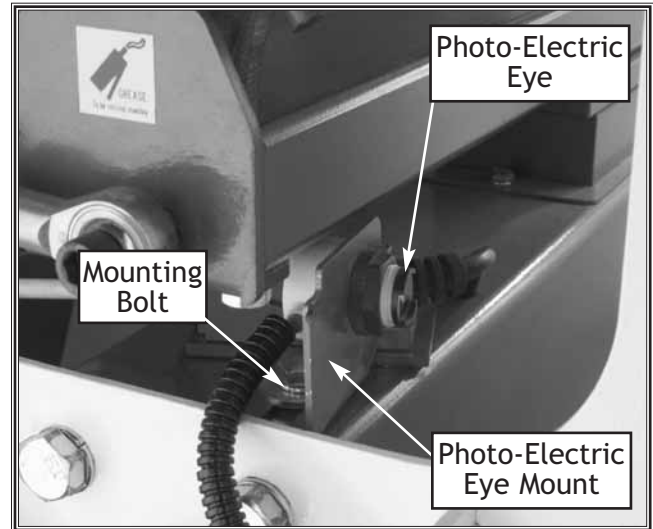

Figure 12. Photo-electric-eye assembly.

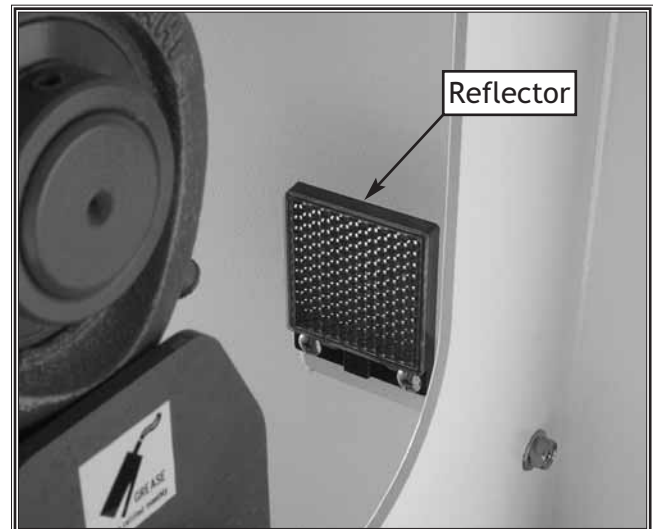

Figure 13. Photo-electric-eye reflector.

Belt Tracking

The belt tracking is adjusted by lengthening or shortening an air cylinder pushrod (Figure 14). This adjustment is responsible for keeping the belt in “same-speed” left-to-right motion during sanding. Your goal is to adjust the pushrod length until the belt left-and-right movement takes approximately the same amount of time.

⚠ CAUTION

KEEP your hands clear of the sanding belt when making these adjustments!

To adjust the belt tracking, do these steps:

1. Make sure the air flow is set to 57 PSI at the regulator.
2. Put on safety glasses, tie back all loose clothing, remove jewelry, pull back sleeves, and tie back long hair so it will not get caught by the sanding belt.
3. Turn the sander *ON*.
4. Observe the left-to-right motion of the belt as it moves along the drum while looking from the front of the sander.
 - If the belt tracks faster to the right, but is slow to track back to the left, loosen the jam nut and rotate the pushrod to lengthen the rod until the tracking is correct. See Figure 14.
 - If the belt tracks faster to the left, but is slow to track back to the right, loosen the jam nut and rotate the pushrod to shorten the rod until the tracking is correct. See Figure 14.
5. Make sure the belt tracks left and right at approximately the same speed.
6. Keep the sander running, and now complete the **Belt Oscillation Speed** adjustment as outlined on page 15.



⚠ WARNING
KEEP loose clothing and long hair secured and away from moving parts.

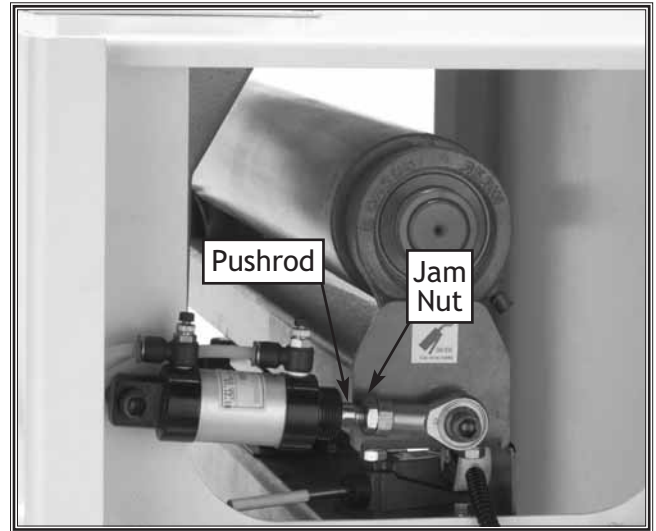

Figure 14. Belt tracking adjustment location.

Belt Oscillation Speed

For normal operations, the oscillation speed should be set so that it takes approximately one second to move each direction of travel, or a total of two seconds to move both directions.

However, you can experiment with different speeds to see how the results may affect your finished product. Often, you may find that certain speeds yield better results for different varieties of stock and the feed rates chosen.

⚠ CAUTION

KEEP your hands clear of the sanding belt when making these adjustments!

To set the belt oscillation speed, do these steps:

1. Complete the **Sanding Belt Tracking** adjustment on **page 14**.
2. Put on safety glasses, tie back all loose clothing, remove jewelry, pull back sleeves, and tie back long hair so it will not get caught by the sanding belt.
3. If you have not already done so, turn the sander **ON**.
4. Looking from the front of the sander, observe the left-to-right motion of the belt as it moves along the drum while.
5. Loosen the needle valve jam nuts. See **Figure 15**.
6. With your fingertips, turn both needle valves counter-clockwise to increase the oscillations, or turn clockwise to decrease oscillations.
7. When the belt oscillation is at the rate you need, hold the needle valve, and with your fingertips tighten the needle valve jam nuts.
8. Observe belt tracking and oscillation, and complete the **Sanding Belt Tracking** adjustment on **page 14** if tracking is slightly out of adjustment.



⚠ WARNING
KEEP loose clothing and long hair secured and away from moving parts.

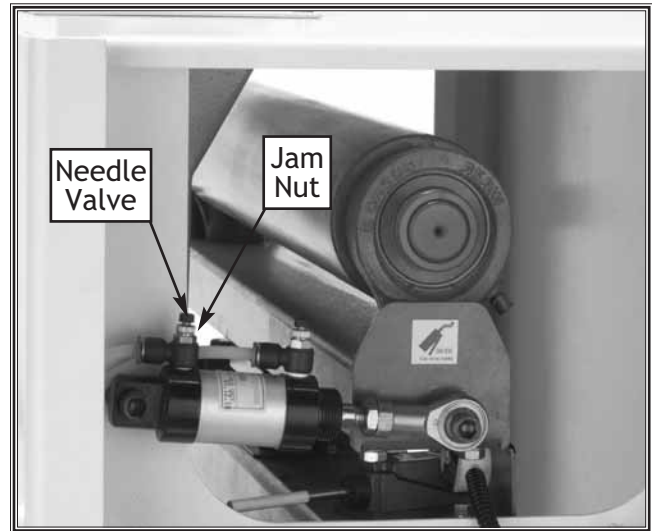

Figure 15. Belt oscillation adjustment.

Belt Tracking Safety Switch

Belt tracking safety switches are placed on both sides of the belt to act as emergency machine stops if the belt travels too far to one side during oscillation. See **Figure 16**.

To adjust the belt tracking safety switches, do these steps:

1. **TURN-OFF** and **LOCK** the master power switch so no power can go to your sander!
2. Make sure the belt tracking and oscillation is adjusted.
3. Release the belt tension, center the sanding belt on the top roller, then re-tension the belt.
4. Measure the distance from the edge of the sanding belt to the ceramic rod protruding from the switch.
5. Loosen the adjustment bolt shown in **Figure 16** and move the switch so the belt and the ceramic rod have approximately $\frac{1}{2}$ " clearance from each other.
6. Tighten the bolt and repeat the adjustment with the other side if necessary.
7. Start the sander and make sure it is working properly.

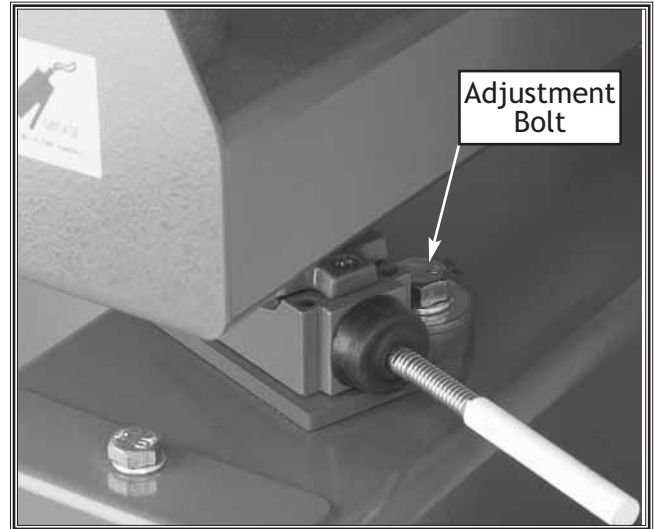

Figure 16. Tracking safety switch and adjustment bolt.

Pressure Rollers

The pressure rollers are factory set so they are parallel with each other, parallel with the sanding drum, and parallel with the surface of the conveyor table. Additionally, the front pressure rollers must be set 0.040" below the sanding drum, and the rear rollers at 0.020" below the sanding drum. When these settings are achieved, the pressure-roller spring tension will be correct.

To adjust the pressure rollers, do these steps:

1. **TURN-OFF** and **LOCK** the master power switch so no power can go to your sander!
2. Make two gauge boards that are 24" long and uniform in thickness.
3. Connect the air pressure and set it to 57 PSI.
4. Install the sanding belt and turn the belt tensioning knob to the 12:00 position to tension the belt. See **Figure 17**.
5. Position each board on each side of the conveyor belt and directly below the front and back pressure rollers. See **Figure 18**.
6. Loosen the adjustment jam nuts and raise the pressure rollers above the sanding belt roller with the adjustment bolts shown in **Figure 17**.
7. Raise the table up until the boards barely touch the sanding belt.
8. Turn the table-height handwheel counter-clockwise one complete turn to lower the table approximately 0.020".
9. Lower the rear pressure rollers so that both ends barely touch the gauge boards. The rear pressure rollers are now set at 0.020" below the sanding drum.
10. Turn the table-height handwheel counter-clockwise again one complete turn, which lowers the table an additional 0.020".
11. Lower the front pressure rollers so that both ends just touch the boards. The front pressure rollers are now set at 0.040" below the sanding drum.
12. Tighten the adjustment jam nuts.

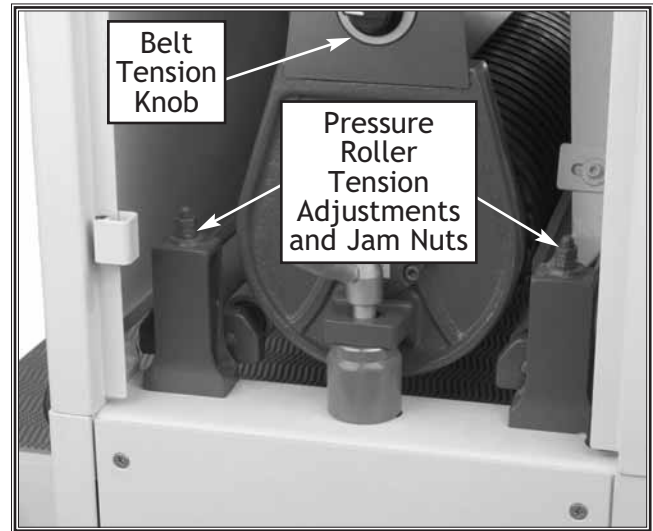

Figure 17. Belt and pressure roller adjustments.



Figure 18. Gauge boards placed under pressure rollers as a gauge.

V-Belt Tension

The sanding motor V-belts that drive the sanding rollers (Figure 19) and the table lift motor that adjust table height (Figure 20), must be tensioned properly for best performance. Only replace the belt if it becomes frayed, cracked, or glazed. If one belt is bad, always replace both belts as a matched set. NOTE, Both table lift and sanding motor belts are adjusted the same way.

CAUTION

KEEP the sanding drum drive belts correctly adjusted. If the belts are loose, and the emergency stop is engaged, the sanding drum pulley will slip and not immediately stop in the event of an emergency!

To tension the V-belts, do these steps:

1. **TURN-OFF** and **LOCK** the master power switch so power cannot start your sander!
2. Remove the lower cover(s) on the sander (right cover for sanding belt motor, left cover for the conveyor height motor).
3. Turn both nuts clockwise to tighten the V-belts, or turn both nuts counterclockwise to loosen the V-belts.
4. The V-belt is properly tightened when it will move no more than $\frac{3}{4}$ " in the center with moderate pressure from your thumb.

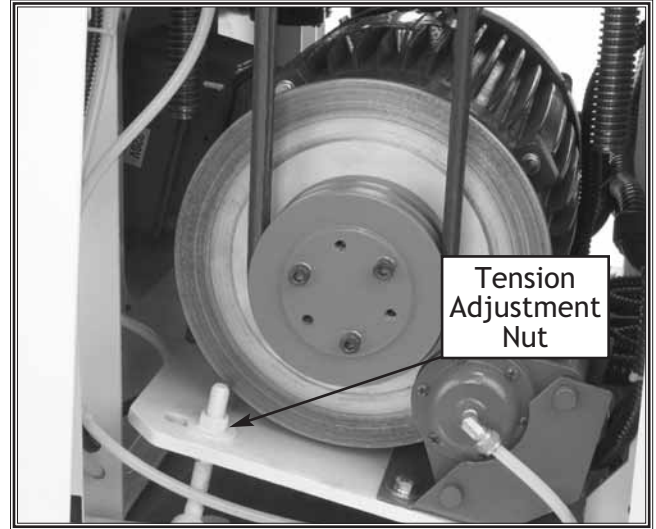

Figure 19. Sanding motor v-belt adjustment.

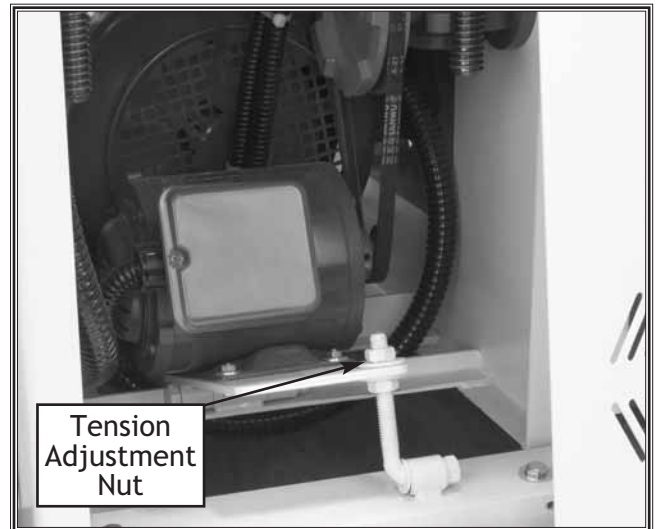

Figure 20. Table lift motor v-belt adjustment.

Feed Belt Tension and Tracking

The feed belt tension and tracking has been set at the factory; however, if at any point you notice that your feed belt is slipping or tracking off center on the rollers and loading up on the positioning wheels under the conveyor table, you must adjust the feed belt tension and tracking.

To adjust the feed belt tension and tracking, do these steps:

1. Lift and hold the emergency stop plate up and out of the way. See **Figure 21**.
2. Turn the feed belt tension and tracking bolts equal amounts from side-to-side and set the belt tension so it is snug and will not slip when sanding at a maximum load.

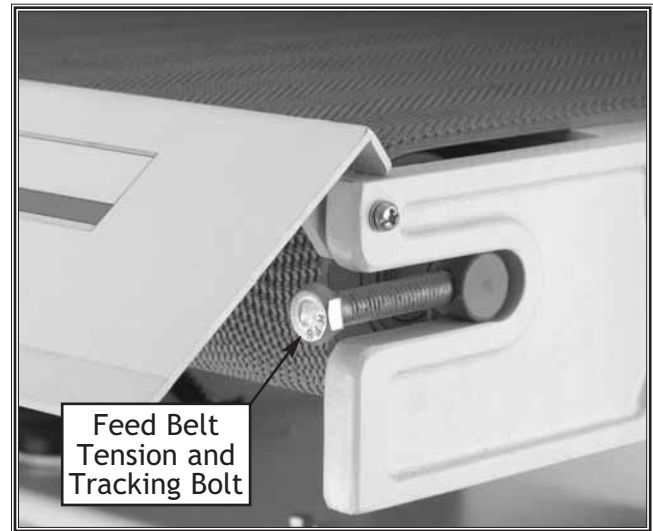

Figure 21. Feed belt tension bolt shown with the emergency brake raised.



3. Start the conveyor.
4. Turn the feed belt tension and tracking bolt to position the feed belt roller evenly on each side. See **Figure 21**.
 - If the conveyor tracks to the right, turn the right-side tension and tracking bolt clockwise in approximately $\frac{1}{4}$ turn increments.
 - If the conveyor tracks to the left, turn the left-side tension and tracking bolt clockwise in approximately $\frac{1}{4}$ turn increments.
5. Run the feed belt for at least three minutes to determine if the tracking is correct and the tension stays the same.
6. Repeat steps as required to achieve the correct tension and tracking.
7. Test emergency stop operation.

Table Stop Switches

The table stop switches prevent the table lift motor from running the table into the sanding drum and bottoming out the table lift mechanism at the end of the jack screws. Periodically adjust the table stop switches.

To adjust table stop switches, do these steps:

1. Apply air to the sander and tension the sanding belt.
2. Push the down arrow key and lower the table until you achieve 6 inches between the sanding drum and the conveyor table surface. See **Figure 22**.
3. Loosen the mounting bolt for the table-down stop switch and move the switch so the switch plunger depresses against the stop block and you hear the switch click. See **Figure 23**.
4. Re-tighten the mounting bolt.
5. Push the up arrow key and raise the table until you achieve an $\frac{1}{8}$ inch between the sanding drum and the conveyor table surface.
6. Loosen the mounting bolt for the table-up stop switch and move the switch so the switch plunger depresses against the stop block and you hear the switch click. See **Figure 23**.
7. Re-tighten the mounting bolt.
8. Use the up and down buttons and test the table operation and make sure the switches shut the table lift motor **OFF** when the table is at the minimum and maximum distance from the sanding drum.

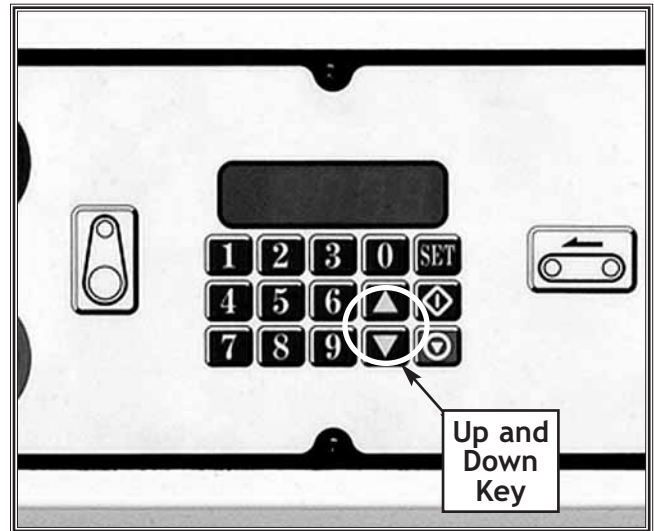

Figure 22. Key pad table-lift controls.

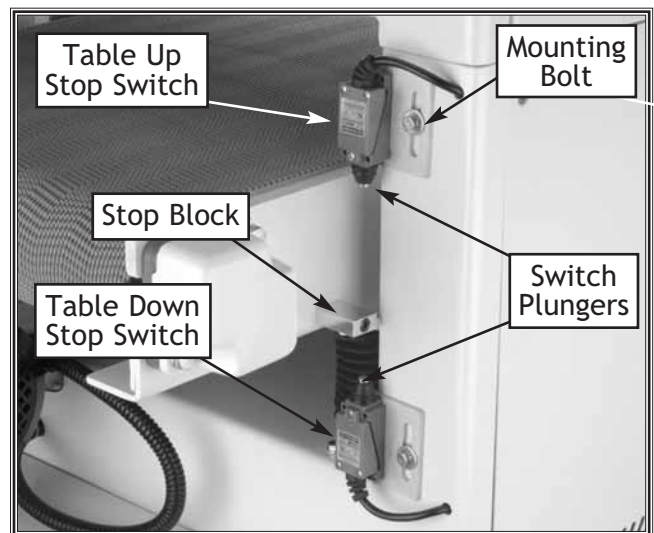

Figure 23. Table stop switch adjustment locations.

OPERATIONS

Control Panel

Below is a summary of your sander control panel and the components that it controls. Use this information to become familiar with your sander. See **Figure 24**.

- **Power Lamp:**
Indicates when machine has power to the control panel.
- **Emergency Stop Button:**
Stops all electrical power to motors in event of emergency, and stops sanding drums with an air-disc brake.
- **Sanding Belt Start and Stop Buttons:**
Cycles the sanding motor *ON* and *OFF* if the sander has air pressure and the belt is tensioned.
- **Feed Belt Start and Stop Buttons:**
Cycles the conveyor motor *ON* and *OFF* for feeding wood into the sander.
- **Table Up and Down Keys:**
Manually cycles the table lift motor to raise and lower the table.
- **Table Start and Stop Keys:**
Cycles the table lift motor in and out of the automatic raise and lower function.
- **Sanding Load Amp Meter:**
Indicates the current amp load on the sanding motor when a sanding operation is in progress.
- **Digital Readout:** Displays current sander settings.
- **Input LED:** Indicates the sander is waiting for new numerical dimension values.
- **Run LED:** Indicates the conveyor lift motor is operating.
- **Key Pad:** Allows you to input your numerical sanding specifications for automated sanding control.

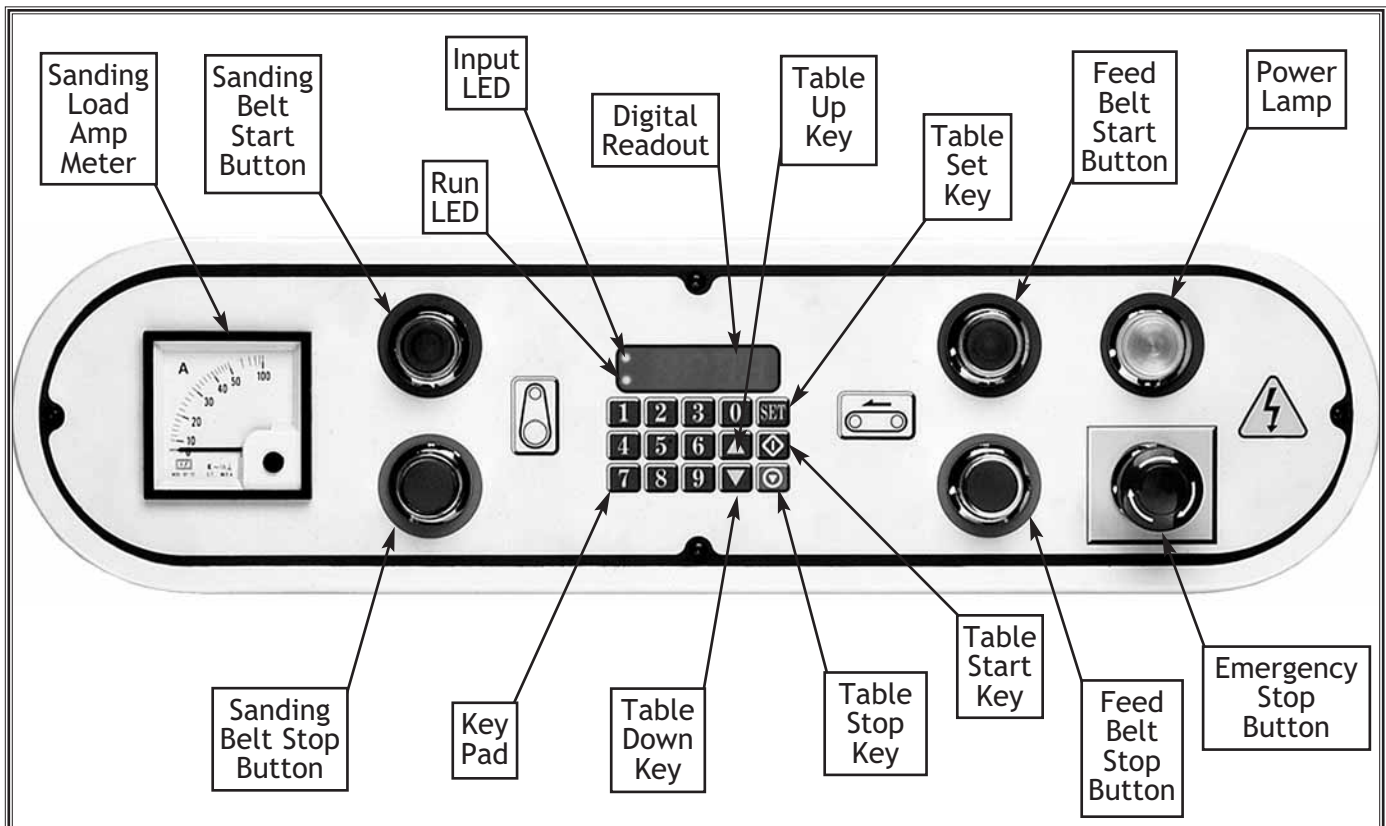

Figure 24. Control panel interface.

Test Run

Once assembly is complete, the machine is ready for a test run. The purpose of a test run is to identify any unusual noises and vibrations, as well as to confirm that the machine is performing as intended.

To complete the test run, do these steps:

1. Tie back loose clothing and hair, and wear a respirator and safety glasses.
2. Apply power to the sander and connect the supply air to the sander. Make sure the air pressure is set at 57 PSI.
3. Make sure the sanding belt is tensioned.
4. Make sure all access doors and handles are secured.
5. Start the dust collection system.
6. Turn the sander and feed belt *ON*.
7. Listen for any unusual noises. The machine should run smoothly with little or no vibrations.
 - If there are any unusual noises or vibrations, shut the machine off immediately. **TURN-OFF and LOCK the master power switch so no power can go to your sander, and disconnect the air line.**
 - Investigate the source of the noise or vibration. **DO NOT** make any adjustments to the machine while it is plugged in. The machine should not be run any further until the problems are corrected.



! WARNING
 ALWAYS wear safety glasses and a respirator during operations. Serious injury may occur if this warning is ignored!



! WARNING
 KEEP loose clothing and long hair secured and away from moving parts.



! WARNING
 ALWAYS wear hearing protection during sanding operations. Serious injury may occur if this warning is ignored!

Selecting Sandpaper

When selecting sandpaper, keep in mind that the Model W1709 accepts only 20¹/₂" W x 48" L belts. Consider the type of work, the species of wood and the stage of finishing. Use these numbers as a general guide to sandpaper type:

- 60 Grit.....Coarse
- 80-100 GritMedium
- 120-150 GritFine

For best results, do not increase grit numbers more than 50 on any successive pass.

Setting Feed Speed

The feed belt motor offers speeds of 16.4, 23, and 32.8. **Figure 24** points out the variable conveyor feed speed control knob.

To change the feed belt speed do these steps:

1. **TURN-OFF** and **LOCK** the master power switch so power cannot start your sander!
2. Remove the 6mm Allen screw in the center of the chain cover and remove the cover.
3. Use a $\frac{7}{8}$ " Allen wrench and loosen the two motor retaining bolts.
4. Pivot the motor upward and move the chain to the required set of sprockets.
5. Re-tension the motor, tighten bolts and reinstall the cover.

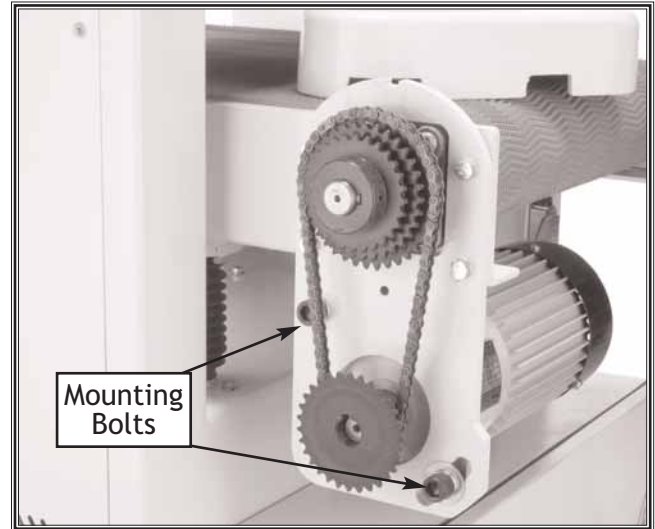

Figure 24. Changing conveyor speed.

Using the Load Meter

NOTICE

Removing too much material from the workpiece during one pass slows the motor RPM to the point where the internal start windings engage and motor damage occurs. An indication of motor overloading is failed start capacitors, which may not be covered under warranty.

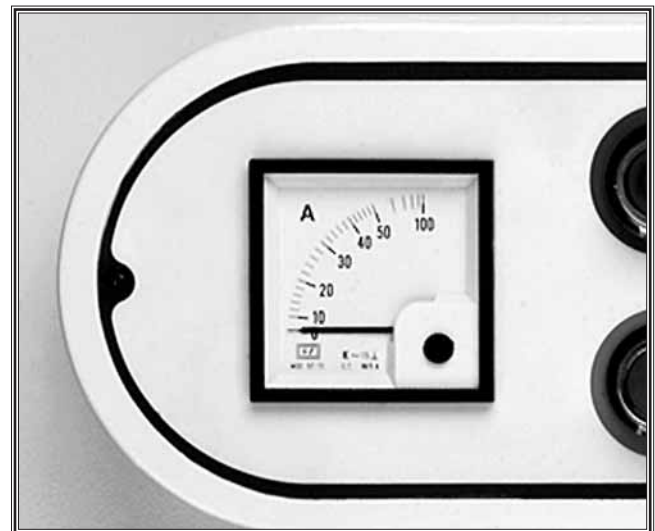

Figure 25. Load meter.

The load meter shown in **Figure 25** is an important tool for determining sanding depth while you are feeding the workpiece. The load meter displays the amperage draw of the sanding motor, which is an indicator of how deep the sanding depth is.

Use this meter to maintain consistent sanding depths. Generally, the normal depth of cut is no more than $\frac{1}{64}$ " or 0.016" for a 20" wide board.

Emergency Stop

When pushed, the emergency stop plate shown in **Figure 26** stops electricity to the motors and stops the sander quickly by using a disc brake on the drive motor.

⚠ CAUTION

KEEP the sanding drum drive belts correctly adjusted. If the belts are loose, and the emergency stop is engaged, the sanding drum pulley will slip and not immediately stop in the event of an emergency!

To apply the emergency stop, do these steps:

1. Push the bottom of the emergency stop plate as far as it will go.
2. Hold the emergency stop plate until the sander has come to a complete stop.

Keypad and Display

The conveyor table lift motor is controlled by the key pad and indicated on the digital display shown in **Figure 27**. You can push the **UP** or **DOWN** arrow keys to lift or lower the table, or you can use the automated function of auto height adjustment for your next sanding pass. All functions are controlled through the key pad and are presented on the digital display. See **Figure 27**.

Calibrating the Table

When you change the sandpaper or you notice and inconsistency with the actual sanding thickness in relationship to your digital setting, you must re-calibrate the table.

To re-calibrate your table, do these steps:

1. Insert a calibration board that is 1-1/2" thick.
2. Press the UP arrow key: so the table lifts and the sandpaper just touches the surface of the calibration board. For fine tuning the clearance, use the handwheel shown in **Figure 28** instead of the arrow keys. **DO NOT** hold or grab the handwheel when using the arrow key, as the motor is driving the handwheel in that mode of operation.



Figure 26. Emergency stop plate.

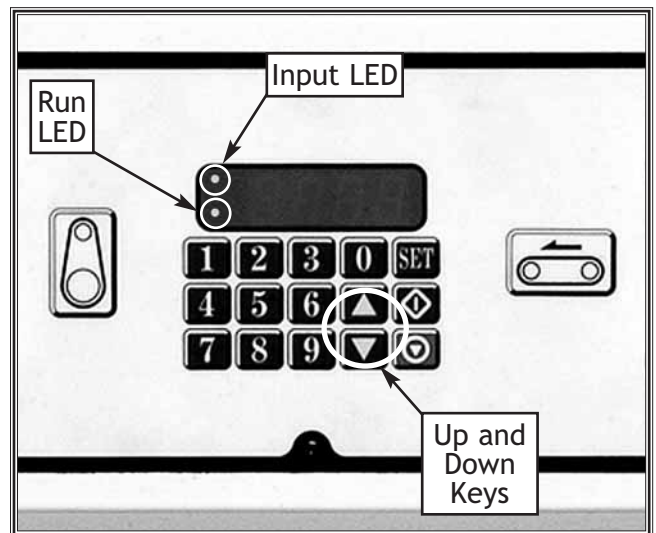

Figure 27. Digital display and key pad.



Figure 28. Table height handwheel.

3. Use the numeric key pad and enter the thickness of your calibration board (Example: 1.500 for 1-1/2" thick).
4. Press and hold the SET key for 3 seconds: The table is now calibrated.
5. Press the down arrow key:
6. Remove the calibration board.

Basic Sanding

To achieve the best sanding results experiment with conveyor feed rate, sanding depth, various grits of sandpaper, and oscillation speed.

To sand a workpiece, do these steps:

1. Make sure the table is calibrated and the needed sandpaper is installed and tensioned.
2. Turn the sander **OFF**, set the feed rate, then turn the sander **ON**.
3. Measure your workpiece and find the highest location.
4. Type in the thickness of your workpiece using the numeric key pad (Example: for a 2" thick workpiece type 2.000"), and press the table start key:

Note: the upper left corner Input Led will illuminate (See Figure 27), and the display numbers will flash when entering measurements.

5. Measure the sanding depth needed. Example: let's say you need 1/16".

Note: removing too much material can burn the workpiece, tear the paper, and give poor sanding results.

6. Convert 1/16" fraction to a 0.063" decimal measurement using the conversion table on the sander.
7. Calculate the resulting workpiece thickness (2.000" - 0.063" = 1.937"), and type the thickness (1.937") on the key pad.
8. Press the table start key: The table will raise 0.063".

Note: The lower left corner Run Led will illuminate and the display numbers will glow steady when measurements have been accepted and the table is auto-adjusting.

Note: When the correct sanding depth is achieved, the lower left corner Run Led will turn off and the final resulting workpiece thickness is displayed.

10. Start the conveyor, stand to the side as shown in Figure 29, and feed the workpiece into the sander.
11. Observe the load meter, and press the table down arrow key on the key pad to reduce the sanding depth if there is a problem.
12. Remove the workpiece from the outfeed side, which is now sanded down 1/16". You now can add a new sanding depth the same way as in steps 7 and 8 and sand again.

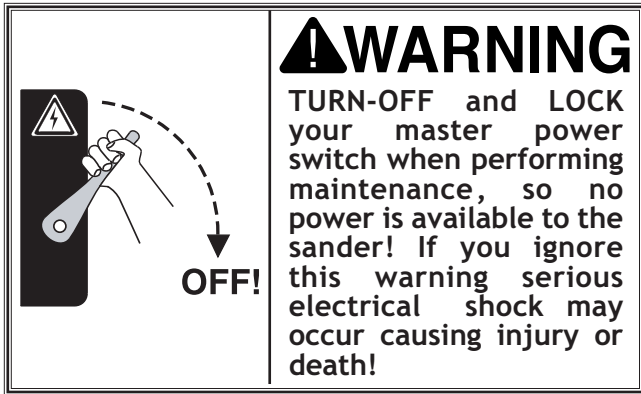

Figure 29. Operator feeding workpiece in correct body position and out of the way of potential kickback.

Quick Tip

For best results for finish sanding, feed each piece through the sander two or three times without adjusting the depth of cut. Turn the workpiece 180° and feed it through two or three more times at this same depth. As always, use your best judgement. If you no longer hear the sanding belt making contact with the workpiece on successive cuts, then no further passes are needed at that depth.

MAINTENANCE



General

Regular maintenance on your Model W1709 will ensure its optimum performance. Make a habit of inspecting your machine each time you use it. And at the end of the day remove the sanding belt and clean the back side of the sanding belt and the drums. Also vacuum wood and abrasive dust from the inside of the machine.

Check for the following conditions and repair or replace when necessary:

- Loose mounting bolts.
- Worn switches.
- Worn or damaged cords and plugs.
- Damaged belts.
- Any other condition that could hamper the safe operation of this machine.
- Check the entire air system for leaks.

Lubrication

Wipe off all sawdust and abrasives on grease zerks and plugs before lubrication. When lubricating machine parts, your goal is to achieve adequate lubrication to prevent rust, and a thin layer of lubricant to prevent metal-to-metal friction. Too much lubrication will attract dirt and sawdust, and as a result, these parts could lose freedom of movement.

- After 150 hours of use lubricate the bearings with one squirt of automotive-grade grease at the designated points, see **Figure 31**.
- All other bearings are sealed and permanently lubricated, simply leave them alone until they need to be replaced. Do not lubricate them.

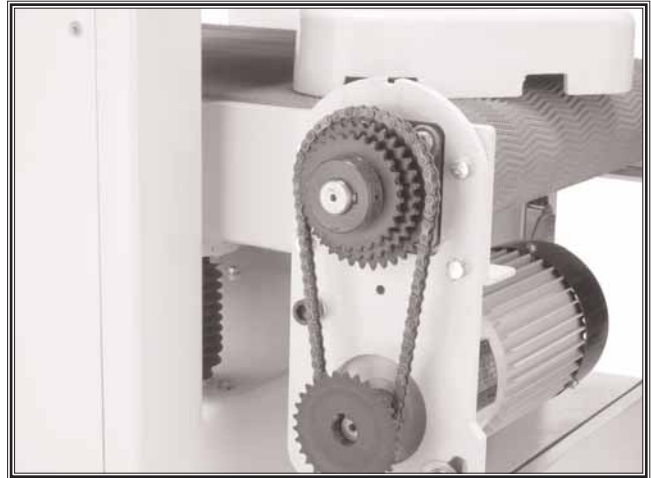

Figure 30. Conveyor speed change.

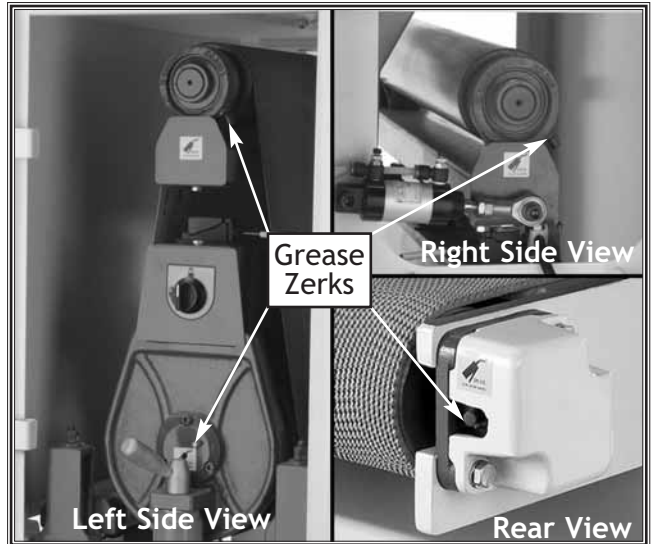

Figure 31. Grease zerk locations.

- After every 20-40 hours of use, lubricate the elevation screws, chains, sprockets, and the table guides under the table with a light coating of white lithium grease. See **Figure 32**.

Cleaning Belts

To increase working life of your sanding belts, we recommend that you routinely clean them with a Pro-Stik® Cleaning Pad shown in **Figure 33**.

To clean the belts, simply set your table to the thickness of the cleaning pad and run the pad through the sander two or three times. *DO NOT take too deep of a cut. The belt should barely touch the cleaning pad!*

Clean sanding belts whenever they decrease in performance due to heavy loading.

Servicing Separators

The moisture bowl on the regulator needs to be emptied and cleaned whenever it gets more than half full. See **Figure 34**.

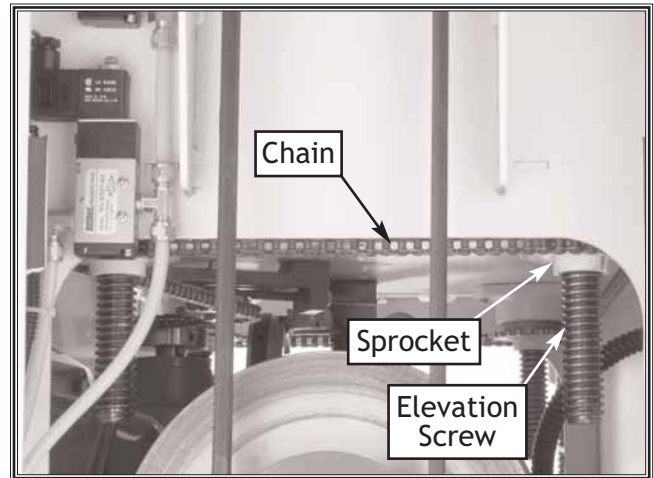

Figure 32. Lubrication points.



Figure 33. Pro Stik® cleaning pad.



Figure 34. Drain the moisture bowl often.

Servicing Brake

Any grease or oil on the emergency brake rotor creates the potential for reduced emergency braking ability. Check the brake rotor (shown in **Figure 35**) regularly to make sure it is clean. If it needs cleaning, only use automotive brake parts cleaner and a dry rag. **DO NOT** use water!

The brake pads shown in **Figure 36** will eventually need to be replaced.

To check the condition of the brake pads, do these steps:

1. **TURN-OFF** and **LOCK** the master power switch so no power can go to your sander and shut off the air pressure!
2. Remove the lower right cover.
3. Measure the thickness of each pad. If a pad is below $\frac{1}{8}$ ", then replace both.

To replace the brake pads, do these steps:

1. **TURN-OFF** and **LOCK** the master power switch so no power can go to your sander, and shut off the air pressure!
2. Use a 14mm wrench and remove the two caliper anchor pin retaining nuts and washer. See **Figure 35**.
3. Use ViceGrip® or similar pliers to clamp on the anchor pin end and pull the pin from the caliper mount and remove the springs. See **Figure 35**.
4. If the rotor is damaged, remove it and have it surfaced at a machine shop. Clean the rotor with automotive brake parts cleaner and handle it with a dry rag when installing.
5. To finish the job, install the new brake pads, reassemble and mount the caliper, and reconnect the air line if removed.
6. Test emergency brake operation!

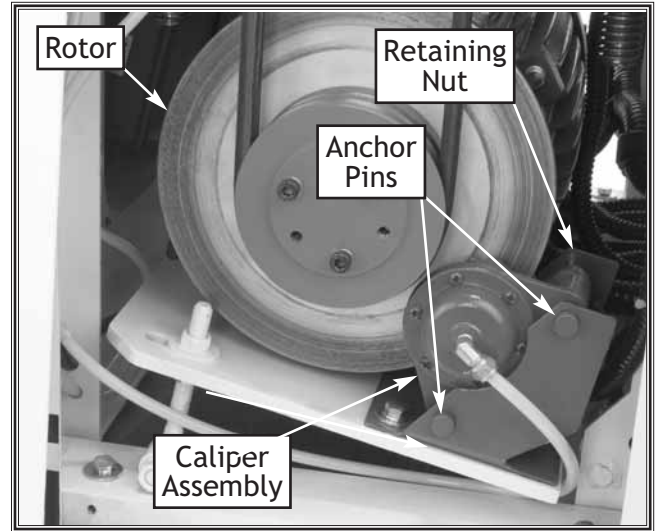

Figure 35. Brake assembly.

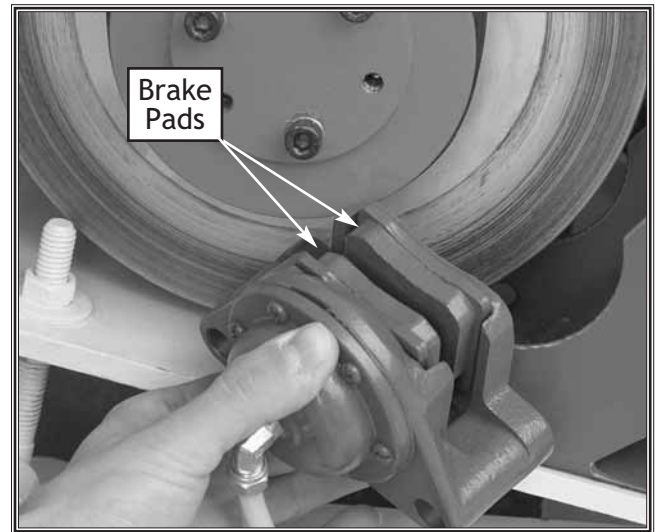

Figure 36. Brake caliper removed for access to brake pads.

Changing V-Belts

Check the V-belts periodically to check for signs of glazing, cracking or fraying. If any of these conditions are present, change both V-belts.

To change the V-belts, do these steps:

1. **TURN-OFF** and **LOCK** the master power switch so no power can go to your sander and shut off the air pressure!
2. Open both right-side upper and lower access covers.
3. Remove the two screws and the safety cover for access to the upper pulley. See **Figures 37**.
4. Use a 14mm wrench and remove the upper caliper anchor pin retaining nut and washer. See **Figure 38**.
5. Use ViceGrip® or similar pliers to clamp on the anchor pin end and pull the pin from the caliper mount and remove the springs. See **Figure 38**.
6. Pivot the caliper down and away from the rotor for belt clearance.
7. Remove the upper belt adjustment nut and washer. See **Figure 38**.
8. Pry the motor base plate upward to de-tension the belts and roll the belts off of the motor pulley.
9. Install the new V-belts.
10. Replace the upper belt adjustment nut and washer, and tension the belts.
11. The V-belt is properly tensioned when it will move no more than $\frac{3}{4}$ " in the center with moderate pressure from your thumb.
12. Reassemble in reverse order and test the emergency brake operation.



Figure 37. Upper pulley exposed.

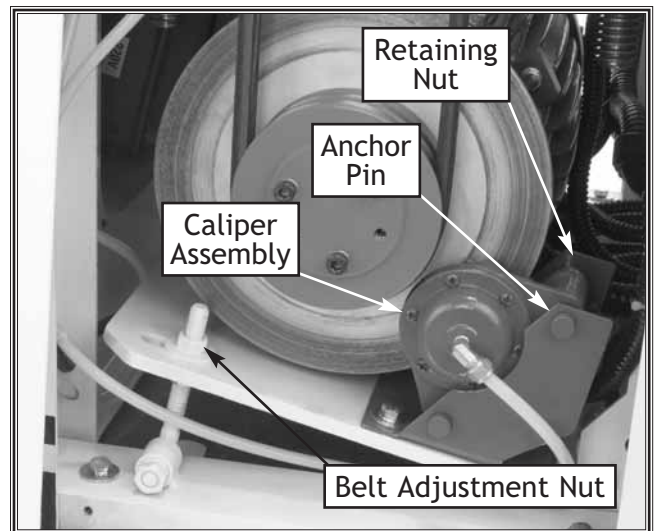

Figure 38. Belt removal access.

Troubleshooting

SYMPTOM	POSSIBLE CAUSE	HOW TO REMEDY
Motor will not start; fuses or circuit breakers blow.	<ol style="list-style-type: none"> 1. Low voltage. 2. Open circuit in motor or loose or shorted connections. 3. Short circuit in motor or loose connections. 4. Incorrect fuses or circuit breakers. 5. Faulty start capacitor. 6. Faulty motor. 	<p>Check power line for proper voltage. Inspect all lead connections on motor for loose, shorted, or open connections and replace or repair. Inspect all connections on motor for loose or shorted terminals or worn insulation. Install correct fuses or circuit breakers. Replace the start capacitor and do not to overload motor. Replace motor.</p>
Motor overheats.	<ol style="list-style-type: none"> 1. Motor overloaded. 2. Air circulation through the motor restricted. 	<p>Reduce load on motor. Clean out motor to provide normal air circulation.</p>
Motor stalls (resulting in blown fuses or tripped circuit).	<ol style="list-style-type: none"> 1. Short circuit in motor or loose connections. 2. Low voltage. 3. Incorrect fuses or circuit breakers in power line. 4. Motor overloaded. 5. Faulty run capacitor. 	<p>Inspect connections on motor for loose or shorted terminals or worn insulation. Correct the low voltage conditions. Install correct fuses or circuit breakers.</p> <p>Reduce load on motor. Replace the run capacitor.</p>
Machine slows when operating.	<ol style="list-style-type: none"> 1. Feed rate too high. 2. Depth of cut too great. 	<p>Feed workpiece slower. Reduce depth of cut.</p>
Loud, repetitious noise coming from machine	<ol style="list-style-type: none"> 1. Pulley set screws or keys are missing or loose. 2. Motor fan is hitting the cover. 3. V-belt is defective. 	<p>Inspect keys and set screws. Replace or tighten if necessary. Tighten fan. Replace V-belt. See Maintenance section.</p>
Machine is loud, overheats or bogs down in the cut.	<ol style="list-style-type: none"> 1. Excessive depth of cut. 2. Dull sanding belt. 	<p>Decrease depth of cut. Replace sanding belt.</p>
Edges of wood are rounded.	Excessive depth of cut.	Reduce depth of cut.
Uneven thickness from left to right of board.	<ol style="list-style-type: none"> 1. Feed table not parallel to sanding roller. 2. Feed belt is worn. 	<p>Adjust the table. Replace feed belt.</p>
Workpiece slips on feed belt.	<ol style="list-style-type: none"> 1. Pressure rollers set too high. 2. Dirty feed belt. 3. Feed belt is worn. 	<p>Lower pressure rollers. Clean feed belt. Replace feed belt.</p>
Straight strip of notches on workpiece.	Pressure rollers are dirty or damaged.	Clean or repair pressure rollers.
Snake shaped marks on workpiece.	Sanding belt damaged or dirty.	Clean or replace sanding belt.

W1709 Wiring Diagram

⚠ DANGER
 Disconnect power from machine before performing any electrical service. Failure to do this will result in a shock hazard leading to injury or death.

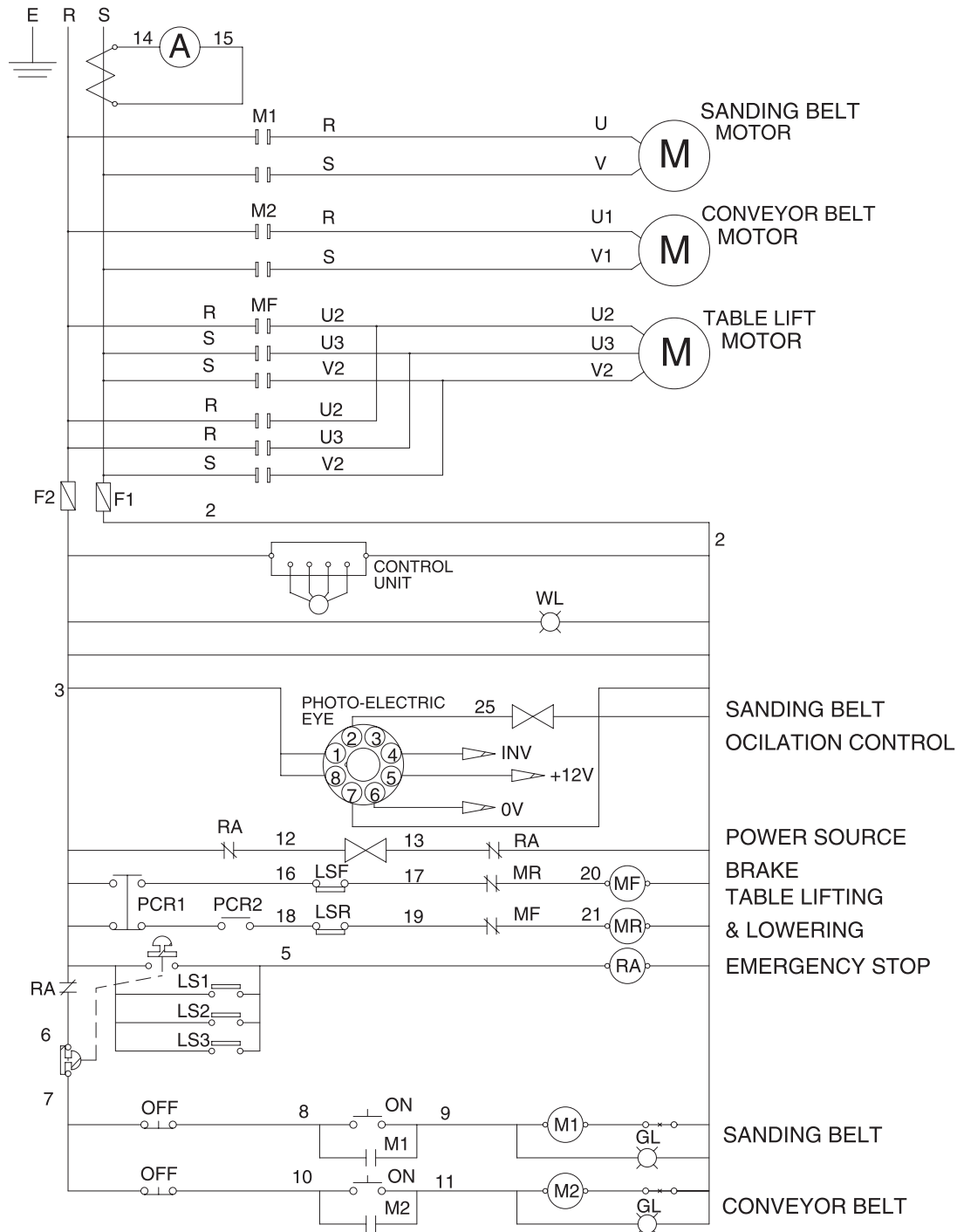

MAINTENANCE

W1709 Control Panel Wiring Connections

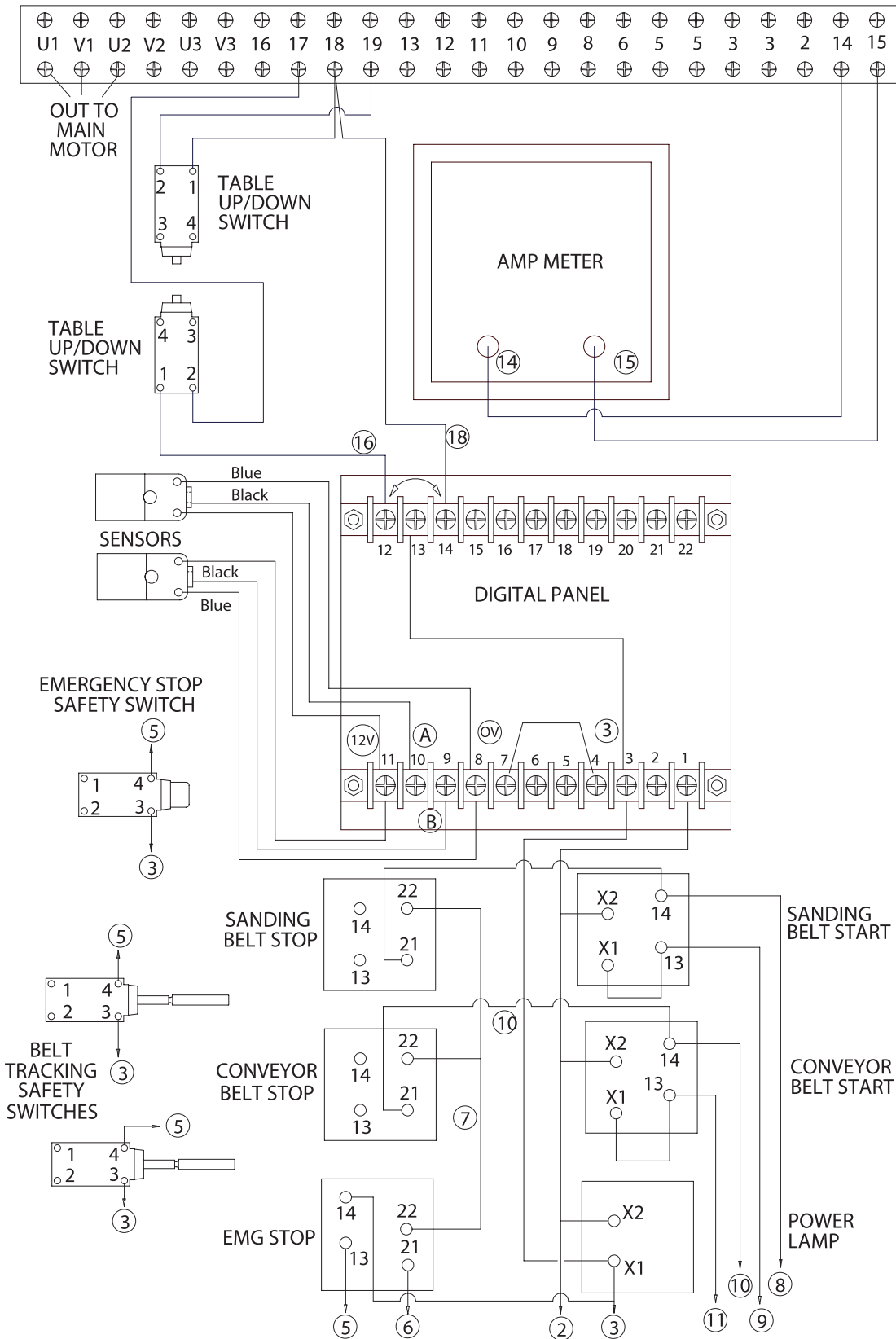

MAINTENANCE

W1709 Switch Box Wiring Connections

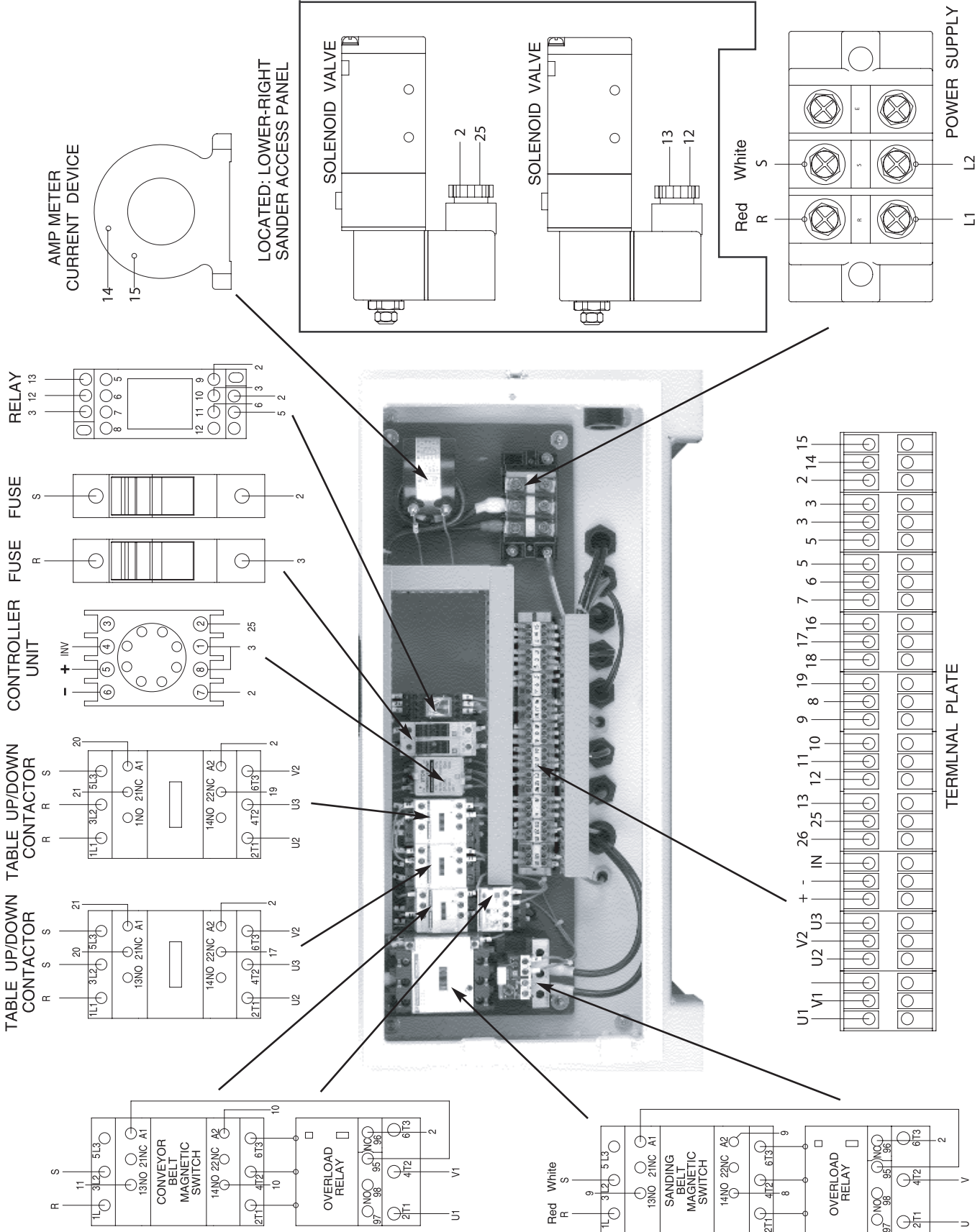

MAINTENANCE

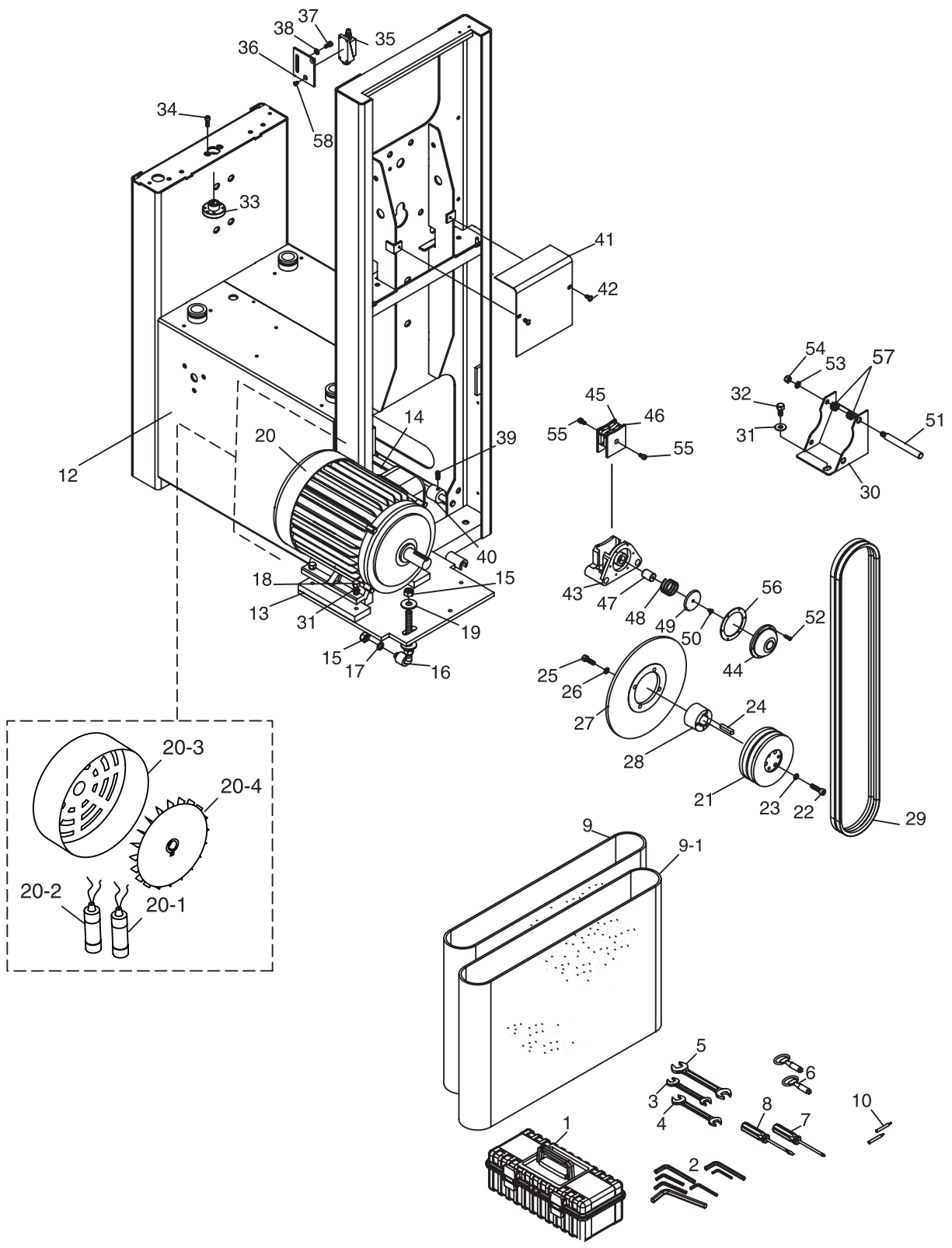

REF	PART #	DESCRIPTION
1	X1709001	TOOL BOX
2	X1709002	HEX WRENCH SET
3	XPWR810	COMBO WRENCH 8 X 10MM
4	XPWR1214	COMBO WRENCH 12 X 14MM
5	XPWR1719	COMBO WRENCH 17 X 19MM
6	X1709006	DOOR HANDLE
7	X1709007	PHILLIP'S SCREWDRIVER
8	X1709008	SLOT SCREWDRIVER
9	X1709009	A.O. SANDING BELT (150 GRIT)
9-1	X1709009-1	A.O. SANDING BELT (100 GRIT)
-	D3305	A.O. SANDING BELT (60 GRIT)
-	D3306	A.O. SANDING BELT (80 GRIT)
-	D3307	A.O. SANDING BELT (100 GRIT)
-	D3308	A.O. SANDING BELT (120 GRIT)
-	D3309	A.O. SANDING BELT (150 GRIT)
-	D3310	A.O. SANDING BELT (180 GRIT)
-	D3311	A.O. SANDING BELT (220 GRIT)
10	X1709010	LIMIT SWITCH ROD
12	X1709012	MACHINE FRAME
13	X1709013	MOTOR BASE
14	X1709014	MOTOR BASE HINGE
15	XPN06	HEX NUT 1/2"-12
16	X1709016	ADJUSTMENT ROD
17	XPLW07	LOCK WASHER 1/2"
18	XPB24	HEX BOLT 3/8"-16 X 1 1/4"
19	XPW01	FLAT WASHER 1/2"
20	X17091109	MOTOR 7 1/2 HP, 1PH
20-1	X17091109-1	START CAP. (500MFD 250VAC)
20-2	X17091109-2	RUN CAPACITOR (50MFD 300VAC)
20-3	X17091109-3	FAN COVER
20-4	X17091109-4	FAN
21	X1709021	PULLEY
22	XPSB11	CAP SCREW 5/16"-18 X 1 1/4"
23	XPLW01	LOCK WASHER 5/16"

REF	PART #	DESCRIPTION
24	X1709024	KEY 8 X 8 X 55MM
25	XPB12	HEX BOLT 5/16"-18 X 1 1/4"
26	XPLW01	LOCK WASHER 5/16"
27	X1709027	BRAKE DISC
28	X1709028	PULLEY BUSHING
29	XPVA68	V-BELT A-68
30	X1709030	BRAKE BRACKET
31	XPW02	FLAT WASHER 3/8"
32	XPB21	HEX BOLT 3/8"-16 X 3/4"
33	X1709033	FLANGE HUB
34	XPSB05	CAP SCREW 1/4"-20 X 3/4"
35	X17091126	LIMIT SWITCH
36	X1709036	LIMIT SWITCH PLATE
37	XPB19	HEX BOLT 1/4"-20 X 1 1/2"
38	XPW06	FLAT WASHER 1/4"
39	XPSB07	CAP SCREW 5/16"-18 X 3/4"
40	X1709040	COLLAR
41	X1709041	PULLEY COVER
42	XPS04	PHLP HD SCR 1/4"-20 X 1/2"
43	X1709043	BRAKE HOUSING
44	X1709044	BRAKE FRONT GUARD
45	X17091302-1	BRAKE LINING
46	X17091302-2	BRAKE LINING
47	X1709047	BRAKE ARBOR
48	X1709048	BRAKE SPRING
49	X1709049	BRAKE INSIDE PIECE
50	XPFH12M	FLAT HD SCR M6-1 X 25
51	X1709051	BRAKE PIN
52	XPSB10M	CAP SCREW M5-0.8 X 15
53	XPLW04	LOCK WASHER 3/8"
54	XPN08	HEX NUT 3/8"-16
56	X17091313	BRAKE GASKET
57	X1709057	SPRING
58	XPS80	PHLP HD SCR 3/16"-32 X 1/4"

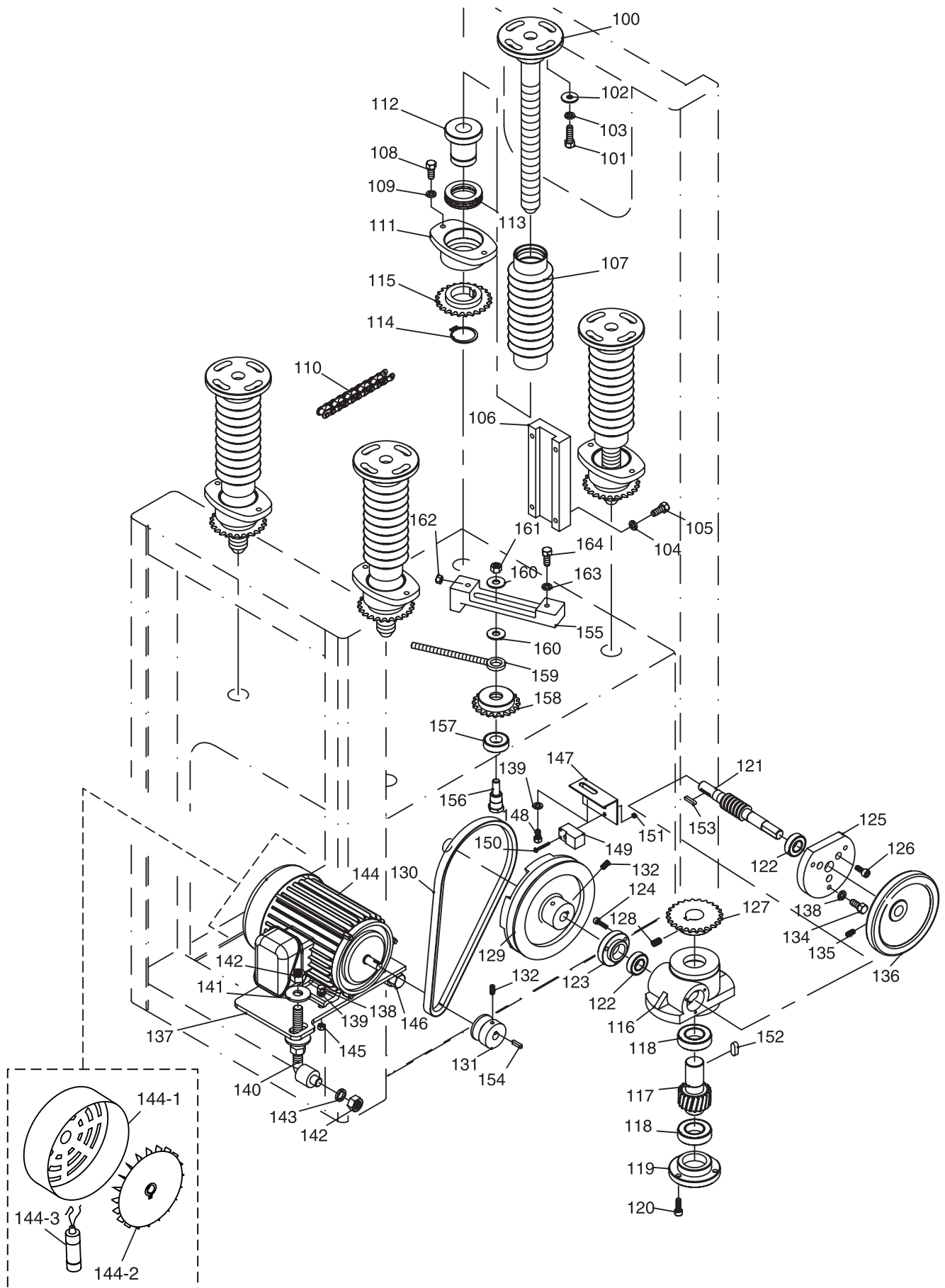

REF	PART #	DESCRIPTION
100	X1709100	ELEVATION SCREW
101	XPB03	HEX BOLT 5/16"-18 X 1"
102	XPW07	FLAT WASHER 5/16"
103	XPLW01	LOCK WASHER 5/16"
104	XPLW04	LOCK WASHER 3/8"
105	XPB18	HEX BOLT 3/8"-16 X 1"
106	X1709106	ELEVATION BRACKET
107	X1709107	DUST GUARD BELLOW
108	XPB07	HEX BOLT 5/16"-18 X 3/4"
109	XPLW01	LOCK WASHER 5/16"
110	X1709110	CHAIN
111	X1709111	NUT HOUSING
112	X1709112	COLLAR
113	XP51107	THRUST BEARING 51107
114	XPR12M	EXT RETAINING RING 35MM
115	X1709115	SPROCKET WHEEL
116	X1709116	ELEVATION GEAR BOX
117	X1709117	WORM GEAR
118	XP6005	BALL BEARING 6005
119	X1709119	BEARING CAP
120	XPSB05	CAP SCREW 1/4"-20 X 3/4"
121	X1709121	WORM SHAFT
122	XP6002	BALL BEARING 6002
123	X1709123	BEARING CAP
124	XPSB33	CAP SCREW 10-24 X 3/4"
125	X1709125	BEARING CAP
126	XPSB01	CAP SCREW 1/4"-20 X 5/8"
127	X1709127	SPROCKET WHEEL
128	XPSS08	SET SCREW 5/16"-18 X 1/2"
129	X1709129	PULLEY
130	XPVA28	V-BELT A-28
131	X1709131	PULLEY
132	XPSS07	SET SCREW 1/4"-20 X 1/2"
133	XPLW01	LOCK WASHER 5/16"

REF	PART #	DESCRIPTION
134	XPB32	HEX BOLT 5/16"-18 X 5/8"
135	XPSS07	SET SCREW 1/4"-20 X 1/2"
136	X1709136	HAND WHEEL
137	X1709137	MOTOR BASE
138	XPB44	HEX BOLT 1/2"-20 X 3/4"
139	XPLW02	LOCK WASHER 1/4"
140	X1709140	ADJUSTMENT ROD
141	XPW01	FLAT WASHER 1/2"
142	XPNO6	HEX NUT 1/2"-12
143	XPLW07	LOCK WASHER 1/2"
144	X17092331	MOTOR 1/3 HP, 1 PH
144-1	X17092331-1	FAN COVER
144-2	X17092331-2	FAN
144-3	XPC150	CAPACITOR (150MFD 250VAC)
145	XPNO5	HEX NUT 1/4"-20
146	XPB73	HEX BOLT 1/2"-13 X 4 1/2"
147	X1709147	MOUNTING PLATE
148	XPB19	HEX BOLT 1/4"-20 X 1/2"
149	X17092336	PROXIMITY SWITCH
150	XPS34	PHLP HD SCR M3-0.5 X 25
151	XPNO7M	HEX NUT M3-0.5
152	XPK14	KEY 5/16" X 5/16" X 3/4"
153	XPK48M	KEY 4 X 4 X 20MM
154	XPK48M	KEY 4 X 4 X 20MM
155	X1709155	ADJUSTMENT PIECE
156	X1709156	SPROCKET SHAFT
157	XP6003	BALL BEARING 6003
158	X1709158	SPROCKET WHEEL
159	X1709159	ADJUSTMENT ROD
160	XPW02	FLAT WASHER 3/8"
161	XPNO8	HEX NUT 3/8"-16
162	XPNO2	HEX NUT 5/16"-18
163	XPLW01	LOCK WASHER 5/16"
164	XPB07	HEX BOLT 5/16"-18 X 3/4"

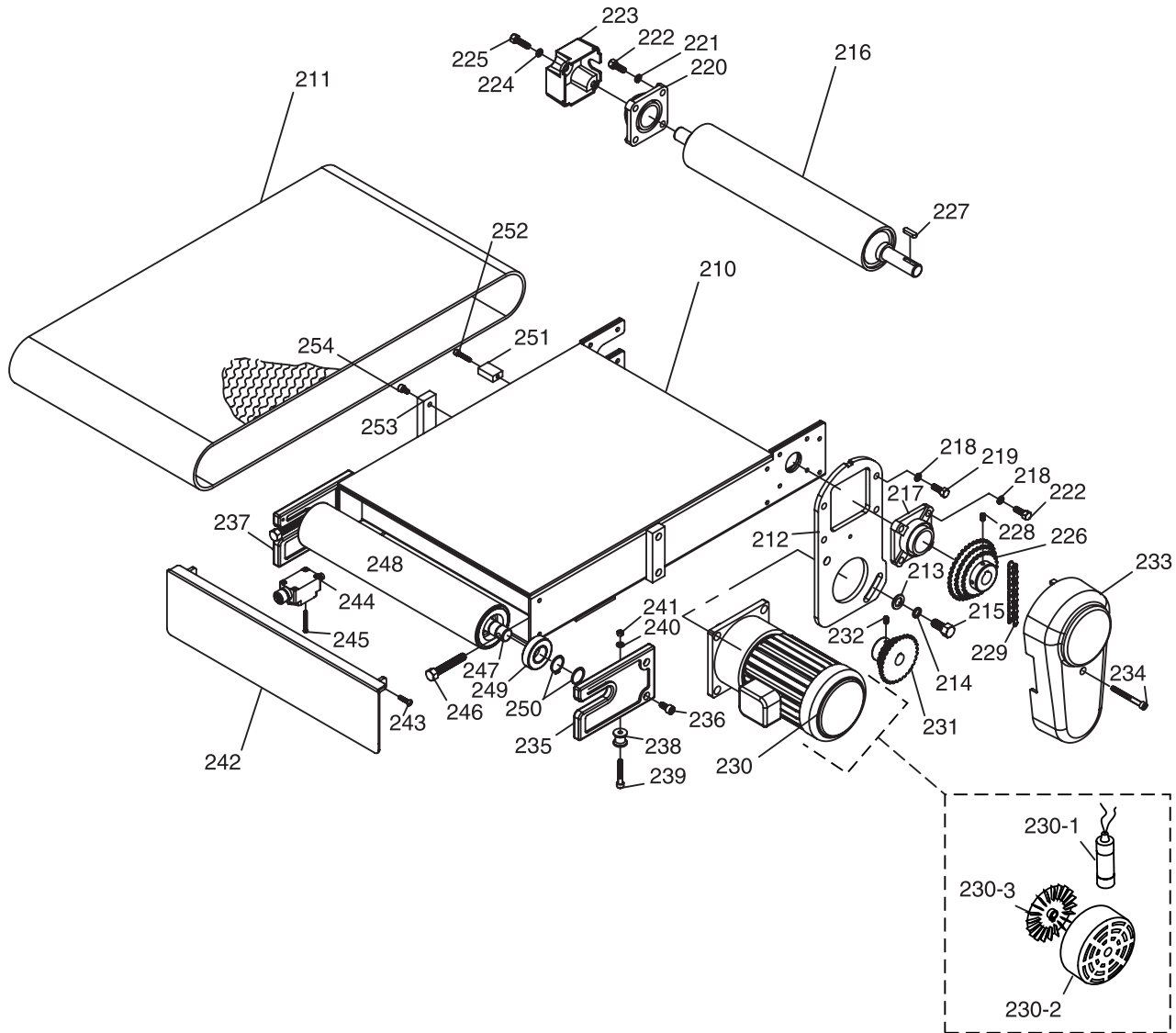

REF	PART #	DESCRIPTION
210	X1709210	CONVEYOR TABLE
211	X17093102	CONVEYOR BELT
212	X1709212	MOUNTING PLATE
213	XPW15	FLAT WASHER $\frac{9}{16}$ "
214	XPLW08M	LOCK WASHER 14MM
215	X1709215	HEX BOLT M14-2 X 30
216	X1709216	OUTFEED ROLLER
217	X1710217	BALL BEARING UCF205
218	XPLW04	LOCK WASHER $\frac{3}{8}$ "
219	XPB18	HEX BOLT $\frac{3}{8}$ "-16 X 1"
220	X1710217	BALL BEARING UCF205
221	XPLW04	LOCK WASHER $\frac{3}{8}$ "
222	XPB18	HEX BOLT $\frac{3}{8}$ "-16 X 1"
223	X1709223	BEARING CAP
224	XPLW04	LOCK WASHER $\frac{3}{8}$ "
225	XPB24	HEX BOLT $\frac{3}{8}$ "-16 X $1\frac{1}{4}$ "
226	X1709226	SPROCKET WHEEL
227	XPK11	KEY $\frac{5}{16}$ " X $\frac{5}{16}$ " X $1\frac{3}{16}$ "
228	XPSS08	SET SCREW $\frac{5}{16}$ "-18 X $\frac{1}{2}$ "
229	X1709229	CHAIN
230	X17093123	MOTOR $\frac{1}{2}$ HP, 1 PH
230-1	X17093123-1	FAN COVER
230-2	X17093123-2	FAN
230-3	XPC040UF	RUN CAPACITOR (40MFD 350VAC)

REF	PART #	DESCRIPTION
231	X1709231	SPROCKET WHEEL
232	XPSS08	SET SCREW $\frac{5}{16}$ "-18 X $\frac{1}{2}$ "
233	X1709233	CHAIN GUARD
234	X1709234	SPCL PHLP HD SCR $\frac{5}{16}$ "-18 X 3"
235	X17093131	INFEED ROLLER BRACKET
236	XPSB16	CAP SCREW $\frac{3}{8}$ "-16 X $\frac{3}{4}$ "
237	X17093133	INFEED ROLLER BRACKET
238	X1709238	POSITIONING WHEEL
239	XPSB70	CAP SCREW $\frac{5}{16}$ "-18 X 2"
240	XPLW01	LOCK WASHER $\frac{5}{16}$ "
241	XPNO2	HEX NUT $\frac{5}{16}$ "-18
242	X1709242	FRONT BRAKE COVER
243	XPS19	PHLP HD SCR $\frac{1}{4}$ "-20 X 1"
244	X17093142	LIMIT SWITCH
245	XPS31	PHLP HD SCR 10-24 X $1\frac{3}{4}$ "
246	X1709246	ADJ. HEX BOLT $\frac{1}{2}$ "-12 X 3"
247	X1709247	SHAFT
248	X1709248	INFEED ROLLER
249	XP6206	BALL BEARING 6206
250	XPR15M	EXT RETAINING RING 30MM
251	X1709251	ELEVATION LIMITER
252	XPSB32	CAP SCREW $\frac{1}{4}$ "-20 X $1\frac{1}{4}$ "
253	X1709253	ELEVATION SLIDERAIL
254	XPSB30	CAP SCREW $\frac{5}{16}$ "-18 X $\frac{1}{2}$ "

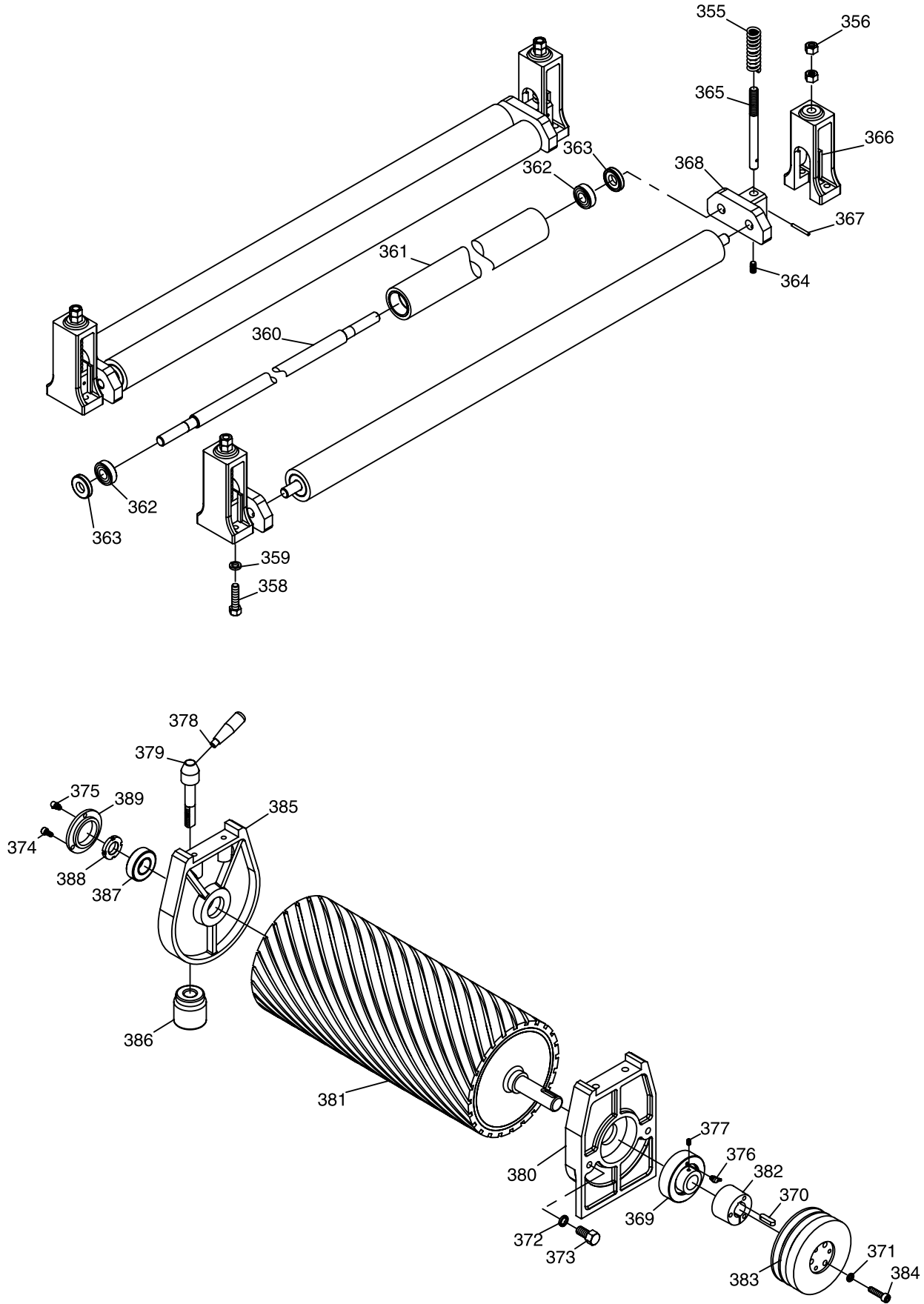

REF	PART #	DESCRIPTION
355	X1709355	SPRING
356	XPN08	HEX NUT $\frac{3}{8}$ "-16
358	XPB07	HEX BOLT $\frac{5}{16}$ "-18 X $\frac{3}{4}$
359	XPLW01	LOCK WASHER $\frac{5}{16}$ "
360	X1709360	PISTON ROLLER SHAFT
361	X17094202	PISTON ROLLER
362	XP6001	BALL BEARING 6001
363	X1709363	BEARING COLLER
364	XPSS07	SET SCREW $\frac{1}{4}$ "-20 X $\frac{1}{2}$ "
365	X1709365	PISTON ROLLER ADJ. ROD
366	X1709366	PISTON BRACKET
367	XPRP55M	ROLL PIN 3 X 27MM
368	X1709368	PISTON SLIDERAIL
369	X1709369	BEARING UCC206
370	XPK11	KEY $\frac{5}{16}$ " X $\frac{5}{16}$ " X $1\frac{3}{16}$ "
371	XPLW01	LOCK WASHER $\frac{5}{16}$ "
372	XPLW07	LOCK WASHER $\frac{1}{2}$ "

REF	PART #	DESCRIPTION
373	XPB41	HEX BOLT $\frac{1}{2}$ "-12 X $1\frac{1}{2}$ "
374	XPSB04	CAP SCREW $\frac{1}{4}$ "-20 X $\frac{1}{2}$ "
375	X1709375	GREASE FITTING $\frac{1}{4}$ "-28
376	X1709376	GREASE FITTING $\frac{1}{4}$ "-28 X 45°
377	XPSB85M	CAP SCREW M6-1 X 6
378	X17095205	LOCK LEVER HANDLE
379	X17095206	LOCK LEVER SHAFT
380	X1709380	BEARING HOUSING
381	X1709381	RUBBER ROLLER
382	X1709382	FASTENING TUBE
383	X1709383	PULLEY
384	XPSB11	CAP SCREW $\frac{5}{16}$ "-18 X $1\frac{1}{4}$ "
385	X1709385	BEARING HOUSING
386	X1709386	BEARING BRACKET PAD
387	XP6205	BALL BEARING 6205-2RS
388	X1709388	SPANNER NUT
389	X1709389	BEARING CAP

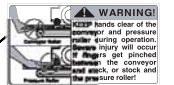
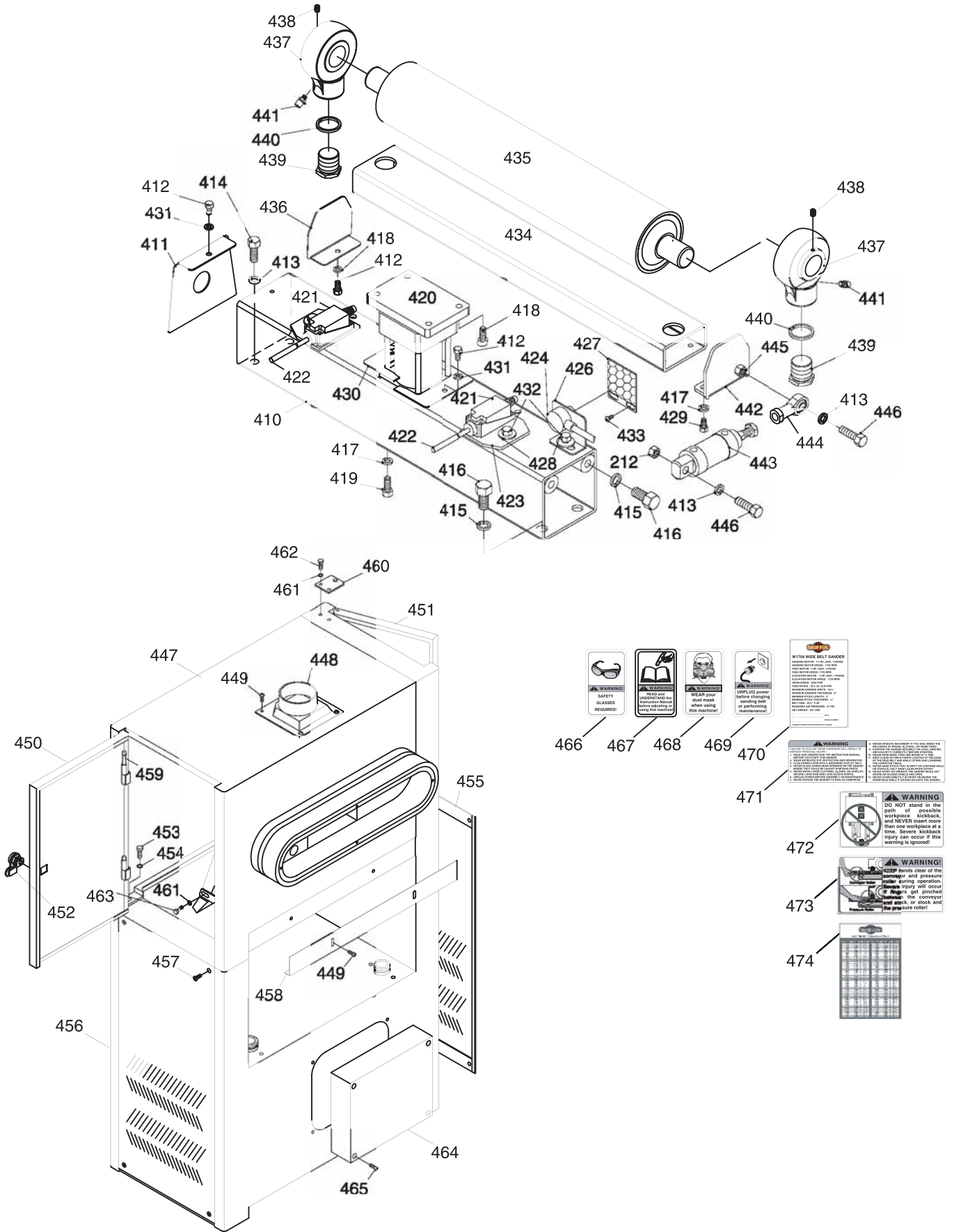

REF	PART #	DESCRIPTION
410	X1709410	SQUARE FRAME
411	X1709411	SQUARE FRAME SEAL (LEFT)
412	XPFH03	FLAT HD SCR 1/4"-20 X 1/2"
413	XPLW04	LOCK WASHER 3/8"
414	XPB18	HEX BOLT 3/8"-16 X 1"
415	XPLW07	LOCK WASHER 1/2"
416	XPB53	HEX BOLT 1/2"-12 X 1"
417	XPLW01	LOCK WASHER 5/16"
418	XPSB07	CAP SCREW 5/16"-18 X 3/4"
419	XPB09M	HEX BOLT M8-1.25 X 20
420	X1709420	AIR CYLINDER
421	X17096115	LIMIT SWITCH
422	X17096116	LIMIT SWITCH TUBE
423	X1709423	LIMIT SWITCH HOLDER
424	X17096118	SENSOR (PHOTO-ELECTRIC EYE)
426	X1709426	SENSOR PLATE
427	X17096120	SENSOR REFLECTOR
428	XPW07	FLAT WASHER 5/16"
429	XPB09	HEX BOLT 5/16"-18 X 1/2"
430	X1709430	COVER
431	XPLW02	LOCK WASHER 1/4"
432	XPB07	HEX BOLT 5/16"-18 X 3/4"
433	XPS07M	PHLP HD SCR M4-0.7 X 8
434	X1709434	UPPER ROLLER BRACKET
435	X1709435	UPPER ROLLER
437	X1709437	BEARING ASSY. UCECH6206
438	XPSS02M	SET SCREW M6-1 X 6
439	X1709439	PLUG
440	X1709440	SPLIT RING
441	X1709441	GREASE FITTING 1/4"-28
443	X17096210	AIR CYLINDER

REF	PART #	DESCRIPTION
444	X17096211	CLEVIS W/BEARING
445	XPN08	HEX NUT 3/8"-16
446	XPSB16	CAP SCREW 3/8"-16 X 3/4"
447	X1709447	UPPER FRAME COVER
448	X1709448	DUST PORT 4"
449	XPS14M	PHLP HD SCR M6-1 X 12
450	X1709450	LEFT DOOR, UPPER FRAME
451	X1709451	RIGHT DOOR, UPPER FRAME
452	X1709452	DOOR LOCK
453	XPB86	HEX BOLT 5/16"-18 X 3/4"
454	XPW07	FLAT WASHER 5/16"
455	X1709455	RIGHT DOOR, LOWER FRAME
456	X1709456	LEFT DOOR, LOWER FRAME
457	XPS04	PHLP HD SCR 1/4"-20 X 1/2"
458	X1709458	PLATE
459	X1709459	HINGE
460	X1709460	MOUNTING PLATE
461	XPLW02	LOCK WASHER 1/4"
462	XPB19	HEX BOLT 1/4"-20 X 1/2"
463	XPB02M	HEX BOLT M6-1 X 12
464	X1709464	MOTOR COVER
465	XPSB04	CAP SCREW 1/4"-20 X 1/2"
466	X1709466	LABEL, SAFETY GLASSES
467	X1709467	LABEL, READ MANUAL
468	X1709468	LABEL, DUST MASK
469	X1709469	LABEL, UNPLUG POWER
470	X1709470	LABEL, MACHINE DATA
471	X1709471	LABEL, GENERAL WARNINGS
472	X1709472	LABEL, OPERATION WARNING
473	X1709473	LABEL, HAND WARNING
474	X1709474	LABEL, CONVERSION TABLE

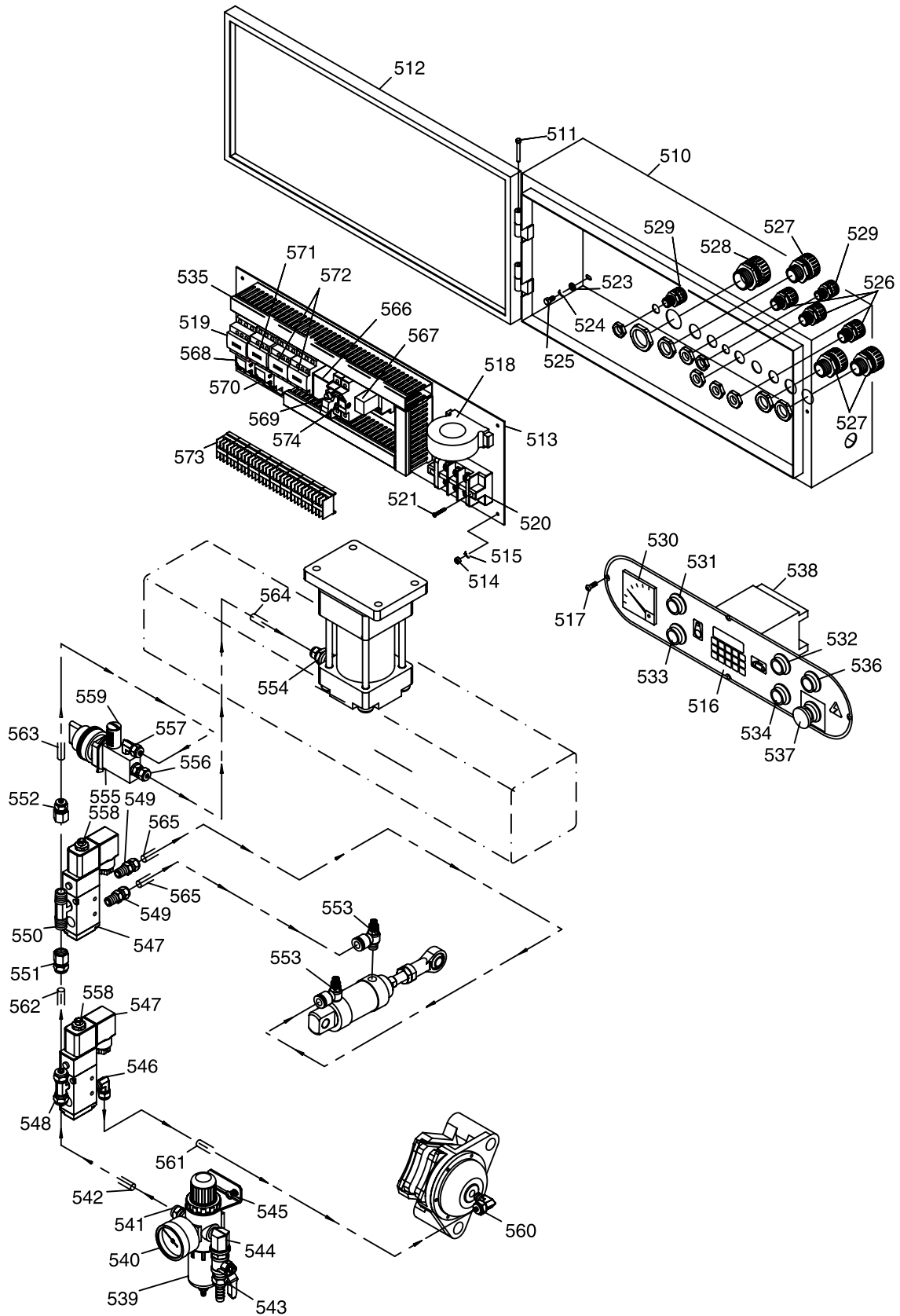

REF	PART #	DESCRIPTION
510	X1709510	ELECTRICAL CONTROL BOX
511	X1709511	HINGE
512	X1709512	CONTROL BOX
513	X1709513	BASE PLATE
514	XPN05	HEX NUT 1/4"-20
515	XPLW02	LOCK WASHER 1/4"
516	X17098107	CONTROL PANEL
517	XPS07M	PHLP HD SCR M4-0.7 X 8
518	X17098109	PROPORTIONAL CURRENT DEVICE
519	X17098111	MAG. CONTACT (LRD-3357)
520	X1709520	POWER WIRE TERMINAL
521	XPS51M	PHLP HD SCR M4-0.7 X 30
522	X1709522	TERMINAL PLATE
523	XPW06	FLAT WASHER 1/4"
524	XPLW02	LOCK WASHER 1/4"
525	XPB19	HEX BOLT 1/4"-20 X 1/2"
526	X1709526	PU CONNECTOR 1/2"
527	X1709527	PU CONNECTOR 3/4"
528	X1709528	CABLE CONNECTOR 1"
529	X1709529	PU CONNECTOR 3/8"
530	X17098126	AMP METER
531	X17098128-1	START SWITCH
532	X17098128-2	START SWITCH
533	X17098129-1	STOP SWITCH
534	X17098129-2	STOP SWITCH
535	X1709535	WIRE COLUMN
536	X17098130	POWER INDICATION LIGHT
537	X17098131	EMERGENCY STOP SWITCH
538	X17098133	COMPUTER
539	X1709539	FILTER CUP 1/4"
540	X1709540	PRESSURE REGULATOR 1/4"
541	X1709541	BRONZE CONNECTOR 1/4T X 5/16N
542	X1709542	FLEXIBLE HOSE 8MM

REF	PART #	DESCRIPTION
543	X1709542	AIR VALVE 1/4"
544	X1709544	ELBOW 1/4T X 5/16N
545	XPS22	PHLP HD SCR 10-24 X 5/8"
546	X1709546	ELBOW 1/4 X 1/8 T
547	X1709547	SOLENOID VALVE
548	X1709548	T-JOINT 5/16N X 1/8T X 5/16N
549	X1709549	PLASTIC CONNECTOR 1/4N X 1/4T
550	X1709550	T-JOINT 1/4T X 1/4T X 1/4T
551	X1709551	PLASTIC CONNECTOR 5/16N X 1/4T
552	X1709552	PLASTIC CONNECTOR 1/4N X 1/4T
553	X1709553	THROTTLE VALVE 1/8"
554	X1709554	PLASTIC CONNECTOR 1/4N X 3/8T
555	X1709555	AIR SWITCH 1/8"
556	X1709556	PLASTIC CONNECTOR 1/4N X 1/8T
557	X1709557	PLASTIC CONNECTOR 1/4N X 1/8T
558	X1709558	BUFFER 1/8"
559	X1709559	SILENCER 1/8"
560	X1709560	PLASTIC CONNECTOR 5/16N X 1/8T
561	X1709561	FLEXIBLE HOSE 8MM
562	X1709562	FLEXIBLE HOSE 8MM
563	X1709563	FLEXIBLE HOSE 6MM
564	X1709564	FLEXIBLE HOSE 6MM
565	X1709565	FLEXIBLE HOSE 6MM
566	X17098135	CONTROLLER UNIT
567	X17098136	RELAY
568	X17108112	OVERLOAD RELAY(LR3-D33)
569	X17098113	FUSE 4-AMP
570	X17098114	OVERLOAD RELAY (LR3D-086)
571	X17098115	MAG. CONTACT (LC1-096)
572	X17098115-1	MAG. CONTACT (LC1-096 (W/LOCK))
573	X170908118	TERMANAL PLATE
574	X17108113-1	FUSE HOUSING

Accessories

The following sander accessories may be available through your local Woodstock International Inc. Dealer. If you do not have a dealer in your area, these products are also available through online dealers. Please call or e-mail Woodstock International Inc. Customer Service to get a current listing of dealers at: 1-800 840-8420 or at sales@woodstockint.com.

The SHOP FOX® Heavy-Duty Roller Stands and Roller Tables make your sander safer and easier to use. All models feature convenient hand knobs for fast height adjustment and offer rigid steel construction. These stands are invaluable for supporting extra long workpieces on sanders. Go to <http://www.shopfox.biz/rollerstand.cfm> to view all of the available roller tables and stands.



The D2271 SHOP FOX® Heavy-Duty Roller Table is a versatile roller table wherever you need extra workpiece support for up to 1,000 lb. capacity. It features all-steel welded construction and measures 19" x 65" long. The roller table also comes with 9 ball bearing rollers with four independently adjustable legs for any leveling requirement. The roller table is also adjustable in height from 26³/₈" to 44¹/₈".



The W1100 SLICKPLANE® with Radius Blade produces an exceptionally smooth 1/16" radius or a 45° chamfer over the entire length of an edge after your workpiece. Crafted from rock maple, The **SLICKPLANE®** is designed to fit comfortably in your hand. A brass sole glides easily along the workpiece edge as two independently adjustable carbide-tipped cutters apply the finishing touch.

- W1101 1 Pr. Carbide-Tipped Radius Blades
- W1102 1 Pr. Carbide-Tipped Chamfer Blades



The D2258 Shop Flash™ is perfect for workshops with loud machinery running or when you must wear hearing protection. The shop flash built-in audible sound or flashing light or both alerts you when your shop phone rings. The Shop Flash™ requires no batteries and includes AC/DC adapter and microphone with 14' cord that easily attaches to your telephone.



The D3003 15" x 20" Cleaning Pad for Wide-Belt Sanders. The perfect accessory for wide-belt sanders, just set your table and feed this cleaning pad through for longer lasting abrasive belts. Pad measures 15" x 20" x 1¹/₈" high.



WARRANTY CARD

Name _____
Street _____
City _____ State _____ Zip _____
Phone Number _____ E-Mail _____ FAX _____
MODEL# _____ SERIAL# _____ PURCHASE DATE _____

The following information is given on a voluntary basis and is strictly confidential.

1. Where did you purchase your **SHOP FOX®** machine?
Store? _____ City? _____
2. How did you first learn about us?
____ Advertisement _____ Friend
____ Mail order Catalog _____ Local Store
____ World Wide Web Site
____ Other _____
3. Which of the following magazines do you subscribe to.
____ American Woodworker _____ Today's Homeowner
____ Cabinetmaker _____ WOOD
____ Family Handyman _____ Wooden Boat
____ Fine Homebuilding _____ Woodshop News
____ Fine Woodworking _____ Woodsmith
____ Home Handyman _____ Woodwork
____ Journal of Light Construction _____ Woodworker
____ Old House Journal _____ Woodworker's Journal
____ Popular Mechanics _____ Workbench
____ Popular Science _____ American How-To
____ Popular Woodworking
____ Other _____
4. Which of the following woodworking/remodeling shows do you watch?
____ Backyard America _____ The New Yankee Workshop
____ Home Time _____ This Old House
____ The American Woodworker _____ Woodwright's Shop
____ Other _____
5. What is your annual household income?
____ \$20,000-\$29,999 _____ \$60,000-\$69,999
____ \$30,000-\$39,999 _____ \$70,000-\$79,999
____ \$40,000-\$49,999 _____ \$80,000-\$89,999
____ \$50,000-\$59,999 _____ \$90,000 +
6. What is your age group?
____ 20-29 _____ 50-59
____ 30-39 _____ 60-69
____ 40-49 _____ 70 +
7. How long have you been a woodworker?
____ 0 - 2 Years _____ 8 - 20 Years
____ 2 - 8 Years _____ 20+ Years
8. How would you rank your woodworking skills?
____ Simple _____ Advanced
____ Intermediate _____ Master Craftsman
9. How many **SHOP FOX®** machines do you own? _____
10. What stationary woodworking tools do you own? Check all that apply.
____ Air Compressor _____ Panel Saw
____ Band Saw _____ Planer
____ Drill Press _____ Power Feeder
____ Drum Sander _____ Radial Arm Saw
____ Dust Collector _____ Shaper
____ Horizontal Boring Machine _____ Spindle Sander
____ Jointer _____ Table Saw
____ Lathe _____ Vacuum Veneer Press
____ Mortiser _____ Wide Belt Sander
____ Other _____
11. Which benchtop tools do you own? Check all that apply.
____ 1" x 42" Belt Sander _____ 6" - 8" Grinder
____ 5" - 8" Drill Press _____ Mini Lathe
____ 8" Table Saw _____ 10" - 12" Thickness Planer
____ 8" - 10" Bandsaw _____ Scroll Saw
____ Disc/Belt Sander _____ Spindle/Belt Sander
____ Mini Jointer
____ Other _____
12. Which portable/hand held power tools do you own? Check all that apply.
____ Belt Sander _____ Orbital Sander
____ Biscuit Joiner _____ Palm Sander
____ Circular Saw _____ Portable Planer
____ Detail Sander _____ Saber Saw
____ Drill/Driver _____ Reciprocating Saw
____ Miter Saw _____ Router
____ Other _____
13. What machines/supplies would you like to see?
____ 12" Table Saw _____ Radial Arm Saw
____ 12" Jointer _____ Panel Saw
____ Combination Planer/Joiner _____ Brass Hardware
____ Paint & Finish Supplies _____ Lumber
____ Contractor's Supplies
____ other _____
14. What new accessories would you like Woodstock International to carry?

15. Do you think your purchase represents good value?
____ Yes _____ No
16. Would you recommend **SHOP FOX®** products to a friend?
____ Yes _____ No
17. Comments: _____

CUT ALONG DOTTED LINE

FOLD ALONG DOTTED LINE

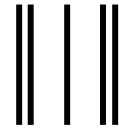
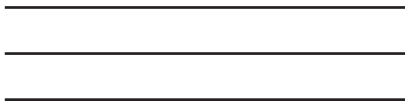

Place
Stamp
Here



WOODSTOCK INTERNATIONAL, INC.
P.O. BOX 2309
BELLINGHAM, WA 98227-2309



FOLD ALONG DOTTED LINE

TAPE ALONG EDGES--PLEASE DO NOT STAPLE

