

The Model H revisited

"A microscope specially designed for tropical medicine must have certain particular qualities. It must be not only optically as perfect as possible but exceptionally robust to withstand the rough treatment of travel, light, and easily portable. It must be resistant to heat, humidity and dust, and capable of every operation within the range of any high-power microscope." *John N. McArthur.*

While there is a strong and healthy competition in the field of desktop microscopes leading to a very varied and capable supply, the field microscope seems to have been completely forgotten by the manufacturers. This is to the point that one looking for a really good portable microscope will have better luck finding it in an antique shop than at his favourite scientific supplies distributor. Trying to find such a device, I quickly came to the conclusion that the best and most practical field microscope ever made was the Nikon Model H and I quickly acquired one. I fell immediately in love with the little device despite its average condition and as I kept searching for a better one, I soon found myself with four of them. Of course, my research was also based on curiosity and was mostly about finding more information about the remarkable but little known microscope. This is a record of my observations and research and should serve as an addendum and actualisation to the seminal article by Bill Amos "The Nikon Model H".

Nikon 携帯顕微鏡H

小型カメラの大きさで、携行が容易です。視野も広い。17mmとくも視野が広いです。人間眼に匹敵する大きさで、持ち運び、操作が簡単です。持ち運び、操作が簡単です。持ち運び、操作が簡単です。

●視野が広い。17mmとくも視野が広いです。人間眼に匹敵する大きさで、持ち運び、操作が簡単です。

●持ち運び、操作が簡単です。持ち運び、操作が簡単です。持ち運び、操作が簡単です。

●視野が広い。17mmとくも視野が広いです。人間眼に匹敵する大きさで、持ち運び、操作が簡単です。

●持ち運び、操作が簡単です。持ち運び、操作が簡単です。持ち運び、操作が簡単です。

●視野が広い。17mmとくも視野が広いです。人間眼に匹敵する大きさで、持ち運び、操作が簡単です。

●持ち運び、操作が簡単です。持ち運び、操作が簡単です。持ち運び、操作が簡単です。



この顕微鏡は、携帯用顕微鏡の第一人者として知られています。

●視野が広い。17mmとくも視野が広いです。人間眼に匹敵する大きさで、持ち運び、操作が簡単です。

●持ち運び、操作が簡単です。持ち運び、操作が簡単です。持ち運び、操作が簡単です。

●視野が広い。17mmとくも視野が広いです。人間眼に匹敵する大きさで、持ち運び、操作が簡単です。

●持ち運び、操作が簡単です。持ち運び、操作が簡単です。持ち運び、操作が簡単です。

●視野が広い。17mmとくも視野が広いです。人間眼に匹敵する大きさで、持ち運び、操作が簡単です。

●持ち運び、操作が簡単です。持ち運び、操作が簡単です。持ち運び、操作が簡単です。



性能および特徴		価格	
型番	NIKH	価格	15,000円
口径	17mm	重量	約150g
倍率	100倍	視野	約1.5mm
目鏡	10x	物鏡	10x
物鏡	10x	カメラ	17mm
カメラ	17mm	電池	単3電池
電池	単3電池	付属品	持ち運びケース
付属品	持ち運びケース	保証書	1年間
保証書	1年間	販売店	各主要家電店

An original Japanese flyer showing the portability of the model H.

History

The British scientist Dr John N. McArthur is the first to have described, then built a folded beam microscope in the 1930s. His simple design used two prisms to fold the standard 160mm light path of a microscope into a U shape, making it much more compact while retaining all its standard components. A number of McArthur microscopes were built upon the original design until the middle of the 1980s when demand dried out. It is interesting to see that it actually survived the Model H by a few years.

It is difficult nowadays to find traces of the Model H being used in the field. While it must certainly have been successful in its primary role as a parasitology diagnostic tool, little trace remains of that application. A few scientists, fortunately, were fond enough of the microscope to describe it in their publications and some of these can be found on the Internet. Following is an excerpt from a study on protists in the Rio Tinto (MBL Publications).

"During all visits to the sites, we used a field microscope (Nikon model H) for instant inspection of live material wet mounts immediately after sampling from the river. In this way, targeted collection of particular organisms for culture studies could be accomplished. Also, for ecological studies it is important to observe in the field since some protists are fragile and may not survive a trip back to the laboratory in Madrid." (Rio Tinto protist collection, isolation, and study, Erik Zettler and Linda Amaral Zettler)



Nikon model H field microscope being used by Dr. Amaral-Zettler to observe protists at the Origin site. © Erik Zettler and Linda Amaral Zettler

Bill Amos lauds the model H in its use aboard a moving boat:

"I have been especially thankful for this microscope when on ships with severe engine vibration or in rough seas. The Nikon Model H makes such studies almost effortless".

It also seems that the microscope was used in schools, especially in Japan: "We became scientists with a Model H" says Michio Akiyama of the Nikon historical club. In fact, my model HP shows every sign of student abuse and could well have spent the first part of its life in a university. One of the McArthur offshoots was designed and built for the Open University as a cheap microscope on which to follow biology distance learning courses.

The true call to fame for the Model H was when it became part of Skylab's cargo and a key part of many of the scientific experiments conducted on the American space station. NASA's documentation is complete and well organised and many traces of the 1970's missions can be found on their web site, including this small but fantastically informative picture showing most of the

biological experimentation laboratory. Another picture shows Pilot/scientist Kerwin actually using the Model H. Interestingly, the microscope was never called by its name in any of the publications, only ever being called the “Skylab Microscope” but it is fairly standard for NASA to give an internal descriptor to a device once it has been accepted, and eventually modified for space use.

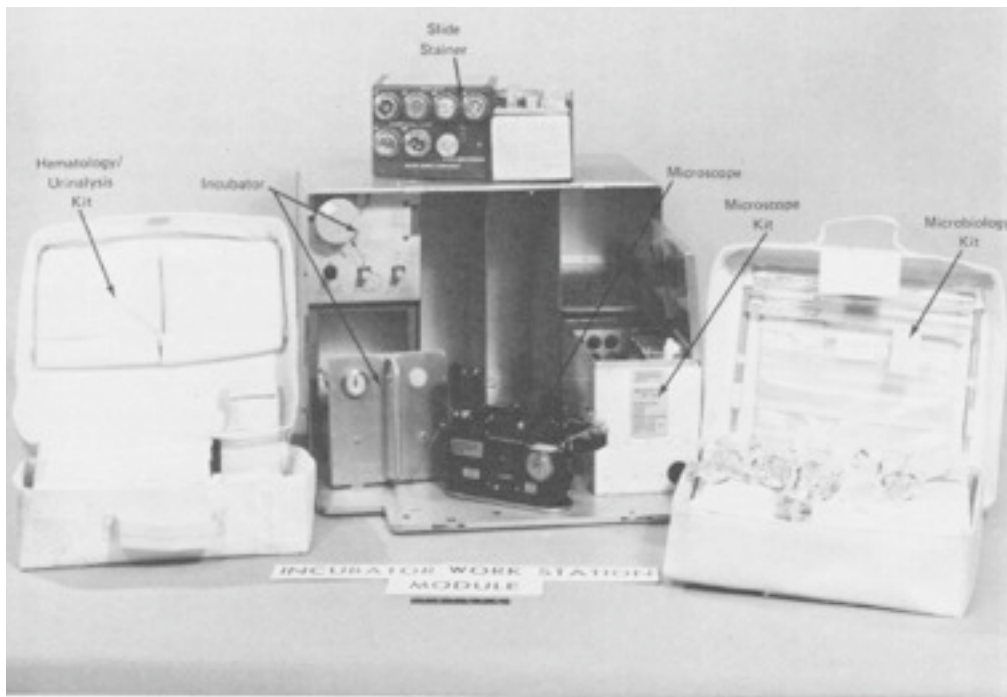

FIGURE A.H.a.-2.—Incubator Assembly. (Stowed in locker W708)

The Skylab Biology Workstation with Nikon model H in the centre. © NASA



The "Skylab Microscope" with camera attachment, being prepared at NASA. The same device being used in space. Pilot/Scientist Kerwin using the microscope in Skylab. © NASA

Description



A mint Nikon Model H, ready to use, with a slide on the stage

The Model H looks like it's been built inside a high end range-finder camera body and it does have that Leica M series feel. In fact, every single part of the microscope was purpose built, from its die cast body to its specifically designed objectives. There are only four plastic parts in the whole microscope: the body of the eyepiece, the door to the battery compartment, the on/off switch and the seldom seen black protection cap that slides over the objectives. The whole revolver head is attached to the body via two parallel steel blades that flex up and down for focusing. The die cast body and the solid prism running the whole length of the body make for most of the weight of the machine. The eyepiece is a standard 13.5mm diameter with an added thread so any eyepiece can be inserted inside the chromed tube. The tube itself unscrews in the same direction as the eyepiece and can be mistaken as being a part of it.



Bill Amos mentions a slot for filters but I haven't seen it on my microscopes or in any picture or Nikon literature. It might have been an addition to his late model which also seems to have an extra geared knob on its mechanical stage, something I haven't seen anywhere else either. It seems possible to drop a filter or stop inside the condenser itself which unscrews completely but it would be an inelegant solution and again, nothing in the Nikon documentation mentions such a use.

At about one kilo, the microscope is heavy and dense enough to be used on a table without risk of it tipping over. It does have a tripod thread on the bottom if extra stability is required. Nikon promised a special platform with a built-in transformer but never actually delivered it. To use it, you open the focusing lock, lift the mirror/condenser assembly, freeing the whole stage and slide in the black objective cover if your microscope still has one. You can now choose your objective with the front selector which is labelled 40 10 100 or 4 40 10. Two of the objectives look normal, if small, but the centre one is reversed so looks like it is used upside down. The 100x objective can be

swapped with the 4x and the selector knob lifts and turns to show the new numbers. A special screw-in compartment allows you to keep the spare objective in the microscope case when not in use. As the microscope is inverted, a prepared slide is put on the stage in an upside down position, with the cover slip at the bottom. Nikon recommends a .13 mm thick cover slip as part of the optical formula. There is no coarse focusing so the objectives always remain very close to the specimen. Particular care must be taken with the focusing lock which raises the whole head assembly so that the larger objectives protrude beyond the stage. Rotating the head while the focusing lock is on will make the objectives hit the slide if one has been left on the stage.

MICROSCOPE MODEL H

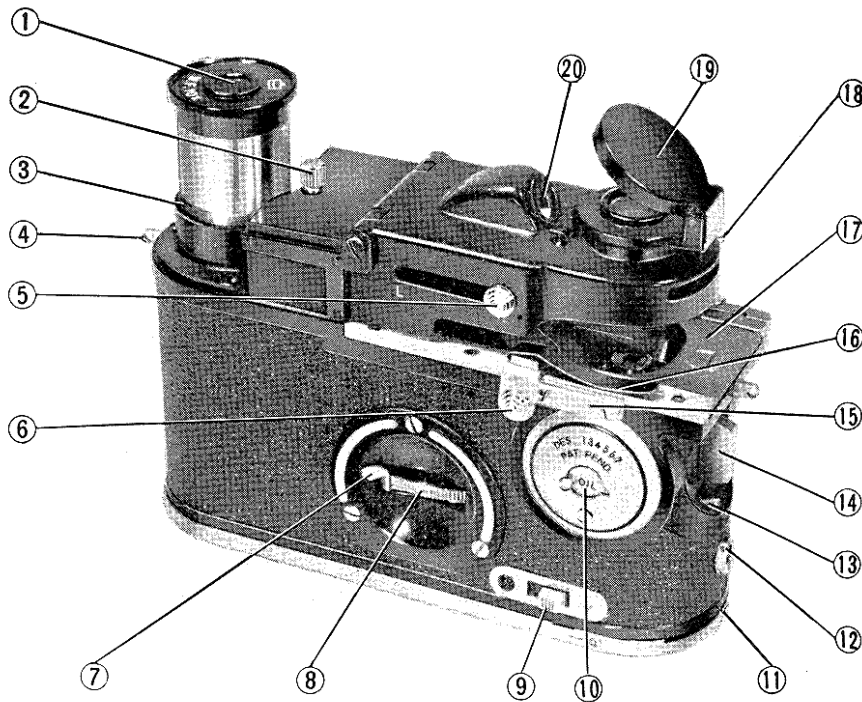
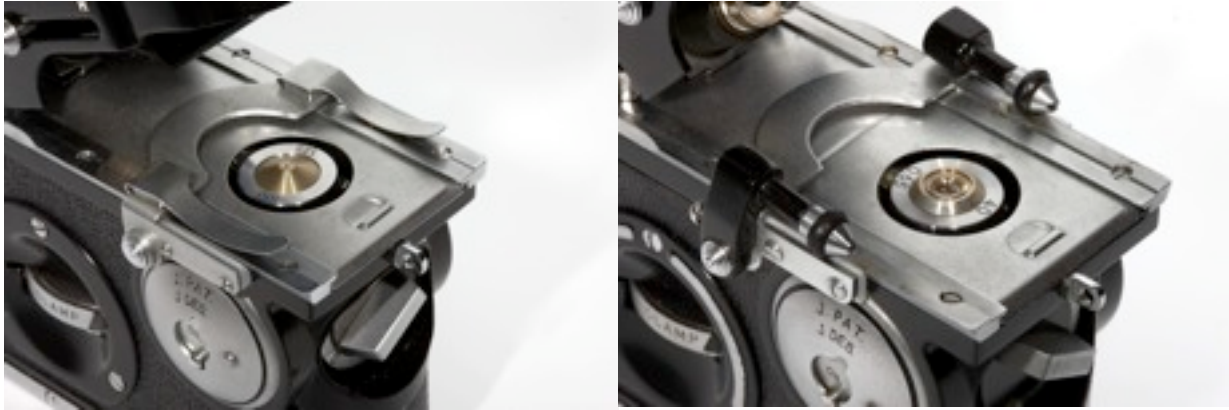

Fig. 1

- | | |
|------------------------------------------------------------------------|--------------------------------------------------------------------|
| 1. Eyepiece | 11. Variable resistor |
| 2. Battery housing cover locking screw | 12. Socket for 100 V. house current |
| 3. Screw thread for attaching Microflex (photomicrographic attachment) | 13. Objective magnification indicator (use a transformer—see p. 5) |
| 4. Eyelet for neck strap | 14. Objective nosepiece knob |
| 5. Condenser sliding knob | 15. Sliding stage |
| 6. Stage sliding knob | 16. Glass slide clip |
| 7. Fine focus locking screw | 17. Nosepiece cover |
| 8. Fine focus wheel | 18. Condenser diaphragm lever |
| 9. Electric illumination switch | 19. Reflecting mirror |
| 10. Oil opening | 20. Illuminating window |

A page from the original Nikon user's manual shows the main parts of the microscope. Being a picture of the earliest model, it differs from later ones in several points: the top of the eyepiece, the ring around the focus wheel, the slide clip, the illumination switch and the electric socket, which was never for "house current", but intended for 3 to 3.5 volts from an adapter. Some changes may have been cosmetic, other were obvious improvements, some just followed the availability of parts, like the power socket which is in fact a flash sync socket.



The stage itself uses one of two slide holders: the original metal clip and a more sophisticated spring loaded rubber rollers one. The first one has leather patches covering the inside of the springs to help smooth the slides lateral movement while the second has sprung wheels for the same effect. Both types of holders allow easy manipulations of the subject and reasonable scanning but neither is a true replacement for a mechanical stage.

When the slide is ready, you can swing down the condenser assembly. The illumination system consists of a rotating mirror which can be angled to catch available light or the output of a small built-in light bulb, a frosted glass diffuser, an iris with diaphragm, first lens and optional second lens. The large secondary lens slides on a tray between the condenser and the slide and helps focus the light at higher magnifications. In all the Model H I have seen, there is unfortunately no room for a filter or a dark field stop.

The whole manipulation is in fact quick and practical and can be done as well on a table as with the microscope hanging from one's neck. Hanging drop observations are more tricky but possible with the help of an optional long observation distance 40x objective. A special cavity slide allows for the manipulation of subjects during observation. That slide has a hole pierced through it and a cover slip glued at the bottom. Some were given as original accessories to the model H and they seem impossible to find nowadays but shouldn't be too difficult to make with plastic slides and a slide ringer. Modern well slides with a 1mm deep are not deep enough to be used hole side up.

Details

I have had to delve pretty deep into the innards of the Model H to repair and restore the shabbier of my samples. It makes one wonder about what drove Nikon to produce such a machine. There is always a demand for proper medical portable microscopes but it tends to be limited by very small budgets as their use is associated with charity work in developing countries or research related field work, neither being big budgets activities. Nikon in the 1950s was already very good with both cameras which involved a strong degree of miniaturisation and microscopes which meant a perfect understanding of the optics involved. Still, the Model H was a departure from both genres and necessitated many innovations. Of the standard McArthur microscope, the Model H retains the principle but innovates on almost everything else. Instead of a slider with objectives on it, the Model H has a proper revolving turret although of a completely exotic shape. Instead of being moved up and down a threaded barrel, the turret is suspended on parallel steel blades and pushed up by a spiral platform driven by the focus knob. With the focus locked, the whole assembly is pushed up to its stops to prevent it wobbling during transport. A screw and nut regulate the position of the

turret and is a sort of semi-permanent coarse focus. If you can't focus your Model H, this will be the first thing to check. The screw is accessed from the stage with a long thin screwdriver.

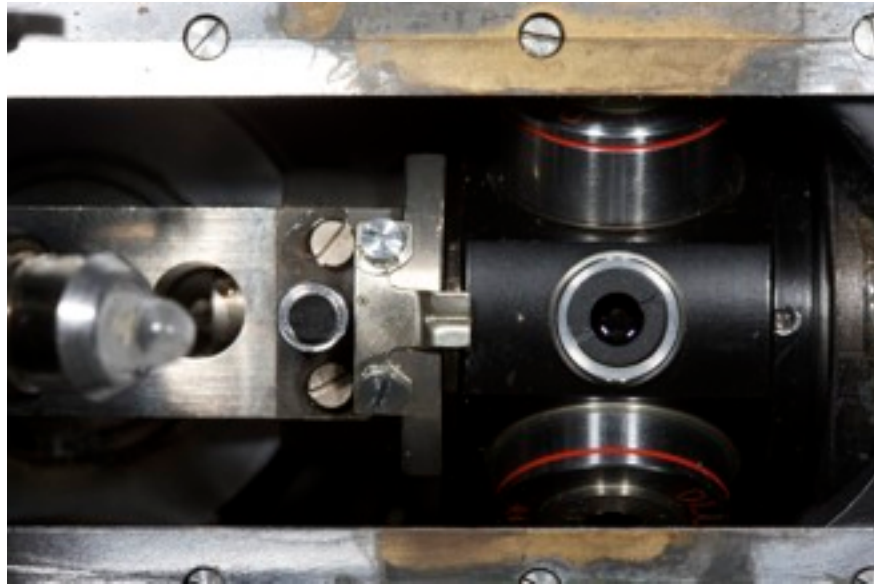

As a word of warning, it is essential for any work on a vintage camera to use exactly the right tools. Some screws and nuts will be very tight and even the best ones will be very soft and easy to damage. If your screwdriver doesn't have an exact fit, go buy another one. Only a very few online stores supply proper camera repair tools and many of the cheap tools found in DIY stores are woefully inadequate.

You might need to dismantle the whole assembly if, for example, the steel springs were bent by a fall or if any of the inaccessible internal screws is loose or missing. To do so, you will need to (carefully) peel the leatherette skin from both sides of the back of the microscope, eyepiece side. This uncovers four holes that go straight through the die cast body, through the battery compartment (take the batteries out) and give access to the four screws that hold the turret assembly.

In general, there is a lot that can be restored or fixed to keep the microscope functional even if it changes its appearance. One of my models was missing the objectives cover plate and after careful measurements, I had one machined out of aluminium. The usually missing black plastic cover can also be easily reproduced with a piece of 0.5mm thick plastic and a pair of scissors. A few parts however just cannot be replaced. The objectives, of course are irreplaceable and, in an inverted microscope, dangerously exposed. The eyepiece, being standard, is less critical, but it would be difficult to reproduce the important screw thread of the original. The extremely simple electrical circuit is also easy to work on if you can handle a soldering iron. The on/off switch can also be disassembled easily and, if dead, is a good candidate for an upgrade to a dimmer switch allowing one to regulate the amount of light produced. A simple variable resistance would do the job but more knowledgeable people might want to upgrade the whole system to rechargeable lithium ion batteries and a multi watt LED.

Accessories

Sold with the microscope were a hard leather case with a short and long strap, a special metal strap for the microscope itself and an oil dispenser for the 100x objective. A succinct A5 stapled manual was folded in two and inserted in the box. Supposedly, a few of the special well slides were also supplied and are mentioned in the manual but I haven't seen any and don't know how they

were packaged. Listed options were limited to the available objectives: 4x, 10x, 20x, 20x long distance, 40x and 100x for the bright field microscope.



The complete package, completely original.



The supplied oil dispenser, silica gel pack and light bulbs are all branded Nikon or Nippon Kogatsu. The hard backed leather case comes with a shoulder strap extension and the extra objective screw-in attachment shows its rarely seen plastic cover.



Another accessory that gets lost easily is the woven steel strap for the microscope itself. It is very strong but too slim to be comfortable.

Photography

Many of the photomicrography accessories that Nikon produced in the 1960s and 1970s will work on the Model H as they were mostly based on eyepiece projection. Adapter tubes such as the F mount Model II just screw on the chrome eyepiece tube and part of the assembly can be left there permanently. The very sophisticated Microflex, incorporating its own prism, lens, eyepiece and camera chamber was fantastically useful in its time but is overkill now that we have light digital reflex cameras with live view. Taking a picture with a compact camera using auto focus straight through the eyepiece yields surprisingly good results. Framing is slightly awkward though.



The Nikon F camera adapter - A Nikon F to Canon EOS adapter ring - The filter holder of the Nikon F camera adapter. Glass filters are just dropped in. Three different colours were supplied.

Phase Contrast

Nikon solved the difficult problem of a phase contrast option by turning it into a specific model. It was not a very flexible solution but allowed them to built a perfectly usable phase contrast microscope by factory aligning the stops and objectives. The more expensive Model HP has specific DL marked objectives with built in stops and the iris diaphragm is replaced by a sliding support with the two stops for the 20x and 40x objectives. The central position allows for bright field use.

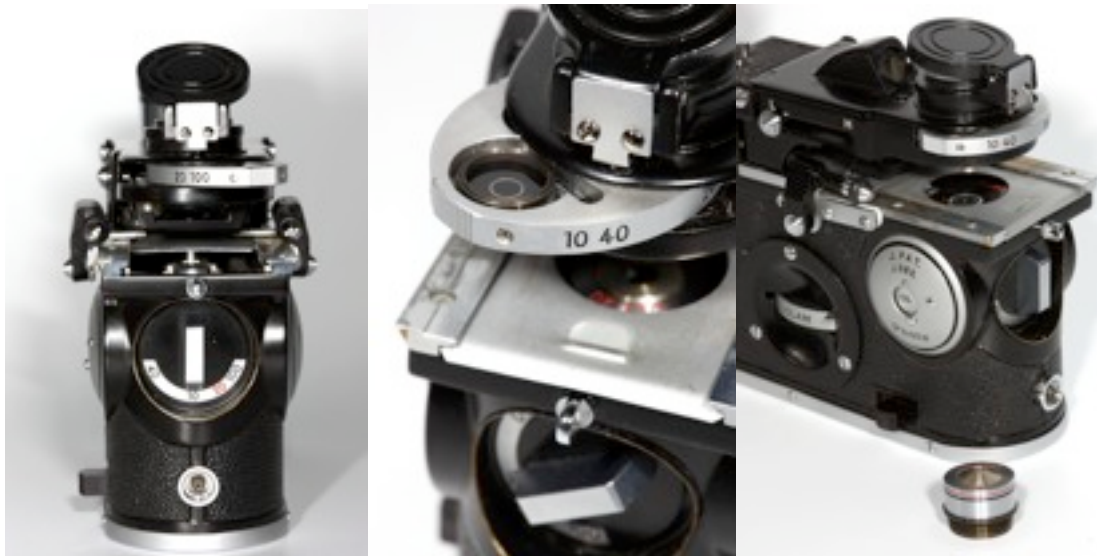

Phase Contrast compromises: the iris is gone replaced by a stop holder/selector. One of the two adjustment screws can be seen in the middle picture.



The 40x lens has its stop built-in while the 10x lens actually has a slip-on one that can be removed.



The 100x lens can be replaced by a DLL 20x shown added in red.
The selector pulls out and rotates to show the other, standard 4-40-10 option.

Modern day use

It is not often that you find a technical device that hasn't been bettered with time but, remarkably, if you are looking for the best portable microscope ever, you cannot find better than one manufactured forty years ago. The Model H could be made better nowadays, in particular with views to a better durability, but it couldn't be enhanced much. Some of the enhancements, as we will see, are actually feasible on the original microscope without altering its originality. The one area where the little microscope remains a bit weak is the built in lighting. It does get points for having one at all, something its modern counterparts are still struggling with, but sixties 3v light bulbs were never precise nor powerful. And their yellow light is not very useful either. Thankfully, you can now find LED based replacement bulbs that screw nicely in the same socket, are several times brighter, and have a much more focused beam of almost pure white light. All that while burning less electricity. Add to them a pair of Lithium AA batteries which have a 1.7 volts output rather than the anaemic 1.2 of standard alkalines and you get enough light to play with the whole range of the condenser's iris as well as do photography with.

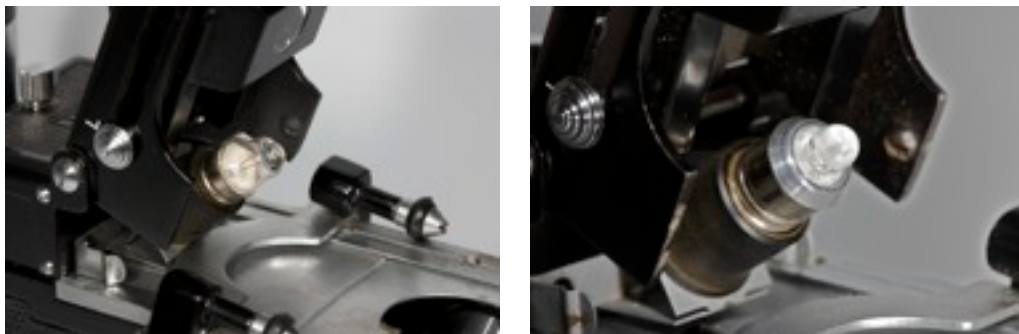

The illuminator with the original lightbulb, left and a modern white LED which fits right in, right.



Modern light bulb options from left to right. The Tektite L233 which is unsuitable as built to fit inside a reflector, the very good Tektite L222 and TerraLUX TLE-1S and a standard but not original incandescent light bulb.

Photography of course is the second item that benefited from 40 years of development. After trying several solutions, I found that the most compact and best quality adapter was still the original "F Camera Adapter Model 2" from Nikon. As with the microscope, it is only going to be found on eBay, but it, or other members of its family do pop up regularly. The special attachment is a tube made of several sections, one of which screws on top of the ocular. The rest of the tube, including the one lens, is removable and can stay attached to the camera. As its name implies, the tube has an F Mount for Nikon cameras but adapters can be added to attach other brands. I bought a very thin Canon EOS mount adapter for mine. The best thing about the whole system is that it makes it very easy to disconnect the camera, do all the set-up visually and then to re-attach the tube when a picture is needed. A camera capable of Live View, where the mirror is raised and the image is shown on the rear LCD screen rather than in the viewfinder, will allow for a very precise final focusing. I use a Canon 450D which was specifically chosen for the task as it is very light, has high resolution and features Live View. A number of other cameras, many Nikon included, will do but they should be kept light enough as the microscope itself only weighs 890g and will tip over if made top-heavy. If I am desperate for even more light, I use a little pocket torch which I shine into the mirror. Models from www.lummi.com are small enough to rest on top of the microscope and output up to 150 lumens for sub-second exposures. For photography, I have found that an added bonus of the EOS 450D was that its built-in flash could be shone directly into the condenser just by lifting the mirror.



The 1960s F camera adapter still works fine today and a camera's built in flash can be used for illumination without effort.

The last thing to benefit from third millennium technology is the case. While the original is extremely well built and protects the microscope adequately, it has no space for accessories and the hard rubber foam padding tends to disintegrate into dust over time. The camera-like dimensions of the model H make it very easy to find a modern case for it, from a nicely padded and secure hard shell Peli case to a more practical Lowepro camera bag. I chose a small Lowepro Digi 110 bag which gives the microscope a perfect fit and has a number of pockets for slides and accessories. I am now carefully choosing my next bag to include the photomicrography accessories, including the Canon 450D.



The Model H fits in camera bags easily. Most of the accessories will go into this tiny LowePro Digi 110.



The Model H and all its modern accessories, ready to explore the world.

Availability

While rare, the Model H microscopes are known to sell well and show up regularly in auctions and on eBay. If you can't find one in the Western world, it's worth having a look in Japan, remembering that the favourite auction site there is Yahoo. It is really worthwhile waiting for a "mint" microscope, hoping that the seller is truthful. They do show up as many of them were originally bought for very occasional use and they are no competition to a desktop microscope. The drawback to 1950s technology is that some parts in the microscopes will wear quickly and become beyond hope for repair. This is especially true of the Phase Contrast model which could easily be put out of alignment by wear and/or misuse. There is also the risk that somebody will have tried to clean the optics and scratched them and the odd chance, as I have found, that somebody not familiar with inverted microscopes will have tried to make his focus on a slide with the cover slip up.

Prices

The average price paid for a Model H over the last ten years is \$2,500 to \$3,000. The lowest price that I know of was \$1,800 and the highest ever asked for, for a model still new in its unopened box, is \$12,000. A German company spent months trying to sell a mint one on eBay for more than \$8000 unsuccessfully. They have tried again at different prices and it will be interesting to see if and how they finalise their transaction.

The most interesting thing about current prices is that they are not that expensive: a new Model H sold for the equivalent of \$450 in Yens in the early 1970s, the equivalent to above \$2,500 today. So their collector's status only offsets their second hand condition and if you find one in good condition, you will only be paying what a new one would cost today. Interestingly, the price rose to \$900 from 1973 to 1976 but that was only reflecting the inflation and wild foreign exchange fluctuations of the times rather than showing Nikon pricing itself out of the market.

Competition

The Model H co-existed with the original MacArthur microscope which was built by several companies. Those were very good and flexible and came with many accessories while never beating the model H as a fully developed product. Nowadays, the field is almost bare with only two equivalent portable microscopes still manufactured. Not having used any of them, I can only compare them on features (images © the manufacturers):

Model: **Swift FM-31**

Manufacturer: Swift Optical.



Status: Discontinued pending the late introduction of the FM-32

Magnification: 10x, 20x ocular, 10x, 20x, 40x objectives

Accessories: Mechanical stage, Light, Dark Field Stop

Pros: Less expensive at \$2,500 new, manufactured recently

Cons: Heavy, less elegant, less compact

Model: **Evolution Portable Scientific Field Microscope**

Manufacturer: unknown see distributors www.2spi.com and www.tedpella.com



Status: Still manufactured

Magnification: 10x eyepiece, 4x, 10x, 40x or 4x, P10x, P40x objectives

Accessories: Mechanical stage, 20x objective, W15x and W20x eyepiece, filters, polariser

Pros: Less expensive at \$1500, new, still manufactured, available as a Phase Contrast version.
Cons: Heavy, less elegant, less compact, possibly a copy of the FM31 or maybe the OEM version of the never released FM-32.

Model: **Omex Micromet**

Manufacturer: Omex Technologies, Northbrook, IL, USA.



Status: Still manufactured

Magnification: 10x, 20x ocular, 10x, 20x, 40x objectives

Size: 100(L)x100(H)x31(W), 2lbs

Accessories: Mechanical stage, Light, Dark Field Stop

Pros: Less expensive at about \$2,500 new, still manufactured, very flexible and configurable as an upright microscope as well.

Cons: less elegant, less compact

The "Millenium Health Microscope" is an project to design and produce an inexpensive but thoroughly modern field microscope for use in developing countries. Not unlike the "One Laptop Per Child" effort, it seeks funding for both the realisation of the microscope and its free distribution where needed. It is already at the stage of advanced prototype and the result is very interesting. www.millennium-microscope.org.

There are a handful of even more esoteric models which can be found occasionally such as rare original McArthurs but those would really need to be respected as the antiques they are rather than brought out in the field.

Gregory Guida / gregory.guida@gguida.com

I'll be happy to receive remarks and answer questions but also to hear of any other information you might have about the Nikon Model H. If you bought one when new, I would like to know where, for how much and which accessories were included and available at the time. If it was bought by yourself, your company or organisation for a specific task, I would like to know which one if possible. Thank you in advance.

The original reference for this article is:

Bill Amos 'Nikon Model H: The Ultimate Field Microscope', Micscape, July 1997.

URL <http://www.microscopy-uk.org.uk/mag/art97/nikonh.html>