

NEMESIS 9000™ SERIES



NEMESIS 9000™ Series Universal hardness tester



General information

NEMESIS 9000™ Series, represents the latest top of the range development on universal hardness testing by INNOVATEST®. Modern design, innovated technology, multi purpose hardness testing instrument, based on the application of precision mechatronic components and high resolution video machine vision systems. A superior level of precision combined with High Definition imaging creates an almost unlimited field of applications.

The NEMESIS 9000™ Series represents universal hardness testing, in the most versatile meaning of Universal. Aircraft engine parts, automobile parts, production lines, general quality assurance and laboratory use, are all fields covered by the NEMESIS 9000™ Series.

Manual operation or full scale automation to the highest possible level are both standard on NEMESIS 9000™.

NEMESIS 9000™, Load Cell, Closed loop, Force feedback system, to give what is due, in a modern way, with unlimited flexibility, suitable for the following:

OPTICAL HARDNESS TESTING METHODS:

- Vickers (HV), ISO 6507, ASTM E 92
- Knoop (HK) ISO 4545, 4546
- Brinell (HB) ISO 6506, ASTM E 10

DEPTH MEASURING HARDNESS TESTING METHODS:

- Rockwell (HR) ISO 6508, ASTM E 18
- Vickers depth measurement HVT VDI/VDE 2616-1
- Brinell depth measurement HBT VDI/VDE 2616-1
- Ball indentation hardness (H) (ISO 2039-1) (plastics)

Features

- Rockwell, Superficial Rockwell, Vickers, Knoop, Brinell, Ball indentation, HVT and HBT scales
- Superior range of testloads/force application ranging from 1kgf/9.8N to 3000kgf/29kN (over 3 models)
- Fixed workpiece position (no spindle)
- Descending test head with automatic workpiece detection
- Free definable, manual or motorized 6 position turret for objectives and indentors at choice
- High Definition INNOVAZOOM™ optical system for images of 0.7x to 1000x magnification
- PC based INNOVATEST IMPRESSIONS™ hardness testing firmware and database file system, standard
- Large, adjustable 15" industrial touch screen (or mouse with normal 22" LCD screen at choice)
- Automatic or manual focus, manual or fully automatic indent measurement, standard
- Built-in industrial SSD hard drives offer nearly endless file storing
- LAN, WLAN, USB-2, RS-232, Printer and DVI connectivity, standard
- On board built-in driver for (optional) motorized X-Y stage, standard
- Free definable test patterns case depth, traverse, free style, etc., optional
- Machine covers made of shock, damage and fire proof recyclable ABS
- Large range of optional accessories
- Large testpiece accommodation H=300mm, D=220mm

NEMESIS 9000™ has a rigid linear force actuator to move the test head in the required position. This can be done in 3 different ways. Automatic: the test head will decent to the workpiece after pressing the start button. Automatic workpiece position detection. The descending can also be realized in a manual high speed mode or in a manual "focus" mode.

NEMESIS 9000™ Series Universal hardness tester

6 Position turret, standard on NEMESIS 9000™

A special feature of the NEMESIS 9000™ is the motorized turret which comes as a standard on each system.

The turret can hold 3 different indentors and 3 objectives up to 40x magnification, or 6 different indentors on a PURE ROCKWELL model.

Combine the turret with an optional X-Y stage, a rotary table or inclination table and create the world's most comprehensive 4 or 5 axis hardness testing system.

Workpiece position is fixed. No handwheels, no difficult supporting and no spindle to carry heavy parts.

No wear and tear caused by heavy workpieces.

No workload and no additional drive systems required.



Protection, safety, online systems

NEMESIS 9000™ intelligent sensor systems will register any irregular or unusual force being applied to the turret, and will stop the test head from descending. In this way the system cannot cause injuries.

No significant force is applied when any of the objectives are in viewing position.

The NEMESIS 9000™ test head with force actuator, with or without turret, can be used in on-line structures or being integrated in to production lines requiring automatic testing procedures. The newly developed INNOVAZOOM™ optical system allows stunning, High Definition indent magnification (0.7x to 1000x). Refined algorithms guarantee for accurate automatic measurement.

Tester colors

The standard color of NEMESIS 9000™ "ABS" covers is "black". Your tester can be supplied in any color or paint structure of your choice.

INC-1LW
INC-2CGM
INC-3FR
INC-5ABL
INC-RAL XXXX

Laboratory White
Charcoal Grey Metallic
Ferrari Red
Atlantic Blue
Any RAL color on demand

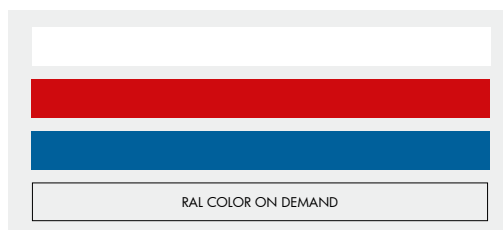

IMPRESSIONS™, Firmware

IMPRESSIONS™ is the advanced user operating system of the NEMESIS 9000™ Series. The software incorporates, manual and automatic measurement for all scales, image editing, file storing, image storing, report printing, turret operation, manual or automatic focusing and many other advanced functions.

The firmware converts to 3 different hardness (and tensile) scales simultaneously. The conversions can be set to material and standard (ISO/ASTM)

The system also controls an (optional) X-Y stage, rotary or inclining table that can be plugged into the standard built-in driver of the tester. No additional charges, no external devices.

In combination with an X-Y stage the tester offers the option of running case depth hardness programs, pre-defined testing patterns and/or other specific or special tasks defined by the user.

All data can be copied or exported in to MS applications like Word, Excel, or a report generator that emails test results directly to your workstation, or server. All data can be accessed over the LAN or WLAN connections.

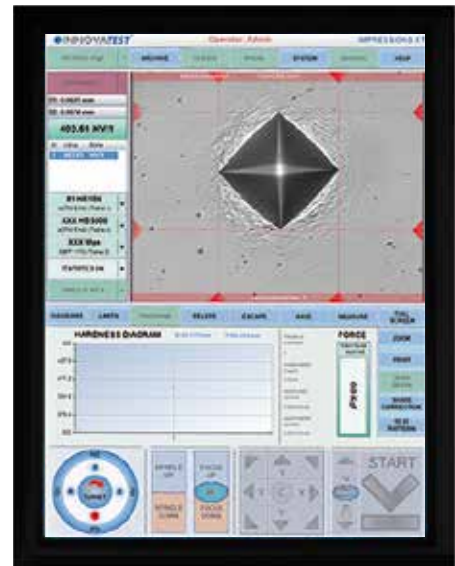

X-Y Stages, rotary tables, inclination devices

Being Universal means being ready for any task. NEMESIS 9000™ can be equipped with a variety of X-Y stages suitable for different applications. Different testforces require different specifications of the X-Y stages. Size, testload and positioning accuracy can be offered according to your particular requirement.

CNC rotary tables and inclining testing tables are available depending on the complexity of your workpieces.

X-Y Stages, rotary tables, inclination devices

Each NEMESIS 9000™ is supplied with a standard set of test anvils and worktables. Such set includes 1 V-groove anvil, 1 flat anvil 80mm, 1 large round testing table \varnothing 200mm. Additionally, you can opt for a large range of specific anvils such as a spot anvil, set of V-groove anvils tungsten alloy or diamond surface anvils.

The tester can be equipped with a furnace or cooling unit to test workpieces under high or low temperature. Robot workpiece loading and unloading can be supported by the built-in industrial computer.

To support large workpieces or cylinder blocks you can opt for the (350mm x 250mm) large working stage that incorporates T-grooves for solid workpiece fixing.

Flexible working heights

The NEMESIS 9000™ has a standard working height of 300mm. Ask our sales department for customized options.

Technical specifications

MODELS	NEMESIS 9001™ UNIVERSAL
SCALES/TEST LOADS/FORCE	
ROCKWELL, A, B, C, D, E, F, G, H, K, L, M, P, R, V	All scales
SUPERFICIAL ROCKWELL, N, T, X, Y	All scales
MACRO ROCKWELL HRM	Yes
VICKERS HV	1kgf/9.8N to 120kgf/1176N
KNOOP	1kgf/9.8N and 2kgf/19.6N
HVT	50kgf/490N, 100kgf/980.7N
BRINELL	1kgf/9.8N to 250kgf/2.45kN
HBT	Up to 250kgf/2.45kN
H (Ball indentation) (ISO 2039/1)	Yes
FORCE APPLICATION SYSTEM	
Linear force actuator	Standard
Load cell, closed loop, force feedback system	Standard
Motorized heavy duty TURRET with 6 positions	Standard
Indenter positions	3
Objective positions	3
LED optical indent illumination	Standard
LED ring light indent illumination	Standard
OPTICAL MEASURING SYSTEM	
5 mega pixels optical ZOOM system	Standard
Auto focus	Standard
Manual focus	Standard
Fully automatic indent measuring	Standard
Manual on screen indent measuring	Standard
Zoom and magnification ratio	0.7x to 1000x
Dual view™ working area overview camera	Optional
External Electronic Brinell microscope and objectives	No
DEPTH MEASUREMENT SYSTEM	
Heidenhain™ high resolution optical system	Standard
HARDWARE AND USER INTERFACE	
Embedded micro industrial PC and SSD harddrives (RAID1)	Standard
Adjustable 15" full color industrial touch screen	Standard
MS Windows® Ultimate license	Standard
IMPRESSIONS™ hardness testing firmware	Standard
Automatic image and file storage	Standard
Stores and handles 3000 files and images	Standard
Stores and handles 9000 files and images	Optional
Forms™ set of customized certificates	Optional
Universal motorized X-Y stage controls	Standard
CONNECTIVITY	
External digital (DVI) TFT screen output	Standard
External keyboard and mouse connections	Standard
LAN (local area network connection)	Standard
WLAN (Wireless network connection)	Standard
Bi-directional RS-232	Standard
Printer/USB-2 output	Standard
Built-in motorized X-Y stage driver	Standard

**NEMESIS 9002™
UNIVERSAL**

3kgf to 750kgf

All scales

All scales

Yes

3kgf/29N to 120kgf/1176N

No

50kgf/490N, 100kgf/980.7N

3kgf/29N to 750kgf/7.35kN

Up to 750kgf/7.35kN

No

Standard

Standard

Standard

3

3

Standard

Standard

Standard

Standard

Standard

Standard

Standard

0.7x to 1000x

Optional

No

Standard

Standard

Standard

Standard

Standard

Standard

Standard

Standard

Standard

Standard

Standard

Standard

Standard

Standard

Standard

Standard

Standard

**NEMESIS 9003™
UNIVERSAL**

10kgf to 3000kgf

All scales

No

Yes

10kgf/98N to 120kgf/1176N

No

50kgf/490N, 100kgf/980.7N

10kgf /98N to 3000kgf/29kN

Up to 3000kgf/29kN

No

Standard

Standard

Standard

3

3

Standard

Standard

Standard

Standard

Standard

Standard

Standard

0.7x to 1000x

Optional

No

Standard

Standard

Standard

Standard

Standard

Standard

Standard

Standard

Standard

Standard

Standard

Standard

Standard

Standard

Standard

Standard

Standard

Technical specifications

NEMESIS 9000™	
Hardness resolution	0.01 Rockwell, 0.1 Vickers, 1 Brinell
Objectives	3 installed for 0.7x to 1000x
Test loads	1kgf/9.8N, 2kgf/19N, 2.5kgf/24N, 3kgf/29N, 4kgf/39.2N, 5kgf/49N, 6.25kgf/62N, 10kgf/98N, 15.625kgf/153N, 20kgf/196N, 25kgf/245N, 30kgf/294.2N, 31.25kgf/306N, 50kgf/490N, 62.5kgf/612N, 100kgf/980.7N, 120kgf/1176N, 125kgf/1225N, 187.5kgf/1838N, 250kgf/2.45kN, 500kgf/4.9kN, 750kgf/7.35kN, 1000kgf/9.8kN, 1500kgf/14.7kN, 3000kgf/29kN
Rockwell test scales	A, B, C, D, E, F, G, H, K, L, M, P, R, S, V, 15N, 30N, 45N, 15T, 30T, 45T, 15W, 30W, 45W, 15X, 30X, 45X, 15Y, 30Y, 45Y, HRM
Vickers test range	HV: 1kgf/9.8N, 2kgf/19N, 3kgf/29N, 4kgf/39.2N, 5kgf/49N, 10kgf/98N, 20kgf/196N, 30kgf/294.2N, 50kgf/490N, 100kgf/980.7N, 120kgf/1176N HVT: 50kgf/490N, 100kgf/980.7N
Brinell test range	HB1: 1kgf/9.8N, 2.5kgf/24N, 5kgf/49N, 10kgf/98N, 30kgf/294.2N HB2.5: 6.25kgf/62N, 15.625kgf/153N, 31.25kgf/306N, 62.5kgf/612N, 187.5kgf/1838N HB5: 25kgf/245N, 62.5kgf/612N, 125kgf/1225N, 250kgf/2.45kN, 750kgf/7.35kN HB10: 100kgf/980.7N, 250kgf/2.45kN, 500kgf/4.9kN, 750kgf/7.35kN, 1000kgf/9.8kN, 1500kgf/14.7kN, 3000kgf/29kN HBT: 5kgf/49N, 250kgf/2.45kN
Indentors (optional)	Brinell Balls: 1mm, 2.5mm, 5mm, 10mm Vickers Diamond: 136° Rockwell Diamond Cone: 120° Rockwell balls: 1/16", 1/8", 1/4", 1/2"
Workpiece accommodation	Vertical capacity 300mm (opt. 500mm), Horizontal capacity 220mm (from center-line)
Standards	Meets or exceeds, ISO, ASTM, JIS (Nadcap) standards
Force tolerance	Max. < 1%
Force control	1 - 99 seconds
Tester color (standard)	Black/Metallic silver
Light source	White power LED (Opt. green/blue/red)
Operating temperature	10°C to 35°C, non-condensing
Machine dimensions	400mm x 650mm x 1440mm (WxDxH)
Machine weight	242kg
Power consumption	1 Amp
Power supply	100V AC to 240V AC, 50Hz/60Hz, single phase

Standard delivery

- Flat anvil, hardened, $\varnothing 80\text{mm}$
- V-anvil, hardened, $\varnothing 80\text{mm}$
- Testing table, hardened, $\varnothing 200\text{mm}$
- Wireless mouse and keyboard
- Power cable
- Four adjustable feet
- INNOVATEST® certificate
- Installation and user manual

Optional accessories

- Certified indentors (ASTM, DIN, ISO)
- Certified reference hardness blocks (ASTM, DIN, ISO)
- Large testing table, 350mm x 250mm, with T-grooves
- Extra large testing table, 450mm x 350mm, with grooves and support
- Long bar supports, to ease testing long bars
- Motorized X-Y stages, motorized rotary or tilting tables
- Built-in 5 axis support driver
- Solid tester table and storage cabinet



Order details

NEMESIS 9001™

Video based Universal hardness tester, test forces 1kgf/9.8N to 250kgf/2.45kN

NEMESIS 9002™

Video based Universal hardness tester, test forces 3kgf/29.4N to 750kgf/7.35kN

NEMESIS 9003™

Video based Universal hardness tester, test forces 10kgf/98N to 3000kgf/29kN

Technical drawing NEMESIS 9000™

All dimensions are in mm

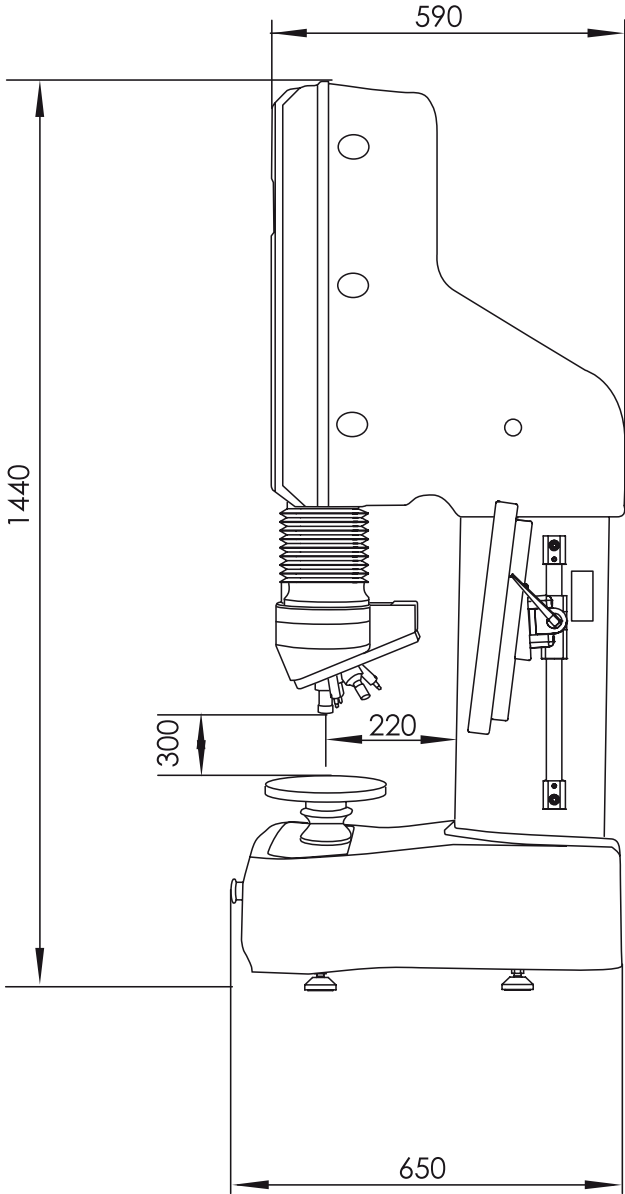

All dimensions are in mm

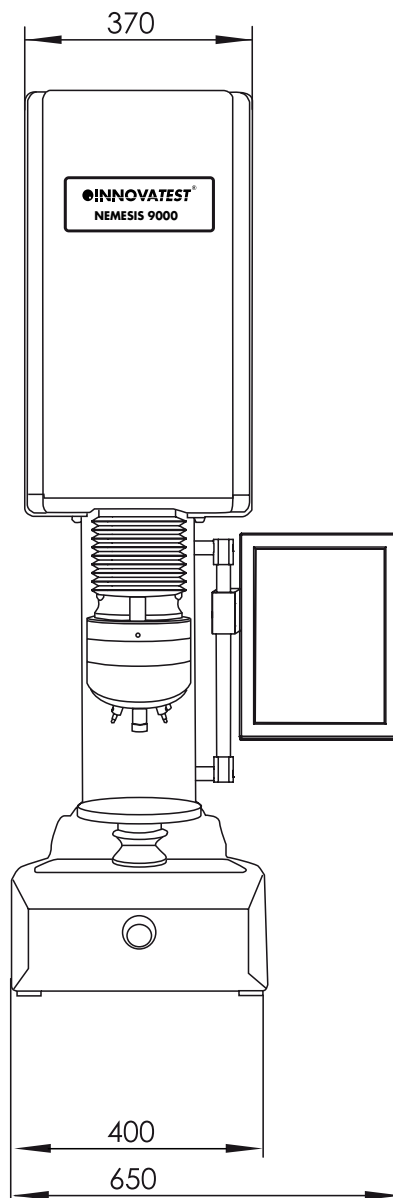

Represented by:

IN12-156 080615

CORPORATE HEAD OFFICE

INNOVATEST Europe BV **MANUFACTURING, DISTRIBUTION & SERVICE**

Borgharenweg 140
6222 AA Maastricht (The Netherlands)
Phone: +31 43 3520060
Fax: +31 43 3631168
E-mail: info@innovatest-europe.com
Website: www.innovatest-europe.com

BRANCHE OFFICES

INNOVATEST Benelux BVBA **SALES & SERVICE**

Phone: +32 12 779002
Fax: +32 12 779003
E-mail: info@innovatest-benelux.com
Website: www.innovatest-europe.com

INNOVATEST Shanghai Co., Ltd. **ASIA & CHINA SALES & SERVICE**

Building 2, No.123, 1165 Nong Jindu Road,
South Metropolis Industrial Park
Minhang District, Shanghai, P.R. China
Zip code: 201108
E-mail: info@innovatest-shanghai.com
Website: www.innovatest-shanghai.com

Changes in products and/or product specifications can emerge due to new technologies and continuous development.

We reserve the right to change or modify specifications of products without prior notice.

We recommend you to contact our sales office for up-to-date information.

© All rights reserved