

GMG 6

DJ System HYghYr

Users Manual

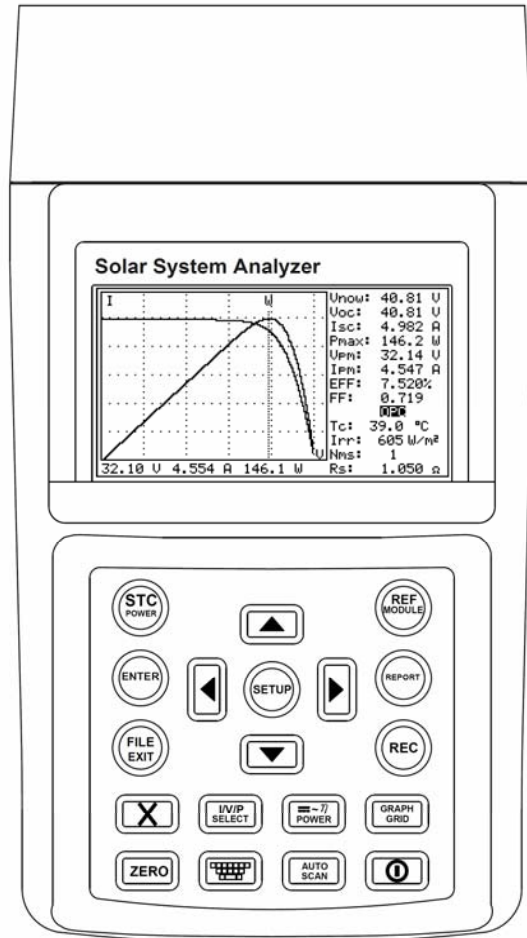

This unit (excluding Irradiance Meter) passes the following tests:



EN 61010-1: 2010
EN 61010-2-030: 2010
CAT II 1000V, CAT III 300V
Pollution Degree 2



EN61326-1: 2006 Class B
(CISPR 11: 2009/A1: 2010 Group 1 Class B,
EN 61326-1: 2006, IEC 61000-4-2: 2008,
IEC 61000-4-3: 2006+A1:2007+A2:2010,
IEC 61000-4-8: 2009)

Safety Symbols

 **WARNING**

Please read the statement thoroughly to prevent injury or loss of life, and prevent damage to this product.



Earth (ground)



DC (Direct Current)



Conforms to relevant European Union directives.



Do not dispose of this instrument as unsorted municipal waste. Contact a qualified recycler for disposal.

Caution:



1. The ventilation openings on the unit should not be blocked.
2. Please pay attention to polarity of DC input, follow the polarity info by the input jack.



Caution, Risk of Electric Shock.



This equipment is not for measurements performed for CAT IV.



Please remove all the test leads before performing maintenance, cleaning, battery replacement, fuse replacement, etc.



Do Not plug in the AC adapter when the ambient temperature exceeds 45°C / 113°F.



Do Not charge the lithium battery when the ambient temperature exceeds 45°C / 113°F.

Table of Contents

I. Preparation	1
II. Features	2
III. Panel Description	4
A. Solar system analyzer	4
B. Irradiance Meter (with Thermometer)	11
IV. Operation	12
A. Connecting Diagram	13
B. AUTO SCAN	19
C. REPORT	23
D. FILE LIST	25
E. REF MODULE	27
F. SOFTWARE KEYBOARD	29
G. ZERO Calibration	30
H. Data Logging	31
I. Clear Recorded (File) Data and Restore Defaults	33
J. SETUP Parameters	34
K. THERMOMETER Setup	36
L. POWER Mode	37
V. Application Notes	44
A. Quality Control at Production Line, Warehouse, or Site of Installation	44
B. Identify Requirements of Solar Power System	45
C. Maintenance of Solar Panels	46
D. Verify the Best Installation Angles of Solar Panels	48

Table of Contents

VI. Specifications	49
A. Electrical Specifications	49
B. General Specifications	53
VII. Battery Replacement (Recharging)	56
VIII. Fuse Replacement	58
IX. Maintenance & Cleaning	59

I. Preparation

This Solar system analyzer uses a rechargeable lithium battery.

Before using the new rechargeable lithium battery, please charge it for 10~12 hours continuously for better battery life.

The rechargeable lithium battery is pre-installed in the solar system analyzer at the factory.

Users can plug in the AC adaptor and no need to turn on the Analyzer. Then the rechargeable lithium battery is charged automatically.

II. Features

- **I-V curve test** for solar system
- Max. solar system power (P_{max}) search by Auto-scan:
1000V, 12A (12000W capability)
- **Intelligent test logic** with no personnel attendance required in the field. Solar system analyzer waits and tests the system until appropriate sunlight irradiance is detected.
- Max. voltage (**V_{pm}**) at P_{max}
- Max. current (**I_{pm}**) at P_{max}
- Voltage at open circuit (**V_{oc}**)
- Current at short circuit (**I_{sc}**)
- **Efficiency (%)** calculation of solar system
- **Temperature** measurement of solar panels
- **Irradiance** measurement of sun light
- **Series resistance** (R_s) calculation of solar panels
- **I-V curve with cursor** to display each data point
- With **data logging/open** function, the I-V curves of solar system can be analyzed/recorded for a period of time (e.g. 60 min.)
- Conversion of I-V curve under OPC to data under standard test condition (STC) based upon **IEC standard**
- Provide OPerating Condition (**OPC**) and Standard Test Condition (**STC**) test reports for verification of solar panel performance (**OK**, or **NO OK**)
- Users can set up the **parameters** of solar panels
- Users can set up the **series number** of solar panels. Parameters of many solar panels can be measured in one measurement.
- Built-in **calendar clock**







- AC power adaptor
- Rechargeable lithium battery, low battery warning
- Optical **USB** cable for PC
- With optional power clamps (**SOLAR 15** DC Current Probe and **SOLAR 21** AC Power Clamp), continuously **measure/monitor/record** the **DC power** output of solar system and the **AC power** output of inverter (1 phase or balanced 3 phases); calculate the efficiency of **DC to AC power conversion** and the efficiency of the **max. output power**

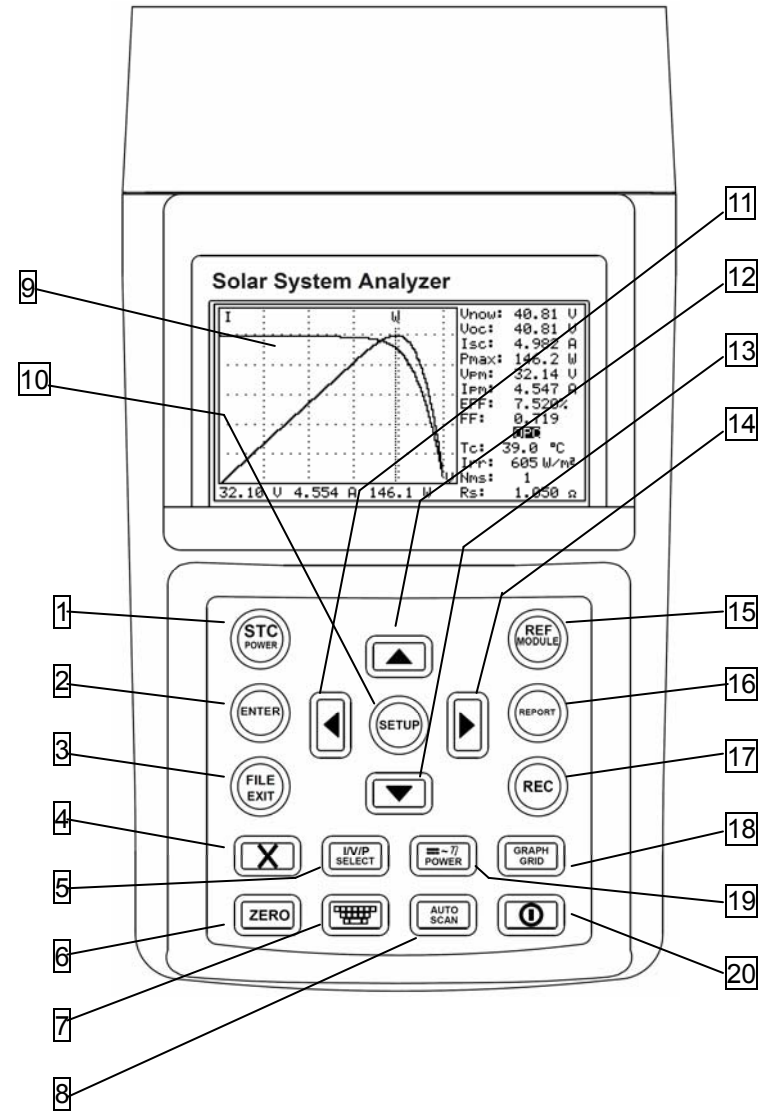





III. Panel Description

A. PV system tester

A-1 FRONT PANEL



1.  **STC POWER button**
Press this button to switch the display to STC or OPC curves;
or press it to enter POWER mode.
2.  **ENTER button**
(In the FILE LIST) Press this button to open a chosen file (REC file or
Mod file).
3.  **FILE EXIT button**
Press this button to display File List. Press it again to exit File List.
4.  **DELETE button**
(In the FILE LIST) Press this button to delete the data of a chosen file.
5.  **I/V/P SELECT button**
Select I-V curves or P-V curves, or display both.
6.  **ZERO button**
For Zero calibration and Timer reset. Connect two testing clips with
each other and press this button, the zero calibration of voltage and
current will be performed. Regular calibration of zero would maintain
the accuracy of the instruments. Under POWER mode, press this
button to reset the Timer and curve drawings.
7.  **SOFTWARE KEYBOARD button**
Press this button to display or conceal the SOFTWARE KEYBOARD
which be used to type in characters.

8.  **AUTO SCAN button**
Auto scan I-V curve test. Press this button for 2 sec. to perform the
auto scan of intelligent test logic.
9. **LCD**
LCD displays measurement data and curves.
10.  **SETUP button**
Enter/Exit (parameter) SETUP menu.
11.  **button**
(1) In a curve, press it to move the cursor left.
(2) In SETUP menu or REF MODULE function or FILE LIST, press it to
decrement value by 1 or display the file of previous page.
12.  **button**
In "SETUP menu" or "REF MODULE function" or "File List", press ▲
button to select the previous item or file.
13.  **button**
In "SETUP menu" or "REF MODULE function" or "File List", press ▼
button to select the next item or file.
14.  **button**
(1) In a curve, press it to move the cursor right.
(2) In SETUP menu or REF MODULE function or FILE LIST, press it to
increment value by 1 or display the file of next page.

15.  **REF MODULE button**

Enter/Exit the editing function of solar panel parameters.

16.  **REPORT button**

Press this button to display Standard Test Condition (STC) report and Operating Condition (OPC) report.

17.  **REC button**

- (1) Press this button to start data logging. Press it again to stop data logging.
- (2) How to clear recorded data: keep pressing REC button and turn on the Analyzer, then all the data recorded in the Analyzer will be completely deleted. And the factory defaults will be restored.

18.  **GRAPH GRID button**

Press this button to select “Display” or “Cancel” graph grid.

19.  **DC graph/ AC graph/ Efficiency button**

Press this button to display “DC power graph” or “AC power graph” or “Efficiency”.

20.  **Power button**

Turn on/off the power of the Analyzer.

A-2 REAR PANEL

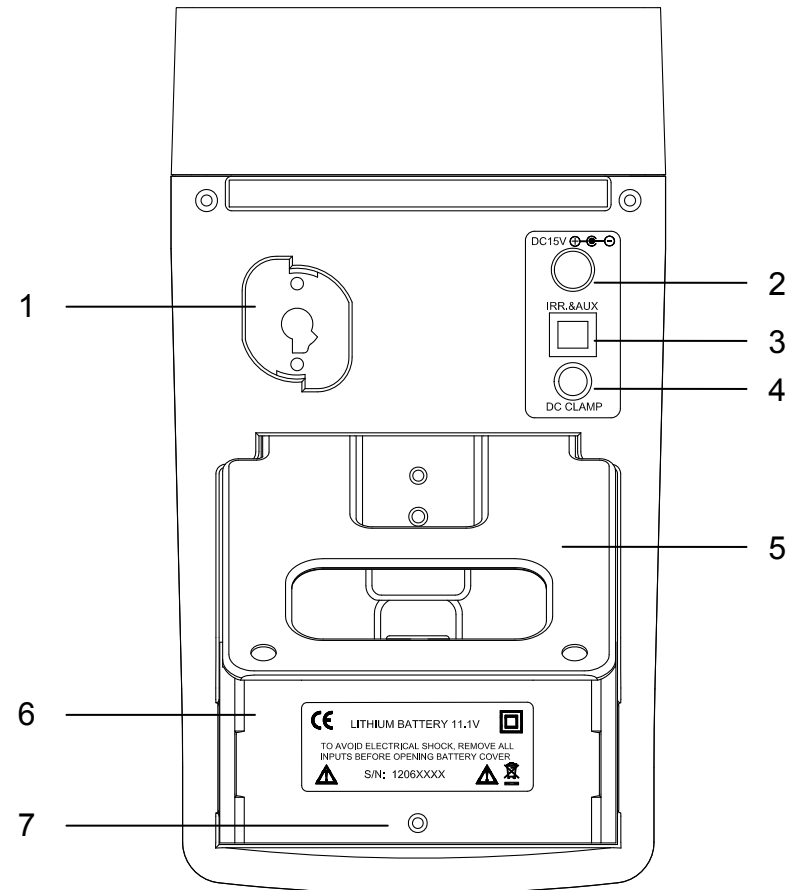

1. Communication window:

- (1) Connecting the Analyzer with PC via USB cable.
- (2) Or under POWER mode, connecting the Analyzer with the communication cable of **Solar 21** AC Power Clamp.

2. AC to DC adaptor input.

- 3. Terminal for connecting Irradiance meter
- 4. Terminal for connecting Solar 15 DC Current Probe
- 5. Stand
- 6. Battery cover
- 7. Screw of battery cover

Note:

 When the Analyzer is under POWER mode, the PC Application Software can not communicate with the Analyzer.

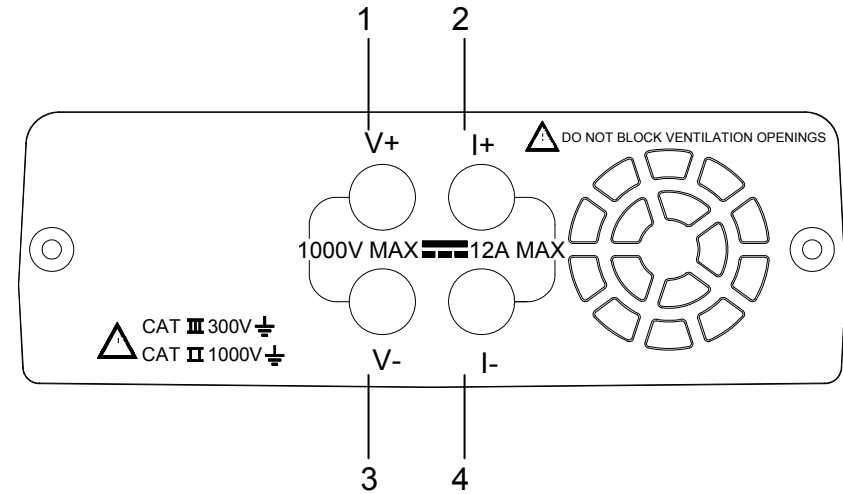
A-3 TOP PANEL

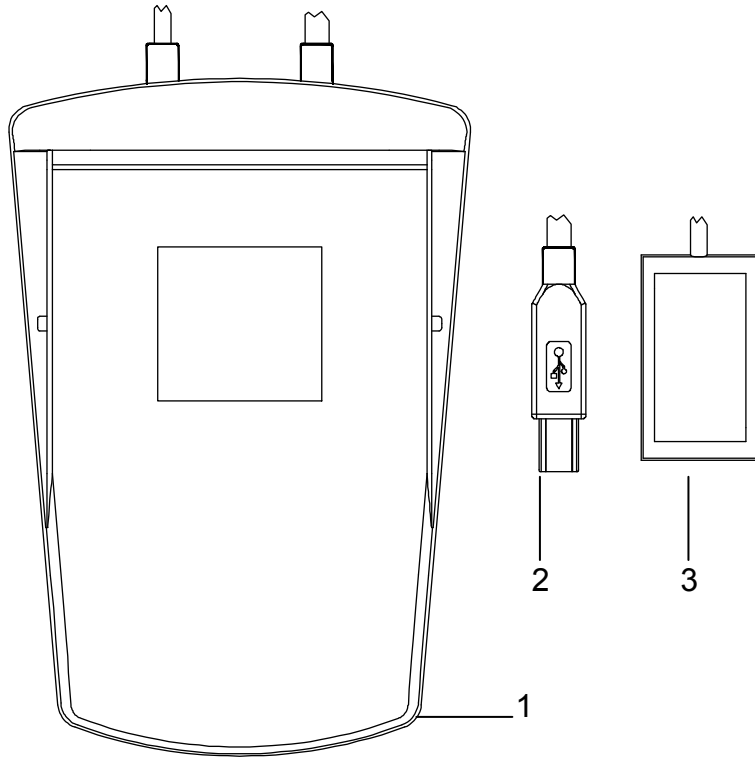

- 1. V+ terminal
- 2. I+ terminal
- 3. V- terminal
- 4. I- terminal

B. Irradiance Meter (with Thermometer)



1. Box for Irradiance meter.
2. Connecting terminal of Irradiance meter.
3. Auxiliary Thermometer.



Note: Apply Thermal conductive gel on the metal part of Auxiliary thermometer, then stick it on solar panel (back side) to detect the temperature of solar panel. And Thermal conductive gel can be removed easily.

IV. Operation



Warning: To avoid risk of electric shock and damage to the unit, do not touch any internal components with tools of any kind through the ventilation opening.



Warning: AC adaptor is used for lithium battery recharging only. The power source of the Solar System Analyzer is always the (rechargeable) lithium battery, NOT AC adaptor.



Warning: When using a lithium battery as the power source, please do not plug in an AC adaptor. If users plug in an AC adaptor during operation, power to the analyzer will be interrupted and the data during operation will be lost.



Note: When pressing any button, users will hear a sound of buzzer. When keeping pressing it for more than 2 seconds, users will hear another sound of buzzer. This status is normal.

A. Connecting Diagram

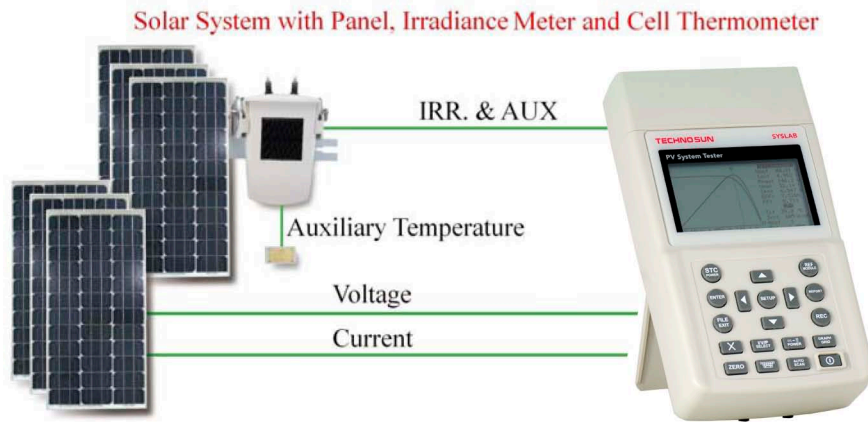

Two Wire Measurement

With the “4-wire to 2-wire connecting cable”, users only need 2 testing clips which must touch the metal parts of the output terminals of a solar panel.

The “4-wire to 2-wire connecting cable” can convert four wire measurement to two wire measurement. First, plug the 4-wire testing cable into Analyzer’s 4 terminals (black to black, red to red), and connect its other side with “4-wire to 2-wire connecting cable”. And then connect “4-wire to 2-wire connecting cable” with 2 testing clips (black & red).

Solar (DC) System

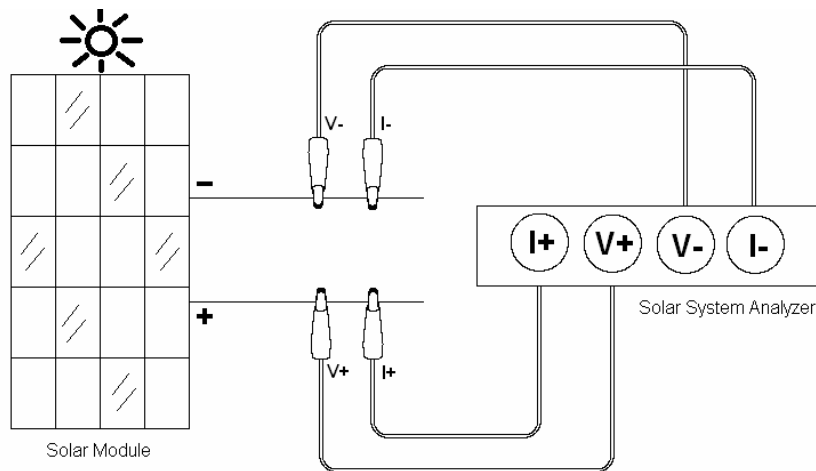

4-wire Testing Clips Connecting Diagram





4-wire to 2-wire Connecting Cable

Then two wire measurement will be performed by using 2 testing clips which touch the metal parts of the output terminals of a solar panel (see below).



Four Wire Measurement (with 2 optional testing clips)

All 4 testing clips must touch the metal parts of the output terminals of a solar panel.

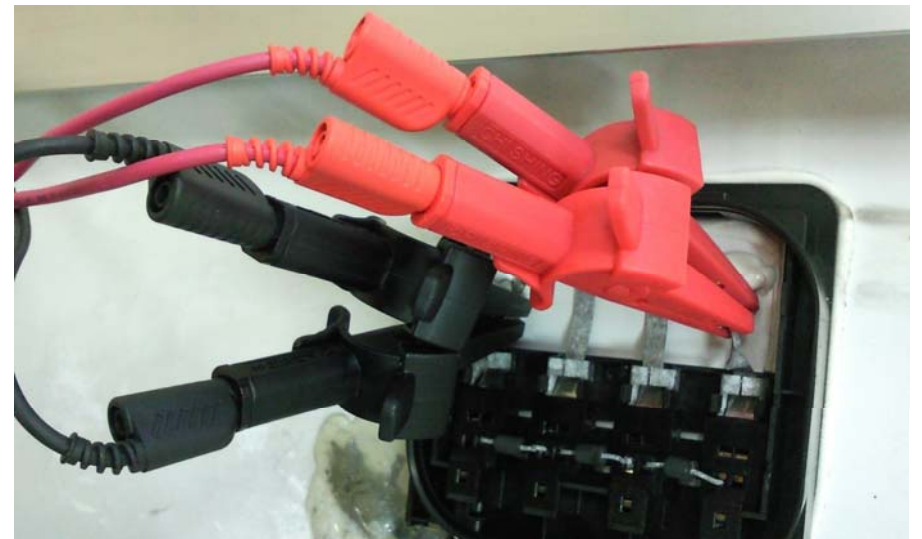



Connect the Solar panel (front side) with Irradiance meter





Connect Analyzer with Irradiance meter





Use Thermal conductive gel to stick Auxiliary thermometer on the Solar panel (back side)

B. AUTO SCAN

- Put solar panel(s) under sunlight to let the light source illuminate on solar panel(s) uniformly.
- Connect Irradiance meter with Analyzer.
- Properly connect testing clips to solar panel and Analyzer. The red clip is for positive pole and the black clip for negative pole. (refer to above Connecting Diagram).
- Press  button to turn on Analyzer.
- Press  (**AUTO SCAN**) button to perform Auto-scan. After the scanning is finished, the OPC measurement result will display like below.
- Analyzer will automatically measure:
 - Voc:** Voltage at open circuit.
 - Isc:** Current at short circuit.
 - Pmax:** Max. solar system power.
 - Vpm:** Max. voltage at Pmax.
 - Ipm:** Max. current at Pmax.
 - EFF:** Efficiency of solar panel.
 - FF:** Fill Factor.
 - Tc:** Temperature.
 - Irr:** Irradiance.
 - Rs:** Series resistance.

Based upon above parameters, Analyzer will scan again to draw two curves on LCD: the 1st one is I-V curve; the 2nd one is P-V curve.

- Users can Press  or  button to move the cursor along the curve to view the values (voltage/current/power) of each point. (The values will display below the curve.)
- Users can press **STC POWER** button to switch the display to STC values/curves; press **STC POWER** button again to switch the display to OPC values/curves. But if Irr shows "----", STC values/curves can not be displayed.

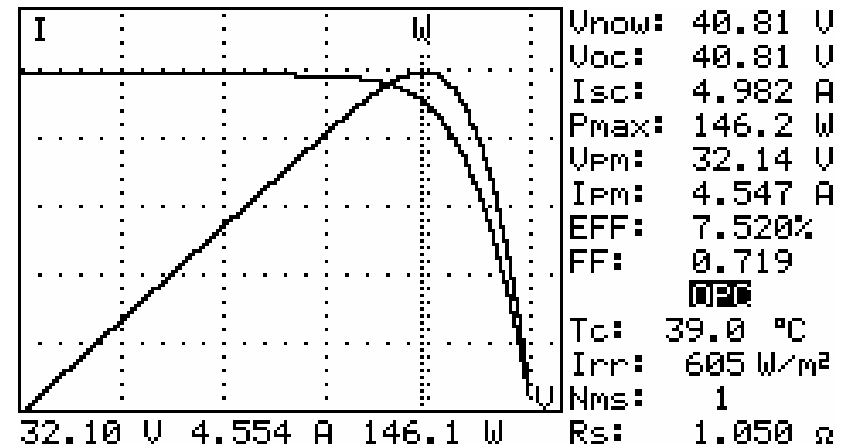

Note:



- The display of STC values/curves is based on the calculation of solar panel parameters. In order to get correct STC values/curves, first users have to nominate a Mod file in the FILE LIST as the solar panel parameters
- After turn on the power of Analyzer, if Irr shows "----" then please turn on the Analyzer again to let Irr shows normal values.
- When the display shows STC values/curves: the values are STC

values but the curves are OPC curves.

4. For both OPC and STC, the calculation of solar panel efficiency (EFF) is based on Irradiance = 1000 W/m^2 .
5. When Irr shows "----", it means the Irradiance meter can not be detected or the measured irradiance is over the spec.
6. If the display shows "OL" in OPC or STC values/curves, it means the values of this measurement are not accurate.
7. If there is a "*" symbol next to Rs, it means the Rs value is from the irradiance calculation. If there is no symbol, it means the Rs value is from the calculation of loading voltage and current.
8. When Isc is over 12A, AUTO SCAN can not be performed.
9. When there is a Low battery warning, AUTO SCAN can not be performed automatically.

AUTO SCAN of Intelligent Test Logic

This Analyzer can perform the AUTO SCAN of intelligent test logic to get a more accurate Pmax. The Analyzer will wait till the irradiance is over 800 W/m^2 , then it starts AUTO SCAN. And it will continuously AUTO SCAN 5 times, then find out the best Pmax.

1. Put solar panel(s) under sunlight to let the light source illuminate on solar panel(s) uniformly.
2. Connect Irradiance meter with Analyzer.
3. Properly connect testing clips to solar panel and Analyzer. The red clip is for positive pole and the black clip for negative pole. (refer to above Connecting Diagram).
4. Press  button to turn on Analyzer.
5. Press  (**AUTO SCAN**) button for 2 sec. to perform AUTO SCAN of intelligent test logic. After the scanning is finished, the best OPC measurement result will be displayed.
6. If the irradiance can not be over 800 W/m^2 which makes AUTO SCAN can not be performed, users can press  (**DELETE**) button to perform AUTO SCAN 5 times based on the current irradiance. After the scanning is finished, the best OPC measurement result will be displayed.

C. REPORT

1. After AUTO SCAN finished and curves displayed, or after open a REC



file under FILE LIST, press  (REPORT) button to display test report like below: it shows NOMINAL parameters, OPC / STC report. But if Irr shows "-----", the report can not be displayed.

2. In the report:

Delta Irrad represents the irradiance variation volume during AUTO SCAN process. If this value is bigger, it may cause an abnormal I-V curve.







Irr < 800 W/m² means the irradiance is small than 800 W/m².

Pmax @ STC: if OK it represents the Pmax of STC meets the Pmax spec. of solar panel parameters; if NO OK it means the Pmax of STC do not meet the Pmax spec. of solar panel parameters.

3. Users can press  button to switch the display shows STC report, or OPC report (Nms = Nms of solar panel parameters) or OPC report (Nms=1). Press  button to switch the display in reverse order.

Test Report		
Delta Irrad:	0W/m ²	2012/05/01 12:00:00
DEFAULT_MOD	NOMINAL	STC
Nms:	1	1
Pmax:	272 W	272.4 W
V _m :	35.90 V	35.79 V
I _m :	7.570 A	7.611 A
V _{oc} :	43.97 V	43.98 V
I _{sc} :	8.150 A	8.131 A
Irr:	1000 W/m ²	1000 W/m ²
T _c :	AUTO 25.0 °C	25.0 °C
Ptol:	+ 3.0% - 3.0%	0.1%
Pmax @ STC	OK*	Irr < 800W/m ²

D. FILE LIST

1. Press  (**FILE EXIT**) button to display the File List as below.
2. In the File List you can see: File names, File types, File dates/times.
3. There are three file types:
 - "Mod" : File of Solar panel parameters.
 - "REC" : File of I-V curve record.
 - "PWR" : File of Power record.
4. If there is a "*" symbol next to a "Mod" file, it means this file of solar panel parameters is the one currently used by the Analyzer.
5. Users can press  or  button to select a file. The chosen file will be highlighted. Press  or  button to display the files of previous page or next page.
6. Press **ENTER** button to open the file data. Open a "Mod" file means you select it as the file of solar panel parameters currently used by the Analyzer. Press "REC" button to display a File of I-V curve record. The "PWR" files can not be opened by the Analyzer, users have to read them from the Application Software.
7. Press  (**DELETE**) button to delete a chosen file.

※Note: When users enter the FILE LIST, the previous AUTO-SCAN testing results will be deleted.



File List	Type	Memory Free:	492KB
RECORD00001	* Mod	2012/05/01	11:00:00
DEMO0000001	REC	2012/05/01	12:00:00
RECORD00001	REC	2012/06/04	15:12:09
RECORD00002	REC	2012/06/04	15:13:09
RECORD00003	REC	2012/06/04	15:14:09
POWER_00004	PWR	2012/06/04	15:14:42
POWER_00005	PWR	2012/06/04	15:15:42
POWER_00006	PWR	2012/06/04	15:16:42
POWER_00007	PWR	2012/06/04	15:17:42
POWER_00008	PWR	2012/06/04	15:18:42
POWER_00009	PWR	2012/06/04	15:19:42
POWER_00010	PWR	2012/06/04	15:20:42
POWER_00011	PWR	2012/06/04	15:21:42



E. REF MODULE

After the parameter tests of Operating Condition (OPC), the Analyzer can convert them to I-V curve and parameter display of Standard Test Condition (STC). And then based on the parameters of solar panel to verify the solar panel is OK or NO OK. Users can open, modify, delete the parameters of solar panels. The default parameter file (DEFAULT_MOD) can not be modified or deleted.

1. Press  (**REF MODULE**) to enter the function of editing solar panel parameters.
2. The parameters of Solar panels are:
 Module : The name of solar panel which can be edited by SOFTWARE KEYBOARD.
 Nms : The series number of solar panels.
 Pmax : Max. solar system power.
 Voc : Voltage at open circuit.
 Isc : Current at short circuit.
 Vpm : Max. voltage at Pmax.
 Ipm : Max. current at Pmax.
 Area : Area of solar panel(s). (Based on this Area data and Irradiance, the Analyzer can calculate the conversion efficiency of solar panels.)
 Toll+ : Positive tolerance of solar panel **Pmax**.
 Toll- : Negative tolerance of solar panel **Pmax**.
 Alpha : Temperature coefficient of solar panel **Isc**.

Beta : Temperature coefficient of solar panel **Voc**.
 Gamma : Temperature coefficient of solar panel **Pmax**.
 K : Temperature coefficient of solar panel **Rs**.

3. Users can press  button or  button to select a parameter.

Press  button or  button to change the parameter values; or press these 2 buttons for 2 sec. to quickly change the setting values.

4. After editing the parameters, select **Save** and then press ENTER button to replace the original parameter file; or select **Save As** and then press ENTER button to save it as another new parameter file.
5. Press  (**REF MODULE**) button to exit REF MODULE function.

```

Module:  DEFAULT_MOD
Name:    1
Pmax:    272 W
Voc:     43.97 V
Isc:     8.150 A
Vpm:     35.90 V
Ipm:     7.570 A
Area:    1.944 m²
Toll+:   3.0%   Toll-:  3.0%
Alpha:   0.090%/°C
Beta:    -0.340%/°C
Gamma:   -0.370%/°C
K:       1.00 mΩ/°C
Save
Save As...
```



※Note: When users enter the REF MODULE function, the previous AUTO-SCAN testing results will be deleted.

Note: If users exit REF MODULE function before SAVING the parameter file, the changed parameters will be restored to the original defaults.





F. SOFTWARE KEYBOARD

Users can use SOFTWARE KEYBOARD to type in characters, numbers and symbols.

1. Move to the item where you want to change the characters (e.g. Module).

2. Press  button or  button to move the cursor to the place where you want to type in a character.

3. Press  (**SOFTWARE KEYBOARD**) button then the display will be as below.

4. In the SOFTWARE KEYBOARD display, press  or  or  or  button to select a character, then press  (**SOFTWARE KEYBOARD**) button again to confirm this change.

```

Module: NEW_MODULE
Nms: 1
Pmax: 500 W
Uoc: 100.0 U
Isc: 7.000 A
Uem: 85.00 U
Ipm: 5.880 A
Area: 2.500 m²
Toll+: 3.0% Toll-: 3.0%
Alpha: 0.090%/°C
Beta: -0.340%/°C
Gamma: -0.370%/°C
K: 1.00 mΩ/°C
  
```

!	"	#	\$	%	&	'	()	*
+	,	-	.	/	0	1	2	3	4
6	7	8	9	:	;	<	=	>	? @
A	B	C	D	E	F	G	H	I	J K
L	M	N	O	P	Q	R	S	T	U V
W	X	Y	Z	[\]	^	_	

Save
Save As...

G. ZERO Calibration

Calibration of voltage and current zero would improve the accuracy of the instrument before usage.

First connect "4-wire to 2-wire cable" with the Analyzer, then connect 2 testing clips (black & red) with "4-wire to 2-wire cable". Connect these 2 testing clips with each other and press  button. The LCD will display "ZERO CAL..." message. When this message disappears, the ZERO Calibration is completed.

Regular ZERO Calibration would maintain the accuracy of the instruments.

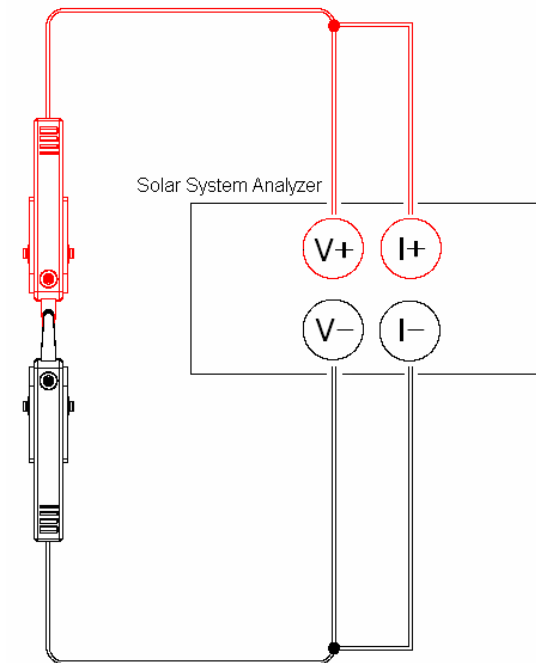

H. Data Logging

Users can perform Data Logging to record the I-V curves of solar system or (under POWER mode) record the DC/AC output power, Efficiency over a period of time (e.g. every 60 minutes).

```
CURRENT DATE&TIME: 2012/06/05 15:28:16
Sampling Time of Datalogging: 60min
Sens:47.35mV @1000W/m²  AUX      V1.00
Tc Offset: 0.0°C
Comment:
```

1. Set Sampling Time (e.g. 60 min.) in SETUP menu.
2. Exit SETUP function, press REC button then AUTO SCAN will be performed and the I-V curves of solar system will be recorded. In the above example, data is recorded once every 60 minutes. Press REC button again to stop Data Logging.
3. Under Efficiency display of Power mode, press REC button then (in the above example) the data is recorded once every 60 minutes. Press REC button again to stop Data Logging.



Note:

1. If the Sampling Time is set to 0 (minutes), then only 1 set of I-V curve/data or 1 set of power data is recorded.
2. Users can use the application software provided with the Analyzer to read the saved testing results. (Please refer to the Software Manual)

I. Clear Recorded (File) Data and Restore Defaults

Users can clear the recorded data saved in the Analyzer and restore the factory defaults.

The procedures are:

1. Keep pressing **REC** button and turn on the Analyzer at the same time.
2. After turning on the Analyzer, users will be asked if they really want to Restore Factory Settings & MEMORY FORMAT. If users choose YES, then all the data recorded in the Analyzer (memory) will be completely deleted. And the factory default settings will be restored.

Note:



1. After performing this CLEAR function, all the recorded data in Analyzer (memory) will be deleted completely and can not be restored. If it is necessary to keep the testing data, please use the Application Software to download/save them before deleting them from the Analyzer. (refer to the Software Manual)



2. After the factory defaults are restored, the parameters (like Sens, Tc Offset, ...) in SETUP will be restored to the defaults set at factory. Hence, users will have to set the parameters in SETUP again.



J. SETUP Parameters

1. Press  (**SETUP**) button to enter the Parameter Setting.

2. Press  or  buttons to select the setting item.

Press  or  buttons to change the setting values. Or press these two buttons for 2 sec. to promptly change setting values.

3. After setting up parameters, press  (**SETUP**) button to exit SETUP menu.

```
CURRENT DATE&TIME: 2012/06/06 11:02:53
Sampling Time of Datalogging: 60min
Sens:47.35mV @1000W/m²  AUX      U1.00
Tc Offset:  0.0°C
Comment:
USERS CAN EDIT COMMENT OR INFORMATION
HERE.
INFORMATION 1. 2. 3. ...
```

- (1) **CURRENT DATE&TIME** : the Date and Time of the Analyzer will be set up (except the Second can not be set).
- (2) **Sampling Time of Datalogging** : can be set up from 0 to 99 minutes.

- (3) **Sens** : in order to measure the correct irradiance, here users must set up the Sens values which were printed on the auxiliary thermometers (back side) attached to the Irradiance meters. After the factory defaults are restored, the Sens values will be restored to the ones set up at the factory. If the Irradiance meter is recalibrated, the Sens value after calibration must be set up here.
- (4) **Tc Offset** : in order to measure the correct temperature, here users must set up the Tc Offset values which were printed on the auxiliary thermometers (back side) attached to the Irradiance meters. After the factory defaults are restored, the Tc Offset values will be restored to the ones set up at the factory.
- (5) **Comment** : Users can use the SOFTWARE KEYBOARD to write down their comments here. Max. 128 characters can be typed in. When data logging (REC) I-V curves of solar system, the comment will be recorded as well.
- (6) **AUX** in the SETUP menu means the auxiliary thermometer (attached to Irradiance meter) is selected for Cell Temperature. **V1.00** means the firmware version of the Analyzer.

K. THERMOMETER Setup

1. Keep pressing  (**REF MODULE**) button (do not release it) and turn on the power of Analyzer.
2. After the power is on, users will be asked to select AUTO or AUX for "Cell Temperature". Choosing AUTO means the Analyzer will automatically detect the temperature of solar panel. Choosing AUX means the Analyzer will detect the temperature of solar panel through the auxiliary thermometer of Irradiance meter.



Note:

In order to get more accurate temperature of solar panel, users are suggested to select AUTO. When users select AUTO, they have to make sure the **Voc** parameter of REF MODULE is correct.

L. POWER Mode

Solar System with Panels and Inverter

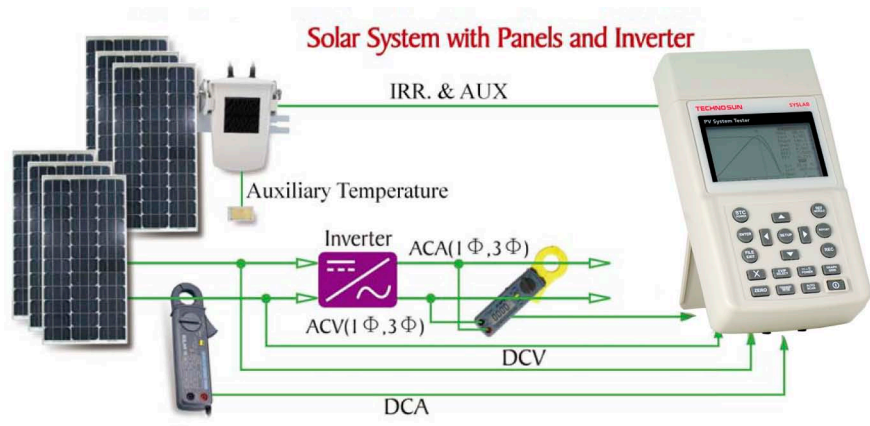

The connection of Solar 21 (AC Power Clamp), Analyzer, Irradiance meter and Solar 15 (DC Current Probe) are as below:



The POWER mode is used to continuously measure/monitor/record the DC power output of solar system and the AC power output of Inverter (1 phase or balanced 3 phases); calculate the efficiency of DC to AC power conversion, the efficiency of the max. output power, DC/AC output power, and Watt/hour, etc.

Please connect all the cables according to the drawing of "Solar System with Panels and Inverter". Solar 15 (DC Current Probe) turned to 12A range; Solar 21 (AC Power Clamp) turned to W-mA or W-A range; the sliding switch on the side turned to a proper frequency.

Press the 3-Phase button of **Solar 21** (AC Power Clam) to switch to 1P2W or 3P3W.

1. Press  button to turn on the Analyzer.

2. Press  (**STC POWER**) button to enter the Efficiency display of POWER mode as below.

RECORD00001	DC POWER	AC POWER 1P2W
Voc: 82.15 U	335.2 W	309.3 W
Isc: 5.880 A	70.40 U	112.8 U
Pmax: 347.3 W	4.761 A	2.750 A
Vpm: 70.43 U		0.997
Ipm: 4.931 A	EFF(Pmax)	EFF(DC-AC)
Irr: 1050 W/m ²	96.5%	92.3 %
Tc: 51.2 °C	EFF: 97.2%	EFF 93.1 %
Alpha 0.090%/°C	P̄: 337.2 W	P̄: 313.2 W
Beta: -0.340%/°C		PF: 0.997
Gamma -0.370%/°C	ET: 00:05:00	Battery: 100%
Irh: 87.5 Wh/m ²	Ph: 28.1 Wh	Ph: 26.1 Wh
SPmh: 28.9 Wh		

On the top left of the display, "RECORD00001" means the current output calculation of solar panels are based on: I-V curve record file "RECORD00001" and the measured irradiance/temperature. Every sec. the calculation and display is updated once. Hence users must perform AUTO SCAN first, press REC button to record a "REC" file, select this "REC" file in FILE LIST, then press ENTER button to finish the nomination.

Parameters from left to right on the display are described on below:

Output of solar panels:

- Voc : Voltage at open circuit
- Isc : Current at short circuit
- Pmax : Max. solar system power
- Vpm : Max. voltage at Pmax

- Ipm : Max. current at Pmax
- Irr : The measured Irradiance
- Tc : The measured Temperature
- Alpha : Temperature coefficient of solar panel **Isc**.
- Beta : Temperature coefficient of solar panel **Voc**.
- Gamma : Temperature coefficient of solar panel **Pmax**.
- Irh : Watt/ hour of Irradiance
- SPmh : Watt/ hour at Pmax

DC Input of Inverter:

- P : Power
- V : Voltage
- I : Current
- EFF(Pmax) : Efficiency, (DC Power / Pmax)x100
- EFF̄ : Average Efficiency, (Ph(DC)/SPmh)x100
- P̄ : Average Power
- ET : Duration (hour: min.: sec.). Users can press ZERO button to reset this value.
- Ph : Watt/ hour

AC Output of Inverter:



- P : Power
- V : Voltage
- I : Current
- PF : Power Factor
- EFF(DC-AC) : Efficiency, (P(AC)/P(DC))x100
- EFF̄ : Average Efficiency, (Ph(AC)/Ph(DC))x100
- P̄ : Average Power

PF : Average Power Factor
 Ph : Watt/ hour

3. Press  button to switch the display to DC power curve as below.

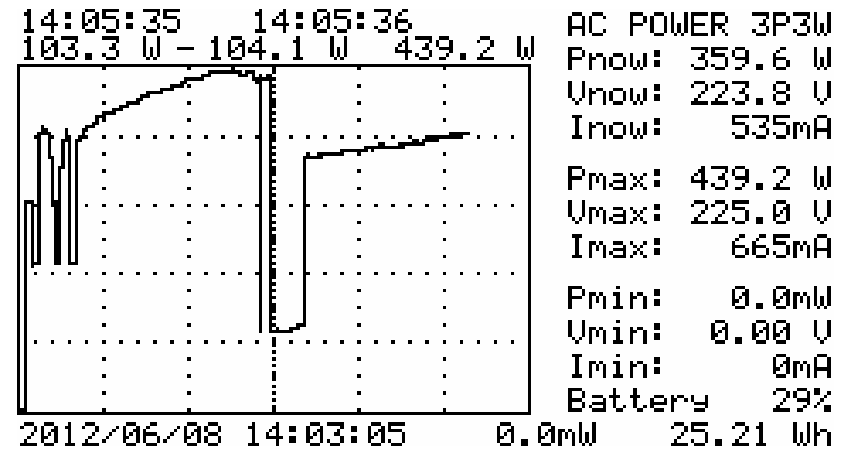
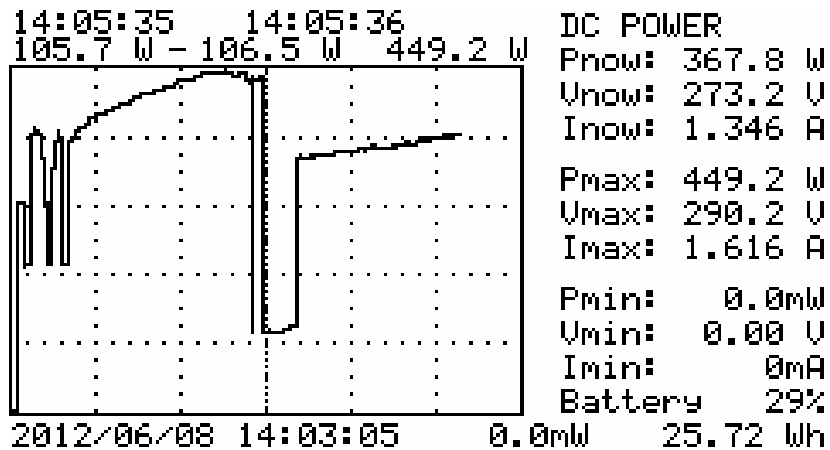
Press  button again to switch the display to AC power curve as below.



Users can press  (I/V/P SELECT) button to switch the display to Current/Voltage/Power curves. On the left bottom it shows the starting date/time of the curve. Users can press ZERO button to Reset (i.e. redraw) the curve. Press  or  button to move the cursor. On the top left it shows the Time Interval of the cursor position, and the min./max. values of the Time Interval. On the right bottom it shows Watt/ hour.

Note:



1. Under POWER mode if the display shows “Clamp X”, it means the Analyzer can not detect Solar 15 or Solar 21, please check the connection or replace batteries.
2. Solar 15 ”can be turned to 12A range only”, Solar 21 ”can be turned to W-mA or W-A range only”, or the Analyzer can not measure correctly.

V. Application Notes

A. Quality Control at Production Line, Warehouse, or Site of Installation.

Manufacturers of solar panels can test the characteristics for quality control purpose at the production line. Due to the portability advantage of the unit, quality inspectors can randomly pick samples of solar panels and test them at the warehouse to assure quality before shipment.

Installation engineers can randomly test samples of solar panels at site to verify the quality of solar panels used at site of installation.

B. Identify Requirements of Solar Power System

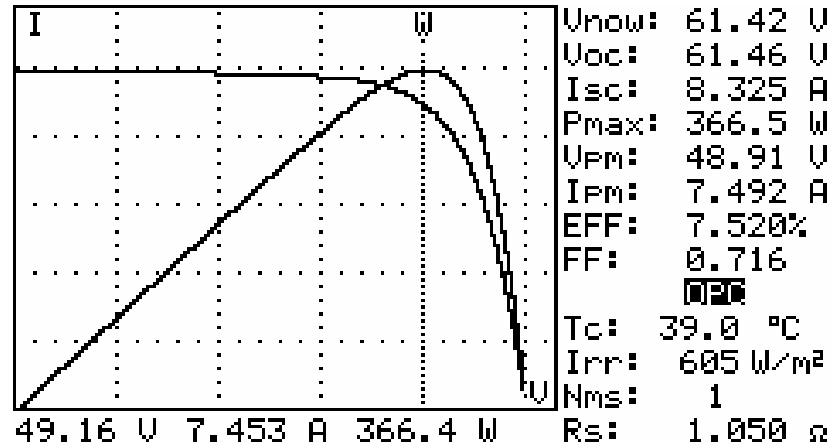

The unit can measure actual max. power (Pmax), voltage (Vpm) and current (Ipm) at max. power. Instead of the rated max. power, system designers need to be aware of the actual solar power from solar panels under actual operating conditions. So designers can actually know how many pieces of solar panels are required to generate specific power.

The voltage and current under actual operating conditions (in the morning, at noon, and in the afternoon) are required for system designers to design the optimal charging system, so most of the solar power can be absorbed and stored in the battery.

Users can test the characteristics of solar panels at different time of each day and store the data. Then the designers can know if the solar system can generate appropriate power at any time.

C. Maintenance of Solar Panels

Normal I-V Curve

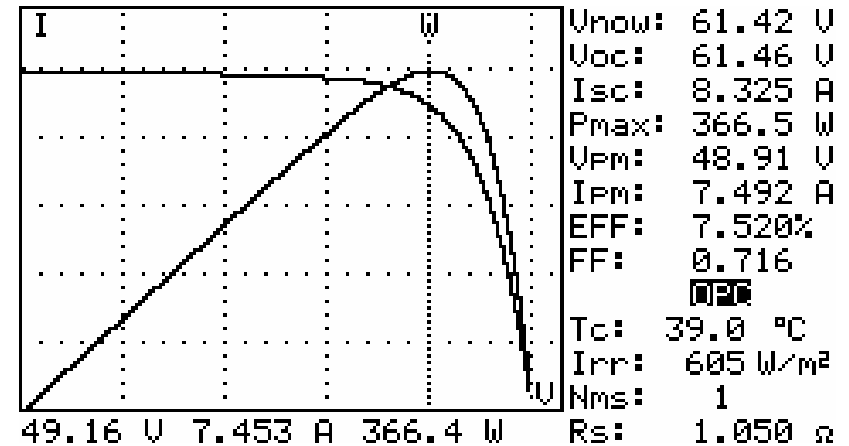

Abnormal I-V Curve

(Cells at the corner of solar panel are defected)

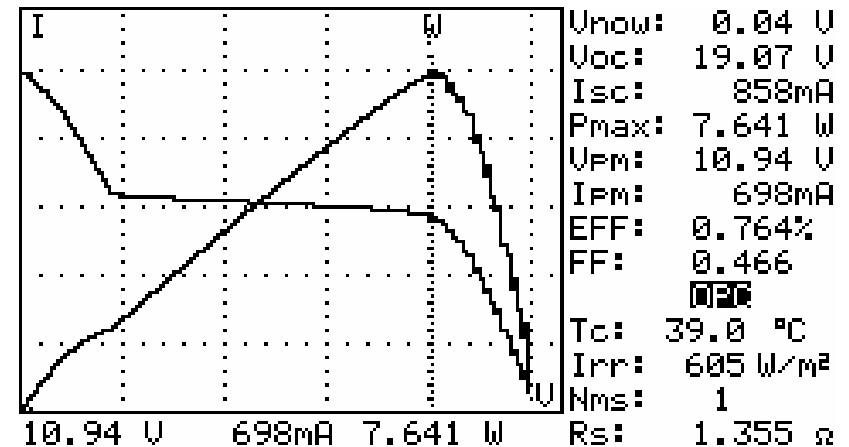

Abnormal I-V Curve

(Defected cells scattered over the solar panel)

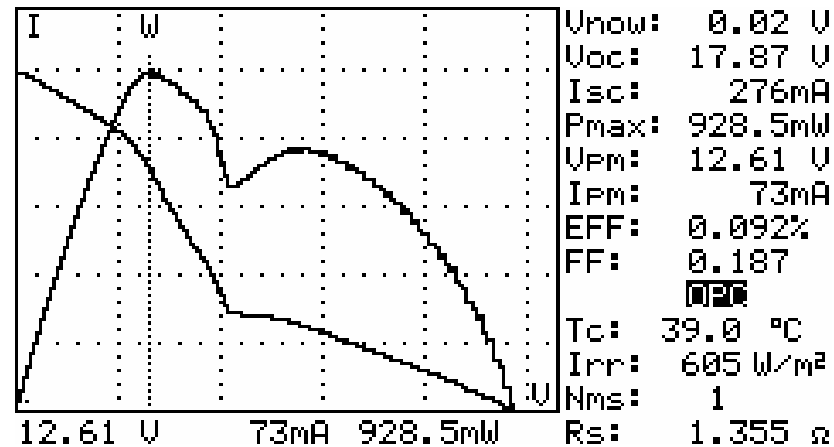

Maintenance engineers can store the characteristics data of solar panels in the beginning. And compare the characteristics data in weekly, monthly or yearly maintenances. If the characteristics of any solar panels are different from the previous data, maintenance engineers can further identify the problems of solar panels.

For example, if any cells of solar panels are damaged, the I-V curve would be very different from a typical curve. If the solar panels are covers by a lot of dust, the I-V curve or the max. power would be much lower than previously stored data. Once defected panels are found, maintenance engineers can replace them with new panels.

D. Verify the Best Installation Angles of Solar Panels

Engineers can collect data of the installation angles at different dates and time by using the unit at site of installation. The data can be used as a reference to design the automated angle adjustment system. Or the data can be used to select an optimal angle for a fixed angle installation.

VI. Specifications

A. Electrical Specifications

A1. Solar System Analyzer

(23°C±5°C, Irradiance ≥ 800 W/m², Four-wire measurement, the Max. power limit is 12000W)

DC Voltage Measurement

Range	Resolution	Accuracy
1 ~ 1000 V	0.01 V / 0.1 V / 1 V	± 1 % ± (1 % of Voc ± 0.1 V)

Voc: open circuit voltage of solar cell or module.

If users use testing clips to measure voltage only, they must make V+ clip connect with I+ clip; V- clip connect with I- clip. Thus, 4-wire measurement is converted to 2-wire measurement.

DC Current Measurement

Range	Resolution	Accuracy
0.1 ~ 12 A	1 mA / 10mA	± 1 % ± (1 % of Isc ± 9 mA)

Isc: short circuit current of solar cell or module.

Circuit resistance is compensated in the AUTO SCAN.

Isc is the current of solar panel's power cable measured at zero circuit resistance.

DC Current Simulation

Range	Resolution	Accuracy
0.1 ~ 12 A	1 mA / 10 mA	± 1 % ± 9 mA

If current is greater than 12A, testing can not be performed.

Maximum power limit is 12000W. If the power exceeds 12000W, then the scanning will be stopped.

The min. current for Auto Scan is 100mA.

Irradiance Measurement

Range	Resolution	Accuracy
50 ~ 2000 W/m ²	1 W/m ²	± 3 % ± 20 dgts

Temperature Measurement

Range	Resolution	Accuracy
-20 ~ 85 °C	0.1 °C	± 1 % ± 1 °C

A2. DC Current Probe (Solar 15) (23°C±5°C)

Range	Resolution	Accuracy
DC 12A	1 mA / 10 mA	±2.0%±30mA

A3. AC Power Clamp (Solar 21) (23°C±5°C)

AC Watt (50 or 60 Hz, PF 0.6 to 1. CT = 1, Voltage is greater than AC 4V, Current is greater than AC 1mA for mA range, and Current is greater than AC 0.04A for A range. Spec. applies to continuous waveforms.)

Range (0 to 30A)	Resolution	Accuracy of Readings ^{1,2}
0.050 – 9.999 W	0.001W	±2% ± 0.025W
10.00 – 99.99 W	0.01W	±2% ± 0.25W
100.0 – 999.9 W	0.1W	±2% ± 2.5W
1.000 – 9.999 KW	0.001 KW	±2% ± 0.025KW
10.00 – 99.99 KW	0.01 KW	±2% ± 0.25KW
100.0 – 999.9 KW	0.1 KW	±2% ± 2.5KW
1000 – 9999 KW	1 KW	±2% ± 25KW

¹ For CT ≠1, the accuracy in percentage is the same (±2%). But the additional wattage should be multiplied by the CT ratio.

For example, ±0.025W becomes ±0.025W * CT ratio

² If Auto Hz is selected, the AC voltage must be greater than 50V, and add 2° phase angle error to the accuracy.

Range (30 ~ 50A)	Resolution	Accuracy ^{3,4}
0.050 – 9.999 W	0.001W	±2% of VA ± 5dgts
10.00 – 99.99 W	0.01W	±2% of VA ± 5dgts
100.0 – 999.9 W	0.1W	±2% of VA ± 5dgts
1.000 – 9.999 KW	0.001 KW	±2% of VA ± 5dgts
10.00 – 99.99 KW	0.01 KW	±2% of VA± 5dgts
100.0 – 999.9 KW	0.1 KW	±2%of VA ± 5dgts
1000 – 9999 KW	1 KW	±2% of VA ± 5dgts

³ For CT ≠1, the accuracy in percentage is the same (±2%). But the additional digits should be multiplied by the CT ratio.

For example, ±5 digits becomes ±5 digits * CT ratio

⁴ If Auto Hz is selected, the AC voltage must be greater than 50V.

Range of CT Ratio: 1 to 250

H.P. (Horse Power): 1 H.P. = 746 W

AC Apparent Power (VA, from 0.000VA to 9999 KVA)

$$VA = V \text{ r.m.s.} \times A \text{ r.m.s}$$

AC Reactive Power (VAR, from 0.000 VAR to 9999 KVAR)

$$VAR = \sqrt{(VA^2 - W^2)}$$

AC Active Energy (mWH, WH, or KWH, from 0 mWH to 999,999 KWH)

$$WH = W * \text{Time (in hours)}$$

Power Factor

(PF, ACV > 4V, AC mA > 1mA, AC A > 0.04A, Watt > 50 digits)

Range	Resolution	Accuracy
0.000 – 1.000	0.001	±0.04

	Testing clips (1 black & 1 red)
--	---------------------------------

B. General Specifications

B1. Solar System Analyzer

Battery Type:	Rechargeable Lithium Battery (3400mAh)
Battery Life:	400 times of linear scan (1000V ~ 1V, 0.1A ~ 12A), 8 hours for standby mode.
Memory Size:	512K Bytes 3980 Mod files 320 REC files 3980 PWR files
AC Adaptor:	AC 100 ~ 240V input DC 15V / 1~3A output
Dimension:	257(L) x 155(W) x 57(H) mm
Weight:	1525g / 53.7 oz (Batteries included)
Operation Environment:	5°C ~ 50°C, 85% RH
Temperature Coefficient:	0.1% of full scale / °C (< 18°C or > 28°C)
Storage Environment:	-20°C ~ 60°C, 75% RH
Accessories:	Irradiance meter, User manual, AC adaptor, Optical USB cable, Rechargeable lithium battery, Software CD, Software manual, Carrying bag, Thermal conductive gel, Testing clips (1 black & 1 red), 4-wire to 2-wire connecting cable, 4-wire testing cable
Option:	Solar 15: DC current probe Solar 21: AC power clamp

B2. DC Current Probe (Solar 15)

(Indoor Use)

Conductor Size:	23mm max. (approx.)
Battery Type:	two 1.5V SUM-3 AA
Range Selection:	Manual
Power Consumption:	10mA (approx.)
Low Battery Indication:	Red LED
Operation Temperature:	-10°C to 50°C
Operation Humidity:	< 85% RH
Storage Temperature:	-20°C 到 60°C
Storage Humidity:	< 75% RH
Altitude:	up to 2000M
Dimension:	183mm(L) x 61.3mm(W) x 35.6mm (H) 7.2" (L) x 2.5" (W) x 1.4" (H)
Weight:	190g (battery included)
Accessory:	Carrying bag x 1 Manual x 1 1.5V AA battery x 2

B3. AC Power Clamp (Solar 21)

(Indoor Use)

Conductor Size:	30mm (approx.)
Battery Type:	two 1.5V SUM-3 AA
Display:	4+2+2 digits LCD
Range Selection:	Auto
Overload Indication:	OL
Power Consumption:	10mA (approx.)
Lower Battery Indication:	
Display Update Time:	2 times / sec.
No. of Samples per period:	512 (V or A) 256 (W)
Temperature Coefficient (<math>< 18^{\circ}\text{C}</math> or $> 28^{\circ}\text{C}$):	0.15 x (Specified Accuracy) / $^{\circ}\text{C}$
Operation Temperature:	-10 $^{\circ}\text{C}$ to 50 $^{\circ}\text{C}$
Operation Humidity:	< 85% RH
Altitude:	up to 2000M
Storage Temperature:	-20 $^{\circ}\text{C}$ to 60 $^{\circ}\text{C}$
Storage Humidity:	< 75% RH
Dimension:	210mm(L) x 62mm(W) x 35.6mm(H) 8.3" (L) x 2.5" (W) x 1.4" (H)
Weight:	200g (battery included)
Accessory:	Test leads, Carrying bag, Manual, 1.5V AA battery x 2
Option:	Alligator clips

VII. Battery Replacement (Recharging)

If the lithium battery can not be charged, users should always purchase a new lithium battery from the distributor or importer. The charging circuit built-in is designed only for the lithium battery included.

The lithium battery is always sold with the plastic battery cover. Do not purchase a lithium battery from a source which is not approved by the manufacturer.

Non-approved lithium battery could cause damage to the instrument or hazard to the users.



Steps of Battery Replacement:

1. Unscrew and remove the battery with cover.
2. Put in a new recharging battery with cover.
3. Screw the battery cover.

Please follow the below steps to charge the lithium battery:

1. Connect the AC Adaptor with the Analyzer.
2. The charging can be done without turning on the Analyzer.
3. The recharging takes 10 hours. After recharging, remove the AC Adaptor.
4. Turn on the Analyzer, and the LCD displays "Battery: 100%".

VIII. Fuse Replacement

When the voltage can not be measured ($V_{now} = 0V$) after properly connecting the Analyzer and solar panel, please check the fuse. If the fuse is damaged (burned), please replace a new fuse by following the procedures:

1. Turn off the Analyzer and remove all the connecting wires and power sources.
2. Unscrew the (2pcs.) screws of the top panel. Remove the top panel.
3. Remove the damaged (burned) fuse.
4. Put in a new fuse of the same specifications (5A / 250V).
5. Restore the top panel and screw the (2pcs.) screws of the top panel.

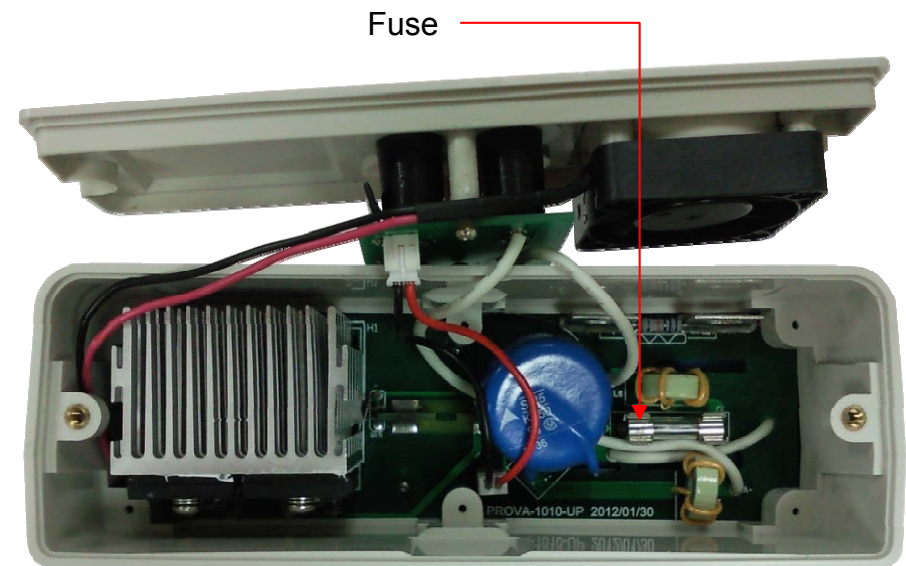

IX. Maintenance & Cleaning

1. Servicing not covered in this manual should only be performed by qualified personnel. Repairs should only be performed by qualified personnel.
2. Periodically wipe the case and cable with a damp cloth and detergent; do not use abrasives or solvents.
3. Please remove the batteries if users won't use the solar analyzer and optional clamps for a long time.