



PS 230

DUAL CHANNEL SPEAKER STATION



USER MANUAL

Issue 2011 © ASL Intercom BV

DESIGNED AND MANUFACTURED BY:

ASL Intercom B.V.
Zonnebaan 42
3542 EG Utrecht
The Netherlands
Phone: +31 (0)30 2411901
Fax: +31 (0)30 2667373
E-mail: info@asl-inter.com
Web: www.asl-inter.com

CONTENT OF THIS USER MANUAL

1.0	GENERAL DESCRIPTION	3
2.0	UNPACKING	3
3.0	INSTALLATION	3
4.0	FRONTPANEL CONTROLS & CONNECTORS	4
6.0	INTERNAL CONTROLS	6
7.0	WARRANTY	6
8.0	TECHNICAL SPECIFICATIONS	6
9.0	PARTY LINE, TECHNICAL CONCEPT	7
10.0	CABLING	7
11.0	PS 230 BLOCK DIAGRAM	8
12.0	SYSTEM CONFIGURATION	8
13.0	EARTHING CONCEPT	9

1.0 GENERAL DESCRIPTION

The PS 230 is a dual channel speaker station designed for use in both portable and fixed ASL intercom systems. It incorporates a loudspeaker and a gooseneck microphone and provides full duplex communications.

The PS 230 RM model has a small built-in electret microphone.

Each channel has Volume (listen level) Control, a TALK and CALL button with LED indicators and a 2-stage side tone trimmer. Furthermore there are trimmers for speaker attenuation and buzzer volume.

The unit is equipped with a limiter for the gooseneck microphone, allowing the user to speak close into the microphone without giving rise to overload and distortion.

Loudspeaker dimming is automatic when the gooseneck microphone is active. Private conversation may be carried out via the headset connector with a headset or telephone handset. When a headset is connected, both the gooseneck microphone and speaker are disabled automatically.

The XLR-4 headset connector can be replaced (by ASL) by a XLR-5 connector for binaural use of the headset.

Special attention has been paid to the intelligibility of speech. By applying low noise/high speed op-amps, a speech presence filter and a specially developed high power bridged headphone amplifier, communication is very comfortable even in environments with high back-ground noise level. There is a separate amplifier for the loudspeaker.

The unique ASL CALL system provides both a flashing red LED and a very characteristic sound signal (the buzzer). Smooth operation is guaranteed with the CALL button. Only a slight touch makes the red LED flash, whilst holding the button for two seconds activates the CALL sound signal. The volume of this signal (the buzzer) can be adjusted at the front panel.

Fully electronic switching increases reliability and allows for :

- 'soft' microphone ON switching, latching or momentary
- remote Mic Mute facility
- automatic speaker attenuation (adjustable), when the microphone is activated

2.0 UNPACKING

The shipping carton contains the parts below:

- * The PS 230
- * User manual

If any are missing, contact your dealer.

ASL has taken great care to ensure this product reaches you in flawless condition. After unpacking the unit please inspect for any

physical damage to the unit, and retain the shipping carton and relevant packing materials for use should the unit need returning.

If any damage has occurred, please notify your dealer immediately so that a written claim can be initiated. Please also refer to the warranty section of this manual.

3.0 INSTALLATION

Connecting the PS 230 to an intercom system is straightforward. Connect the intercom lines (the 'party lines') to the LINE connectors on the side panel of the PS 230.

There are no separate power connections or batteries to install, as the necessary DC voltages are derived from a master station or a separate power supply, via the intercom connection cables.

Use professional flexible microphone cable with 2 wires and 1 shield only

The PS 230 is fully protected against wiring mistakes (reverse power) or short circuit in the interconnecting cables.

A special kit is available for mounting the PS 230 in a 19" rack, taking 2U of rack space.

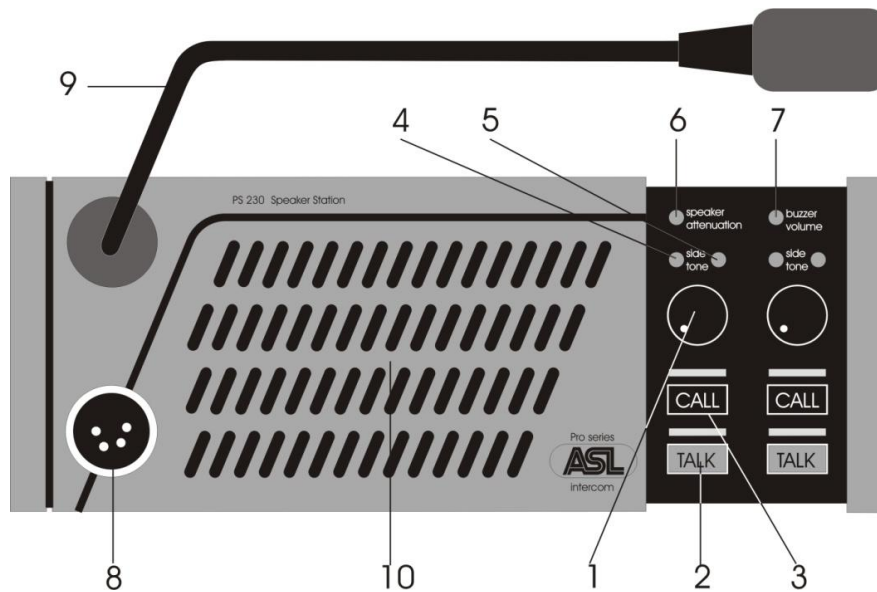

1 VOLUME control knobs

These knobs, one for each channel, adjust the listen level for the headset and the loudspeaker.

2 TALK buttons

These push buttons, one for each channel, activate the gooseneck or headset microphone. The large green LEDs indicate if the microphone is switched on.

Momentary switching:

If a TALK button is pushed and held, the microphone signal is sent to the corresponding intercom channel until the button is released.

Latched switching:

If a TALK button is pushed quickly it is electronically latched and the microphone signal is sent to the corresponding intercom channel. If pushed again, the TALK button switches off.

Mic Mute when latched on:

After on the intercom channel a so-called MIC Mute signal has been received from a PRO Series master station or separate power supply, the connection between microphone and intercom channel is interrupted. By pushing the TALK button the connection is restored again.

3 CALL buttons

These push buttons (one for each channel) activate the call system.

By a momentary push a visual call signal is sent to all stations connected to the corresponding intercom channel and the call LEDs start flashing. By holding a CALL button pushed for 2 seconds the call buzzer is activated, provided there is no 'buzzer mute' on one or both intercom channels. After the CALL button is released the LEDs continue to flash for a further 2 seconds.

4 SIDE TONE LEVEL trimmers

These trimmers, one for each channel, are for minimizing the speaker feeding back into the gooseneck microphone (unit feedback). They also determine the level of your own voice as you hear it in the speaker or headset.

5 SIDE TONE HI trimmers

These trimmers, one for each channel, have the same function as trimmer #5, but solely for the high frequencies.

Adjustment procedure for both side tone trimmers, for each channel separately:

- set trimmer in start position: fully clockwise
- switch off the microphones of all connected (speaker) stations
- make sure there is no automatic speaker attenuation (turn trimmer #6 fully clockwise)
- push the TALK button of the corresponding channel
- slowly turn up the listen volume
- speak into the gooseneck microphone

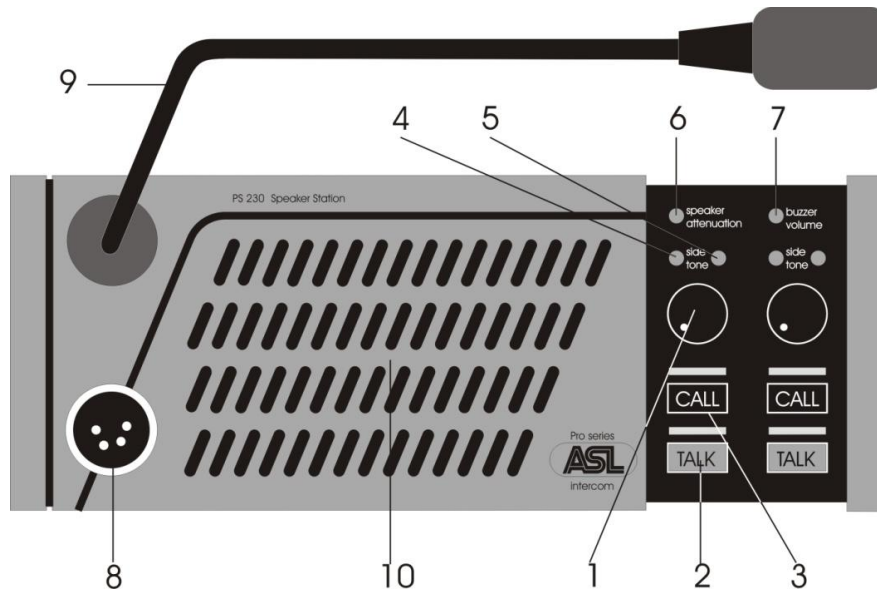

- adjust the speaker listen level of the corresponding channel to a minimum by turning the side tone trimmers counter clockwise (first trimmer #4 and then trimmer #5; repeat this a few times)
- Connect a headset to the PS 230 (the speaker and gooseneck mic are now automatically disabled) and speak into the headset microphone
- Check whether the level of your voice in the headset can(s) is sufficient. If not, push up the listen level of the corresponding channel a bit by turning side tone trimmer #4 clockwise.

- adjust the desired degree of speaker attenuation (turning the trimmer counter-clockwise increases the attenuation)

7 BUZZER VOLUME trimmer

This trimmer adjusts the volume of the internal buzzer. The buzzer is activated if a CALL button of the PS 230 is pushed (or a CALL button of any other station on a channel to which the PS 230 is connected) longer than 2 seconds, provided there is no 'buzzer mute' on one of the channels.

8 HEADSET connector

To this XLR-4 connector a headset may be connected. The headset can must have an impedance of 200 ohms minimum. When there 2 cans in parallel each can must have an impedance of 400 ohms minimum. The headset microphone may be of the dynamic or electret type.

XLR-4 pin assignments :

- Pin 1. Shield mic. (GND)
- Pin 2. mic. +
- Pin 3. phones +
- Pin 4. phones

When connecting a headset, the speaker and gooseneck microphone are disabled automatically.

9 GOOSENECK MICROPHONE

The PS 230 is equipped with an electret noise canceling gooseneck microphone. A limiter prevents the microphone preamplifier from clipping when speaking close into the microphone

10 LOUDSPEAKER

A high quality loudspeaker driven by a 2.9 Watt amplifier.

The trimmers operating area is between fully clockwise and minimum level. Adjusting the side tone does not affect the level of your voice as it is heard by other stations.

6 SPEAKER ATTENUATOR trimmer

This trimmer adjusts the extent to which the speaker is automatically dimmed when the gooseneck microphone is switched on. It prevents unit feedback if side tone rejection is not sufficient. It also minimizes system feedback or a 'hollow' sound when the gooseneck microphones of other speaker stations on the intercom channel are switched as well.

Adjustment procedure :

- make sure there is no headset connected
- feed an audio signal into one of the intercom channels (via an AUX input on a master station or a separate power supply)
- turn up the listen volume
- activate the gooseneck microphone

5.0 SIDE PANEL CONNECTORS

11 LINE connector channel A

12 LINE connector channel B

These connectors are for connecting the PS 230 to the party lines of an intercom system.

XLR-3 pin assignments :

1. 0 V /ground shield
2. +30V power wire
3. audio wire

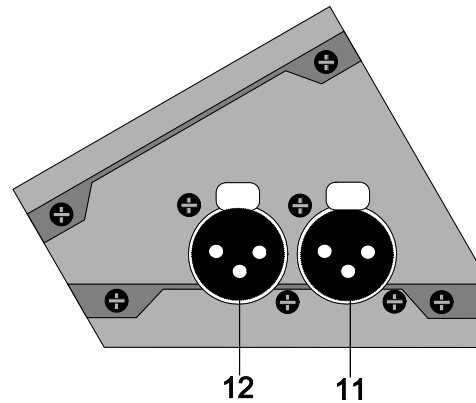

6.0 INTERNAL CONTROLS

Inside the unit there are two trimmers to adjust the mic gain of the gooseneck microphone and the headset microphone separately. The trimmers are located on the PC board.

The trimmers can be reached as follows :

- remove the screws of the bottom plate

- slide the plate to one side and take it out
- take away the plastic isolation plate

The two trimmers are labeled :
'GOOSE' for the gooseneck microphone
'HEADS' for the headset microphone

7.0 WARRANTY

This unit is warranted by ASL Intercom to the original end-user purchaser against defects in workmanship and materials in its manufacture for a period of one year from date of shipment to the end-user. Faults arising from misuse, unauthorized modifications or accidents are not

covered by this warranty. If the unit is faulty it should be sent in it's original packing, to the supplier or your local ASL dealer, with shipping prepaid. A note must be included stating the faults found and a copy of the original suppliers invoice.

8.0 TECHNICAL SPECIFICATIONS

System Specifications

Dynamic range: 80 dB (1 kHz, THD < 1%)
Call signal: (send): +2.8 mA
Call signal threshold (receive): +2.4V DC
Supply voltage: +30V DC (12V to 32V)
Power interrupt time (Mic Mute): 0.1 sec
Line Impedance: 350 Ω (1 kHz), 2.2 kΩ (DC)
Audio level: nom. -18 dBu, max. +4 dBu

Microphone Pre-amps

Headset mic impedance: 200 Ω
Gain: 40 – 60 dB (adjustable internally, separately for the headset mic and the gooseneck mic)
Presence filter: +6 dB @ 5 kHz
Frequency response: 200 Hz – 15 kHz (-3dB)
Power to electret mic: +9V DC
Limiter range (gooseneck mic): 30 dB

Headphone Driver Amp

Max. output level: 14 V rms (@ 200 Ω)
Max. output power: 1 W rms @ 400 Ω

Speaker Driver Amp

Speaker impedance: 25 Ω
Max. output power: 2.9 W rms

Side Tone

Rejection: 0 - 30 dB adjustable

Buzzer

Max. SPL: 85 dBA

PS 230 Power Consumption

Current (at 30V DC):
- 35 mA quiescent
- 70 mA signaling
- 190 mA at max. output + signaling

PS 2130 Dimensions & Weight

Width 230 mm / Height 88 mm
Depth 42/48 mm sloping / Weight 1.3 Kg

*0 dBu = 775 mV into open circuit
ASL reserves the right to alter specifications
without prior notice.*

9.0 PARTY LINE, TECHNICAL CONCEPT

User stations in an ASL intercom system are connected via one or several 'party lines'. A party line offers two way ('full duplex') communication and consist of standard microphone (multi-pair) cable. One wire is used as an audio line, one as a power line and the screen of the cable functions as earth/return.

Current drive is used for signal transfer. Each station utilizes a current amplifier to amplify the microphone signal and place it on the common audio line where, due to the constant line impedance, a signal voltage is developed which can be further amplified and sent to headphones or loudspeakers.

This principle has three advantages:

1. the use of a single audio line allows several stations to talk and listen simultaneously
2. due to the high bridging impedance offered by each station, the number of stations on the party line has no influence on the level of the communications signal
3. power and audio to the intercom stations use the same cable.

The Call signal is also sent as a current on the audio line. It develops a DC potential over the line impedance which is sensed by each station and interpreted as a Call signal.

10.0 CABLING

The intercom lines (the 'party lines') are of the shielded two-conductor microphone cable type. The intercom line connectors are of the XLR-3 type. Audio and Call signals are on pin 3, DC power is on pin 2 and pin 1 is connected to the shield of the cable which functions as the common return for audio and power.

The audio signal is transferred in an unbalanced way (see Party Line, Technical Concept). To avoid earth loops (hum), the possible effect of electromagnetic fields and to minimize power loss, certain rules have to be obeyed when installing the cabling of an ASL intercom system.

Use high quality cable

Use high quality microphone cable (shielded two conductor cable, minimum 2x 0.30 mm²).

In case multi-pair cable is used, each pair should consist of two conductors (minimum 2x 0.15 mm²) with separate shield and an overall shield.

Use flexible cable

Use flexible single and multi-pair microphone cable instead of cable with solid cores, especially when the cable is subjected to bending during operation or installation.

Cable screens to XLR pin 1

The screen of each separate microphone cable and/or the screen of each single pair in a multi-pair cable, should be connected to pin 1 of each XLR-3 connector. Do not connect this cable screen to the metal housing of ASL units or XLR-3 wall boxes. See section 'Earthing Concept'.

Connect cable trunks, connection boxes and overall multi-pair cable screens to clean earth

Metal cable trunks, metal wall boxes and overall multi-pair cable screens should be interconnected and, at the 'central earth point' in the intercom network only, be connected to a clean earth or a safety earth. See section 'Earthing Concept'.

Keep metal connection boxes and cable trunks or pipes isolated from other metal parts

Metal trunks or pipes for intercom cables and metal connector boxes should be mounted in such a way that they are isolated from any other metal housing or construction part.

In case of more complex installations, don't hesitate to contact us. Please send a block diagram of the planned network with a list of all user stations and their positions, and we are happy to advise you on cabling lay out.

Keep cables parallel as much as possible

When two (multi channel) units in a network are connected by more than one cable, make sure that these cables are parallel to each other over the whole distance between those units. When using multi-pair cable, parallelism is ensured in the best possible way.

Avoid closed loops

Always avoid that cables are making a loop. So-called 'ring intercom' should not physically be cabled as a ring.

Keep cables away from electromagnetic sources

Keep intercom cables away from high energy cables, e.g. 115/230/400V mains power or dimmer controlled feeds for spotlights. Intercom cables should cross high energy cables at an angle of 90° only. Intercom cables should never be in the same trunks as energy cables.

Place power supply in a central position

In case of a system powered by a separate power supply: In order to diminish power losses, place the power supply as close as possible to where most power consumption occurs, in other words most user stations are placed.

ASL powered units to a 'clean' mains outlet

Master stations or power supplies should be connected to the mains outlet with a clean earth. Other (audio) equipment may be connected to this outlet, but avoid using an outlet which also powers dimmer controlled lighting systems.

11.0 PS 230 BLOCK DIAGRAM

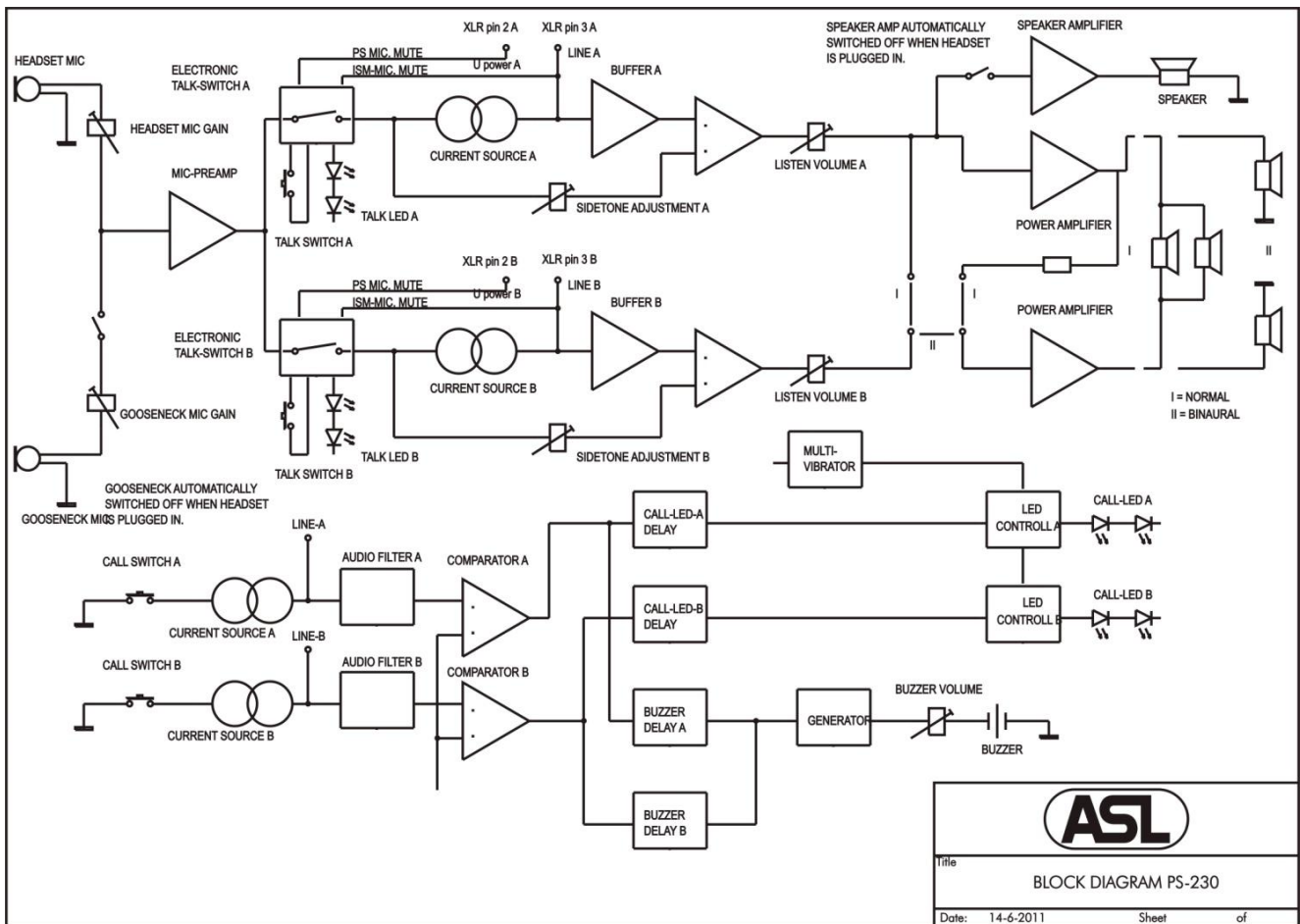

12.0 SYSTEM CONFIGURATION

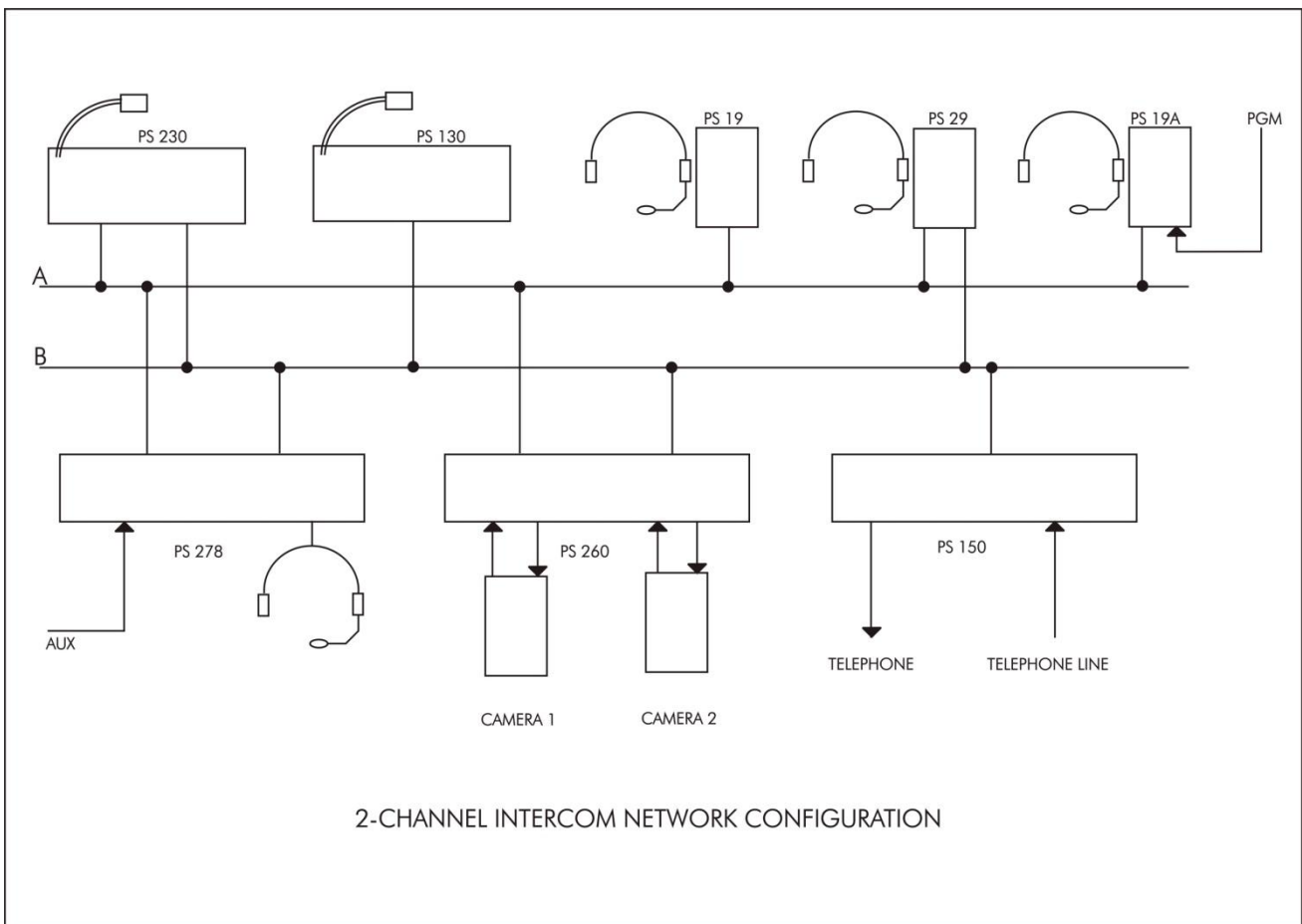

13.0 EARTHING CONCEPT

