

# Installation & Operating Manual

## XXV Pellet Stove Owners Manual

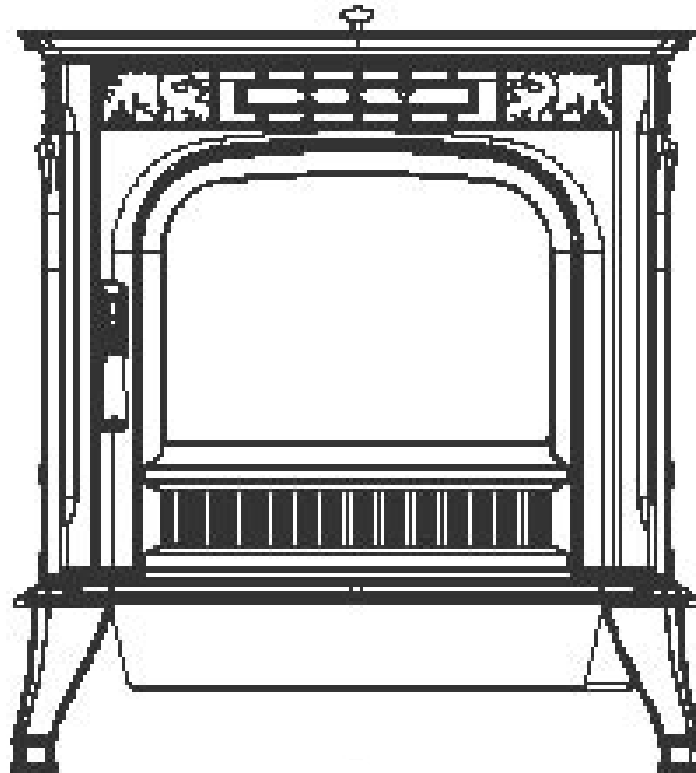

Tested by:

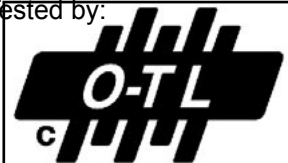

R1  
6/17/05

### SAFETY NOTICE

PLEASE READ THIS ENTIRE MANUAL BEFORE YOU INSTALL AND USE YOUR NEW ROOM HEATER. FAILURE TO FOLLOW INSTRUCTIONS MAY RESULT IN PROPERTY DAMAGE, BODILY INJURY, OR EVEN DEATH.

FOR USE IN THE U.S. AND CANADA. SUITABLE FOR INSTALLATION IN MOBILE HOMES.

IF THIS HARMAN STOVE IS NOT PROPERLY INSTALLED, A HOUSE FIRE MAY RESULT. FOR YOUR SAFETY, FOLLOW INSTALLATION DIRECTIONS.

CONTACT LOCAL BUILDING OR FIRE OFFICIALS ABOUT RESTRICTIONS AND INSTALLATION INSPECTION REQUIREMENTS IN YOUR AREA.

CONTACT YOUR LOCAL AUTHORITY (SUCH AS MUNICIPAL BUILDING DEPARTMENT, FIRE DEPARTMENT, FIRE PREVENTION BUREAU, ETC.) TO DETERMINE THE NEED FOR A PERMIT.

CETTE GUIDE D'UTILISATION EST DISPONIBLE EN FRANCAIS. CHEZ VOTRE CONCESSIONNAIRE DE

## SAVE THESE INSTRUCTIONS



# Introduction

Thank you for purchasing the Harman XXV Pellet Stove. The Harman XXV Pellet Stove is the culmination of elegance, convenience, functionality and dependability

The XXV was thoughtfully designed to look captivating in every home. Intricately detailed oak leaves express the magnitude of craftsmanship that goes into making this stove a masterpiece. These beautiful castings are proudly made in the U.S.A.

Built to strict Harman standards, the XXV has the most advanced construction of any Harman Pellet Stove. This 25th Anniversary Stove is based on Harman's patented pellet stove technology and goes a few steps further. The glass hopper lid allows you to see the fuel level while the mirrored front glass transforms into clear glass with the radiance of the fire.

A new concept for the XXV is the ability to use the top vent option. Using this method, the XXV can easily replace a wood stove by placing the top vent adapter over the rear vent.

We put all of our favorite features into the XXV, fusing the highest caliber pellet stove innovations with the allure of cast iron.



Serial #:

This label is located on the back of the unit. Please copy the Serial Number for future reference.

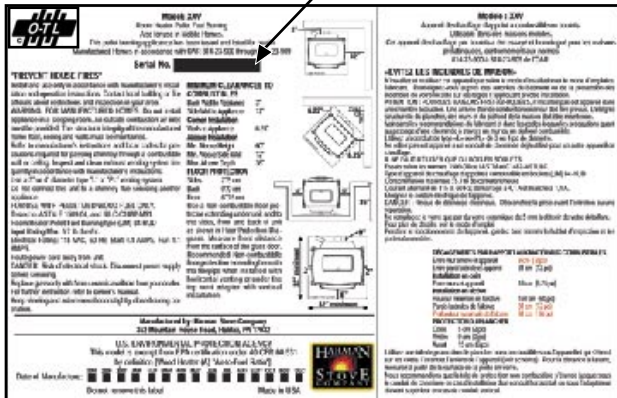

Please read this entire manual before you install and use your new room heater. Failure to follow instructions may result in property damage, bodily injury, or even death.

**Harman Stove Company**  
352 Mountain House Road  
Halifax, PA 17032

## Table of Contents

Assembly & Installation	4
Installation	5
Venting	6
Automatic Operation	14
Manual Operation	17
ESP Control	19
Low Draft Voltage Adjustment	20
Room Sensor	21
Maintenance	22
Trouble Shooting	26
Feeder Parts	27
Specifications	27
Options	28
Wiring Diagram	29
Parts List	30
Warranty	30

# IMPORTANT NOTES

## Flame Guide

Install the cast iron flame guide on top of the burn pot. Make sure that the flame guide is fully seated on the vertical sides of the burn pot and that the back of the guide rests against the burn pot mounting flange.

INSTALL EXHAUST VENT CLEARANCES SPECIFIED BY THE MANUFACTURER. Most pellet pipes require a minimum of 3" of clearance to combustible materials.

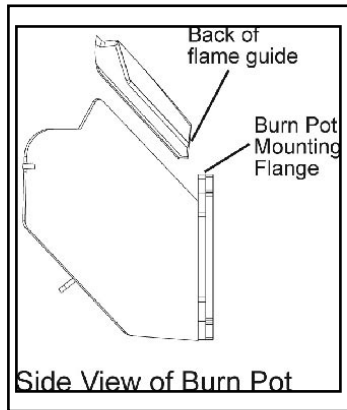

**DO NOT INSTALL A FLUE DAMPER IN THE EXHAUST VENTING SYSTEM OF THIS UNIT.**

**DO NOT CONNECT THIS UNIT TO A CHIMNEY FLUE SERVING ANOTHER APPLIANCE.**

Mobile home installation should be done in accordance with the Manufactured Home and Safety Standard (HUD), CFR 3280, Part 24.

## WARNING

**DO NOT INSTALL IN SLEEPING ROOM**

## CAUTION

**THE STRUCTURAL INTEGRITY OF THE MOBILE HOME FLOOR, WALL, AND CEILING/ROOF MUST BE MAINTAINED.**

## CAUTION

**KEEP COMBUSTIBLE MATERIALS (SUCH AS GRASS, LEAVES, ETC.) AT LEAST 3 FEET AWAY FROM THE FLUE OUTLET ON THE OUTSIDE OF THE BUILDING.**

## CAUTION

**HOT WHILE IN OPERATION. KEEP CHILDREN, CLOTHING AND FURNITURE AWAY. CONTACT MAY CAUSE SKIN BURNS.**

# Assembly and Installation

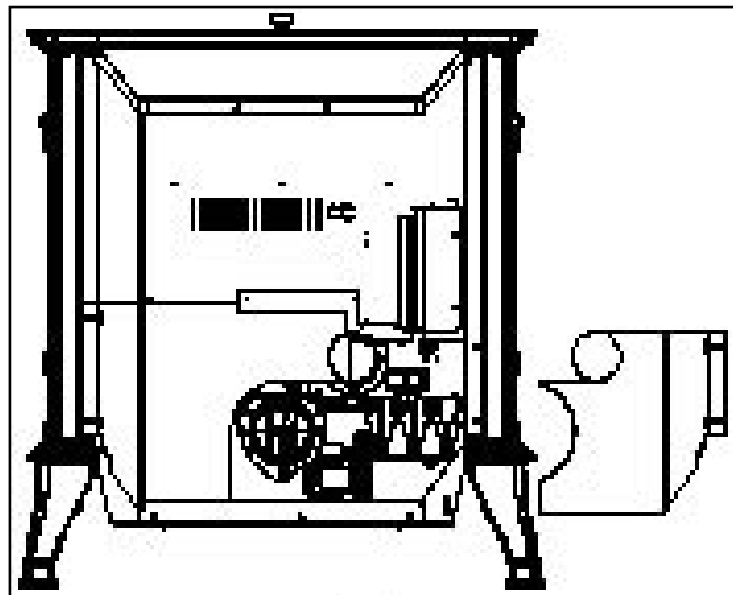

Figure 1

The power cord is tucked inside left rear cover panel. To remove cord, Loosen the two 5/16" hex heads and slide panel outward.

# Installation

## Installing

Place the stove on a noncombustible floor protector that extends a minimum of 6 inches to the front, 2 inches to the sides and flush with the rear of the hopper. Ash protection must also be positioned under any horizontally run flue pipe. The minimum floor protector material is 20 gauge sheet metal. Other floor protector materials are ceramic tile, stone, brick, etc.

Place the stove away from combustible walls at least as far as shown in Figures 2, 3 and 4.

Note that the clearances shown are minimum for safety but do not leave much room for access when cleaning or servicing. Please take this into account when placing the stove.

Connect the power cord to a 120 V.A.C. 60Hz grounded receptacle. (A surge protector is recommended to protect the circuit board.) If the voltage entering your home is below 116 volts your stove may not work properly. Also be sure that the polarity of the outlet that the stove is plugged into is correct.

Prior to installing the flue pipe, connect a draft meter. (The draft meter must have a minimum range of 0-.5.) Record the first reading. Connect flue pipe to stove and be sure all doors and windows in the home are closed. Record the second draft reading \_\_\_\_\_. If the second reading is more than .05" lower than the first reading, check for possible restrictions or the need for outside air (see page 8). For more information on the draft test procedure, refer to Page 20.

## Mobile Home Installation

When installing this unit in a mobile home several requirements must be followed (Reference HUD Regulation #24CFR3280):

1. The unit must be bolted to the floor. This can be done by using clips (part # 2-0-677110) and 1/4" lag screws.
2. The unit must also be connected to outside air. See page 8.
3. Floor protection and clearances must be followed as shown.
4. Unit must be grounded to the metal frame of the mobile home.

**CAUTION: This appliance must be vented to the outside.**

Due to high temperatures, the stove should be placed out of traffic and away from furniture and draperies.

Children and adults should be alerted to the hazards of high surface temperatures and should stay away to avoid burns to skin and/or clothing.

Young children should be carefully supervised when they are in the same room as the stove.

Clothing and other flammable materials should not be placed on or near this unit.

Installation and repair of this Harman stove should be done by a qualified service person. We recommend that the stove be inspected before use and at least annually by a qualified service person. Periodic cleaning is required throughout the heating season and at the end of each winter for the stove to work efficiently. See cleaning instructions on page 21.

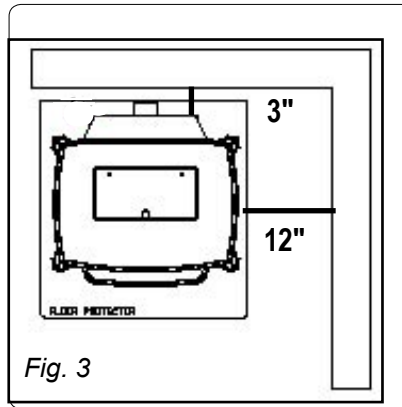

Fig. 3

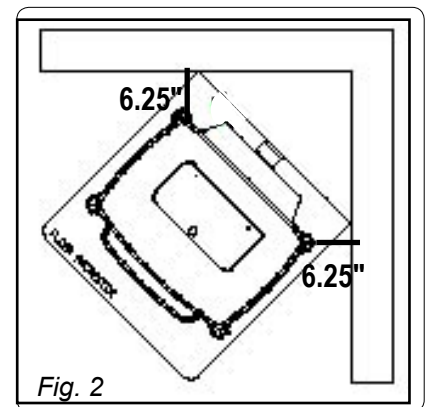

Fig. 2

**Floor Protection** must be 2 inches to each side, 6 inches to the front, and 0 inches to the back of the stove. Floor Protector minimum: 32" wide x 32" deep.

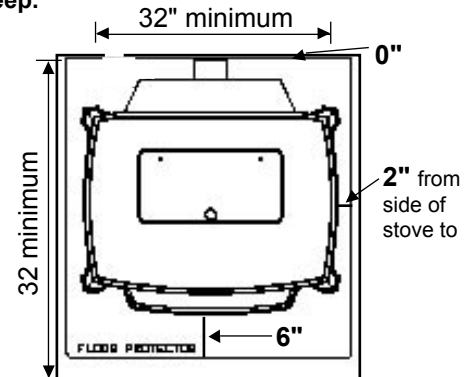

Fig. 4

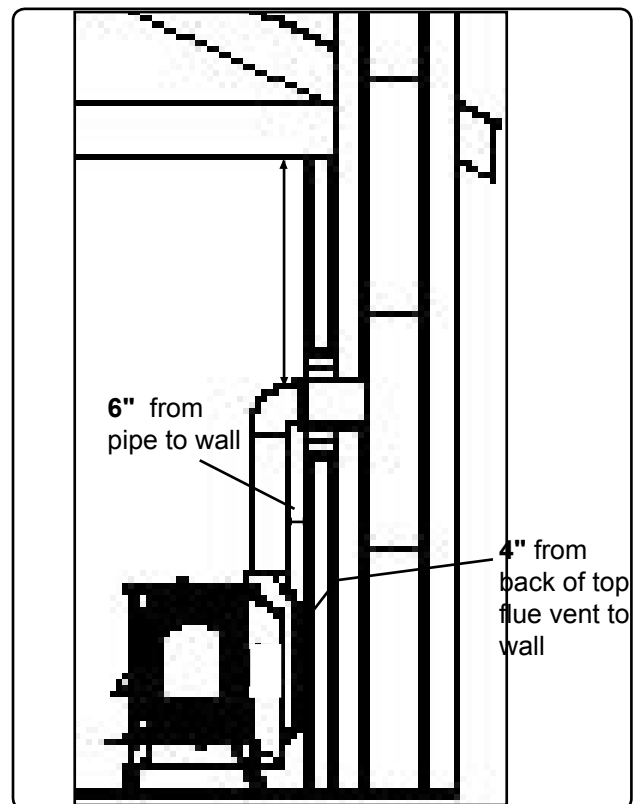

Fig. 5: Optional Top Vent Pipe Clearances

# Venting

## Requirements for Terminating the Venting

**WARNING:** Venting terminals must not be recessed into a wall or siding.

**NOTE:** Only the Harman Direct Vent Wall Pass-through (part # 1-00-677077) or PL listed vent pipe wall pass-throughs and fire stops should be used when venting through combustible materials.

**NOTE:** Always take into consideration the effects of the prevailing wind direction or other wind currents that may cause flyash and/or smoke when placing the termination vent.

**In addition, the following must be observed:**

A. The clearance above grade must be a minimum of 18".<sup>1</sup>

B. The clearance to a window or door that may be opened must be a minimum of 48" to the side, 48" below the window/door, and 12" above the window/door.<sup>1</sup>

(with outside air installed, 18")

C. A 12" clearance to a permanently closed window is recommended to prevent condensation on the window.

D. The vertical clearance to a ventilated soffit located above the terminal within a horizontal distance of 2 feet (60 cm) from the center-line of the terminal must be a minimum of 18".

E. The clearance to an unventilated soffit must be a minimum of 12".

F. The clearance to an outside corner is 11" from center of pipe.

G. The clearance to an inside corner is 12".

H. A vent must not be installed within 3 feet (90 cm) above a gas meter/regulator assembly when measured from the horizontal center-line of

the regulator.<sup>1</sup>

I. The clearance to service regulator vent outlet must be a minimum of 6 feet.<sup>1</sup>

J. The clearance to a non-mechanical air supply inlet to the building or the combustion air inlet to any other appliance must be a minimum of 48".<sup>1</sup>

K. The clearance to a mechanical air supply inlet must be a minimum of 10 feet.<sup>1</sup>

(with outside air installed, 6 feet)

L. The clearance above a paved sidewalk or a paved driveway located on public property must be a minimum of 7 feet.<sup>1,2</sup>

M. The clearance under a veranda, porch, deck or balcony must be a minimum of 12 inches.<sup>1,3</sup>

**NOTE:** The clearance to vegetation and other exterior combustibles such as mulch is 36" as measured from the center of the outlet or cap. This 36" radius continues to grade or a minimum of 7 feet below the outlet.

<sup>1</sup>Certain Canadian and or Local codes or regulations may require different clearances.

<sup>2</sup>A vent shall not terminate directly above a side-walk or paved driveway which is located between two single family dwellings and serves both dwellings.

<sup>3</sup>Only permitted if veranda, porch, deck, or balcony is fully open on a minimum of 2 sides beneath

**NOTE: Where passage through a wall, or partition of combustible construction is desired, the installation shall conform to CAN/CSA-B365. (if in Canada)**

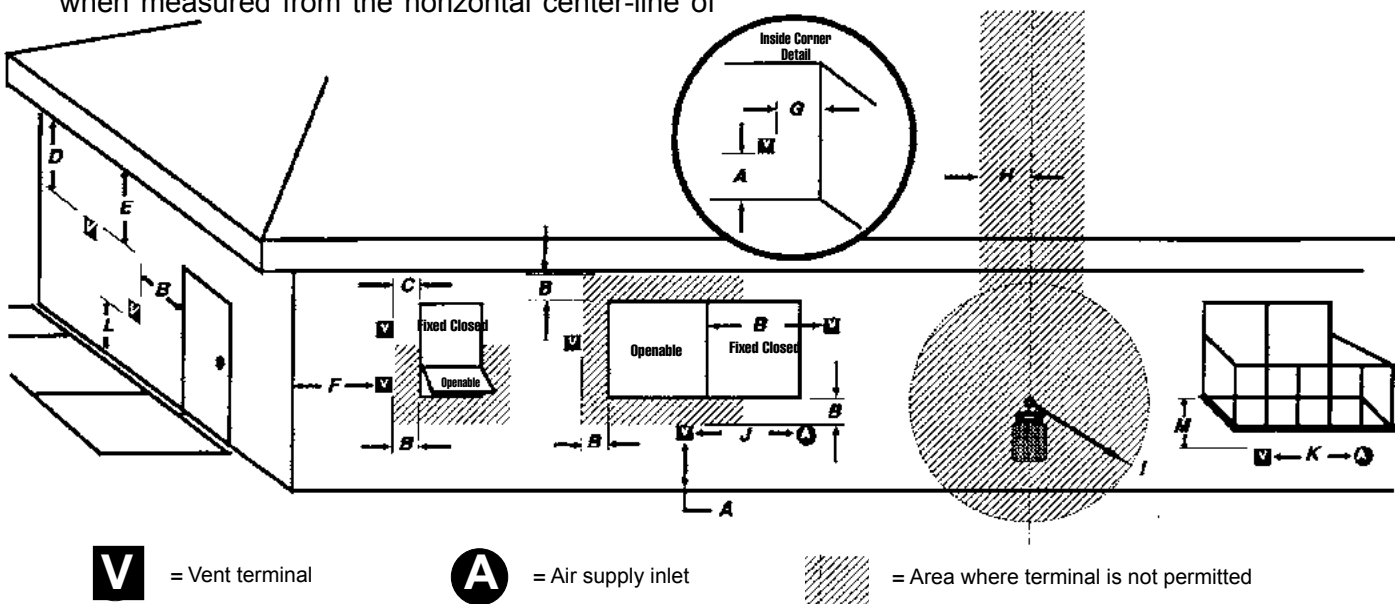

# Venting

## **IMPORTANT NOTICE**

Pellet Vent Pipe or PL Vent Pipe Must Be Used unless the unit is being installed with the optional top 6" Flue Adapter.

If using 6" Flue Adapter, it is recommended to use a sealed seam 6" flue pipe (snaplock seam is not recommended) and seal the joints with high temperature silicone.

In some cases it may be necessary to use a liner in the existing chimney to obtain proper draft.

## **CAUTION**

**Do not connect to any air distribution duct or system.**

## Venting

A combustion blower is used to extract the combustion gases from the firebox. This causes a negative pressure in the firebox and a positive pressure in the venting system as shown in Fig. 6. The longer the vent pipe and more elbows used in the system, the greater the flow resistance. Because of these facts we recommend using as few elbows as possible and 15 feet or less of vent pipe. The maximum horizontal run should not exceed 48". If more than 15 feet of pipe is needed, the interior diameter should be increased from 3" to 4" because a larger pipe causes less flow resistance. **Be sure to use approved pellet vent pipe wall and ceiling pass-through fittings to go through combustible walls and ceilings.** The use of a starting collar is not always necessary. The first piece of pipe should be fastened securely with at least 2 fasteners to the flue collar of the stove. If a starting collar is used to attach the venting system to the stove, **the starting collar must be sealed to the stove with high temp silicone caulking.**

## Vent Pipe

Pellet venting pipe (also known as PL vent ) is constructed of two layers with air space between the layers. This air space acts as an insulator and reduces the outside surface temperature to allow a clearance to combustibles of only 3 inches. The sections of pipe lock together to form an air tight seal in most cases. However, in some cases a perfect seal is not achieved. For this reason and the fact that the XXV operates with a positive vent pressure we specify that the **joints also be sealed with silicone.** Aluminum tape can also be used for any joint that is 1 ft. or more from the outlet of the stove.

When using the top vent option, 6 inch single wall pipe must be connected with at least three (3) screws. Also, the joints must be sealed with high temperature silicone.

We cannot emphasize enough, the importance of sealing every seam and joint in the venting system which is inside the home. Even the smallest pin hole can leak and when it does you will smell wood smoke or a creosote smell in the room. If this occurs check for leaks. Leaks are easiest to see during start-up. Alternatively you can use a smoke pellet to leak test the venting before lighting your first fire.

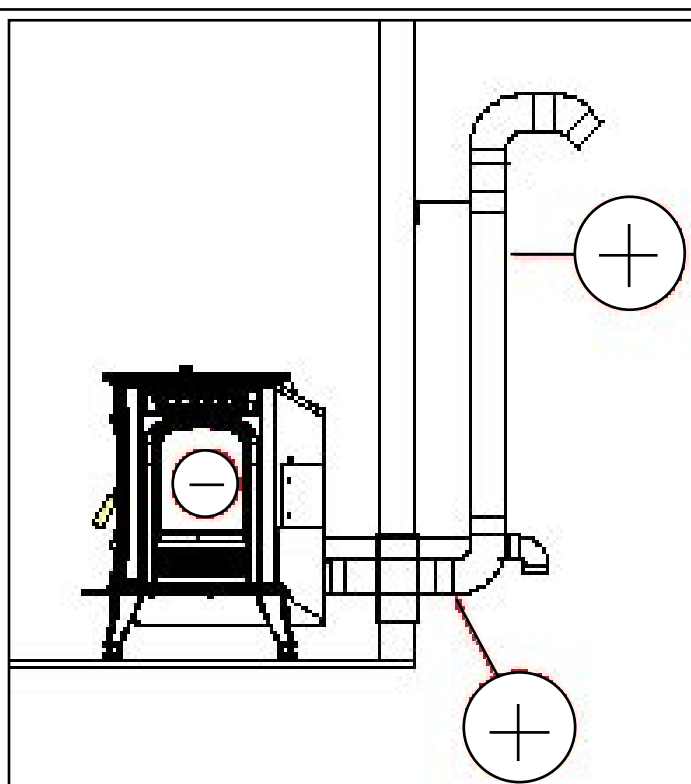

- ⊕ = Positive Static Pressure
- ⊖ = Negative Static Pressure

Fig. 6



# Venting

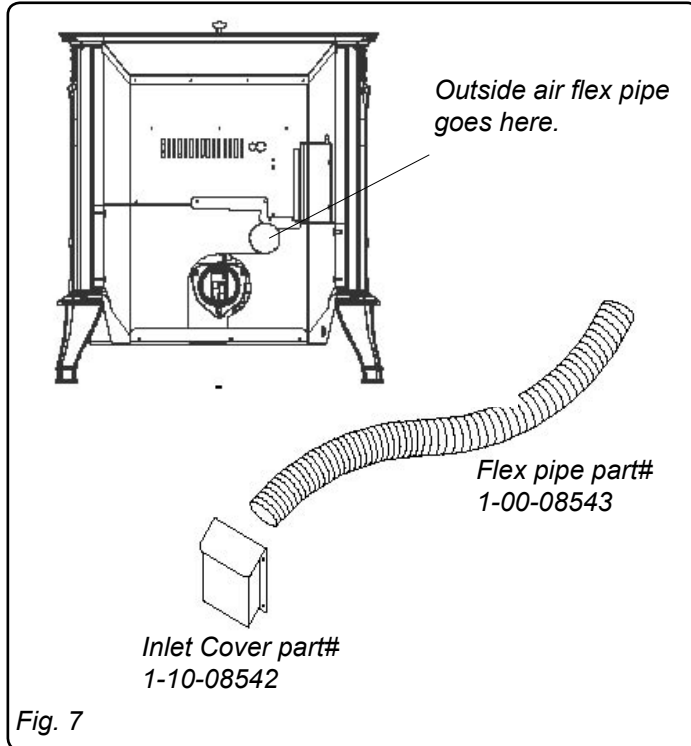

## Outside Air

Here are four benefits of outside air:

1. Having air introduced from outside the living area boosts overall efficiency.
2. It eliminates draft problems that can occur in tight homes.
3. It reduces smoke spillage in the event of a power failure.
4. It allows your vent termination to be as close as 18" from windows or doors.

Outside air is optional except in mobile homes and where building codes require. The benefit of outside air is mainly noticed in small, very tight, houses.

To install outside air use 2 3/8" I.D. non-combustible flex pipe. There is a break-away hole on the rear panel of the XXV stove which must be removed before connecting the flex pipe. The pipe should be run outside and terminate to the side or below the vent pipe outlet so the flue outlet is more than 12" from the inlet cover. The maximum length run of this pipe is 15 feet. If a longer run is needed the size must be increased to 3". Inlet cover part number 1-10-08542 should be used to keep birds, rodents, etc. out of the pipe unless the Harman wall passthrough is being used.

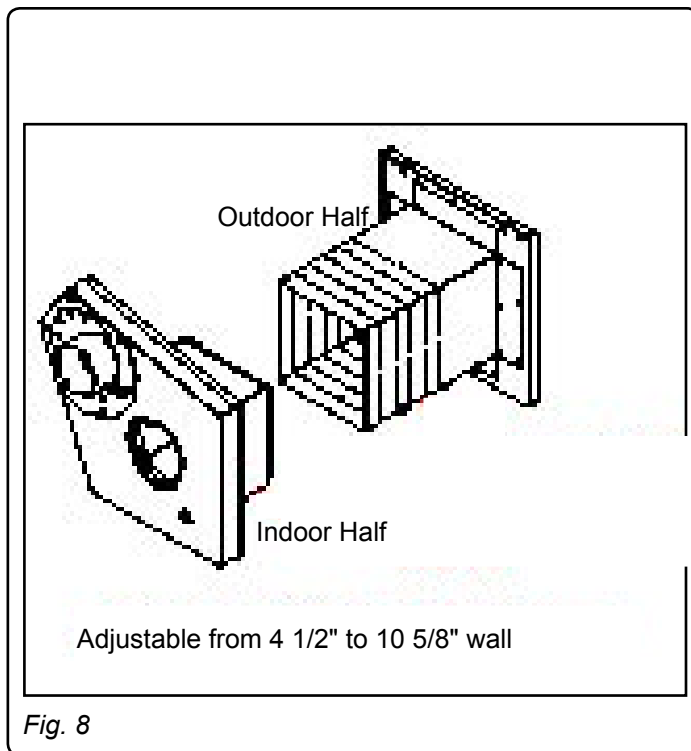

## HRV

When installing in a house with a Heat Reclaiming Ventilation System (HRV) be sure the system is balanced and is not creating a negative pressure in the house.

## Direct Vent Wall Passthrough

The Harman Direct Vent Wall Passthrough (Part # 1-00-677077) makes installing your Harman Pellet Stove with outside air a lot easier. It is made to fit walls from 4 1/2" up to 10 1/8" thick with a square opening of 6" to 6 1/2".



# Venting

## NOTICE

A chimney connector shall not pass through an attic or roof space, closet or similar concealed space, or a floor, or ceiling.

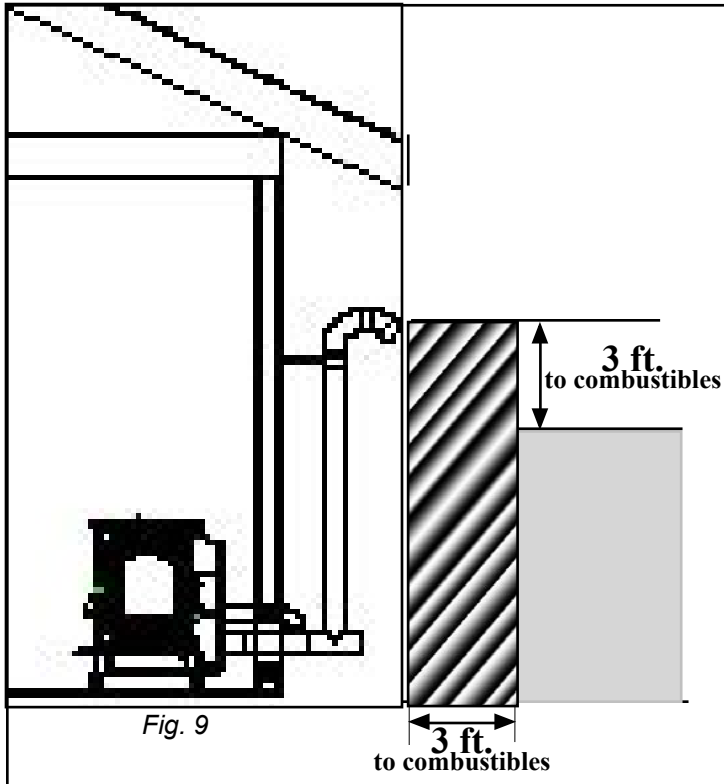

### #1 Preferred method (Fig. 8)

This method provides excellent venting for normal operation and allows the stove to be installed closest to the wall. Two inches from the wall is safe; however, four inches allows better access to remove the rear panel. The vertical portion of the vent should be three to five feet high. This vertical section will help provide natural draft in the event of a power failure. **Note: Do not place joints within wall pass-throughs.**

### #2 Preferred method (Fig. 9)

This method also provides excellent venting for normal operation but requires the stove to be installed farther from the wall. The vertical portion of the vent should be three to five feet high and at least three inches from a combustible wall. This vertical section will provide natural draft in the event of a power failure.

If the stove is installed below grade be sure the vent termination is at least 18" above grade. The outlet must also be 1 foot from the house/building.

**Note: Do not place joints within wall pass-throughs.**

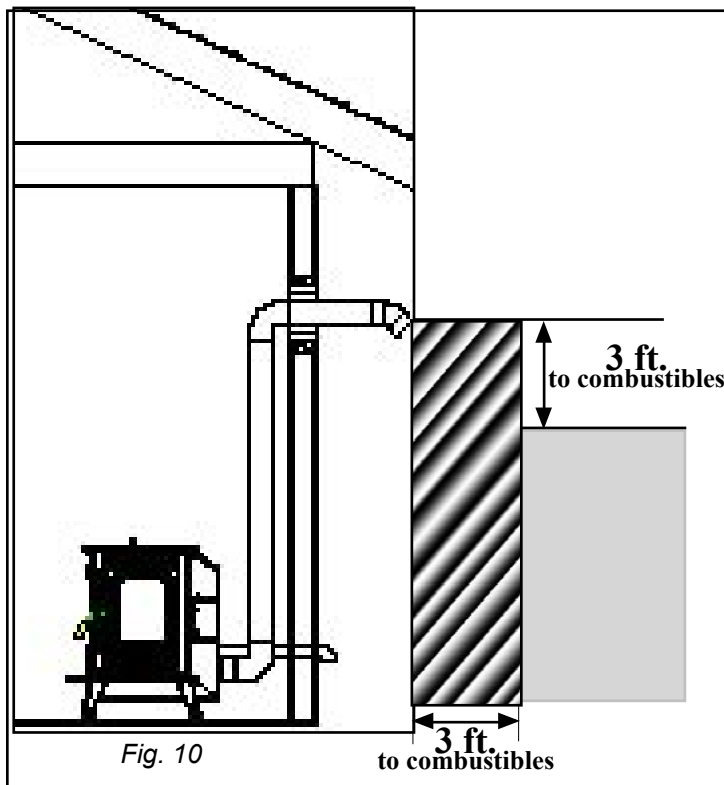

## CAUTION

Keep any materials that may be affected by the elevated exhaust temperatures at least 3 feet away from the flue termination.

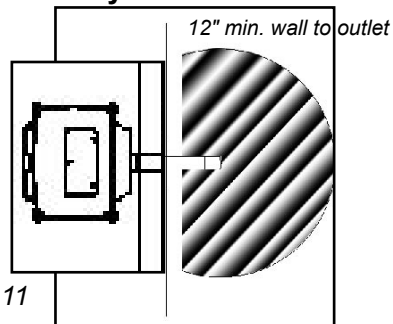

# Venting

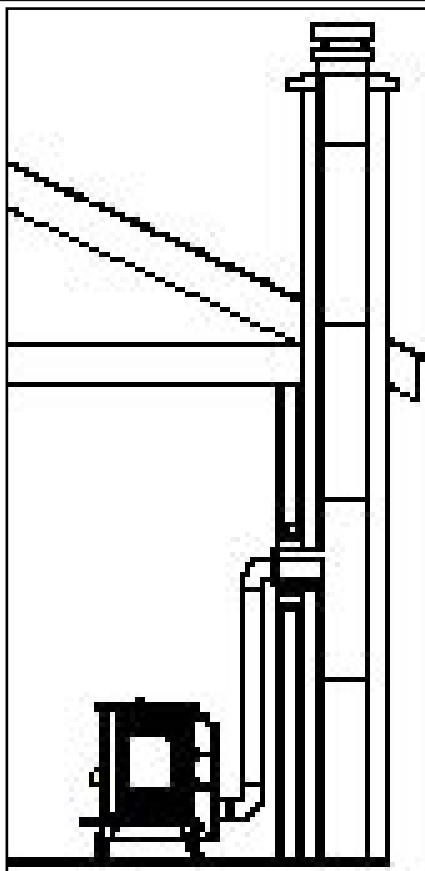

Fig. 12

## #3 Installing into an existing chimney

This method provides excellent venting for normal operation. This method also provides natural draft in the event of a power failure. If the chimney condition is questionable\* you may want to install a liner as in method #6.

\*The chimney should be inspected and cleaned before installing your stove. If you discover that the chimney does not have a clay tile liner or has cracks or flaking of the tile liner you will need to install a stainless steel liner within the chimney. In most cases the inside diameter of this liner should be 4". Either flexible or rigid liner may be used for this purpose. Refer to Method 6.

Be sure to design the venting so that it can be easily cleaned.

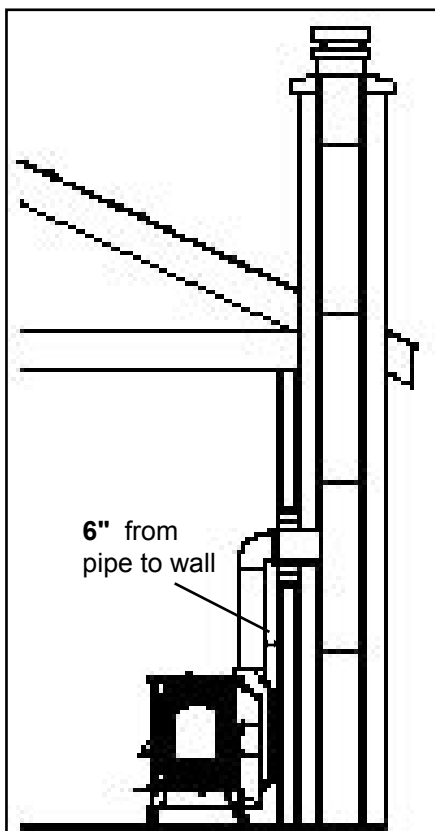

Fig. 13

## #4 Installing into an existing chimney with optional top discharge 6" flue adapter

This method will allow single wall 6" flue pipe to come off the top of the stove and go directly into a masonry or class A chimney.

This method will be desirable for people who are replacing a wood or coal stove and have an existing chimney to use.

# Venting

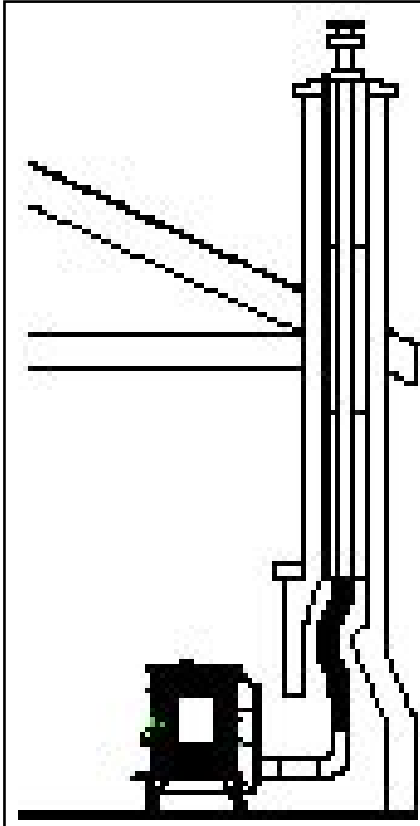

Fig. 14

## #5 Installing into an existing fireplace chimney (US and Canada)

This method provides excellent venting for normal operation. This method also provides natural draft in the event of a power failure.

In Canada and some places in the US it is required that the vent pipe extend all the way to the top of the chimney. Per ULC S628.

In this method a cap should also be installed on the chimney to keep out rain. Be sure to use approved pellet vent pipe fittings. Seal pipe joints with silicone or aluminum tape in addition to the sealing system used by the manufacturer. Pipe size should be increased to 4" using this method.

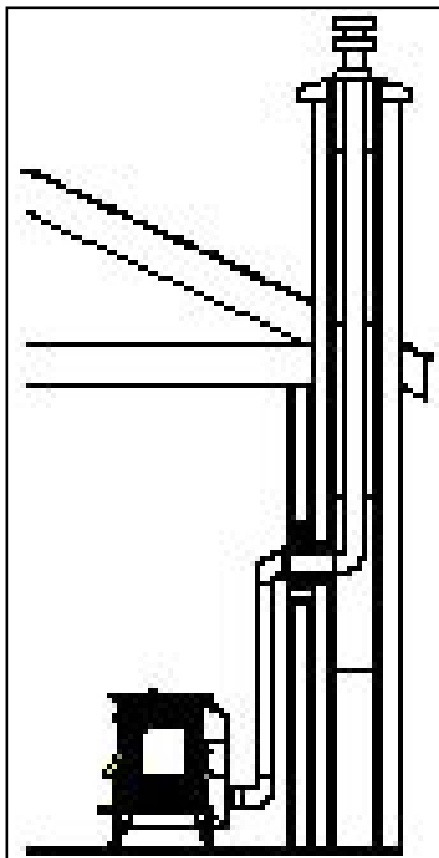

Fig. 15

## #6 Installing into an existing chimney (US and Canada)

This method provides excellent venting for normal operation. This method also provides natural draft in the event of a power failure.

In this method a cap should also be installed on the chimney to keep out rain.

# Venting

## #7 Installing into an existing chimney using 3" pl vent in combination with 6" or 8" single or double wall stove pipe.

This method allows the installer to use 6" or 8" single and double wall stove pipe ( sealed seam not snap lock ) and an existing masonry or class A chimney to vent the stove.

The stove must use a pl type pellet vent and 90 degree elbow to start at the stove connector and then use the approved pipe adapter to connect to the size of vent that continues into the chimney connector. Support of the assembly must follow any pipe and connector manufacturers recommendations

Pipe manufacturer clearance to combustibles, NFPA and or any local codes must be followed for this type of installation. Be sure to check with the pipe manufacturer for clearance to combustibles.

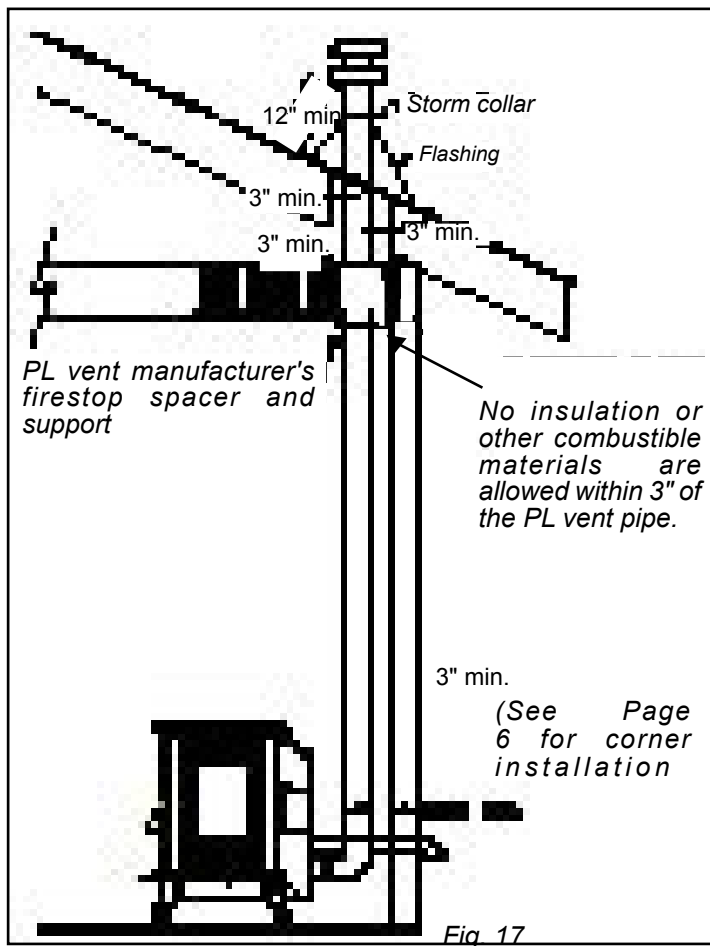
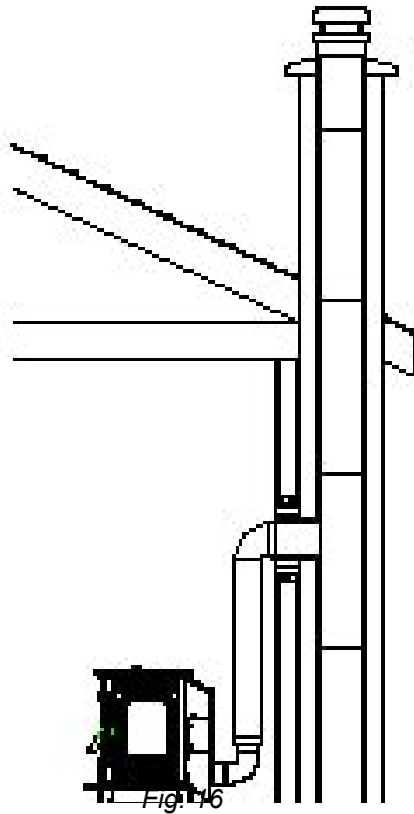

## #8 Installing through the ceiling

Through the ceiling vent, follow PLvent manufacturers recommendations when using a wall or ceiling pass through. **Note: Do not place joints within wall pass-throughs.**

# Venting

## Minimum flue vent configuration

It is recommended that outside air be installed with this venting configuration to reduce smoke and creosote smell in the room in the event of power failure.

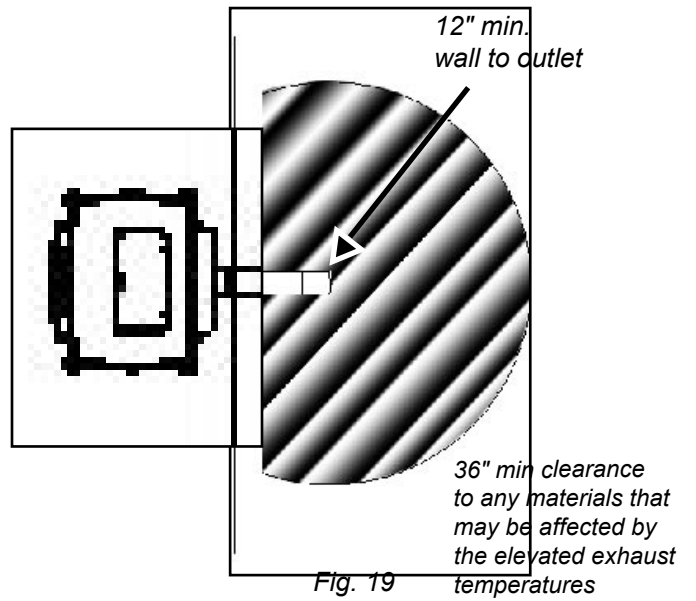
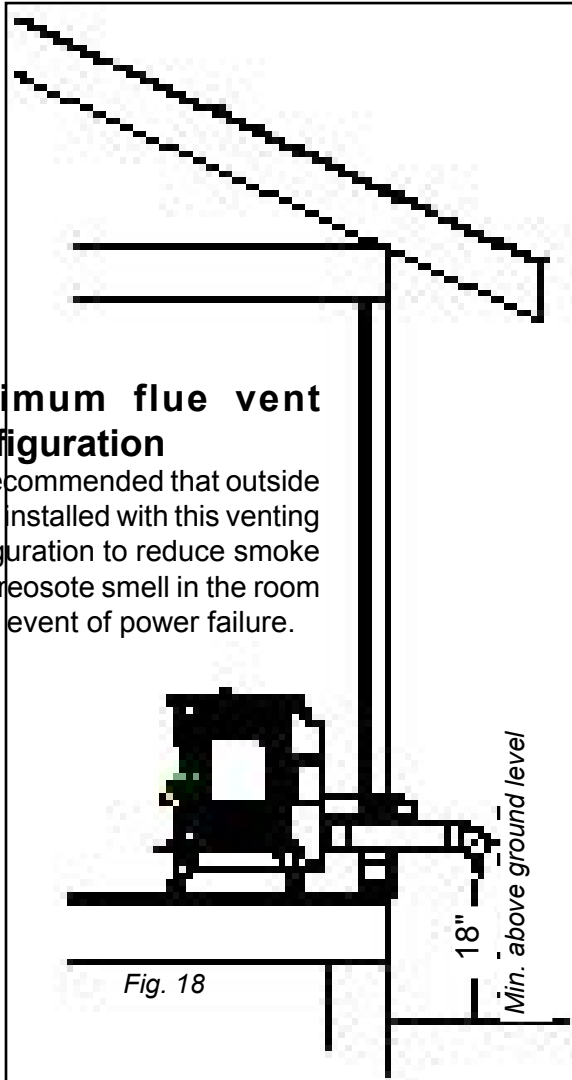

# AUTOMATIC IGNITION/OPERATION

The XXV is a fully automatic stove that features two operating modes; **Stove Temperature Mode** and **Room Temperature Mode**. In Stove Temperature Mode, you select a burn rate and the stove will remain at the same burn rate regardless of the room temperature.

In the Room Temperature Mode the stove constantly monitors the temperature in the room and adjusts the size of the fire and the heat output of the stove so that the room is kept at a constant temperature. Room Temperature Mode, in the AUTO position, has the added advantage of turning the stove off if no heat is required and turning the stove on again when the room temperature drops below your desired room temperature set point.

## Room Temperature Mode

Most consumers use the stove in the Room Temperature Mode because it is the easiest and most efficient method of keeping the room at a given temperature. In the Room Temperature Mode, the Room Sensing Probe constantly monitors room temperature. As the weather changes outside and your home needs varying amounts of heat to be at a desired temperature, the stove will automatically adjust size and heat output of the fire so that a constant even temperature is maintained. If the weather warms up and no heat is required the stove will gradually shut down. When the house cools down the stove will automatically bring the room temperature to your desired setting

In the Room Temperature Mode you can select either **Auto or Manual modes** for the **igniter** using the igniter toggle switch. When the toggle switch is in the Auto position the igniter located inside the burn pot is ready to automatically light the fire when required. When the toggle switch is set to the Manual position the stove can be lit manually with either a gel or a wax type fire starter. (see lighting instructions on page 18.) With the igniter toggle switch set in the Manual position the stove will automatically adjust heat output, but the stove will not automatically shut down if no heat is required. Instead it will go to its lowest setting and remain there. The Manual position on the igniter toggle switch lets you light the stove manually, should the igniter fail for any reason. Secondly if you are using the Harman battery back up system the Manual setting will prevent the stove from turning off and on during a power failure, which would drain the back up battery, and possibly cause damage to the back-up or the stove.

In the Room Temperature Mode, the distribution blower speed can be increased or decreased by adjusting the Room Temp/Off/Stove Temp dial between L and H. As output of the stove increases, the speed of the blower will increase automatically to insure that more heat is transferred out into the room. The distribution blower will shut off as the room reaches the set temperature, this will prevent overheating of the room.

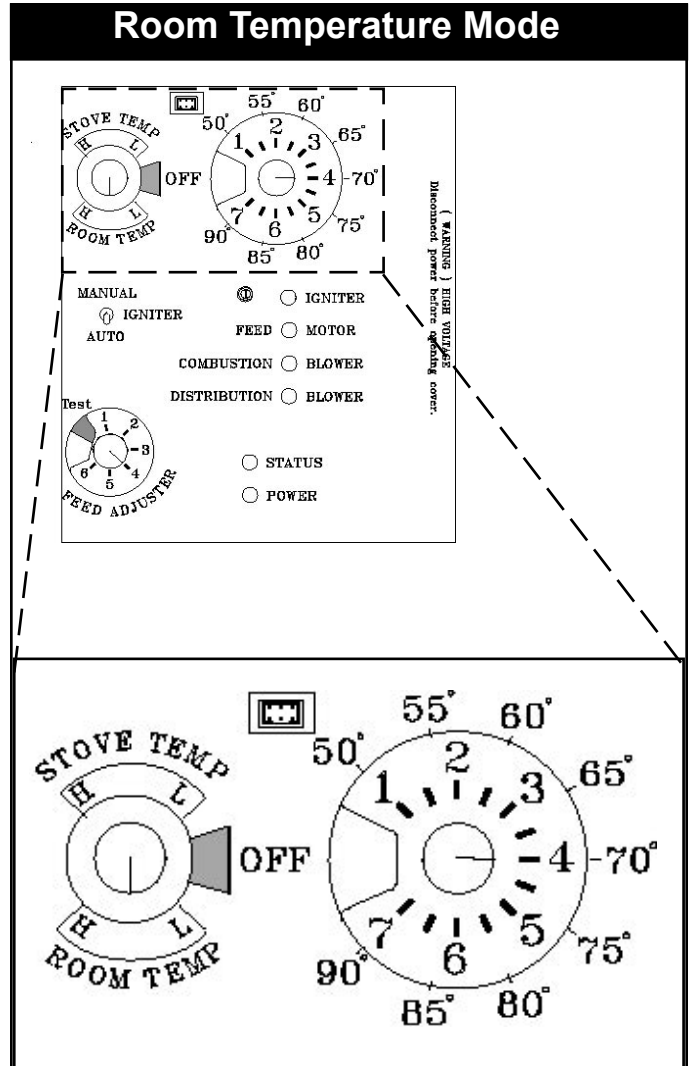

Fig. 20

**Room Temperature Mode:** This setting, see above, will produce a room temperature of 70 degrees with the distribution blower at medium speed.

# AUTOMATIC IGNITION/OPERATION

## Stove Temperature Mode

In the Stove Temperature Mode and with the igniter toggle switch in the Auto position, the stove will light automatically and can be adjusted to the desired setting using the same temperature control dial as is used in the Room Temperature Mode. The heat output and fuel consumption will remain constant regardless of room temperature. The settings from 1 to 7 on the inner ring of the dial provide for relative heat output settings with 1 being low and 7 being the maximum.

In Stove Temperature Mode the stove will not automatically shut off unless the stove runs out of fuel or is turned off.

Never disconnect the powercord to shut down the stove. This will stop the combustion blower and smoke will escape through window and door gaskets.

When the igniter toggle switch is set to manual in this mode, the distribution blower will not turn on with a temperature dial setting from 1 to 5. The advantage of this mode is to allow the operator to have a large viewing fire without blowing extra heat into the room.

During operation, with the temperature dial set at around #5 or less, the distribution fan will not operate. A #5 on the temperature dial and a #5 on the feed adjuster is approximately 80% output. It is not necessary to operate the distribution blower below this point. Therefore, the control allows a higher burn rate ( a larger viewing fire) without an excess of hot air blowing into the room.

An example of when to use the Manual Stove Temperature Mode is if you want to watch a large fire and the room is already up to temperature. The Stove Temperature Mode allows you to have a larger fire and a lower sound level, without the distribution blower.

**NOTE: During the use of this mode, if you keep increasing the temperature dial setting to increase the fire size, the distribution blower will automatically come on when the ESP Temperature reaches 350° F, or 81% output.**

### Feed Adjuster Knob

For most premium grade pellet fuels the Feed Adjuster Knob should be set at 4. If higher ash fuels are used the setting should be increased to 5 or 6. Also higher settings are required if you would like to get the maximum heat output from the stove. At the maximum burn rate (with the temperature dial on 7/90° and the feed adjuster at 6) there should be 1" or more of ash on the front of the burn pot. If there is less than 1" of ash, turn the feed adjuster knob down to a lower setting.

## Shut Down Procedure

The best way to shut down the stove is simply let it run out of pellets, the stove will shut down automatically. Alternatively, you can turn the Mode Selector to "off". This will cause the fire to gradually die down and go out. The fire will not go out immediately and may take more than an hour to fully shut down.

If the stove is left to run out of fuel, you may get a 6 blink status light. If this happens simply reset the control board by turning the mode selector to OFF and back ON.

### Stove Temperature Mode

The diagram illustrates the stove temperature control dial with two settings. The dial has an outer ring with temperature markings (50°, 55°, 60°, 65°, 70°, 75°, 80°, 85°, 90°) and an inner ring with heat output settings (1, 2, 3, 4, 5, 6, 7). A mode selector knob is shown in the 'OFF' position. The top diagram shows the dial set to 4 (70°F) and the bottom diagram shows the dial set to 6 (80°F).

*The setting, see above, will produce continuous medium heat output with the distribution blower at low speed.*

*This setting, see above, will produce continuous maximum heat output with the distribution blower at full speed.*

Fig. 21



# AUTOMATIC START UP

## Starting Fire

### Igniter Switch to "AUTO"(up position)

Make sure the unit is plugged into a 120 VAC, 60 HZ electrical source. The power light should be the only light lit.

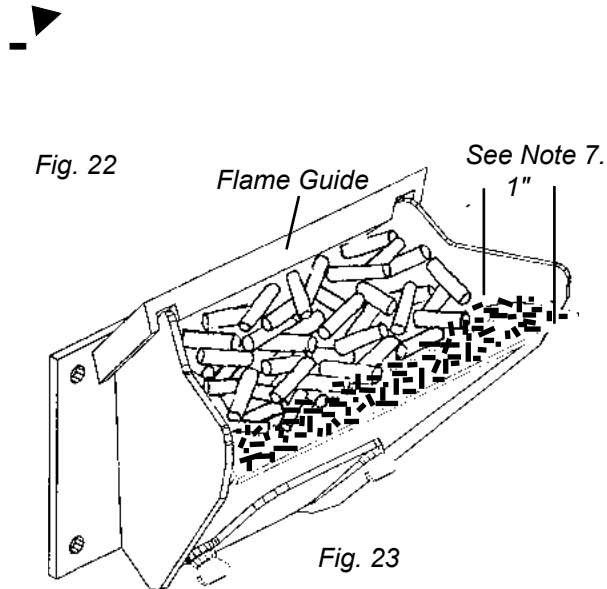

1. Turn Mode Selector to "OFF".
2. Fill hopper with pellets.<sup>1</sup>
3. Clean burn pot with scraper, if necessary.<sup>5</sup>
4. If starting after an empty hopper, turn Feed Adjuster to "TEST" (for one 60 second cycle).<sup>2</sup> This will purge pellets into the auger tube and also allow you to check the motors for operation.  
**NOTE: The auger motor will not operate with the view door or ash pan door open.**<sup>3</sup>
5. Turn Feed Adjuster to #4.<sup>4</sup>
6. Flip the Igniter Switch up into the "AUTO" position.
7. Turn the Temperature Dial to desired room temperature.
8. Turn Mode Selector to Room Temperature or Stove Temperature.
9. Fill hopper with pellets and remove ashes as required.<sup>6</sup>

### Helpful Hints

1. Fines are small pieces of broken pellets (sawdust). Fines do not flow easily and often build up on the hopper funnel bottom angles. You can push these fines into the feeder opening and then fill the hopper with pellets. As the system works, they will be burned. Or you can clean them out before filling the hopper.
2. The "TEST" cycle will operate the feeder motor for exactly one minute. Turning to "TEST" again and again may purge too much fuel into the burn pot causing excessive smoke on start-up.
3. The firebox low pressure switch will not allow the auger motor or the igniter element to operate if the view door or the ash pan door are open.
4. Adjust Feed Rate. If this is your first fire or you are trying different pellets, set the feed adjuster to #4, Fig. 22. This is a conservative number and will probably need to be increased. After you know a feed rate setting that works well, use that setting. Remember, if your feed rate is too high you may waste fuel.
5. This is usually a weekly maintenance procedure. Cleaning the burn pot with the scraper with a small amount of new fuel in the bottom is not a problem. First, scrape the ashes on the front of the burn pot into the ash pan. Then, scrape the top surface of the burn pot downward into the base of the burn pot. When the stove is ignited these scrapings will be pushed out by the feeder and burned.
6. The ash pan can hold the ashes from approximately 1 ton of premium fuel. This means the ashes will only need to be emptied a few times a year.
7. Setting the feed adjuster # for maximum burn: With the unit burning in "AUTO", turn to "Stove Mode" and put the fan on "H". Set the Temperature Dial to #7. Allow the unit to burn for about 30 minutes and check ash on front of burn pot. Fig. 23. If the ash line is larger than 1", turn the feed adjuster from #4 to #5. Allow another 30 minutes of burn time and check again. If, at #6 setting, a 1" or less ash bed is not obtainable, it is not a problem. The 1" ash bed is only a maximum burn rate and at most normal settings the ash bed will be larger.

## WARNING

"NEVER USE GASOLINE, GASOLINE-TYPE LANTERN FUEL, KEROSENE, CHARCOAL LIGHTER FLUID, OR SIMILAR LIQUIDS TO START OR "FRESHEN UP " A FIRE IN THIS HEATER. KEEP ALL SUCH LIQUIDS WELL AWAY FROM THE HEATER WHILE IN USE".

## WARNING

ONLY USE WOOD PELLET FUEL. DO NOT BURN GARBAGE IN STOVE.

# MANUAL IGNITION/OPERATION

The XXV Pellet Stove is capable of manual operation. This also allows the operator to manually control operation during an emergency (i.e. igniter failure, when using a 502H battery backup, or when using certain generators.)

The unit can be switched between "AUTO" and "MANUAL" at any time during operation.

**NOTE:** When starting the unit in the "AUTO" mode and switching to "MANUAL", the fire must be large enough to start the distribution blower. The starting of the blower is a signal that the start cycle is completed and the fire will not go out.

**Room Temperature Mode:** This setting, see below, will produce a room temperature of 70 degrees with the distribution blower at medium speed.

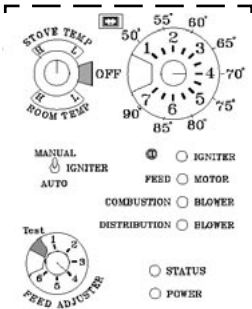

Always Pelletize with the feed cover closed. Disconnect power before opening cover.

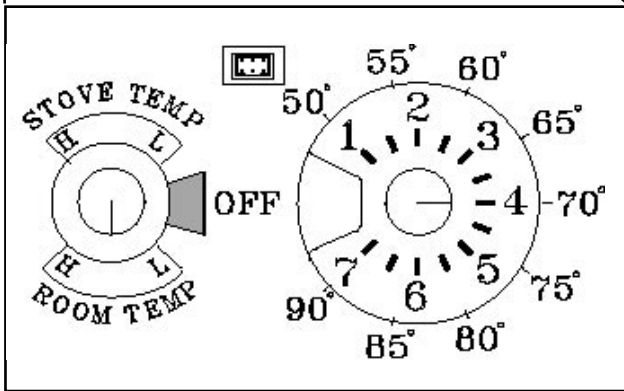

Fig. 24

## Igniter Switch to "MANUAL" Room Temperature Mode

The fire will have to be lit with starting gel and a match, or started automatically, see "Automatic Operation" on Page 15. Turn to "Manual" position when the fire is established.

The difference between "AUTO" Room Temperature Mode and "Manual" Room Temperature Mode is that the fire will not go out as the room temperature goes above the control board setting. The unit can only go to low burn and will remain there until it runs out of fuel or until more heat is needed and the feed rate increases. Feed rate adjustments and dial settings are the same as "AUTO" settings. The blower will shut off completely if the temperature on the ESP is too low.

## Manual Stove Temperature Mode

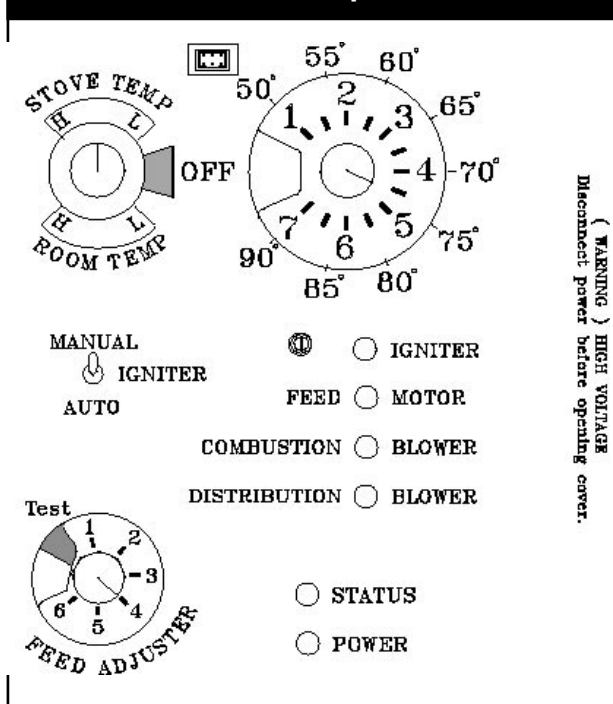

Fig. 25

This setting will produce a large viewing fire without a distribution blower operating.

## Igniter Switch to "MANUAL" Stove Temperature Mode

The advantage of this mode is to allow the operator to have a large viewing fire without blowing extra heat into the room.

During operation, with the temperature dial set at #5 or less, the distribution fan will not operate. A #5 on the temperature dial and a #5 on the feed adjuster is approximately 80% output. It is not necessary to operate the distribution blower below this point. This control setting allows a higher burn rate (a larger viewing fire) without an excess of hot air blowing into the room.

An example of when to use the Manual Stove Temperature Mode is if you want to watch a large fire and the room is already up to temperature. The Stove Temperature Mode allows you to have a larger fire and a lower sound level, without the distribution blower.

**NOTE:** During the use of this mode, if you keep increasing the temperature dial setting to increase the fire size, the distribution blower will automatically come on when the ESP Temperature

# MANUAL START UP



Fig. 26

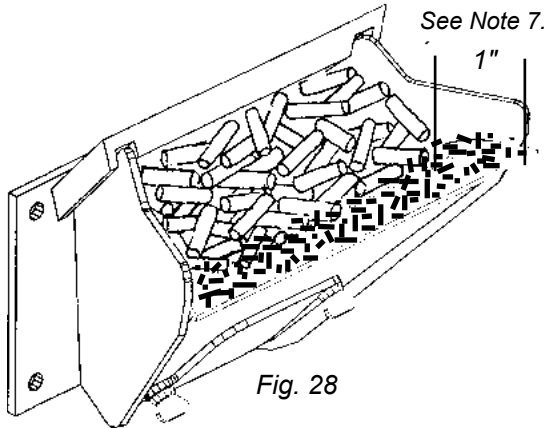
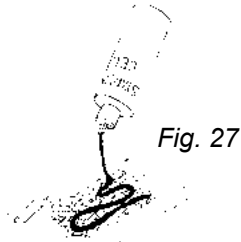

## Helpful Hints

1. Fines are small pieces of broken pellets (sawdust). Fines do not flow easily and often build up on the hopper funnel bottom angles. You can push these fines into the feeder opening and then fill the hopper with pellets. As the system works, they will be burned. Or you can clean them out before filling the hopper. As the system works, they will be burned.
2. The "TEST" cycle will operate the feeder motor for exactly one minute. Turning to "TEST" again and again may purge too much fuel into the burn pot causing excessive smoke on start-up.
3. The firebox low pressure switch will not allow the auger motor or the igniter element to operate if the view door or the ash pan door are open.
4. Adjust Feed Rate. If this is your first fire or you are trying different pellets, set the feed adjuster to #4, Fig. 26. This is a conservative number and will probably need to be increased. After you know a feed rate setting that works well, use that setting. Remember, if your feed rate is too high you may waste fuel.
5. This is usually a weekly maintenance procedure. Cleaning the burn pot with the scraper with a small amount of new fuel in the bottom is not a problem. First, scrape the ashes on the front of the burn pot into the ash pan. Then, scrape the top surface of the burn pot downward into the base of the burn pot. When the stove is ignited these scrapings will be pushed out by the feeder and burned.
6. The ash pan can hold the ashes from approximately 1 ton of premium fuel. This means the ashes will only need to be emptied a few times a year.
7. Setting the feed adjuster # for maximum burn: With the unit burning in "AUTO", turn to "Stove Mode" and put the fan on "H". Set the Temperature Dial to #7. Allow the unit to burn for about 30 minutes and check ash on front of burn pot. Fig. 28. If the ash line is larger than 1", turn the feed adjuster from #3 to #4. Allow another 30 minutes of burn time and check again. If, at #6 setting, a 1" or less ash bed is not obtainable, it is not a problem. The 1" ash bed is only a maximum burn rate and at most normal settings the ash bed will be larger.

## Starting Fire

### Igniter Switch to "MANUAL" (down position)

Make sure the unit is plugged into a 120 VAC, 60 HZ electrical source. The power light should be the only light lit.

1. Turn **FEED ADJUSTER** to desired feed rate. No. 4 is good for most pellets.<sup>4</sup>
2. Turn the **MODE SELECTOR** to "OFF" and then to the desired mode. This will reset control and start the combustion motor.
3. Turn the **TEMPERATURE DIAL** to the desired setting.
4. Clean burn pot with scraper if necessary.<sup>5</sup>
5. Fill burn pot with pellets, only level with front edge. (Do Not Over Fill).
6. Add starting gel on top of the pellets. Stir gel into pellets for fast lighting.
7. Light starting gel with a match, and close the door. Operation will begin when the fire reaches the proper temperature.<sup>3</sup>
8. Fill hopper with pellets and remove ashes as required.<sup>1, 6</sup>

## WARNING

"NEVER USE GASOLINE, GASOLINE-TYPE LANTERN FUEL, KEROSENE, CHARCOAL LIGHTER FLUID, OR SIMILAR LIQUIDS TO START OR "FRESHEN UP " A FIRE IN THIS HEATER. KEEP ALL SUCH LIQUIDS WELL AWAY FROM THE HEATER WHILE IN USE".

## WARNING

ONLY USE WOOD PELLET FUEL. DO NOT BURN GARBAGE IN STOVE.

# AUTOMATIC IGNITION ESP CONTROL

## Dealer Diagnostic Port

For dealer maintenance only. Requires special DDM monitor supplied to Harman Dealers

## Distribution Blower speed adjustment range:

L = low  
H = high

Variable speed anywhere between L and H; although as the stove temp. goes up, so does the low end of the scale.

## Mode Selector

Allows you to choose between Room Temp Mode, Stove Temp Mode, or OFF. Also allows you to vary the distribution blower speed by turning the knob to the high or low side of each mode.

## Igniter switch

Set to appropriate Start-Up mode.

## Test

Runs all motors at full speed for one minute to check operation. After two minutes the stove will go to minimum burn and the blowers will alternate from high to low every minute to remind you that you are still in "Test Mode".

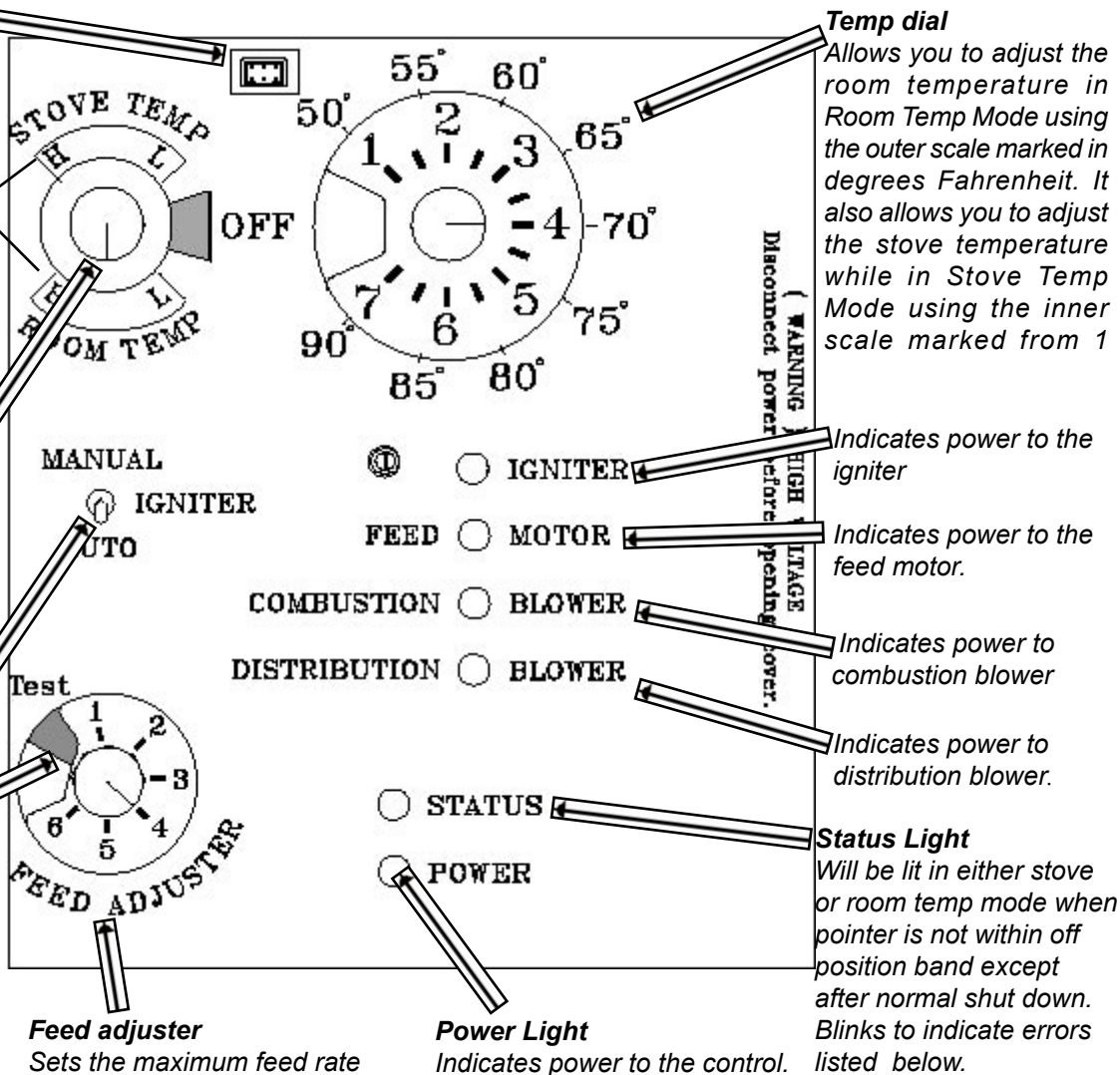

## Temp dial

Allows you to adjust the room temperature in Room Temp Mode using the outer scale marked in degrees Fahrenheit. It also allows you to adjust the stove temperature while in Stove Temp Mode using the inner scale marked from 1

WARNING! HIGH VOLTAGE! Disconnect power before opening cover.

Indicates power to the igniter

Indicates power to the feed motor.

Indicates power to combustion blower

Indicates power to distribution blower.

**Status Light**  
Will be lit in either stove or room temp mode when pointer is not within off position band except after normal shut down. Blinks to indicate errors listed below.

**Power Light**  
Indicates power to the control.

**Feed adjuster**  
Sets the maximum feed rate

## Status light error messages:

**1 Blink:** Indicates control board self diagnostic failure. This requires a manual reset\*.

**3 Blinks:** Indicates ESP (Exhaust Sensing Probe) failure. This requires a manual reset\*.

**4 Blinks:** Can occur only in Room Temp Mode and indicates Room Sensing Probe failed or not installed. If a Room Sensing Probe is then installed, the status light will automatically reset.

**5 Blinks (In Igniter Auto. Mode Only):** Indicates that the unit has failed to light within the 36 minute start cycle. To reset - Turn Mode Selector to "OFF", then turn to either mode again.

**6 Blinks :** Indicates that the control has calculated poor or incomplete combustion occurring for more than 50 minutes.

A six blink status may be set if the stove is allowed to run out of pellets. To reset, turn mode selector to "OFF" then back on to the desired mode. If the unit was not out of pellets, see Troubleshooting section, Page 26, for more details.

\* **Manual reset-** disconnect power cord for a few seconds and reconnect. If error still occurs call your Dealer.

# Low Draft Voltage Adjustment

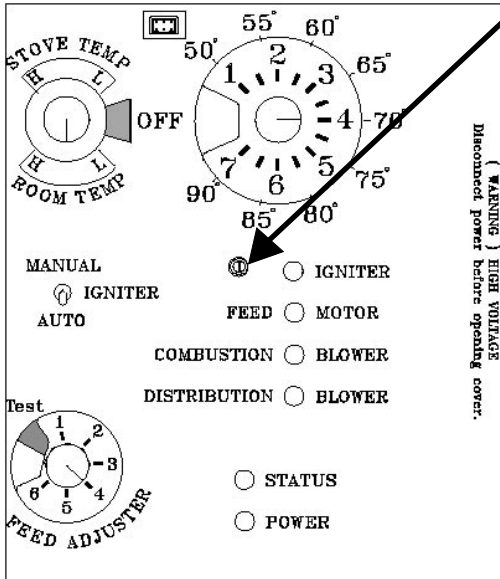

Fig.29

## Low Draft Voltage Adjustment

These units are pre-tested at the factory with exactly 120 Volts A.C., 60 Hz. They are checked and adjusted for firebox tightness, gasket leakage, motor operation and igniter operation. The XXV is then factory set at a mid-point adjustment and in most cases will not need any adjustments. **NOTE: The factory low draft setting may not be correct for the unit's permanent installation conditions.**

The control board on the XXV is equipped with a low draft adjustment port. Located on the control face just to the left of the igniter light. This voltage adjustment is provided to allow the unit to be adjusted for the household voltage where the unit is going to be in permanent operation. **NOTE: The line voltage varies from area to area and often home to home.**

The low draft voltage should be adjusted to achieve the most efficient burn on low burn or "maintenance". This voltage adjustment allows the installer to change the low voltage set point approximately 10 volts. This adjustment should be done by the installer during set up because a draft meter reading is **required** to insure proper set up.

If the unit is not adjusted properly, it does not cause a safety concern. If the unit is adjusted too high, only efficiency is lost. If the unit is adjusted too low, the low draft pressure switch will not allow the feed motor or the igniter to operate.

A simple draft test should be performed after

## Combustion Motor Speed Control

**Low draft only set point.**

The small straight screwdriver slot is plastic; therefore, the unit can be adjusted while in operation.

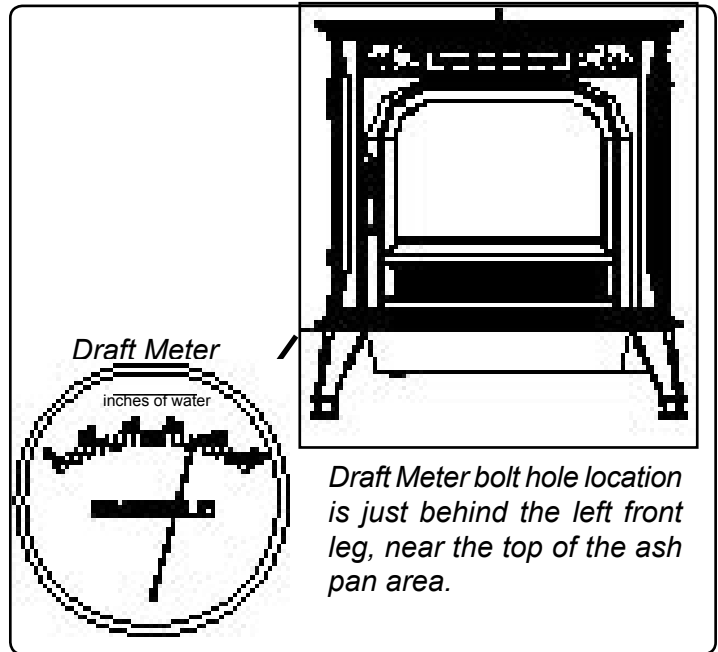

Fig.30

completing the flue pipe installation. To record the results for future reference:

1. Plug unit into a 120VAC, 60 HZ outlet.
2. Close the hopper lid, front view door, and the ash pan. Neither pellets or a fire are required for this test.
3. With the mode selector in the "OFF" position, turn the feed adjuster to "TEST".
4. Record the high draft \_\_\_\_\_ in W.C. (Normal is -.50 to -.60) The control will be on the High Draft for a total of 2 minutes.
5. After 2 minutes, the combustion motor will go down to low draft and the distribution blower will go on high. Allow approximately 15 seconds to pass for the combustion motor to slow before checking the low draft.
6. If the low draft is between -.35 and -.45, record the reading \_\_\_\_\_ in W.C. If the reading is higher, slowly turn the set screw counter-clockwise until the draft lowers. If the reading is lower, very slowly turn the set screw clockwise until the draft increases.

**NOTE: The test mode alternates from high to low draft every 60 seconds. If more time is needed for draft adjustment, wait until the next low draft cycle.**

**NOTE: In some cases, the draft may not go as low as -.35 to -.45 even with the set screw completely counter-clockwise, ideally, you should just set it as low as possible.**

# Room Sensor Installation

## Room Sensor Installation



Fig. 31

The room sensor is a small temperature sensor on the end of a 60" gray wire. This sensor is installed much like a standard wall thermostat. Because it is so small, it can be hidden along the trim of a doorway or even up the leg of a coffee table. There is a remote room sensor port on the rear of the unit for easy external connection. Use standard 18-2 thermostat wire to extend the distance to the desired location (100' maximum). The room sensor should be installed in the location where you want to control the temperature.

In most installations locating the room sensor behind the stove near the distribution fan works well because the sensor monitors the room air being drawn into the distribution fan.

NOTE: Distances of more than 25 feet from the unit or in another room are not recommended. The room sensor is essential for the XXV's excellent efficiency.

NOTE: **It is recommended that the room sensor be installed**, even if only installed on the rear of the unit as a return air sensor.

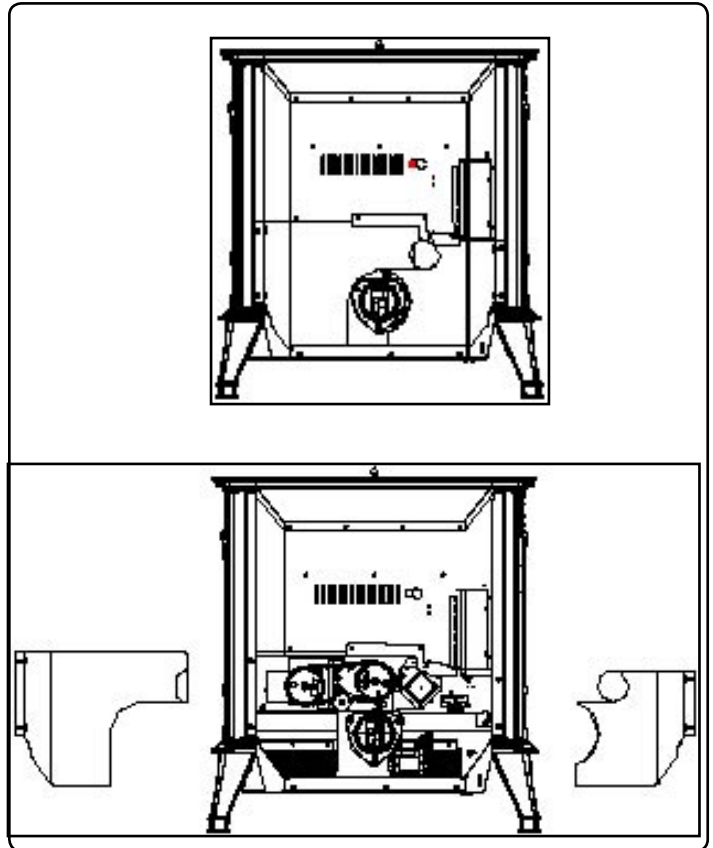

Fig. 32



# Maintenance

## Cleaning the Door Glass

- Always use a soft cloth and glass cleaner (such as Windex, or a mixture of vinegar & water) to clean the glass.
- Do not use razor blades or any other hard object to scrape the glass.

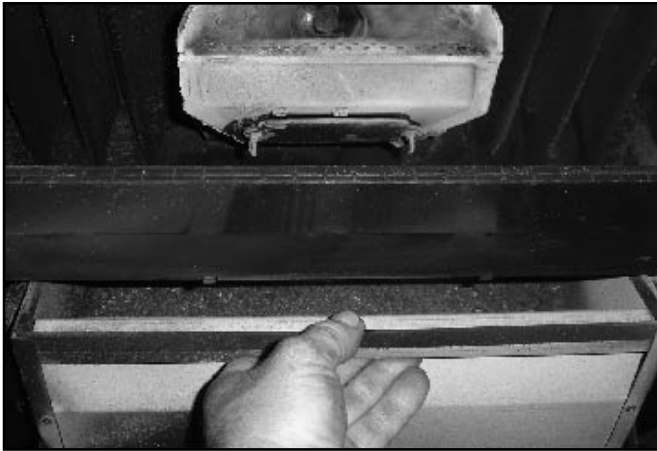

Fig. 33



Fig. 34



Fig. 35

## Removing Ashes:

When approximately 1 ton of pellets has been burned it will be necessary to empty the ash pan.

## Disposal of Ashes

Ashes should be placed in a metal container with a tight fitting lid. The closed container of ashes should be placed on a noncombustible floor or on the ground, well away from all combustible materials, pending final disposal. If ashes are disposed of by burial in soil or otherwise locally dispersed, they should be retained in the closed container until all cinders have thoroughly cooled.

It is recommended that the stove is cold and shut down when removing ash pan.

1. Open front door of stove and then open the ash door by pulling downward on the ash lip. Remove the ash pan (be sure to wear protective gloves if the stove is not cooled down). See Fig. 33.
2. Slide the ash pan back into the stove, seating it against the rear of the firebox. Lift the ash lip to close the ash door and then close the front door of the stove.

## Cleaning:

The stove should be cleaned after burning approximately 1 ton of pellets (50 bags). The cleaner the stove the more efficient it will be. You will burn less pellets and heat output will be greater.

**Note:** Higher ash content pellets will require more frequent cleanings.

1. Shut down stove and **disconnect power cord** to insure that all motors are stopped.
2. Clean heat exchanger with scraper as shown in fig 34.
3. Brush or scrape the inside of the stove to remove fly ash.
4. Scrape burnpot with flat end of scraper provided with the stove. Inspect the holes on the burnpot surface. See Fig. 35.
5. Open burn pot clean-out. Clean fly ash from burn pot and replace cover. See Figures 39 and 40 on page 24.
6. Remove ash pan and dispose of ashes in an ap-



# Maintenance

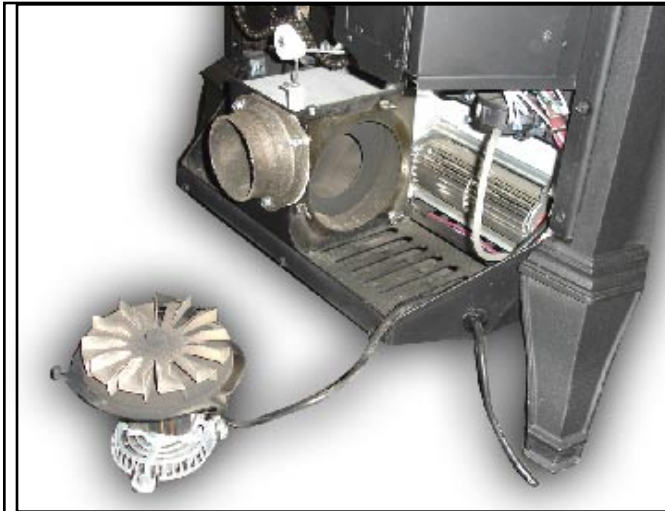

Fig. 36

*Brush not supplied. Can be found in hardware stores.*

Fig. 37

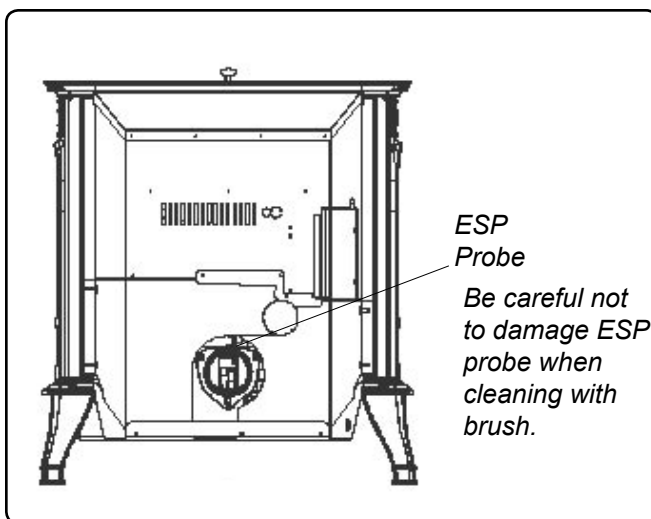

Fig. 38

*ESP Probe  
Be careful not to damage ESP probe when cleaning with brush.*

proved manner, according to local codes.

7. Remove combustion blower by loosening the 3 wingnuts, twisting the combustion blower mount plate counterclockwise to unlock, and pulling the blower out.
8. Clean the combustion blower wheel with a brush and a vacuum cleaner. Note: Do not use a household vacuum to clean the stove. We recommend that you use a shop vacuum that is equipped with a fine dust filter called a HEPA filter or a vacuum specially made for fly ash and soot. USING A VACUUM WHICH IS NOT EQUIPPED WITH A FINE DUST FILTER WILL BLOW FLY ASH AND SOOT OUT INTO THE ROOM.

**NOTE: THE STOVE MUST BE COMPLETELY OUT BEFORE YOU VACUUM THE STOVE. LIVE PELLETS, IF SUCKED INTO THE VACUUM WILL LIGHT THE VACUUM ON FIRE AND MAY ULTIMATELY CAUSE A HOUSE FIRE.**

9. Use a brush to clean the flue, being careful not to damage the ESP probe.
10. Reinstall the blower by turning plate clockwise to lock into place and tightening the 3 wingnuts. Be sure the fan plate is flush with the exhaust housing on stove body and motor armature points up toward the hopper.
11. Slide ash pan into stove and latch the door.

## Soot and Fly Ash

**Formation and Need for Removal** - The products of combustion will contain small particles of flyash. The flyash will collect in the exhaust venting system and restrict the flow of the fuel gases. Incomplete combustion, such as occurs during startup, shutdown, or incorrect operation of the room heater will lead to some soot formation which will collect in the exhaust venting system. The exhaust venting system should be inspected at least once every year to determine if cleaning is necessary.

The products of combustion will contain small particles of fly ash which must be removed from the inner walls of the stove and from the venting system periodically. Removing fly ash and soot improves efficiency, insures that the flue venting passageway is clear and unobstructed. The stove should be cleaned after each ton of pellets (50 bags) and the venting system inspected and cleaned after each heating season.

# Maintenance - Burn Pot



Fig. 39



Fig. 40

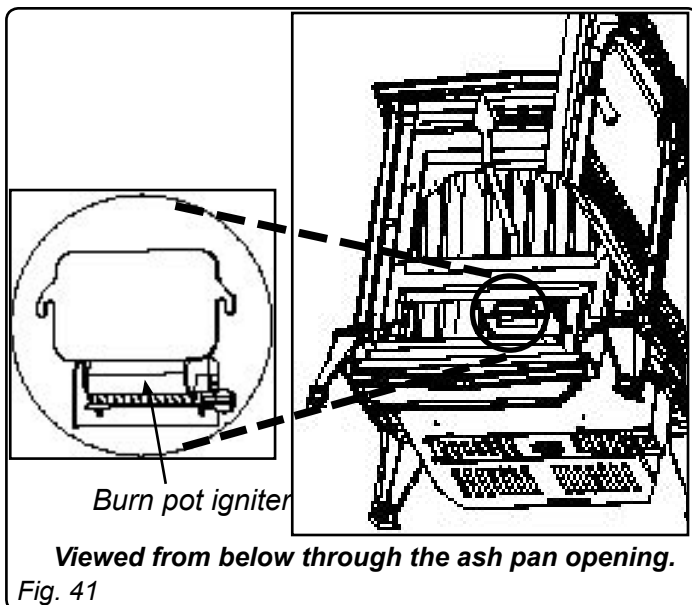

Fig. 41

## **Burn Pot Cleaning and Maintenance**

1. Scrape the top holed surface and sides of the burn pot.(Fig 39) It is not necessary to completely remove all loose material from the burn pot. The excess will be pushed out during the next use.

### ***DANGER***

***Disconnect the power to the unit before removing cover.***

2. Loosen the (2) wing thumb screws on the lower front angle of the burn pot. (Fig. 39)

3. Lift off the clean-out cover (Fig.40) to open the bottom clean-out chamber. (Fig.41)

4. Clean ash buildup from inside the chamber while cover is off. Use the scraper to tap on the top front edge of the burn pot. This will help knock pieces of ash, loosened by the scraping process, down through the holes. It also helps knock scale off of the igniter element.

### **Figure 41**

The igniter is made to be removable for service by insulated male/female wire connectors. These connections between the hot leads (the wires inside the burn pot) and the cold leads (the wires from the control board) are always pulled to the inside rear of the feeder body. **(Not coiled inside the burn pot.)**

It is very important that these connections are to the inside rear of the feeder body. Also, the extra wire of the igniter wire service loop must be pulled out through the rear of the feeder and tied up so that it will not be damaged by any moving parts.

**Note: The hot lead/cold lead connection must always be pulled to the rear of the feeder body before operation.**

### ***WARNING***

**Use caution when cleaning burn pot clean-out chamber. Do not damage the high temperature igniter wires.**

## Maintenance - Cleaning the Feeder Body

Pellet fines will accumulate in the feeder body over a period of time; therefore, a yearly inspection and cleaning of this must be performed.

To clean out fines:

1. Remove right rear cover panel ( see rear cover installation on page 4).
2. Remove wing nut and feeder cover on the right side of the feeder. See Fig. 43.
3. Use a vacuum cleaner to remove all fines.
4. Reinstall feed cover, wing nut, and right rear cover panel.

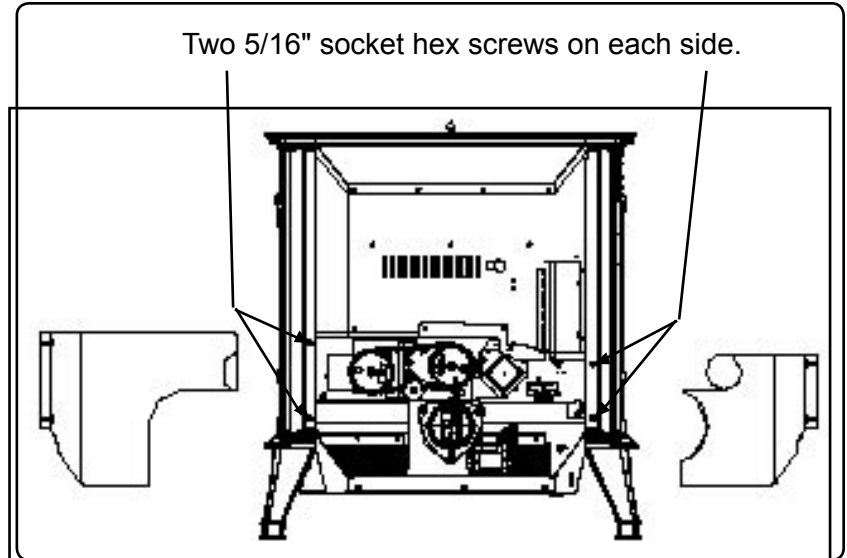

Fig. 42

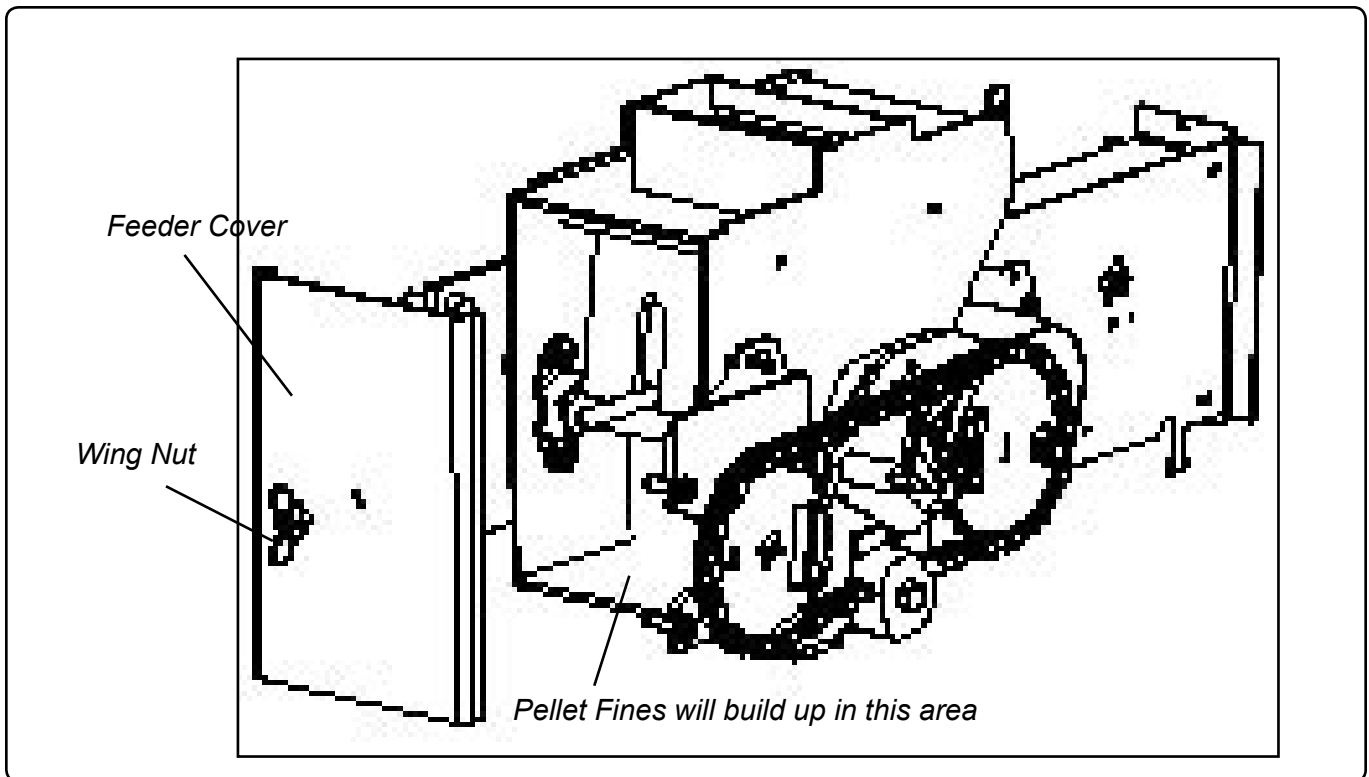

Fig. 43

# Trouble-Shooting

## FEEDER DOES NOT FEED

1. No pellets in hopper.
2. Firebox draft may be too low for low draft pressure switch in feeder circuit to operate. **Check for closed doors**, loose or missing gasket on doors or hopper lid, or a faulty pressure switch.
3. Feed motor will not run until ESP

senses 165 deg. F. Maybe you did not put enough pellets in the burn pot before lighting the fire manually.

4. Something is restricting flow in the hopper or causing the slide plate to stick.
5. Feed motor has failed.

## PARTIALLY BURNED PELLETS

1. Feed rate too high.
2. Draft too low. (Check burn pot clean-out slide and door gasket).
3. Burn pot or heat exchanger tubes may need to be cleaned.
4. Combination of all the above.
5. #6 status blink: A 6 blink control board status indication is caused by poor or incomplete combustion. The Automatic Ignition circuit board has the ability to track the combustion through feed settings and ESP temperatures. When the control board has calculated poor or incomplete combustion, it will shut down the unit as a safety feature. (Poor or incomplete combustion is a contributor of creosote which may cause a chimney fire)

A 6 blink status may be caused by several things:

1. Blocked or partially blocked flue.
2. Blocked or partially blocked inlet air.
  - a. Backdraft damper on the inlet pipe may be stuck closed.
  - b. If outside air is installed, the inlet cover may be blocked.
3. The air chamber under the burnpot may be filled with fines and small bits of ash.
4. The holes in the burnpot may be getting filled with ash or carbon buildup.
5. Combustion blower fan blades may need cleaned.
6. There is no fuel in the hopper.

## SMOKE SMELL

Seal the vent pipe joints and connection to stove with silicone.

## FIRE HAS GONE OUT

1. No pellets in hopper.
2. Draft setting is too low.
3. Something is restricting fuel flow.
4. Feed motor or combustion blower has failed.
5. Power failure or blown fuse.

## SMOKE IS VISIBLE COMING OUT OF VENT

1. Air-fuel ratio is too rich.

A. Feed rate too high.

- B. Draft too low caused by a gasket leak.

## LOW HEAT OUTPUT

1. Feed rate too low
2. Draft too low because of gasket leak.
3. Poor quality or damp pellets
4. Combination of all the above

## Helpful Hints

### Cleaning Burn Pot

Whenever your stove is not burning, take the opportunity to scrape the burn pot to remove carbon buildup. A vacuum cleaner is handy to remove the residue. **Be sure the stove is cold if you use a vacuum.**

Carbon buildup can be scraped loose with the fire burning using the special tool provided with your stove. Scrape the floor and sides of the burn pot. The carbon will be pushed out by the incoming fuel. Always wear gloves to do this.

### Removing Ashes

Turn the Temp Dial to number 1 approximately 30 minutes before removing ashes. This will result in a cooler stove and ash pan.

Maximum Feed Adjuster settings are not needed in most cases. Operating in the normal range (#4) is recommended when maximum heat output is not required. The ESP probe prevents the stove from being over-fired.

Keep the stove free of dust and dirt.

## Fuel

Wood Pellet size is regulated at .23" to .35" in diameter with a maximum length of 1.5" long.

Pellet fuels are put into 3 categories in terms of ash content. Premium at 1% or less, Standard at 3% or less and all others at 3% or more.

The XXV is capable of burning all 3 categories of pellets due to a patented feeder and burn pot system.

It should be noted, however, that higher ash content will require more frequent ash removal, scraping of the burn pot, increased cleaning frequency and may provide less BTU's per pound. Normally, standard and high ash pellets cost less than premium pellets and can be cost effective when burned in the XXV.

The moisture content must not exceed 8%. Higher moisture will rob BTU's and may not burn properly.

Pellet fuel should **not** be stored within the stove installation clearances or within the space required for charging and ash removal. See Page 5.

# XXV Feeder and Specifications

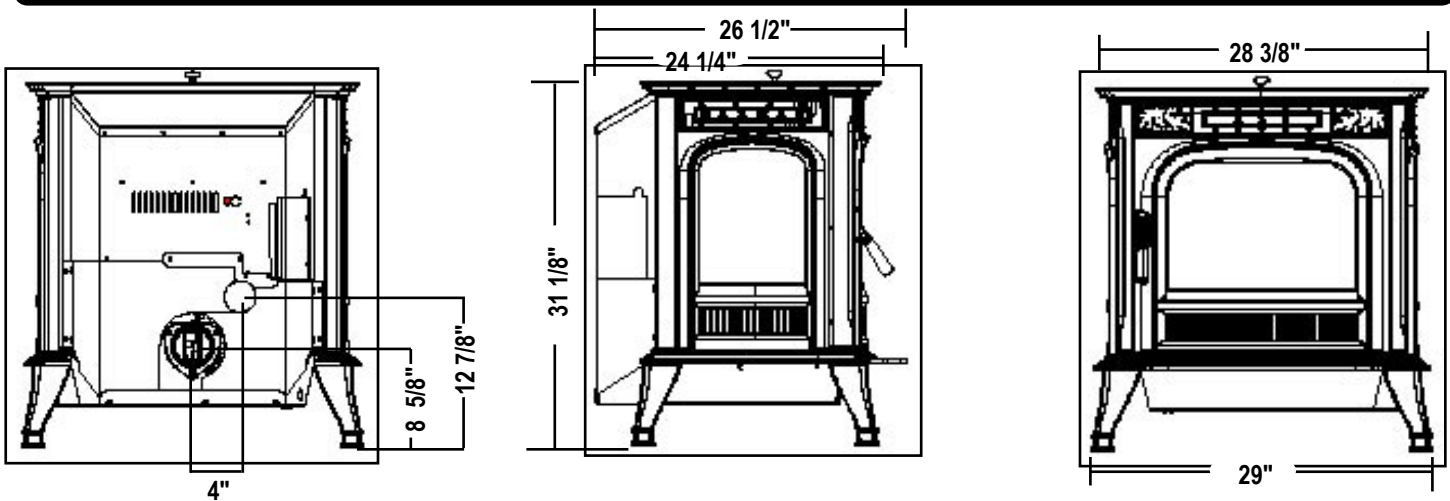
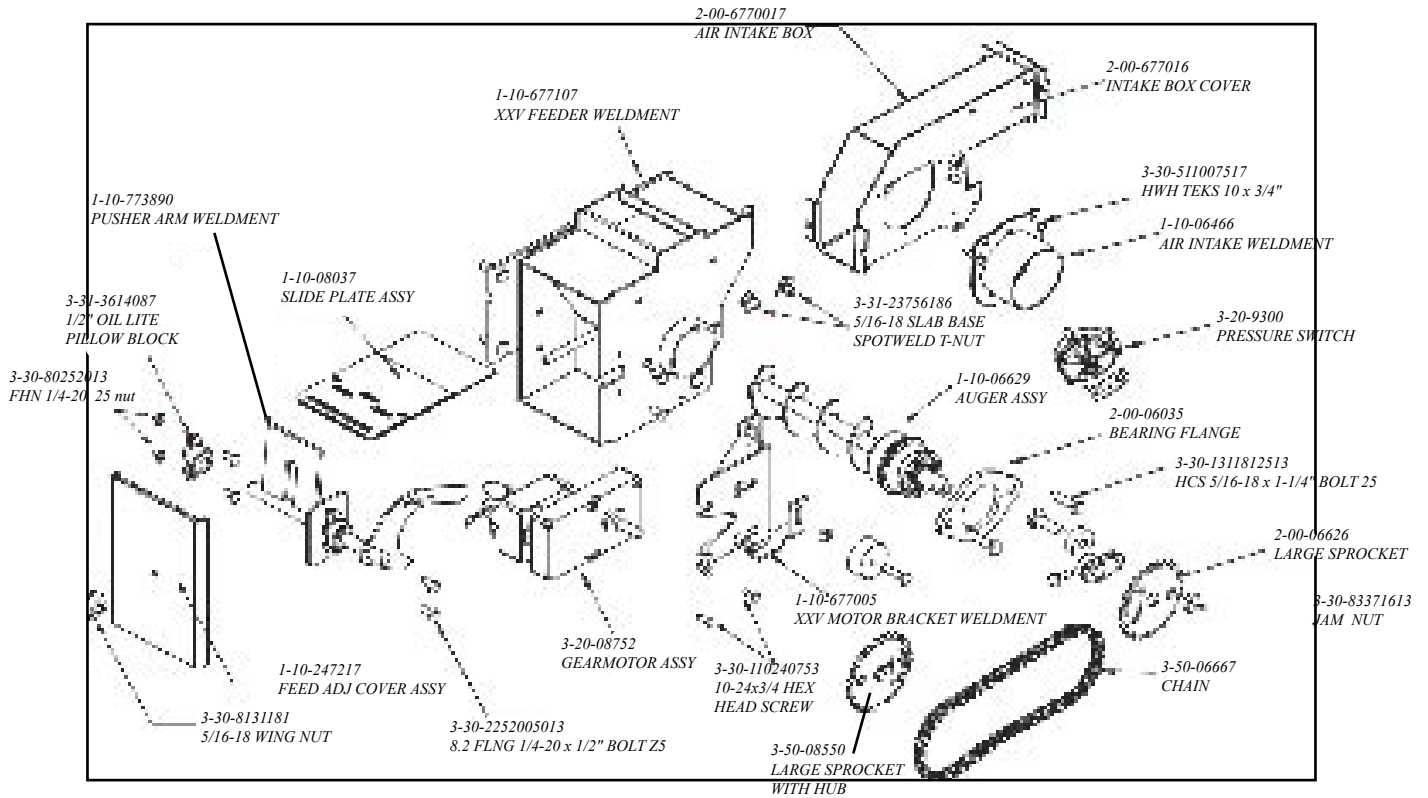

**Weight**  
**Blower**  
**Feed Rate**  
**Hopper Capacity**  
**Fuel**  
**Flue Size**  
**Outside Air Size**  
**Fuse Rating**

**375 lbs.**  
**150 cfm**  
**approx. 1lb. to 5.75 lbs/hr.**  
**65 lbs**  
**Wood Pellets**  
**3 inch or optional 6" top exit**  
**2 3/8" I.D. inch**  
**6 amp**

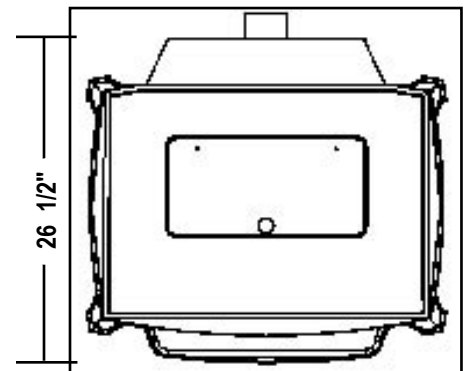

# Options

## Floor Protector

The Steel Floor Protector measures 32 inches wide by 32 inches deep. This is the minimum size for floor protection with this unit. It is made of 20 gauge steel.

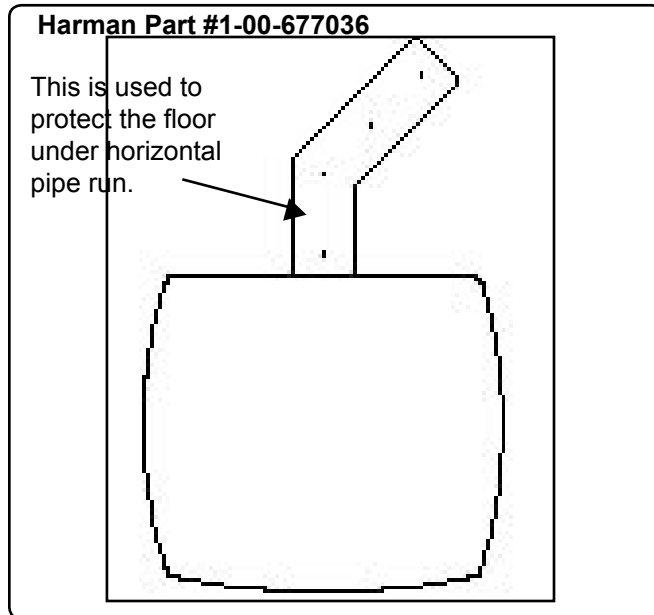

## Direct Vent Wall Passthrough

The Harman Direct Vent Wall Passthrough makes installing your Harman Pellet Stove with outside air a lot easier. It is made to fit walls from 4 1/2" up to 10 1/8" thick with a square opening of

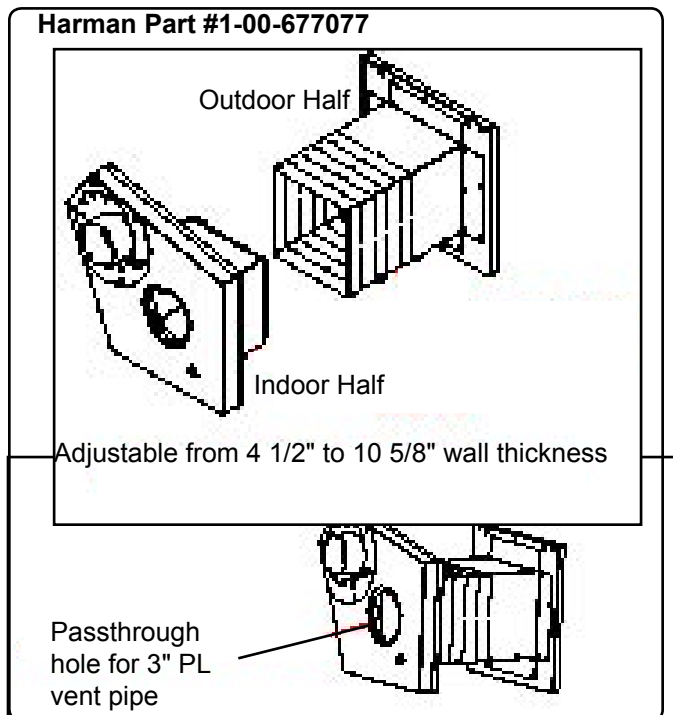

## XXV Top Flue Option

The Top Flue option attaches to the exhaust on the rear of the stove, and extends it to the top with a six inch stub.

This gives the appearance of a wood stove and also allows venting with existing single wall, connector. A 12 inch piece of 4" PL vent is included to act as an insulator.







# XXV Parts List

<u>Description</u>	<u>Part Number</u>
Hopper Gasket(6 ft.)	3-44-375501
Ash Pan Assembly	1-10-677044
Burn Pot Weldment	1-10-00675
Right Rear Shield	1-10-677085
Left Rear Shield	1-10-677084
Arrow Scraper	2-00-773850
Flame Guide	3-00-03000
Wiring Harness Assembly	3-20-08727
Thermister Probe	3-20-00744
Room Sensor	3-20-00906
Circuit Board	3-20-05374
Differential Switch	3-20-9301
5" Double Fan Blade	3-20-502221
Combustion Blower	3-21-08639
Distribution Blower	3-20-29045A
Hopper Lid Latch	2-00-06697
Hopper Lid Knob	3-43-02000-8
Hopper Lid Glass	3-40-247100
Hopper Lid Screws	3-31-129004
Hopper Lid Gasket (4 ft)	3-44-375501
Wood Handle	3-40-00123
Ash Door Gasket (3 ft)	3-44-00539
Glass Gasket (5 ft)	3-44-1186258229
Load Door Gasket (6 ft)	3-44-53716
Wall Plunger	3-31-5500
Rocker Switch	3-20-07625
Power Cord	3-20-29685
White/Black Control Knob(3)	3-31-605
Control Knob Shaft(3)	3-31-015
Mirrored Front Glass	3-40-677000
Burn Pot Gasket(1)	3-44-00409
Tailpipe Gasket	3-44-06179
Wiring Diagram	3-90-00677
Control Panel Sticker	3-90-247155A
Owner's Manual	3-90-00684
Hopper Hinge Label	3-90-09416
Igniter Assembly	1-10-06620
Cleanout Cover(1)	2-00-06623
1/4-20 x 1/2" Wing Screw w/Collar(2)	3-31-782108
Top Vent Option	1-00-677120
<u>Options:</u> Direct Vent Wall Passthrough	1-00-677077
25' Flex Pipe	1-00-08543
Battery Back Up	3-20-502
Surge Support	3-20-503
Floor Protector	1-00-677036

**HARMAN GOLD WARRANTY**  
**6 YEAR TRANSFERABLE LIMITED**  
**WARRANTY (Residential)**  
**1 YEAR LIMITED WARRANTY (Commercial)**



Harman Stove Company warrants its products to be free from defects in material or workmanship, in normal use and service, for a period of 6 years from the date of sales invoice and for mechanical and electrical failures, in normal use and service, for a period of 3 years from the date of sales invoice.

If defective in material or workmanship, during the warranty period, Harman Stove Company will, at its option, repair or replace the product as described below.

The warranty above constitutes the entire warranty with respect to Harman Stove Company products. HARMAN STOVE COMPANY MAKES NO OTHER WARRANTY, EXPRESSED OR IMPLIED, INCLUDING "ANY" WARRANTY OF MERCHANTABILITY, OR WARRANTY OF FITNESS FOR A PARTICULAR PURPOSE. No employee, agent, dealer, or other person is authorized to give any warranty on behalf of Harman Stove Company. This warranty does not apply if the product has been altered in any way after leaving the factory. Harman Stove Company and its agents assume no liability for "resultant damages of any kind" arising from the use of its products. In addition, the manufacturer and its warranty administrator shall be held free and harmless from liability from damage to property related to the operation, proper or improper, of the equipment.

THERE ARE NO WARRANTIES WHICH EXTEND BEYOND THE DESCRIPTION ON THE FACE HEREOF.

THESE WARRANTIES APPLY only if the device is installed and operated as recommended in the user's manual.

THESE WARRANTIES WILL NOT APPLY if abuse, accident, improper installation, negligence, or use beyond rated capacity causes damage.

HOW TO MAKE A CLAIM - Any claim under this warranty should be made to the dealer from whom this appliance was purchased. Then contact is made with manufacturer, giving the model and serial numbers, the date of purchase, your dealer's name and address, plus a simple explanation of the nature of the defect. Extra costs such as mileage and overtime are not covered. Nuisance calls are not covered by these warranties.

THIS WARRANTY IS LIMITED TO DEFECTIVE PARTS - REPAIR AND/OR REPLACEMENT AT HARMAN STOVE COMPANY'S OPTION AND EXCLUDES ANY INCIDENTAL AND CONSEQUENTIAL DAMAGES CONNECTED THEREWITH.

WARRANTY EXCLUSIONS: Failure due, but not limited to, fire, lightning, acts of God, power failures and/or surges, rust, corrosion and venting problems are not covered. Damage and/or repairs including but not limited to; remote controls, filters, fuses, knobs, glass, ceramic brick panels, ceramic fiber afterburners, door packing, tile, ceramic log sets, paint, batteries or battery back-up and related duct work are not covered. Also excluded from this warranty are consumable or normal wear items including but not limited to; flame guides, grates, coal bars, afterburner hoods, fire brick, gaskets. Additional exclusions for corn stoves are burnpot housing weldment, burnpot grate weldment (pellet or corn), burnpot front plate (pellet or corn), burnpot front plate lock, corn auger extension, ceramic insert, and ceramic insert plate. Additional or unusual utility bills incurred due to any malfunction or defect in equipment and the labor cost of gaining access to or removal of a unit that requires special tools or equipment are not covered. Maintenance needed to keep the stove in "good operating condition" is not covered. This includes, but is not limited to, cleaning, adjustment of customer controls and customer education. Labor, materials, expenses and/or equipment needed to comply with law and/or regulations set forth by any governmental agencies are not covered.

This Warranty provides specific legal rights and the consumer may have other rights that vary from state to state.

In the event of change in ownership, the remaining portion of this warranty may be transferred to the new owner by sending the new owner information and a transfer fee of \$25.00 US to the Harman Stove Company.

PLEASE READ THE LITERATURE BY THE MANUFACTURER FOR THE VARIOUS ACCESSORY DEVICES. THE MANUFACTURER WARRANTS THESE ACCESSORY DEVICES, NOT HARMAN STOVE COMPANY OR THEIR WARRANTY ADMINISTRATOR. FURTHERMORE, THESE ACCESSORY DEVICES MUST BE INSTALLED AND USED ACCORDING TO THE RECOMMENDATIONS OF THE MANUFACTURER.

REMEDIES - The remedies set forth herein are exclusive and the liability of seller with respect to any contract or sale or anything done in connection therewith, whether in Contract, in tort, under any warranty, or otherwise, shall not, except as herein expressly provided, exceed the price of the equipment or part of which such liability is based.

CLARIFY - The above represents the complete warranty, which is given in connection with stoves, manufactured by Harman Stove Company. No other commitments, verbal or otherwise, shall apply except by a written addendum to this warranty.