

BACnet Protocol Installation and User's Manual



SmartVFD HVAC

Variable Frequency Drives
for Constant and Variable
Torque Applications

By using this Honeywell literature, you agree that Honeywell will have no liability for any damages arising out of your use or modification to, the literature. You will defend and indemnify Honeywell, its affiliates and subsidiaries, from and against any liability, cost, or damages, including attorneys' fees, arising out of, or resulting from, any modification to the literature by you.

INDEX

Document: DPD00267A
Version release date: 12.11.09

1. Safety	2
1.1 Danger	2
1.2 Warnings	3
1.3 Grounding and ground fault protection	3
2. BACnet - general info	6
3. BACnet technical data	8
3.1 BACnet MS/TP protocol	8
3.2 BACnet IP protocol	8
4. BACnet installation	10
4.1 Prepare for use through ethernet	11
4.2 Prepare for use through MS/TP	13
5. Programming	16
5.1 BACnet MS/TP parameters and monitoring values (M5.7.3)	16
5.2 BACnet IP parameters and monitoring values	18
5.2.1 Ethernet common settings (M5.8.1)	18
5.2.2 BACnet IP settings	18
5.3 BACnet MS/TP parameter descriptions	19
5.3.1 BACnet MS/TP Parameters	19
5.3.2 BACnet MS/TP monitoring values	20
5.4 BACnet IP parameter descriptions	21
5.4.1 Ethernet common settings	21
5.4.2 BACnet IP settings	22
5.4.3 IP monitoring values	22
6. Communications	24
6.1 Object types and properties supported	24
6.1.1 Binary Value Object	25
6.1.2 Analog Value Object	27
6.2 Control word bits	29
6.3 Status word bits	29
7. Fault tracing	30
7.1 Typical fault conditions	30
7.2 Other fault conditions	31
8. Quick setup	34
9. Annex - Protocol implementation conformance statement	36

1. Safety

This manual contains clearly marked cautions and warnings which are intended for your personal safety and to avoid any unintentional damage to the product or connected appliances.

Please read the information included in cautions and warnings carefully.

The cautions and warnings are marked as follows:







	= DANGER! Dangerous voltage
	= WARNING or CAUTION
	= Caution! Hot surface

Table 1. Warning signs

1.1 Danger

- 

The **components of the power unit of the Smart VFD are live** when the VFD is connected to mains potential. Coming into contact with this voltage is **extremely dangerous** and may cause death or severe injury.
- 

The **motor terminals U, V, W and the brake resistor terminals are live** when the drive is connected to mains, even if the motor is not running.
- 

After disconnecting the VFD from the mains, **wait** until the indicators on the keypad go out (if no keypad is attached see the indicators on the cover). Wait 5 more minutes before doing any work on the connections of the drive. Do not open the cover before this time has expired. After expiration of this time, use a measuring equipment to absolutely ensure that no voltage is present. **Always ensure absence of voltage before starting any electrical work!**
- 

The control I/O-terminals are isolated from the mains potential. However, the **relay outputs and other I/O-terminals may have a dangerous control voltage** present even when the drive is disconnected from mains.
- 

Before connecting the VFD to mains make sure that the front and cable covers of the drive are closed.
- 

During a ramp stop (see the Application Manual), the motor is still generating voltage to the drive. Therefore, do not touch the components of the VFD before the motor has completely stopped. Wait until the indicators on the keypad go out (if no keypad is attached see the indicators on the cover). Wait additional 5 minutes before starting any work on the drive.

1.2 Warnings



The Honeywell Smart VFD is meant for **fixed installations only**.



Do not perform any measurements when the VFD is connected to the mains.



The **ground leakage current** of the Honeywell Smart VFD exceeds 3.5mA AC. According to standard EN61800-5-1, a **reinforced protective ground connection** must be ensured. See chapter 1.3.



If the VFD is used as a part of a machine, the **machine manufacturer is responsible** for providing the machine with a **supply disconnecting device** (EN 60204-1).



Only **spare parts** delivered by Honeywell can be used.



At power-up, power brake or fault reset **the motor will start immediately** if the start signal is active, unless the pulse control for Start/Stop logic has been selected. Furthermore, the I/O functionalities (including start inputs) may change if parameters, applications or software are changed. Disconnect, therefore, the motor if an unexpected start can cause danger.



The **motor starts automatically** after automatic fault reset if the auto restart function is activated. See the Application Manual for more detailed information.



Prior to measurements on the motor or the motor cable, disconnect the motor cable from the VFD.



Do not touch the components on the circuit boards. Static voltage discharge may damage the components.



Check that the **EMC level** of the VFD corresponds to the requirements of your supply network.

1.3 Grounding and ground fault protection



CAUTION!

The Honeywell Smart VFD must always be grounded with a ground conductor to the ground terminal marked with .

The earth leakage current of the drive exceeds 3.5mA AC. According to EN61800-5-1, one or more of the following conditions for the associated protective circuit shall be satisfied:

- a) The protective conductor shall have a cross-sectional area of at least 10 mm² Cu or 16 mm² Al, through its total run.
- b) Where the protective conductor has a cross-sectional area of less than 10 mm² Cu or 16 mm² Al, a second protective conductor of at least the same cross-sectional area shall be provided up to a point where the protective conductor has a cross-sectional area not less than 10 mm² Cu or 16 mm² Al.
- c) Automatic disconnection of the supply in case of loss of continuity of the protective conductor.

The cross-sectional area of every protective grounding conductor which does not form part of the supply cable or cable enclosure shall, in any case, be not less than:

- 2.5mm² if mechanical protection is provided or
- 4mm² if mechanical protection is not provided.

The ground fault protection inside the VFD protects only the drive itself against earth faults in the motor or the motor cable. It is not intended for personal safety.

Due to the high capacitive currents present in the VFD, fault current protective switches may not function properly.



Do not perform any voltage withstand tests on any part of the drive. There is a certain procedure according to which the tests shall be performed. Ignoring this procedure may result in damaged product.

2. BACnet - general info

BACnet stands for 'Building Automation and Control Networks'. It is the common name for the communication standard ISO 16484-5 which defines the methods and the protocol for cooperating building automation devices to communicate. Devices can be designed to operate using BACnet communication protocol as well as utilising BACnet protocol to communicate between systems. BACnet is an internationally accepted protocol for building automation (e.g. lighting control, air conditioning and heating automation) and control over a communications network.

BACnet provides a method by which computer-based control equipment, from different manufacturers can work together, or 'interoperate'. For this to be achieved, components must be able to exchange and understand BACnet data messages.

Your Honeywell Smart VFD is equipped with BACnet support as standard.

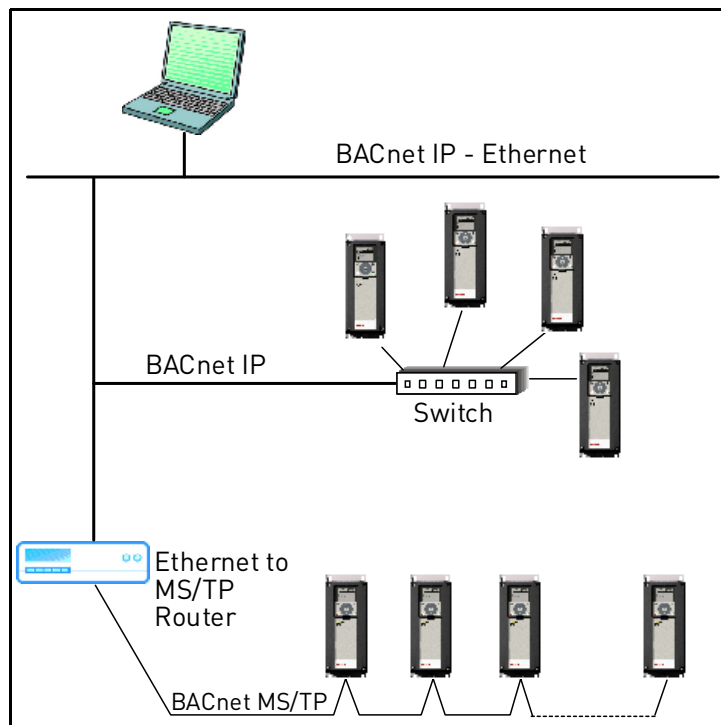

Figure 1. Principal example diagram of BACnet

3. BACnet technical data

3.1 BACnet MS/TP protocol

Connections and communications	Interface	RS-485
	Data transfer method	RS-485 MS/TP, half-duplex
	Transfer cable	STP (Shielded Twisted Pair), type Belden 9841 or similar
	Connector	2.5 mm ²
	Electrical isolation	Functional
	BACnet MS/TP	As described in ANSI/ASHRAE Standards 135-2004
	Baud rate	9600, 19200, 38400 and 76800 baud(supports autobaud detection)

Table 2.

3.2 BACnet IP protocol

Connections and communications	Interface	100Base TX, IEEE 802.3 compatible
	Data transfer method	Ethernet half/full -duplex
	Data transfer speed	10/100 MBit/s, autosensing
	Protocol	BACnet over UDP/IP
	Connector	Shielded RJ45 connector
	Cable type	CAT5e STP
	BACnet IP	As described in ANSI/ASHRAE Standards 135-2004
	Default IP	Selectable: Fixed or DHCP

Table 3.

4. BACnet installation

1

Open the cover of the VFD.



The relay outputs and other I/O-terminals may have a dangerous control voltage present even when the drive is disconnected from mains.

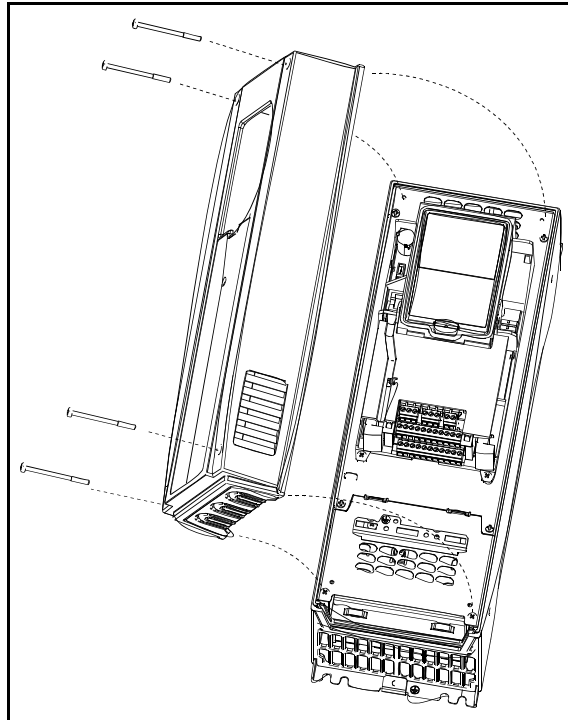

Figure 2.

2

Locate the components that you will need on the VFD to connect and run the BACnet cables.



Be sure not to plug the Ethernet/BACnet IP cable to the terminal under the keypad! This might harm your personal computer.

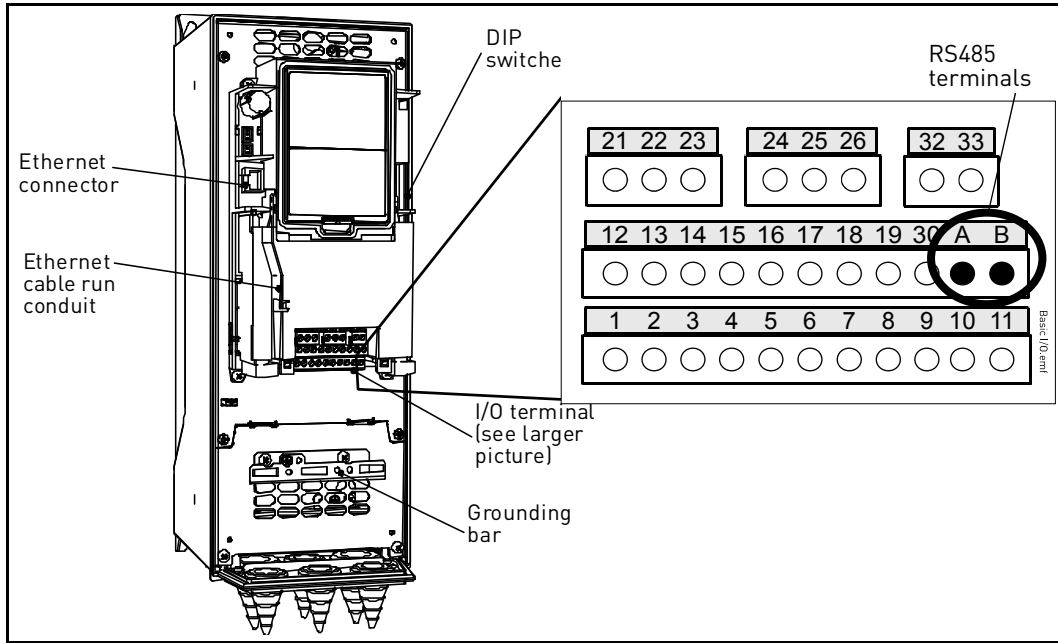

Figure 3.

You can use the BACnet communication protocol through Ethernet and RS485.

4.1 Prepare for use through ethernet

- 3** Connect the Ethernet cable (see specification on page 8) to its terminal and run the cable through the conduit as shown in Figure 4.

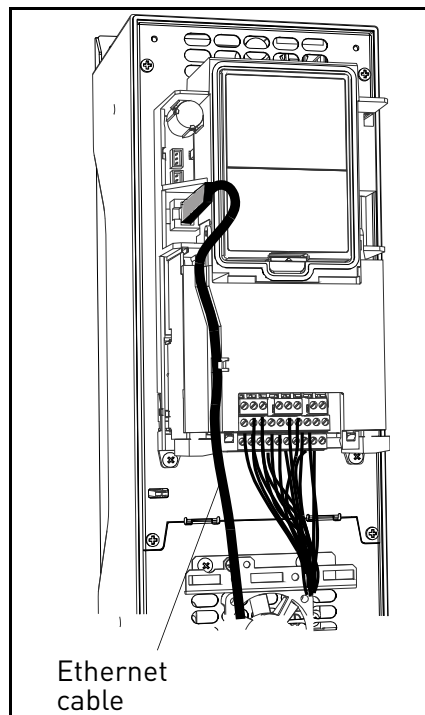

Figure 4.

4 Cut the VFD cover opening for the Ethernet cable (NEMA 1 enclosure).

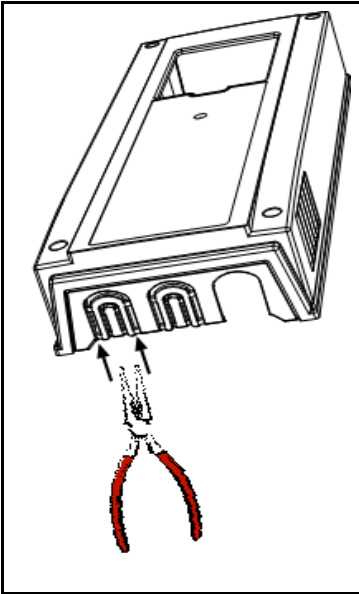

Figure 5.

5 Remount the VFD cover. **NOTE:** When planning the cable runs, remember to keep the distance between the Ethernet cable and the motor cable at a **minimum of 30 cm**.

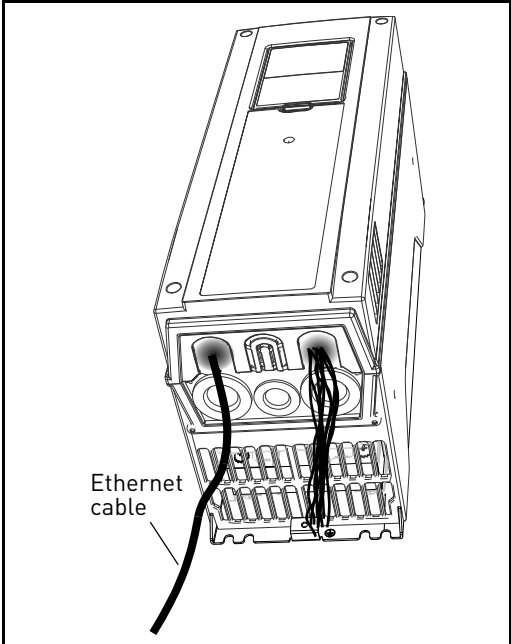
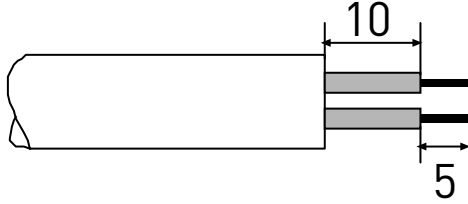

Figure 6.

4.2 Prepare for use through MS/TP

3 Strip about 15 mm of the RS485 cable (see specification on page 8) and cut off the grey cable shield. Remember to do this for both bus cables (except for the last device).
 Leave no more than 10 mm of the cable outside the terminal block and strip the cables at about 5 mm to fit in the terminals. See picture below.



Also strip the cable now at such a distance from the terminal that you can fix it to the frame with the grounding clamp. Strip the cable at a maximum length of 15 mm. **Do not strip the aluminum cable shield!**

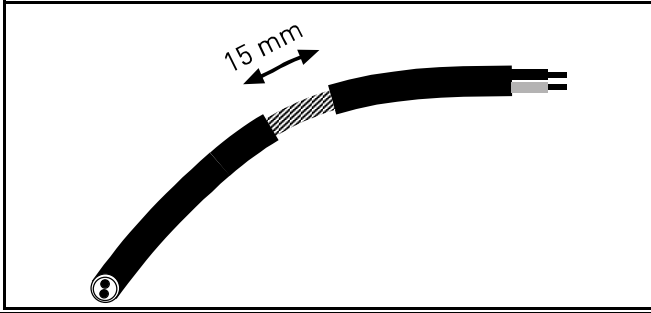

4 Then connect the cable to its appropriate terminals on Honeywell Smart VFD standard terminal block, terminals **A** and **B** (A = negative, B = positive). See Figure 7.

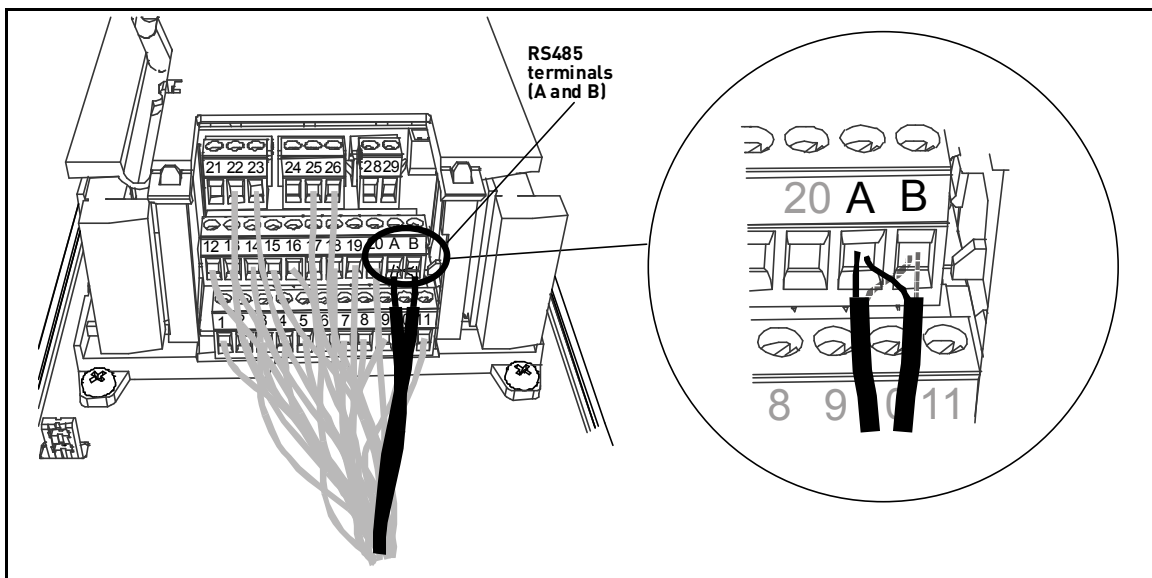
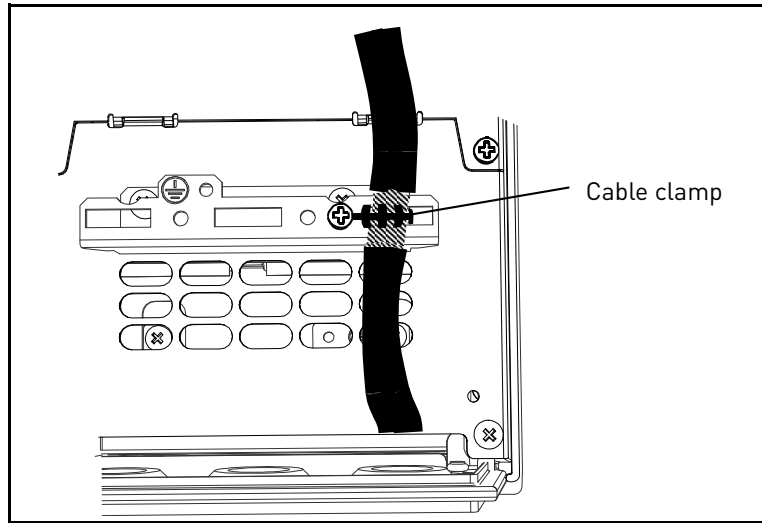

Figure 7.

5

Using the cable clamp included in the delivery of the drive, ground the shield of the RS485 cable to the frame of the VFD.



6

If the drive is the last device on the bus, the bus termination must be set. Locate the DIP switches to the right of the control keypad of the drive and turn the switch for the RS485 bus termination resistor to position ON. Biasing is built in the termination resistor. See also step 9 on page 15.

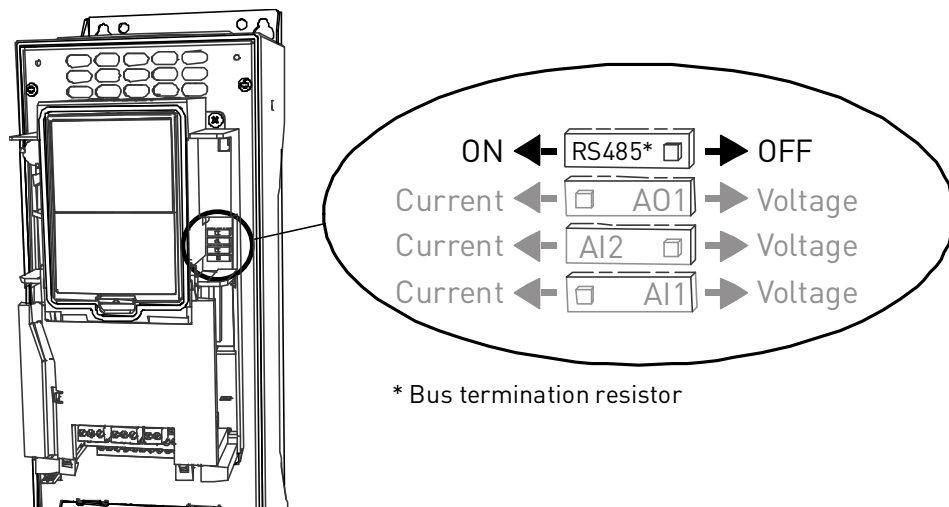

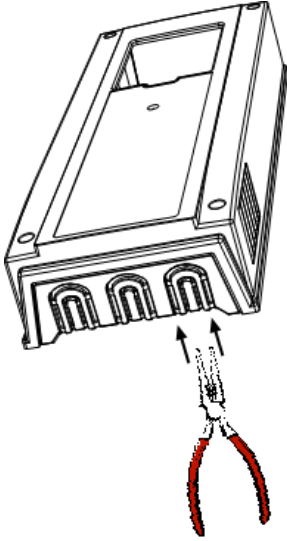
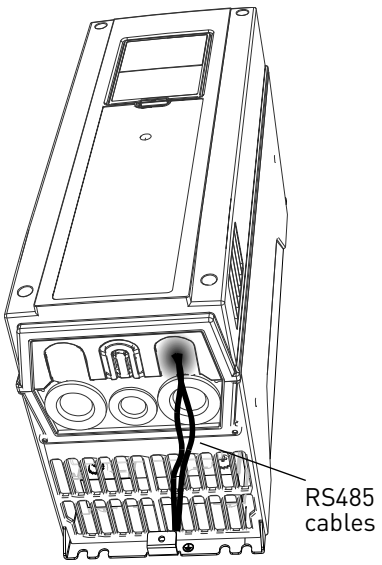
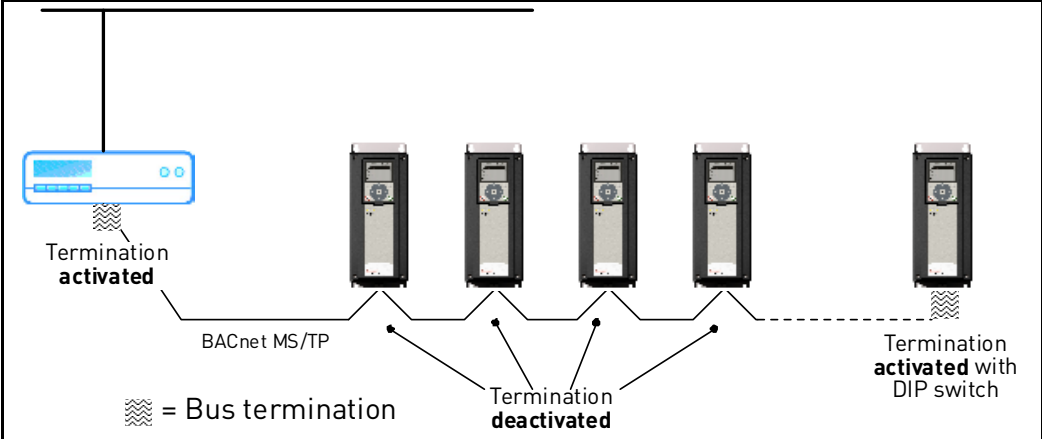
<h1>7</h1>	<p>Unless already done for the other control cables, cut free the opening on the VFD cover for the RS485 cable (protection class IP21).</p>	
<h1>8</h1>	<p>Remount the VFD cover and run the RS485 cables as shown in picture. NOTE: When planning the cable runs, remember to keep the distance between the fieldbus cable and the motor cable at a minimum of 30 cm.</p>	 <p style="text-align: right;">RS485 cables</p>
<h1>9</h1>	<p>The bus termination must be set for the first and the last device of the fieldbus line. See picture below. See also step 6 on page 14. We recommend that the first device on the bus and, thus, terminated was the Master device.</p>  <p style="text-align: center;">BACnet MS/TP</p> <p> = Bus termination </p> <p> Termination activated </p> <p> Termination deactivated </p> <p> Termination activated with DIP switch </p>	

5. Programming

Basic information on how to use the control keypad you will find in the Application Manual.

The navigation path to the fieldbus parameters may differ from application to application. The exemplary paths below apply to the Honeywell Smart VFD.

1. First ensure that the right fieldbus protocol is selected.

Navigate: Main Menu > I/O and Hardware (M5) > RS-485 (M5.7) OR Ethernet (M5.8) > Common settings (M5.7.1) > Protocol (P5.7.1.1) > Edit > (Choose protocol)

2. Select 'Fieldbus control' as the Remote Control Place.

Navigate: Main Menu > Quick Setup (M1) > Rem. Ctrl. Place (P1.15)
 OR
Navigate: Main Menu > Parameters (M3) > Start/Stop Setup (M3.2) > Rem. Ctrl. Place (P3.2.1)

3. Choose source of reference.

Navigate: Main Menu > Parameters (M3) > References (M3.3)

4. Set fieldbus parameters (M5.7 and M5.8). See below.

5.1 BACnet MS/TP parameters and monitoring values (M5.7.3)

Code	Parameter	Min	Max	Unit	Default	ID	Description
PARAMETERS							
P5.7.3.1.1	Baud rate	1	4	bd	1		Communication speed 1 = 9600 2 = 19200 3 = 38400 4 = 76800
P5.7.3.1.2	Autobauding	0	1		1		Automatic baudrate detection 0 = Off 1 = On; The automatically detected baud rate is then shown as value of parameter P5.7.3.1.1
P5.7.3.1.3	MAC address	1	127		1		
P5.7.3.1.4	Instance number	0	65535		0		Device Object's instance number. 0 = Automatically generated
P5.7.3.1.5	Communication time-out	0	65535	s	10		0 = Not used

Code	Parameter	Min	Max	Unit	Default	ID	Description
MONITORING VALUES							
P5.7.3.2.1	Fieldbus protocol status	1	3				1 = Stopped 2 = Operational 3 = Faulted
P5.7.3.2.2	Communication status	0.0	99.999		0.0		0-99 Number of messages with errors 0-999 Number of messages without communication errors
P5.7.3.2.3	Actual instance number	0	65535		Serial number		Shows actual Device Object's instance number
P5.7.3.2.4	Fault code	0	3		0		0 = None 1 = Sole Master 2 = Duplicate MAC ID 3 = Baud rate fault
P5.7.3.2.5	Control word			hex			See chapters 6.2 and 6.3.
P5.7.3.2.6	Status word			hex			See chapters 6.2 and 6.3.

Table 4. Parameters related with BACnet used through MS/TP

5.2 BACnet IP parameters and monitoring values

5.2.1 Ethernet common settings (M5.8.1)

Code	Parameter	Min	Max	Unit	Default	ID	Description
P5.8.1.1	IP address mode						See page 21.
P5.8.1.2	IP address						See page 21.
P5.8.1.3	Subnet mask						See page 21.
P5.8.1.4	Default gateway						See page 21.
P5.8.1.5	MAC address						See page 21.

Table 5. Common settings for BACnet IP

5.2.2 BACnet IP settings

Code	Parameter	Min	Max	Unit	Default	ID	Description
PARAMETERS							
P5.8.3.1.1	Instance number	0	4194304		0		Device Object's instance number 0 = Serial number
P5.8.3.1.2	Communication time-out	0	65535	s	0		0 = Not used
P5.8.3.1.3	Protocol in use	0	1		0		0 = Not used 1 = Used
MONITORING VALUES							
P5.8.3.2.1	Fieldbus protocol status	1	3				1 = Stopped 2 = Operational 3 = Faulted
P5.8.3.2.2	Communication status	0.0	99.999		0.0		0-99 Number of messages with errors 0-999 Number of messages without communication errors
P5.8.3.2.3	Actual instance number	0	65535		Serial number		Shows actual Device Object's instance number
P5.8.3.2.4	Control word			hex			See chapters 6.2 and 6.3.
P5.8.3.2.5	Status word			hex			See chapters 6.2 and 6.3.

Table 6. Parameters related with BACnet used through Ethernet

5.3 BACnet MS/TP parameter descriptions

5.3.1 BACnet MS/TP Parameters

P5.7.3.1.1 **BAUD RATE**

Select the communication speed for the network. The default value is 9600 baud. If value *Auto* is chosen this parameter is not editable.

P5.7.3.1.2 **AUTOBAUDING**

This function is set off by default. If the parameter is given value 1 the automatic baud rate detection is used. The automatically detected baud rate is then shown as value of parameter *P5.7.3.1.1 Baud rate*.

P5.7.3.1.3 **MAC ADDRESS**

The parameters of every device must be set before connecting to the bus. Especially the parameters *MAC address* and *Baud rate* must be the same as in the master's configuration.

The first parameter, MAC (Medium Access Control) address, must be unique on the network to which it is connected. The same MAC address may be used on a device on another network within the internetwork.

Addresses 128-254 are reserved for slaves. Addresses 1-127 are valid for both masters and slaves. The portion of the address space that is actually used for masters in a particular installation is determined by the value of the *Max_Master* property of the Device object.

It is recommended that MAC address 0 be reserved for use by the MS/TP router. 255 is reserved for broadcasts.

P5.7.3.1.4 **INSTANCE NUMBER**

The Device Object's Instance number must be unique across the entire BACnet internetwork because it is used to uniquely identify the BACnet devices. It may be used to conveniently identify the BACnet device from other devices during installation.

If 0 (default) is selected, the Device Instance number is read from the VFD. This unique number is then shown in the Monitor menu. If any other value than zero is selected, the value is used as Device Object's Instance number. The actual value is shown in the Monitor menu. The default value for this parameter is generated from the Ethernet MAC address. Last 2 octets will be used. XX.XX.XX.XX.FF.FF.

P5.7.3.1.5 **COMMUNICATION TIME-OUT**

BACnet board initiates a communication error if the board is a "sole master" in the network for a time defined with this parameter. '0' means that no fault is generated.

5.3.2 BACnet MS/TP monitoring values

P5.7.3.2.1 *FIELD BUS PROTOCOL STATUS*

Fieldbus Protocol Status tells the status of the protocol.

P5.7.3.2.2 *COMMUNICATION STATUS*

The *Communication status* shows how many error and how many good messages the frequency converter has received. The Communication status includes a common error counter that counts CRC and parity errors and a counter for good messages.

Only messages to the current slave in use are counted in the good messages, not MS/TP token packages.

Good messages	
0...999	Number of messages received without errors
Bad Frames	
0...99	Number of messages received with errors

Table 7.

P5.7.3.2.3 *ACTUAL INSTANCE NUMBER*

Shows the actual instance number.

P5.7.3.2.4 *FAULT CODE*

Shows BACnet MS/TP fault codes.

P5.7.3.2.5 *CONTROL WORD*

Shows the *Control Word* received from the bus.

P5.7.3.2.6 *STATUS WORD*

Shows the current *Status Word* that is sent to the bus.

5.4 BACnet IP parameter descriptions

5.4.1 Ethernet common settings

P5.8.1.1 **IP ADDRESS MODE**

Selectable alternatives are *DHCP* (Dynamic Host Configuration Protocol) and *Fixed*.

DHCP protocol gives IP addresses to new devices connecting to local network. This address is valid for a certain period of time.

A fixed IP address is specified manually and it does not change.

When the mode is changed from DHCP to Fixed the addresses will read

IP: 192.168.0.10

Subnet mask: 0.0.0.0

Default gateway: 0.0.0.0

P5.8.1.2 **IP ADDRESS**

An *IP address* is a series of numbers (like above) specific to the device connected to the Internet.

P5.8.1.3 **SUBNET MASK**

The network mask marks all the bits of an IP address for the identification of the network and the subnetwork.

P5.8.1.4 **DEFAULT GATEWAY**

Gateway address is the IP address of a network point that acts as an entrance to another network.

P5.8.1.5 **MAC ADDRESS**

The MAC address of the control board.

MAC address (Media Access Control) is a unique address given to each network host.

5.4.2 BACnet IP settings

P5.8.3.1.1 INSTANCE NUMBER

Similar to BACnet MS/TP device object instance number (see page 19).

P5.8.3.1.2 COMMUNICATION TIME-OUT

BACnet board initiates a communication error if the Ethernet connection is lost. Communication time-out parameters define the minimum delay between UDP packages received from the master. The timer is reset and started after each received UDP package. This parameter can be used if the master is periodically polling the slaves.

P5.8.3.1.3 PROTOCOL IN USE

BACnet/IP protocol can be enabled and disabled with this parameter. When the parameter value is set to "1" the BACnet/IP protocol is enabled and disabled when set to "0".

5.4.3 IP monitoring values

P5.8.3.2.1 FIELDBUS PROTOCOL STATUS

Fieldbus Protocol Status tells the status of the protocol.

P5.8.3.2.2 COMMUNICATION STATUS

The Communication status shows how many error and how many good messages the frequency converter has received. The Communication status includes a common error counter that counts CRC and parity errors and a counter for good messages.

Good messages	
0...999	Number of messages received without errors
Bad Frames	
0...99	Number of messages received with errors

Table 8. Communication status

P5.8.3.2.3 ACTUAL INSTANCE NUMBER

The Device Object's actual instance number. This monitoring value is needed when value 0 is written to parameter P5.8.3.1.1.

P5.8.3.2.3 CONTROL WORD

Shows the Control Word received from the bus.

P5.8.3.2.4 STATUS WORD

Shows the current Status Word that is sent to the bus.

6. Communications

6.1 Object types and properties supported

Property	Object Type		
	Device	Binary Value	Analog Value
Object Identifier	X	X	X
Object Name	X	X	X
Object Type	X	X	X
System Status	X		
Vendor Name	X		
Vendor Identifier	X		
Model Name	X		
Firmware Revision	X		
Appl Software revision	X		
Protocol Version	X		
Protocol Revision	X		
Services Supported	X		
Object Types supported	X		
Object List	X		
Max APDU Length	X		
Segmentation Support	X		
APDU Timeout	X		
Number ADPU Retries	X		
Max Master	X		
Max Info Frames	X		
Device Address Binding	X		
Database Revision	X		
Preset Value		X	X
Status Flags		X	X
Event State		X	X
Out-of-Service		X	X
Units			X
Priority Array		X*	X*
Relinquish Default		X*	X*
Polarity			
Active Text		X	
Inactive Text		X	

*Only with commandable values

Table 9. Object types and properties supported

6.1.1 Binary Value Object

Instance ID	Object Name	Description	Inactive / Active	Present Value Access Type
<i>BV0</i>	Ready State	Indicates whether the drive is ready or not	Not Ready / Ready	R
<i>BV1</i>	Run/Stop State	Indicates whether the drive is running or stopped	Stop / Run	R
<i>BV2</i>	Fwd/Rev State	Indicates the rotation direction of the motor	Fwd / Rev	R
<i>BV3</i>	Fault State	Indicates if a fault is active	OK / Fault	R
<i>BV4</i>	Alarm State	Indicates if an alarm is active	OK / Alarm	R
<i>BV5</i>	At Setpoint	Ref. Frequency reached	False / True	R
<i>BV6</i>	At Zero Speed	Motor Running at zero speed	False / True	R
<i>BV7</i>	fb_ProcessdataOut_01 Bit_0	ProcessDataOut1 bit 0	0 / 1	R
<i>BV8</i>	fb_ProcessdataOut_01 Bit_1	ProcessDataOut1 bit 1	0 / 1	R
<i>BV9</i>	fb_ProcessdataOut_01 Bit_2	ProcessDataOut1 bit 2	0 / 1	R
<i>BV10</i>	fb_ProcessdataOut_01 Bit_3	ProcessDataOut1 bit 3	0 / 1	R
<i>BV11</i>	fb_ProcessdataOut_01 Bit_4	ProcessDataOut1 bit 4	0 / 1	R
<i>BV12</i>	fb_ProcessdataOut_01 Bit_5	ProcessDataOut1 bit 5	0 / 1	R
<i>BV13</i>	fb_ProcessdataOut_01 Bit_6	ProcessDataOut1 bit 6	0 / 1	R
<i>BV14</i>	fb_ProcessdataOut_01 Bit_7	ProcessDataOut1 bit 7	0 / 1	R
<i>BV15</i>	Run/Stop CMD	Command to start drive (FB control is active)	Stop / Run	C
<i>BV17</i>	Reset Fault	Command to reset Active Fault from drive	0 / Reset	C
<i>BV18</i>	Stop By Coast	Stop Drive by coast	0 / 1	C
<i>BV19</i>	Stop By Ramp	Stop Drive by ramp	0 / 1	C
<i>BV20</i>	Quick Stop	Quick Stop	0 / 1	C
<i>BV21</i>	Zero Ramp	Stop by zero ramp	0 / 1	C
<i>BV22</i>	Hold Ramp	Hold ramp	0 / 1	C
<i>BV23</i>	BusCtrl	Activate Bus control	0 / 1	C
<i>BV24</i>	BusRef	Activate Bus reference	0 / 1	C
<i>BV25</i>	fb_control_word Bit_10	fb_control_word bit 10	0 / 1	C
<i>BV26</i>	fb_control_word Bit_11	fb_control_word bit 11	0 / 1	C
<i>BV27</i>	fb_control_word Bit_12	fb_control_word bit 12	0 / 1	C
<i>BV28</i>	fb_control_word Bit_13	fb_control_word bit 13	0 / 1	C

BV29	fb_control_word Bit_14	fb_control_word bit 14	0 / 1	C
BV30	fb_control_word Bit_15	fb_control_word bit 15	0 / 1	C

Table 10.

NOTE: Present Value Access Types: **R** = Read-only, **W** = Writeable, **C** = Commandable. Commandable values support priority arrays & relinquish defaults.

6.1.2 Analog Value Object

Instance ID	Object Name	Description	Units	Present Value Access Type
AV0	Frequency Setpoint	Frequency Setpoint	Hz	R
AV1	Output Frequency	Output Frequency	Hz	R
AV2	Motor Speed	Motor Speed	rpm	R
AV3	Load (power)	Motor Shaft Power	%	R
AV4	Kilowatt Hours total	Kilowatt Hour Counter (Total)	kWh	R
AV5	Motor Current	Motor Current	A	R
AV6	DC link Voltage	DC link Voltage	V	R
AV7	Motor Voltage	Motor Voltage	V	R
AV8	Unit Temperature	Heatsink Temperature	°C	R
AV9	Motor Torque	In % of motor nominal Torque	%	R
AV10	Operating Days	Operating Days (resettable)	Day	R
AV11	Operating Hours	Operating Hours (resettable)	Hour	R
AV12	Kilowatt Hours	Kilowatt Hours (resettable)	kWh	R
AV13	Torque Reference	Torque Reference	%	R
AV14	Temperature Rise	Calculated motor temperature 100,0% = nominal temperature of motor	%	R
AV15	fb_ProcessdataOut_01	Application specific	16 bit Resolution 1	R
AV16	fb_ProcessdataOut_02	Application specific	16 bit Resolution 1	R
AV17	fb_ProcessdataOut_03	Application specific	16 bit Resolution 1	R
AV18	fb_ProcessdataOut_04	Application specific	16 bit Resolution 1	R
AV19	fb_ProcessdataOut_05	Application specific	16 bit Resolution 1	R
AV20	fb_ProcessdataOut_06	Application specific	16 bit Resolution 1	R
AV21	fb_ProcessdataOut_07	Application specific	16 bit Resolution 1	R
AV22	fb_ProcessdataOut_08	Application specific	16 bit Resolution 1	R
AV23	Active Fault Code	Active Fault Code	-	R
AV24	Speed Reference	Speed Reference, percentage of nominal speed	%	C
AV25	Current Limit	Current Limit	A	W
AV26	Min Frequency	Minimum Frequency	Hz	W

AV27	Maximum Frequency	Maximum Frequency	Hz	W
AV28	Accel Time	Acceleration Time	s	W
AV29	Decel Time	Deceleration Time	s	W
AV30	fb_ProcessdataIn_01	Application specific	16 bits Resolution 1	C
AV31	fb_ProcessdataIn_02	Application specific	16 bits Resolution 1	C
AV32	fb_ProcessdataIn_03	Application specific	16 bits Resolution 1	C
AV33	fb_ProcessdataIn_04	Application specific	16 bits Resolution 1	C
AV34	AnyParam ID	ID number that is used in AV35	0 to 65535 resolution 1	W
AV35	AnyParam Value	Value of ID defined by AV34	32 bits Value	W
AV36*	Fb_Control_Word Lo16	Fixed Control Word First 16 bits 0-15	16 bits Resolution 1	C
AV37*	Fb_Control_Word Hi16	Fixed Control Word Last 16 bits 16-31	16 bits Resolution 1	C
AV38	Fb_Status_Word Lo16	Fixed Status Word First 16 bits 0-15	16 bits Resolution 1	R
AV39	Fb_Status_Word Hi16	Fixed Status Word Last 16 bits 16-31	16 bits Resolution 1	R

*ANSI/IEEE-754 floating point. Binary coding can be done only if the value has no decimals.

Table 11.

NOTE: Present Value Access Types: **R** = Read-only, **W** = Writeable, **C** = Commandable. Commandable values support priority arrays & relinquish defaults.

High and Low limits for the objects are defined in the application. See corresponding application for exact limits.

6.2 Control word bits

Bit	Name	Value = 1	Value = 0	Description
B0	Start/Stop	Start request	Stop request	Start/Stop command to application
B2	Fault reset	Reset faults	No action	Command to reset fault
B3-B15	Not used			

Table 12. Control Word bits

6.3 Status word bits

Bit	Name	Value = 1	Value = 0	Description
B0	Ready	Ready	Not ready	Indicates whether the drive is ready or not
B1	Run	Running	Stop	Indicates whether the drive is running or stopped
B2	Direction	Counterclockwise	Clockwise	Indicates the rotation direction of the motor
B3	Fault	Faulted	Not faulted	Indicates if a fault is active
B4	Alarm	Alarm	No alarm	Indicates if an alarm is active
B5	AtReference	True	False	Reference frequency reached
B6	ZeroSpeed	True	False	Motor running at zero speed
B7-B15	Not used			

Table 13. Status Word bits

7. Fault tracing

When an unusual operating condition is detected by the VFD control diagnostics, the drive initiates a notification visible, for example, on the keypad. The keypad will show the ordinal number of the fault, the fault code and a short fault description.

The fault can be reset with the Reset button on the control keypad or via the I/O terminal. The faults are stored in the Fault history menu which can be browsed. The different fault codes you will find in the table below. This fault table presents only the faults related to the fieldbus in use.

7.1 Typical fault conditions

Fault condition	Possible cause	Remedy
Termination resistor	Missing or excessive termination resistor.	Install termination resistors at both ends of the fieldbus line.
Cabling	<ul style="list-style-type: none"> • Supply or motor cables are located too close to the fieldbus cable • Wrong type of fieldbus cable • Too long cabling 	
Grounding	Inadequate grounding.	Ensure grounding in all points on the net
Connections	Faulty connections. <ul style="list-style-type: none"> • Excessive stripping of cables • Conductors in wrong terminals • Too loose connections of conductors 	
Parameter	<ul style="list-style-type: none"> • Faulty address • Overlapping slave addresses • Wrong baud rate • Wrong control place selected 	

Table 14. Typical fault conditions

7.2 Other fault conditions

The following fault tracing diagram will help you to locate and fix some of the most usual problems. If the problem persists contact your local distributor.

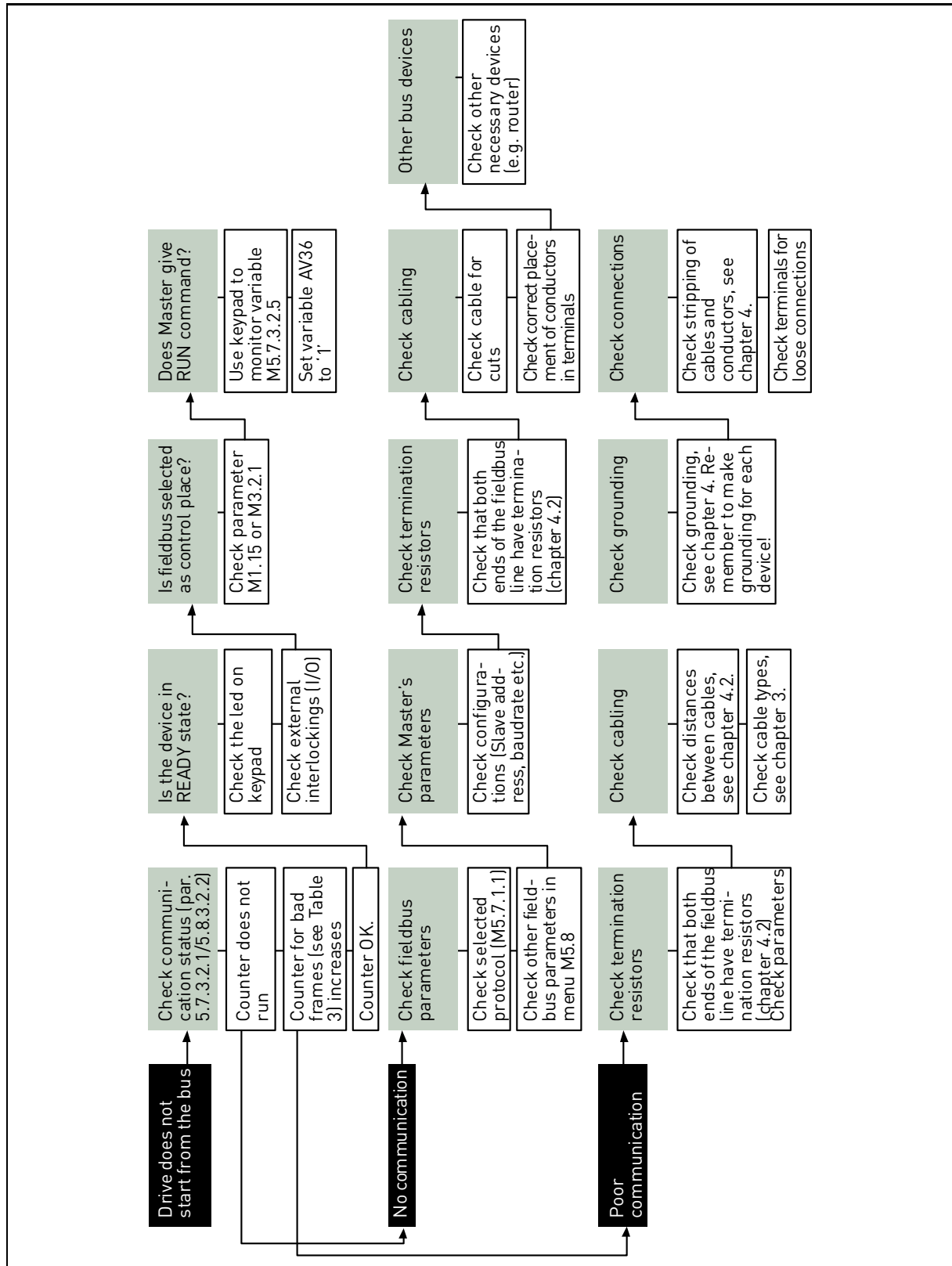

Figure 8. Fault tracing diagram for BACnet MS/TP

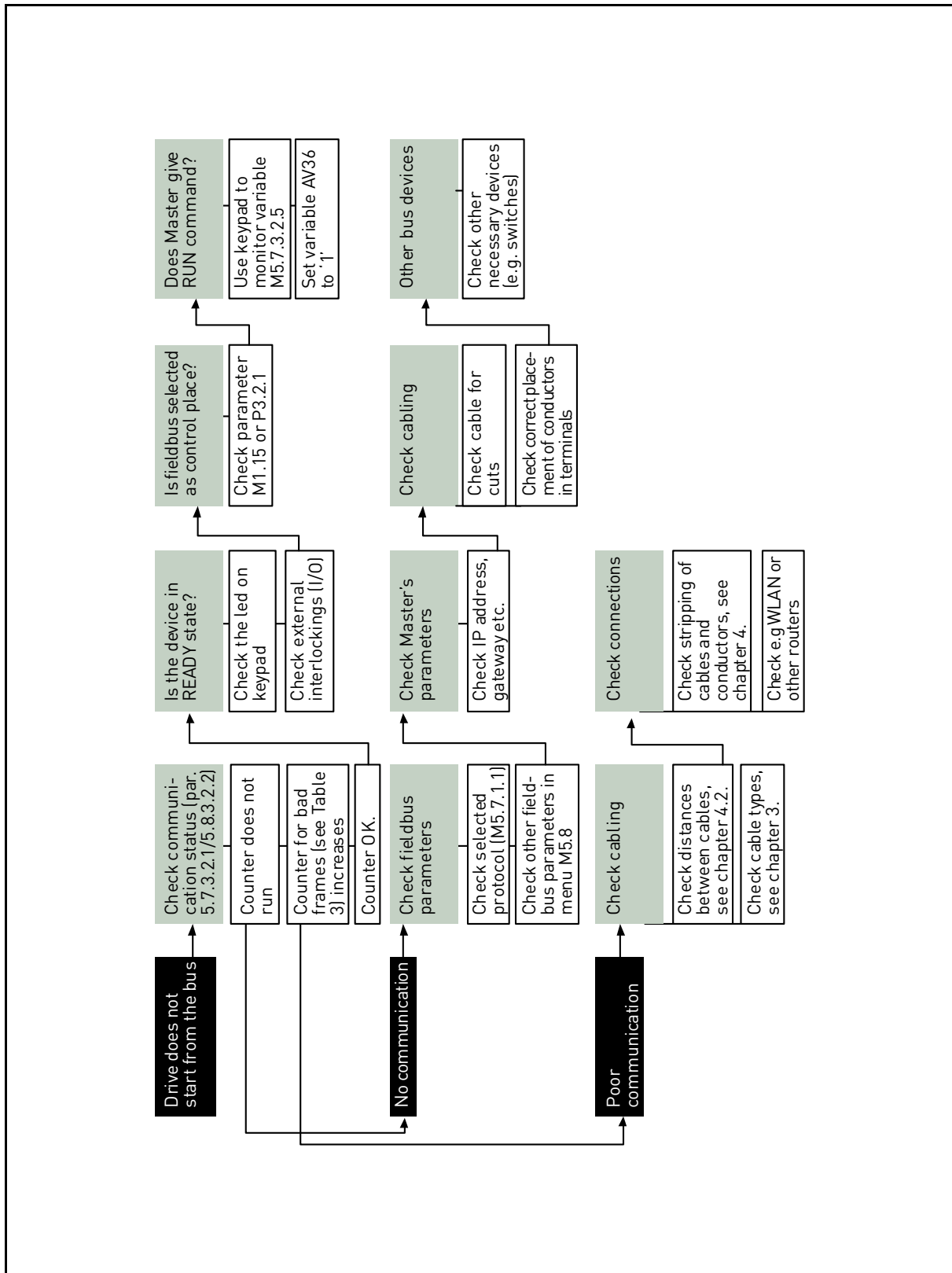

Figure 9. Fault tracing diagram for BACnet IP

8. Quick setup

Following these instructions, you can easily and fast set up your BACnet bus for use:

1	Choose control place. A. Press LOC/REM button on keypad to select <i>Remote Control Place</i> B. Select <i>Fieldbus</i> as remote control place: <i>Main Menu > Quick Setup (M1) > Rem. Ctrl. Place (P1.15) > FieldbusCTRL</i>
2	Make these settings in the master software A. Set <i>Control Word</i> to '0' (AV36 Fb_Control_Word_Lo16) B. Set <i>Control Word</i> to '1' (AV36 Fb_Control_Word_Lo16) C. Frequency converter status is RUN D. Set Reference value to '50' (50.00%) (AV24 Speed Reference). E. <i>Frequency setpoint</i> is 25.00 Hz (if MinFreq is 0.00 Hz and MaxFreq is 50.00 Hz) F. Set <i>Control Word</i> to '0' (AV36 Fb_Control_Word_Lo16) G. Frequency converter status is STOP.

9. Annex - Protocol implementation conformance statement

PROTOCOL IMPLEMENTATION CONFORMANCE STATEMENT (NORMATIVE)

(This annex is part of this Standard and is required for its use.)

BACnet Protocol Implementation Conformance Statement

Date: November 7, 2008

Vendor Name: Honeywell

Product Name: Honeywell Smart VFD - xxx (xxx = MAC ID)

Product Model Number: Honeywell SmartVFD

Applications Software Version: xxx

Firmware Revision: 1

BACnet Protocol Revision: 4

Product Description: Honeywell SmartVFD HVAC

BACnet Standardized Device Profile (Annex L): BACnet Application Specific Controller (B-ASC)

List all BACnet Interoperability Building Blocks Supported (Annex K): DS-RP-B, DS-RPM-B, DS-WP-B, DS-WPM-B, DM-DDB-B, DM-DOB-B.

Segmentation Capability:

- Segmented requests supportedWindow Size
- Segmented responses supportedWindow Size

Standard Object Types Supported:

An object type is supported if it may be present in the device. For each standard Object Type supported provide the following data:

1. Whether objects of this type are dynamically creatable using the CreateObject service
2. Whether objects of this type are dynamically deletable using the DeleteObject service

3. List of the optional properties supported
4. List of all properties that are writable where not otherwise required by this standard
5. List of proprietary properties and for each its property identifier, datatype, and meaning
6. List of any property range restrictions

Data Link Layer Options:

MS/TP master (Clause 9), baud rate(s): 9600,19200,34800, 76800 (supports autobaud detection)

BACnet IP, (Annex J)

Device Address Binding:

Is static device binding supported? (This is currently necessary for two-way communication with MS/TP slaves and certain other devices.) Yes No

Networking Options:

- Router, Clause 6 - List all routing configurations, e.g., ARCNET-Ethernet, Ethernet-MS/TP, etc.
- Annex H, BACnet Tunneling Router over IP
- BACnet/IP Broadcast Management Device (BBMD)

Does the BBMD support registrations by Foreign Devices? Yes No

Character Sets Supported:

Indicating support for multiple character sets does not imply that they can all be supported simultaneously.

- ANSI X3.4 IBM /Microsoft DBCS ISO 8859-1
- ISO 10646 (UCS-2) ISO 10646 (UCS-4) JIS C 6226

If this product is a communication gateway, describe the types of non-BACnet equipment/networks that the gateway supports.

Automation and Control Solutions

Honeywell International Inc.
1985 Douglas Drive North
Golden Valley, MN 55422
customer.honeywell.com

Honeywell Limited-Honeywell Limitée
35 Dynamic Drive
Toronto, Ontario M1V 4Z9