

80 W offline LED driver with PFC

1 Introduction

The use of high power LEDs in lighting applications is becoming increasingly popular due to rapid improvements in lighting efficiency, longer life, higher reliability and overall cost effectiveness. Dimming functions are more easily implemented in LEDs, and they are more robust and offer wider design flexibility compared to other light sources.

For this reason a demonstration board for driving high brightness and power LEDs has been developed. The STEVAL-ILL013V1 demonstration board is an 80 W offline dimmable LED driver with high power factor (PF) intended for fixed number of LEDs, the overall design of which is described in detail in this user manual.

The LED current can be set to 350 mA, 700 mA and 1000 mA, using jumpers. Additionally, a dimming function using a PWM (pulse width modulation) signal is implemented as well, allowing the user to set the LED brightness from 0% up to 100%. The demonstration board can be ordered using order code STEVAL-ILL013V1, and is shown in [Figure 1](#).

STEVAL-ILL013V1 main features

- 80 W LED driver
- 350 mA, 700 mA and 1 A LED current settings
- High efficiency (~90%)
- Wide input voltage range: 88 to 265 VAC
- High power factor: 0.99 for 110 VAC and 0.98 for 230 VAC
- Universal PWM input for dimming (external board required)
- Non-isolated SMPS
- Brightness regulation between 0% and 100%
- EMI filter implemented
- EN55015 and EN61000-3-2 compliant

Figure 1. STEVAL-ILL013V1 demonstration board

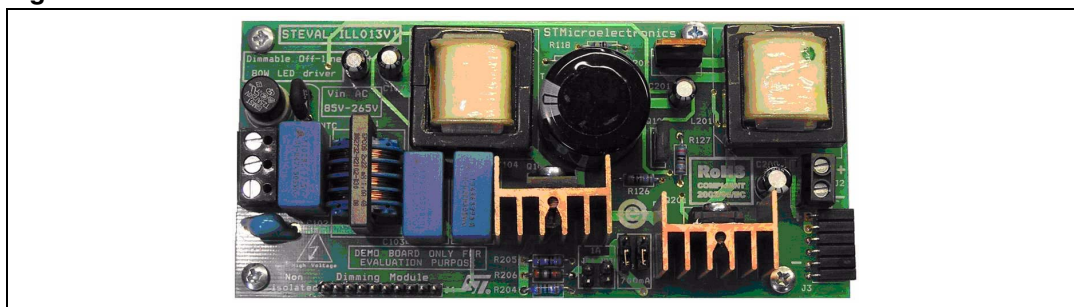

Contents

1	Introduction	1
2	Getting started	5
3	Design concept	6
4	STEVAL-ILL013V1 technical details	9
5	Schematic diagram	10
6	Bill of material	12
7	STEVAL-ILL013V1 performance	14
8	Dimming function	17
9	Measurement	19
	9.1 Output waveform measurement	19
	9.2 Power MOSFET turn ON and OFF time	22
	9.3 LED current ripple reduction	22
	9.4 Standard EN61000-3-2 measurement	23
	9.5 EMI measurement (EN55015)	26
10	Design features	32
	10.1 Proper startup circuit design	32
	10.2 Zero dimming design implementation	33
11	References and related materials	36
Appendix A	Design calculation	37
	A.1 Design specifications for a modified buck convertor	37
12	Revision history	42

List of tables

Table 1.	LED values for different output currents	5
Table 2.	Output LED current adjustment on the demonstration board	5
Table 3.	STEVAL-ILL013V1 demonstration board bill of material	12
Table 4.	Document revision history	42

List of figures

Figure 1.	STEVAL-ILL013V1 demonstration board	1
Figure 2.	STEVAL-ILL013V1 block schematic	6
Figure 3.	High PF boost converter design concept	7
Figure 4.	Modified buck converter with dimming design concept	8
Figure 5.	STEVAL-ILL013V1 with PWM module	9
Figure 6.	High PFC boost converter with the L6562A	10
Figure 7.	Modified buck converter with the L6562A	11
Figure 8.	Efficiency over the whole input voltage range	14
Figure 9.	Power factor for wide input voltage range	15
Figure 10.	Detailed power factor for wide input voltage range	15
Figure 11.	Total harmonic distortion for wide input voltage range	16
Figure 12.	Output LED current dimming capability	18
Figure 13.	Output LED current waveform ($I_{LED} = 350 \text{ mA}$)	19
Figure 14.	Output LED current for different LED voltages ($I_{LED} = 350 \text{ mA}$)	20
Figure 15.	Output LED current waveforms ($I_{LED} = 700 \text{ mA}$)	20
Figure 16.	Output LED current for different LED voltage ($I_{LED} = 700 \text{ mA}$)	21
Figure 17.	Output LED current waveform ($I_{LED} = 1000 \text{ mA}$)	21
Figure 18.	Output LED current for different LED voltage ($I_{LED} = 1000 \text{ mA}$)	22
Figure 19.	Power MOSFET turn ON and OFF measurement	22
Figure 20.	LED current ripple for the 100 nF output capacitor	23
Figure 21.	EN61000-3-2 analysis for LED current of 350 mA and V_{IN} from 85 V to 160 VAC	23
Figure 22.	EN61000-3-2 analysis for LED current of 350 mA and V_{IN} from 180 V to 265 VAC	24
Figure 23.	EN61000-3-2 analysis for LED current of 700 mA and V_{IN} from 85 V to 160 VAC	24
Figure 24.	EN61000-3-2 analysis for LED current of 700 mA and V_{IN} from 180 V to 265 VAC	24
Figure 25.	EN61000-3-2 analysis for LED current of 1000 mA and V_{IN} from 85 V to 160 VAC	25
Figure 26.	EN61000-3-2 analysis for LED current of 1000 mA and V_{IN} from 180 V to 265 VAC	25
Figure 27.	Average limit measurement from 150 kHz to 30 MHz ($I_{LED} = 350 \text{ mA}$)	26
Figure 28.	Quasi-peak limit measurement from 9 kHz to 150 kHz ($I_{LED} = 350 \text{ mA}$)	26
Figure 29.	Quasi-peak limit measurement from 150 kHz to 30 MHz ($I_{LED} = 350 \text{ mA}$)	27
Figure 30.	Average limit measurement from 150 kHz to 30 MHz ($I_{LED} = 700 \text{ mA}$)	27
Figure 31.	Quasi-peak limit measurement from 9 kHz to 150 kHz ($I_{LED} = 700 \text{ mA}$)	28
Figure 32.	Quasi-peak limit measurement from 150 kHz to 30 MHz ($I_{LED} = 700 \text{ mA}$)	28
Figure 33.	Average limit measurement from 150 kHz to 30 MHz ($I_{LED} = 1000 \text{ mA}$)	29
Figure 34.	Quasi-peak limit measurement from 9 kHz to 150 kHz ($I_{LED} = 1000 \text{ mA}$)	29
Figure 35.	Quasi-peak limit measurement from 150 kHz to 30 MHz ($I_{LED} = 1000 \text{ mA}$)	30
Figure 36.	Average limit measurement from 150 kHz to 30 MHz ($I_{LED} = 0 \text{ mA}$)	30
Figure 37.	Quasi-peak limit measurement from 9 kHz to 150 kHz ($I_{LED} = 0 \text{ mA}$)	31
Figure 38.	Quasi-peak limit measurement from 150 kHz to 30 MHz ($I_{LED} = 0 \text{ mA}$)	31
Figure 39.	Proper startup circuit design	32
Figure 40.	Proper startup using diode D104 and capacitor C110	33
Figure 41.	Improper startup without using diode D104 and capacitor C110	33
Figure 42.	Design improvement allowing zero dimming	34
Figure 43.	Voltage on capacitor C110 and output bus voltage of 400 V	35

2 Getting started

This section is intended to help designers begin evaluating the board quickly, describing how the board should be connected with the load and how the jumpers adjust the output LED current.

As mentioned in the introduction, the board has a nominal output power of 80 W and the output LED current can be set to 350 mA, 700 mA or 1 A. The LEDs are connected to one string. Basically, this means if the LED current is set to 350 mA, then the LED voltage should be approximately 228 V in order to provide output power of 80 W. If the LED current is set to 700 mA, then the LED voltage should be around 114 V. Finally, if the LED current is set to 1 A, then the LED voltage should be about 80 V. Assuming that a high brightness LED has (typically) a 3.5 V forward voltage drop, the number of LEDs for the 350 mA output current is 65, for the 700 mA output current it is 32 and for the output current of 1 A it is 23 (see [Table 1](#)). Of course, designers must recalculate the number of LEDs in cases where the LED has a forward voltage drop other than 3.5 V. If the output LED voltage is different than that given in [Table 1](#), output LED current precision will be influenced so is recommended that the total forward voltage drop across all the LEDs is as close as possible to the calculated output voltages shown in [Table 1](#).

Connect the LED string to the board using connector J2 or J3, being careful to observe the correct LED polarity (anode + and cathode –). Set the output LED current to 350 mA, 700 mA or 1 A, based on how many LEDs are connected to the output. The output LED current is set using jumpers JP1, JP2, JP3 and JP4, in accordance with the connection settings specified in [Table 2](#). It is not necessary to connect a dimming module with a PWM signal, because if the module is not used the LED brightness is set to maximum level (100% brightness). Finally, connect an input voltage to the demonstration board between 88 VAC and 265 VAC, and the LEDs begin illuminating.

Note: The LEDs cannot be connected during operation, when the input voltage is connected to the demonstration board. This is because in this case the output capacitor C208 = 0.47 μ F is charged to 400 V and can cause uncontrolled peak LED current.

Table 1. LED values for different output currents

Output LED current [mA]	Output LED voltage [V]	Number of LEDs for forward voltage drop 3.5 V
350	228	65
700	114	32
1000	80	23

Table 2. Output LED current adjustment on the demonstration board

Jumper	350 mA	700 mA	1000 mA
JP1	Not connected	Connected	Not connected
JP2	Not connected	Connected	Not connected
JP3	Not connected	Not connected	Connected
JP4	Not connected	Not connected	Connected

3 Design concept

The STEVAL-ILL013V1 block schematic is illustrated in [Figure 2](#). As shown, the design is divided into two main topologies. The first is a high PF (power factor) boost converter, and the second is a modified buck converter. As an additional board, any external PWM generator can be used for LED brightness regulation. If no PWM generator is connected to the STEVAL-ILL013V1, the LED brightness is pre-adjusted to 100%.

There are two main reasons the high PF boost converter is designed on the STEVAL-ILL013V1 demonstration board. The first is the requirement for lighting equipment with an input active power higher than 25 W to comply with standard EN61000-3-2 (harmonic current distortion). Thanks to the high PF converter, compliance to the standard is achieved with no difficulty. The second reason is that a high input voltage (in this case 400 V) is needed for the modified buck converter, because it is, in fact, a buck converter and thus the input voltage must be higher than the output voltage. The output LED voltage can be up to 228 V, as was shown in [Table 1](#). An additional advantage of the high PF converter is its wide input voltage range. This allows the demonstration board to be used either in either the European or US markets. A more detailed description of the high PF boost converter is provided in the EVL6562A-TM-80W data brief (see [Section 11: References and related materials: 1](#)).

The second converter is designed as a constant current source, as it ensures the best lighting performance from the LEDs. Concerning the topology, the “modified buck” has been chosen, “modified” insofar as the power switch is connected to ground (instead of the high-side switch, as in a standard buck topology) and therefore it is easier to control the switch. The design uses a FOT (fixed off-time) network, operating in CCM (continuous conduction mode) and thanks to this principle the overall solution is very simple and cost effective. All equations needed for proper modified buck converter design are described in application note AN2928 (see [Section 11: References and related materials: 2](#)).

Figure 2. STEVAL-ILL013V1 block schematic

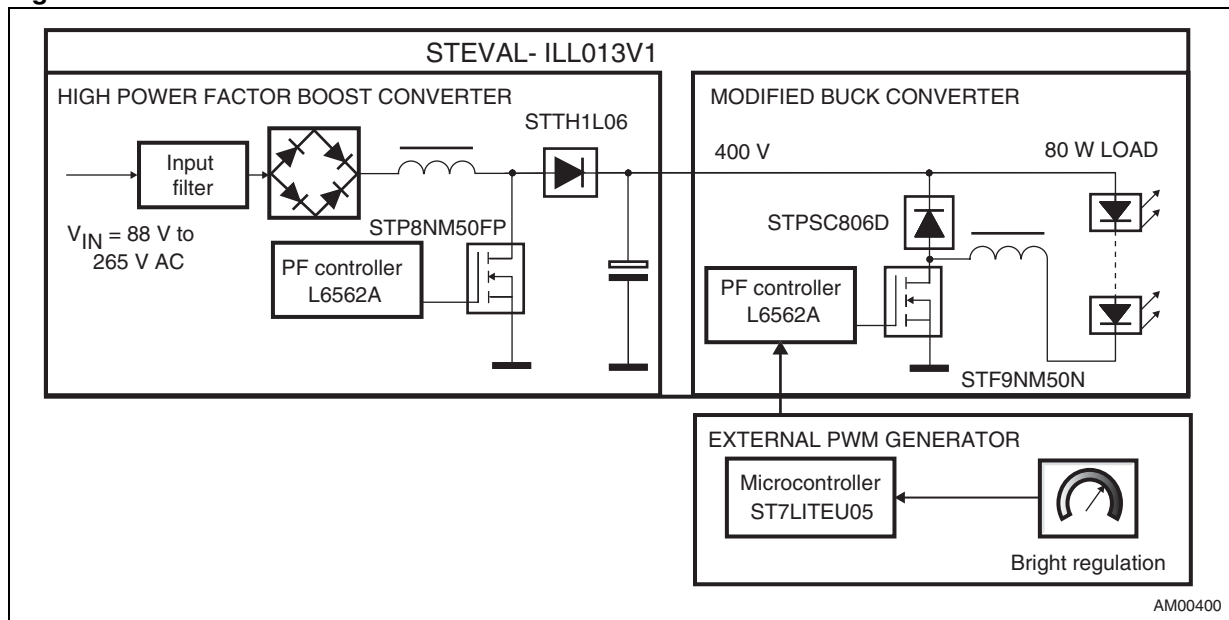

Figure 3 illustrates a high PF boost converter design concept. Two additional features are implemented in the application and these improvements are shown in the blue segments. The first improves circuit behavior during startup (see Section 10.1 for a description) and the second allows the dimming of the LED down to 0%, or no LED brightness (description provided in Section 10.2).

Figure 4 shows the design concept of a modified buck converter with a dimming function. The output LED current is adjusted by setting the proper sense resistor size via the jumpers (to adjust maximum LED current), together with the proper setting of the capacitor used in the FOT network (adjust minimum LED current). The external PWM generator provides a PWM signal between 0 and 100% for brightness regulation. This signal is connected through a diode to the current sense pin and allows control of LED brightness.

Figure 3. High PF boost converter design concept

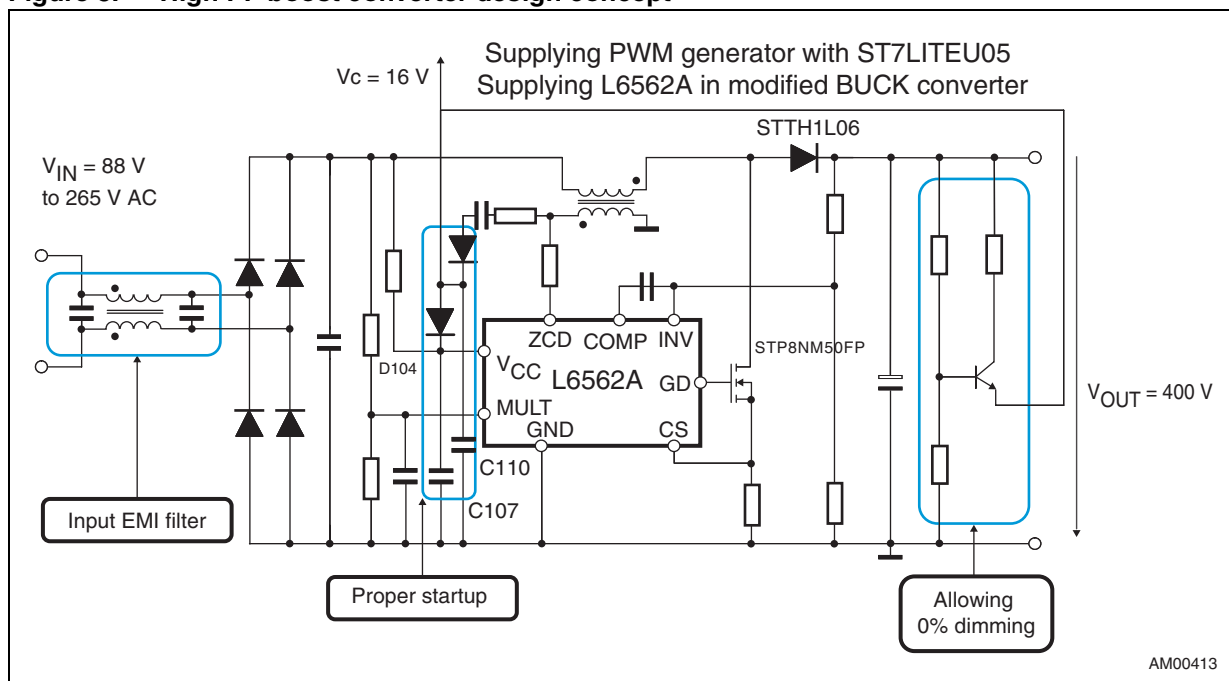
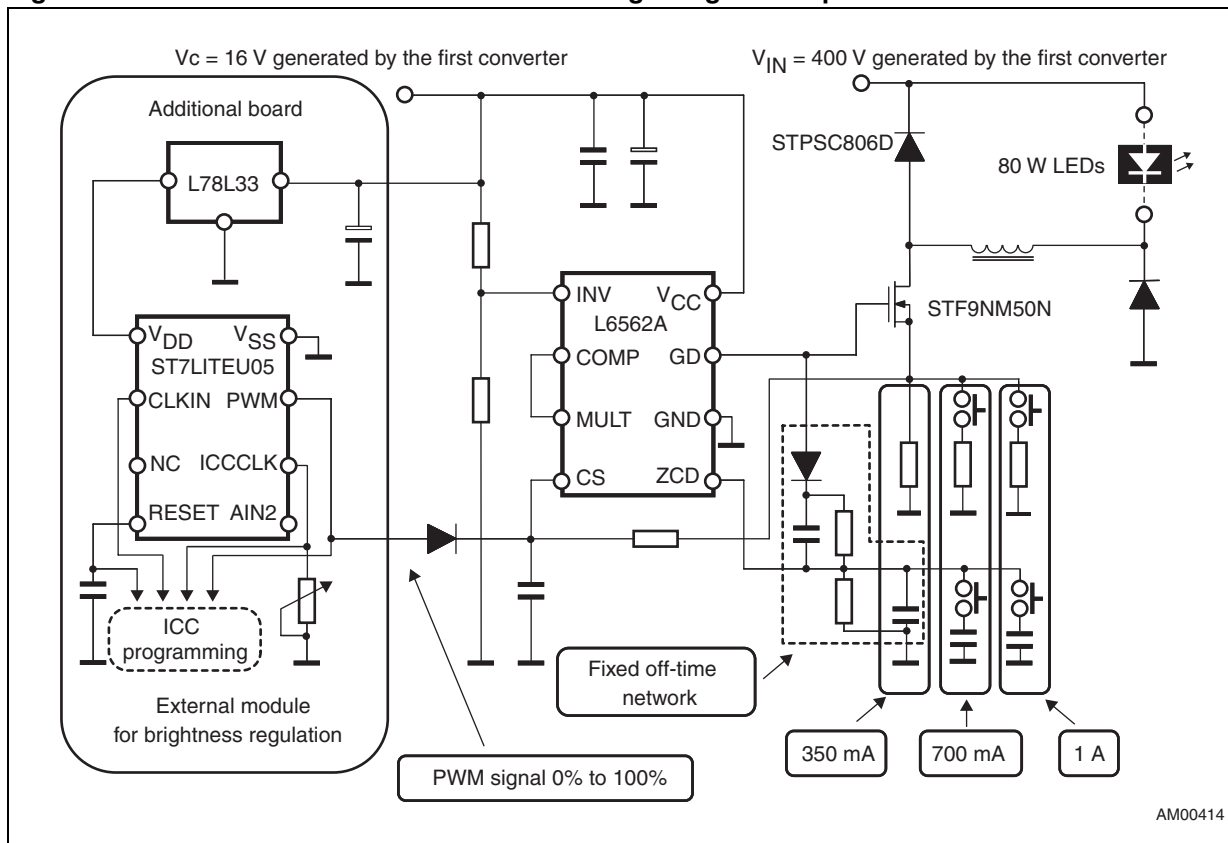

Figure 4. Modified buck converter with dimming design concept



AM00414

4 STEVAL-ILL013V1 technical details

- 80 W LED driver
- 350 mA, 700 mA and 1 A LED current settings
- PF = 0.99 with $V_{IN} = 110$ V or PF = 0.98 with $V_{IN} = 230$ V
- THD (total harmonic distortion) = 4.6 and $V_{IN} = 110$ V or THD = 10.3 and $V_{IN} = 230$ V
- High PFC boost converter operating in transition mode
- Modified buck converter working in CCM and using FOT network
- Switching frequency $f = 125$ kHz / 350 mA (modified buck converter)
- Switching frequency $f = 69$ kHz / 700 mA (modified buck converter)
- Switching frequency $f = 55$ kHz / 1000 mA (modified buck converter)
- The same inductor and transformer core used (E25)
- Supply voltage provided for external PWM generator
- Board size: 130 mm x 60 mm x 27 mm
- Optional external PWM generator (non isolated)
- Full brightness if PWM generator is not connected
- Two output connectors for LEDs
- High efficiency (~90%)
- Wide input voltage range: 88 V to 265 VAC
- Brightness regulation between 0% and 100%
- EMI filter implemented
- EN55015 and EN61000-3-2 tested

Figure 5. STEVAL-ILL013V1 with PWM module

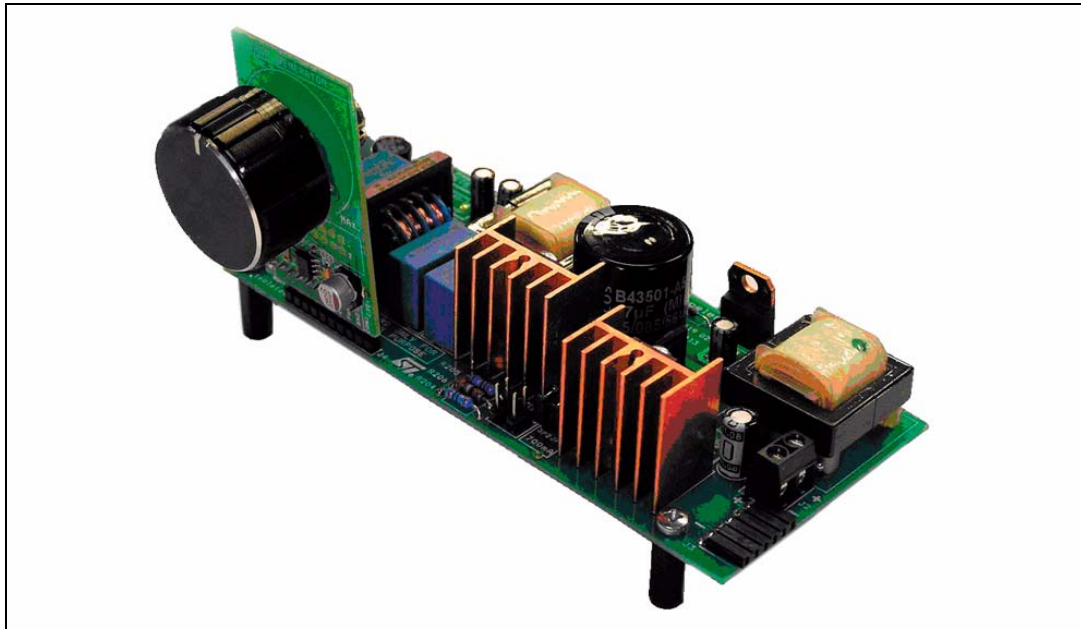

5 Schematic diagram

Figure 6. High PFC boost converter with the L6562A

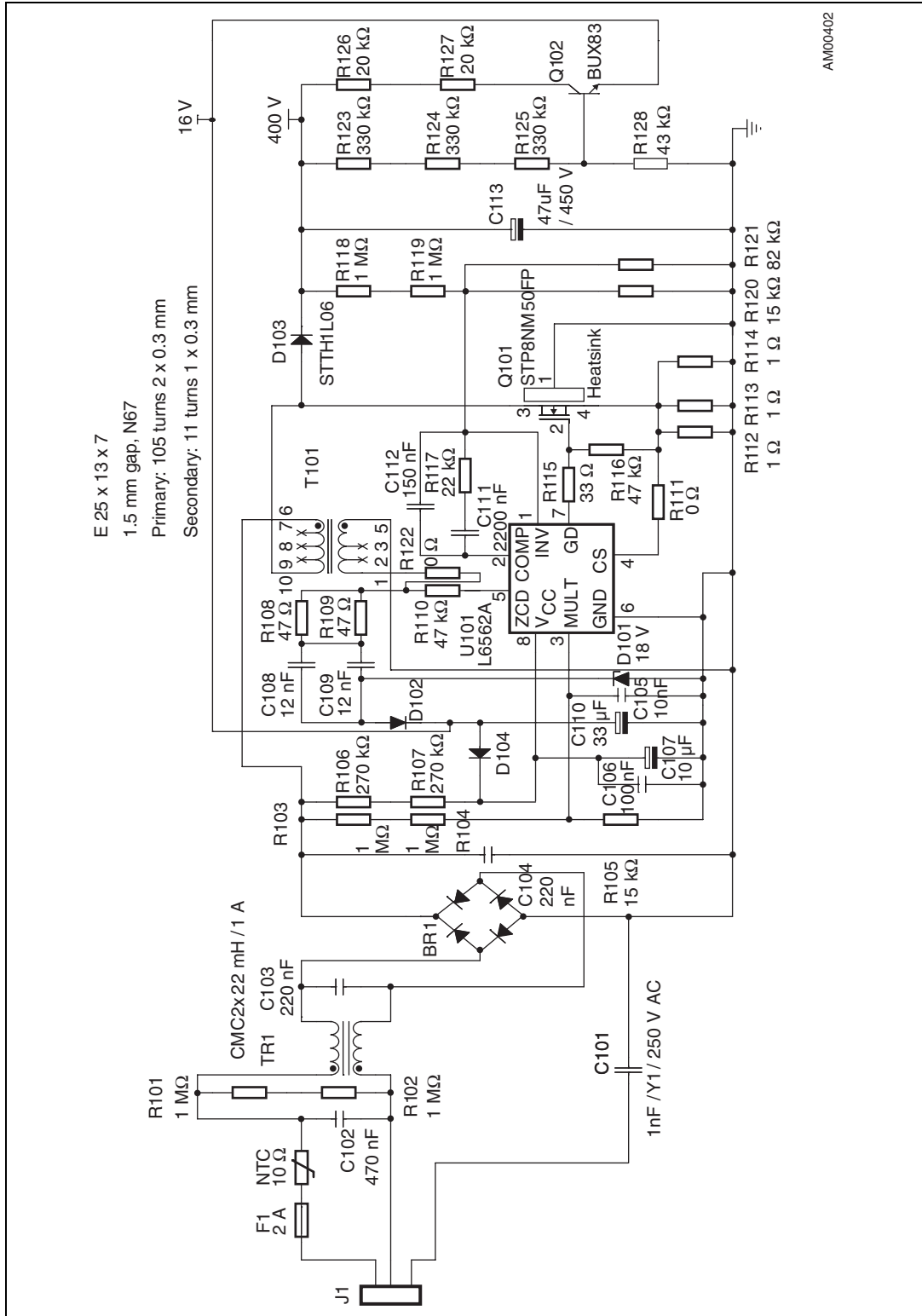

AM00402

Figure 7. Modified buck converter with the L6562A

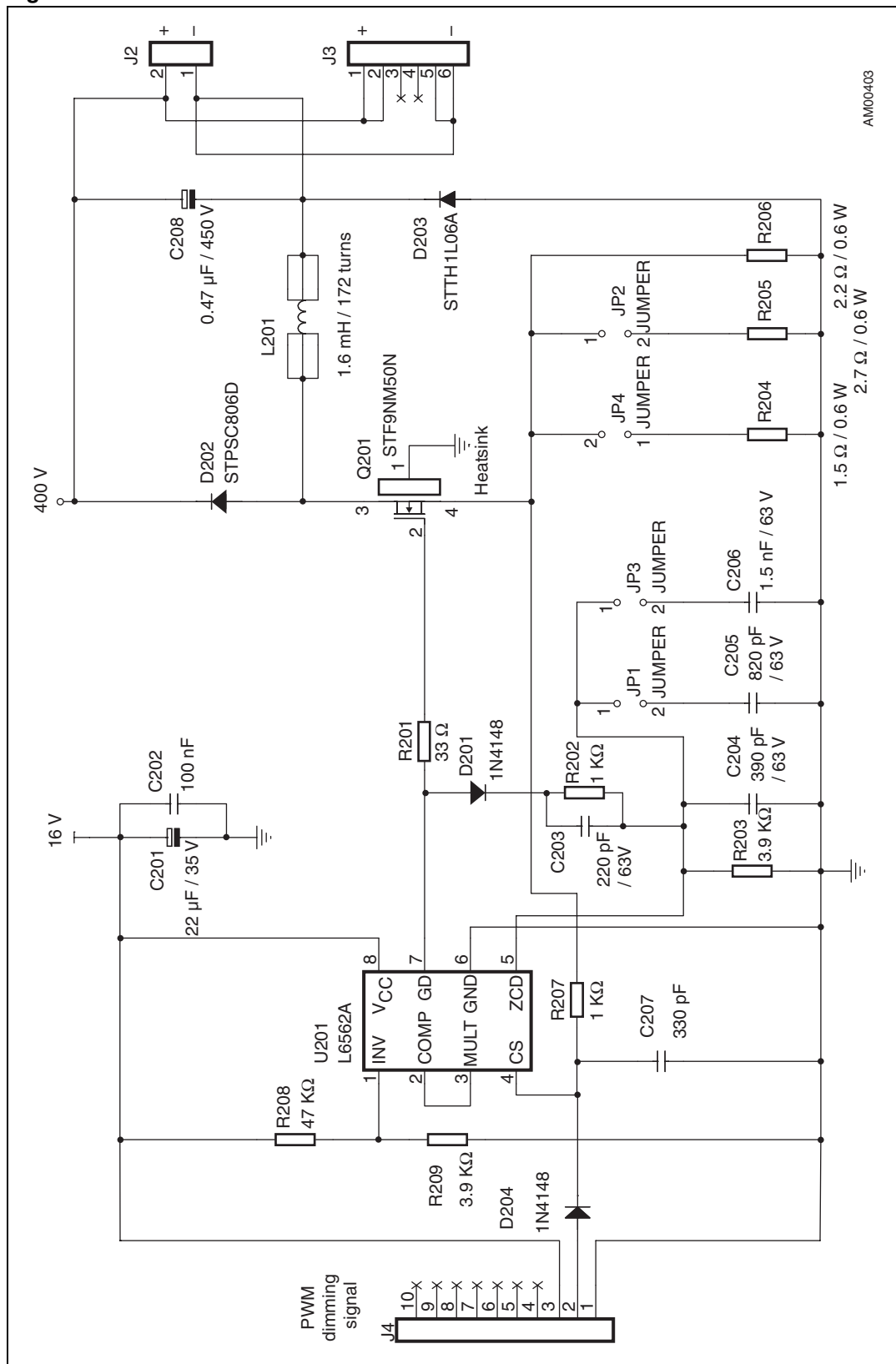

AM00403



6 Bill of material

Table 3. STEVAL-ILL013V1 demonstration board bill of material ⁽¹⁾

I	Q	Reference	Part	Note	Manufacturer	Order code
1	1	J1	Socket	Input socket		
2	1	F1	Fuse	2.5 A / 250 V		
3	1	F1	Fuse socket	Socket		
4	1	NTC	10 Ω	NTC thermistor	EPCOS	B57235S100M
5	1	TR1	2 x 22 mH / 1 A	Common mode choke	EPCOS	B82732R2102B030
6	1	BR1	1 A / 250 V	Diode bridge		
7	1	C101	1 nF / 250 VAC	Y1 capacitor	Murata Manufacturing Co., Ltd.	DE1E3KX102MA5B
8	1	C102	470 nF / 265 VAC	X2 capacitor	EPCOS	B32922C3474K
9	2	C103, C104	220 nF / 265 VAC	X2 capacitor	EPCOS	B32922C3224M
10	1	C105	10 nF / 63 V	SMD capacitor 1206		
11	2	C106, C202	100 nF / 63 V	SMD capacitor 1206		
12	1	C107	10 μ F / 35 V	Electrolytic capacitor		
13	2	C108, C109	12 nF / 63 V	SMD capacitor 1206		
14	1	C110	33 μ F / 35 V	Electrolytic capacitor		
15	1	C111	2200 nF / 25 V X7R	SMD 1206 ceramic capacitor	AVX	12063C225KAT2A
16	1	C112	150 nF / 50 V	SMD capacitor 1206		
17	1	C113	47 μ F / 450 V	Electrolytic capacitor	EPCOS	B43501A5476M000
18	1	D101	18 V / 0.5 W	Zener diode		
19	4	D102, D104, D201, D204	1N4148	SMD diode		
20	1	D103	STTH1L06U	SMB package	STMicroelectronics	STTH1L06U
21	2	U101, U201	L6562A	PFC controller	STMicroelectronics	L6562AD
22	4	R101, R102, R103, R104	1 M Ω	SMD resistors 1206		
23	1	R105	15 k Ω	SMD resistors 1206		
24	2	R106, R107	270 k Ω	SMD resistors 1206		
25	2	R108, R109	47 Ω	SMD resistors 1206		
26	3	R110, R116, R208	47 k Ω	SMD resistors 1206		
27	2	R111, R122	0 Ω	SMD resistors 1206		
28	3	R112, R113, R114	1 Ω / 1%	SMD resistors 1206		
29	2	R115, R201	33 Ω	SMD resistors 1206		

Table 3. STEVAL-ILL013V1 demonstration board bill of material (continued)⁽¹⁾

I	Q	Reference	Part	Note	Manufacturer	Order code
30	1	R117	22 kΩ	SMD resistors 1206		
31	2	R118, R119	1 MΩ / 1%	Axial resistor 0.6 W / 1%		
32	1	R120	15 kΩ / 1%	SMD resistors 1206		
33	1	R121	82 kΩ / 1%	SMD resistors 1206		
34	3	R123, R124 R125	330 kΩ	SMD resistors 1206		
35	2	R126, R127	20 kΩ	Axial resistor 0.6 W		
36	1	R128	43 kΩ	SMD resistor 1206		
37	1	T101	Transformer	E25/13/7 1.5 mm gap , N67 Primary: 105 turns 2 x 0.3 Secondary: 11 turns 1 x 0.3		
38	1	Q101	STP8NM50	Power MOSFET	STMicroelectronics	STP8NM50FP
39	1	Q102	BUX87	Bipolar transistor	STMicroelectronics	BUX87
40	2	Heat sink		Heat sink for MOSFETs		
41	2	R202, R207	1kΩ	SMD resistors 1206		
42	2	R203, R209	3900 Ω	SMD resistors 1206		
43	1	R204	1.5 Ω / 0.6 W	Axial resistor		
44	1	R205	2.7 Ω / 0.6 W	Axial resistor		
45	1	R206	2.2 Ω / 0.6 W	Axial resistor		
46	1	C201	22 μF / 35 V	Electrolytic cap		
47	1	C203	220 pF / 63 V	SMD capacitor 1206		
48	1	C204	390 pF / 63 V	SMD capacitor 1206		
49	1	C205	820 pF / 63 V	SMD capacitor 1206		
50	1	C206	1.5 nF / 63 V	SMD capacitor 1206		
51	1	C207	330 pF / 63 V	SMD capacitor 1206		
52	1	C208	0.47 μF / 450 V	Electrolytic capacitor	EPCOS	B43827A5474M000
53	1	D202	STPSC806D	Silicon carbide diode	STMicroelectronics	STPSC806D
54	1	D203	STTH1L06A	SMA package	STMicroelectronics	STTH1L06A
55	4	JP1, JP2 JP3, JP4	Jumper	Two pin connector		
56	2	JPJ1, JPJ2	Jumper	Jumpers		
57	1	J2	Socket	Output socket		
58	1	J3	Socket	Output socket		
59	1	J4	Socket	PWM socket		
60	1	Q201	STF9NM50N	Power MOSFET	STMicroelectronics	STF9NM50N
61	1	L201	1.6 mH	E25/13/7 2 mm gap N67, 172 turns 1 x 0.28		

1. The power MOSFET STF9NM50N can be replaced by STF10NM60N.

7 STEVAL-ILL013V1 performance

[Figure 8](#) shows the efficiency of the STEVAL-ILL013V1 (measured also with an external PWM generator) for the output LED current 350 mA, 700 mA and 1 A, over the entire input voltage range.

Measured efficiency for the input voltage of 230 V was above 90% (90.49% for the 350 mA output LED current, 90.53% for the 700 mA output LED current, and 90.3% for the 1 A output LED current)

Efficiency for the input voltage of 110 V was above 87% (88.05% for the 350 mA output LED current, 88.2% for the 700 mA output LED current and 87.37% for the output LED current of 1 A).

Measured PF for the output LED current of 350 mA, 700 mA and 1 A is shown in [Figure 9](#) and [Figure 10](#). PF for the input voltage of 110 VAC is 0.99, and 0.98 for the input voltage of 230 VAC.

THD is demonstrated in [Figure 11](#), and as it can be observed is below 12% over the whole input voltage range.

Note: LE UW E3B OSTAR® LEDs from OSRAM were used as the load (see [Section 11: References and related materials: 6.](#)).

Figure 8. Efficiency over the whole input voltage range

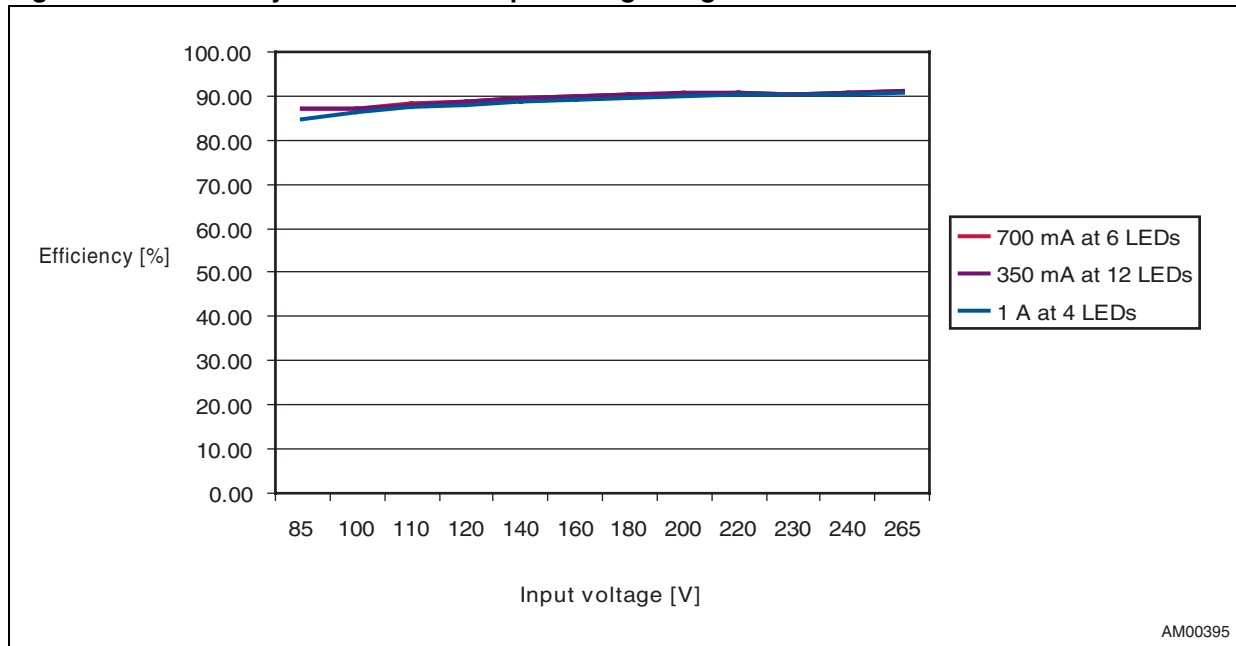

Figure 9. Power factor for wide input voltage range

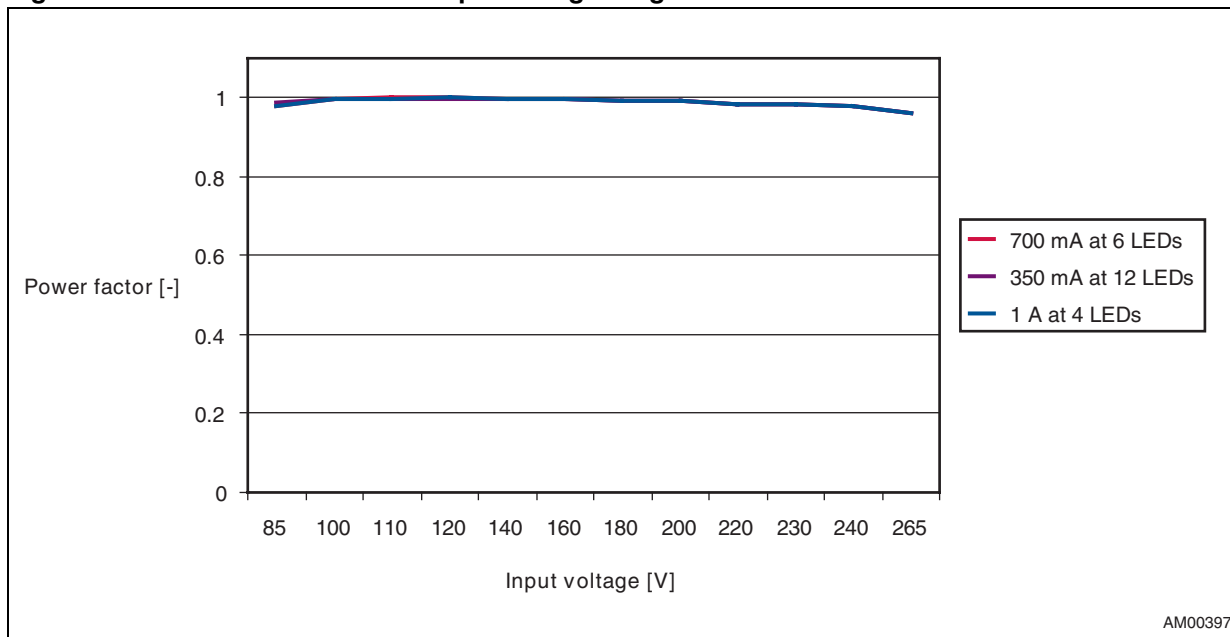

Figure 10. Detailed power factor for wide input voltage range

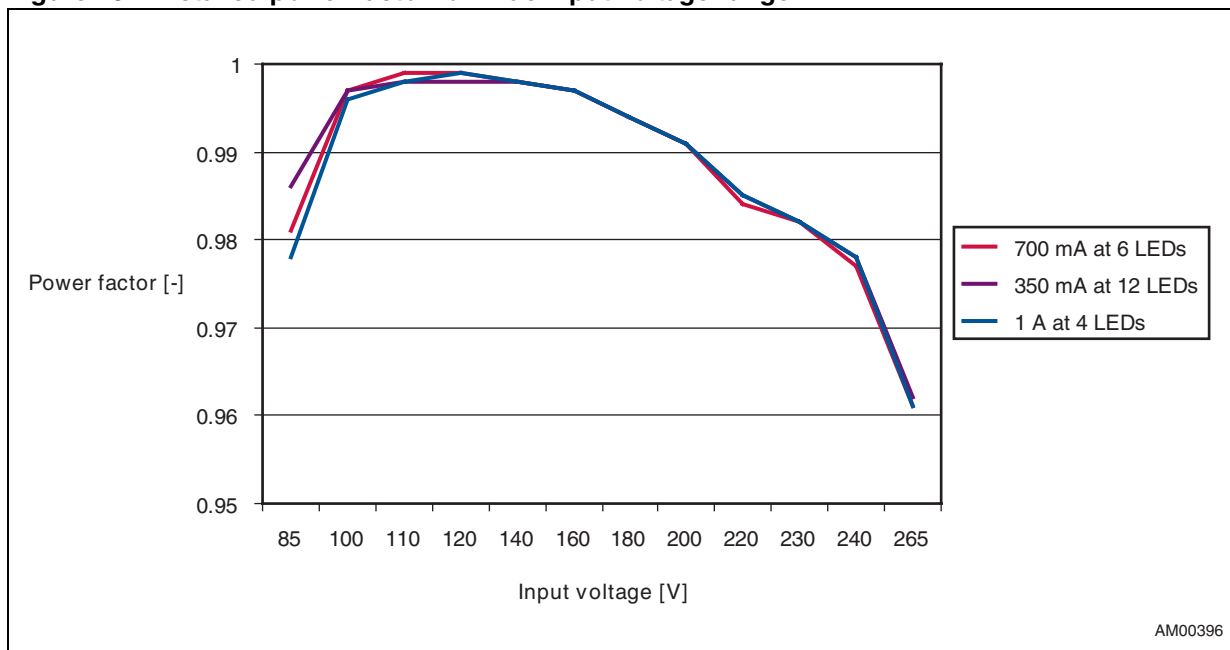
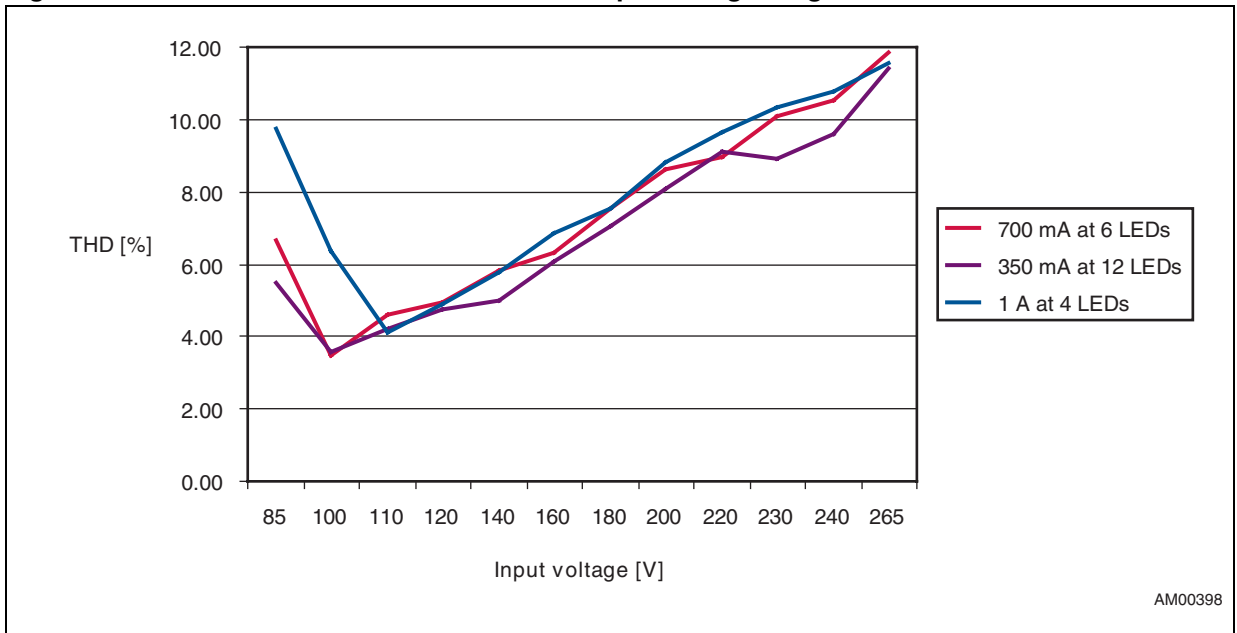

Figure 11. Total harmonic distortion for wide input voltage range



8 Dimming function

LEDs as a light source are very often used in applications where the brightness regulation is required. Their biggest advantage is that their minimum brightness can be easily regulated by changing their current, and they are stable even at very low brightness. Generally, there are two basic concepts regarding how the brightness is regulated. The first is called “analog dimming”, which means that the brightness is regulated by changing the continuous forward LED current. This concept is not used on the STEVAL-ILL013V1. The second solution is to use a low frequency (~200 Hz) PWM signal and change the brightness by pulse width modulation. This is the approach used in the design of the STEVAL-ILL013V1. Any external PWM generator can be used for brightness regulation, but it should be taken into account that the STEVAL-ILL013V1 is not isolated.

In order to demonstrate the dimming function on the STEVAL-ILL013V1, an external PWM generator using STMicroelectronics’ ST7LITEU05 microcontroller was connected to the board, and the output LED current was measured. The microcontroller generates a PWM signal with a frequency of 250 Hz. The duty cycle is set by a potentiometer from 0% up to 100%. The result with duty cycles of 50%, 10% and 2% is shown in [Figure 12](#). The input voltage was, in this case, 230 VAC and the output LED current was set to 350 mA. It is also possible to achieve LED brightness regulation below 2%. In this case the nominal LED current is slightly decreased.

Figure 12. Output LED current dimming capability

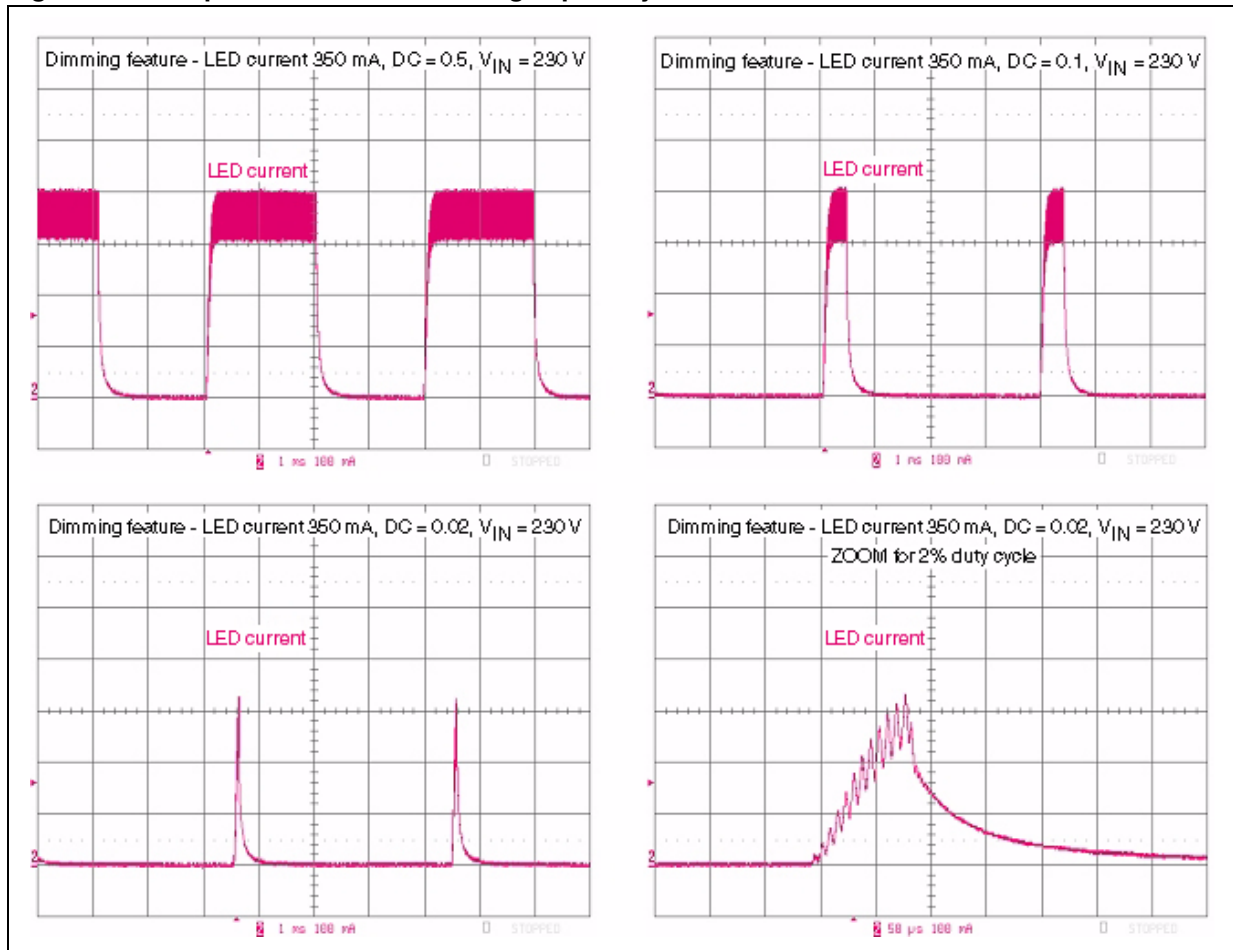

9 Measurement

9.1 Output waveform measurement

Figure 13 shows the output LED current waveform. The LED current was set to 350 mA and, as shown, the current ripple is 92 mA and the switching frequency for the modified buck converter is 125 kHz. The input voltage was 230 VAC and 12 LEDs were used as the load (OSTAR LED LE UW E3B; see Section 11: References and related materials 6).

The output LED current slightly varies with the output voltage, as explained in detail in application note AN2928, (Section 11: References and related materials 2) and therefore this design is optimal for a fixed number of LEDs. The output LED current accuracy for different LED voltages is demonstrated in Figure 14.

Figure 13. Output LED current waveform ($I_{LED} = 350 \text{ mA}$)

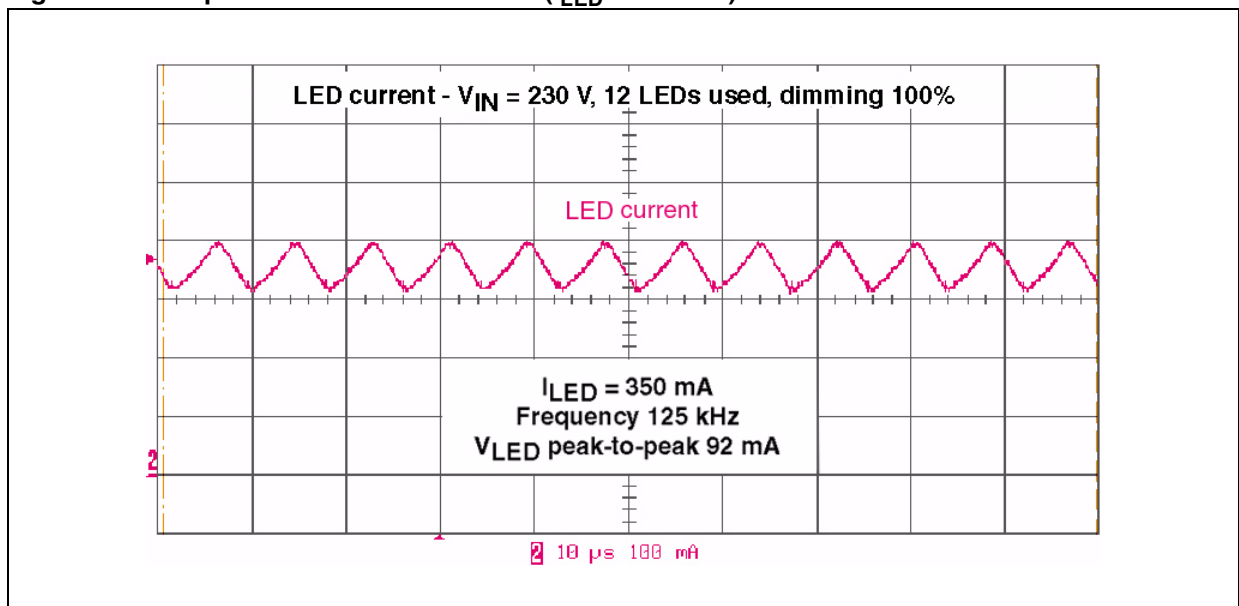

Figure 14. Output LED current for different LED voltages ($I_{LED} = 350 \text{ mA}$)

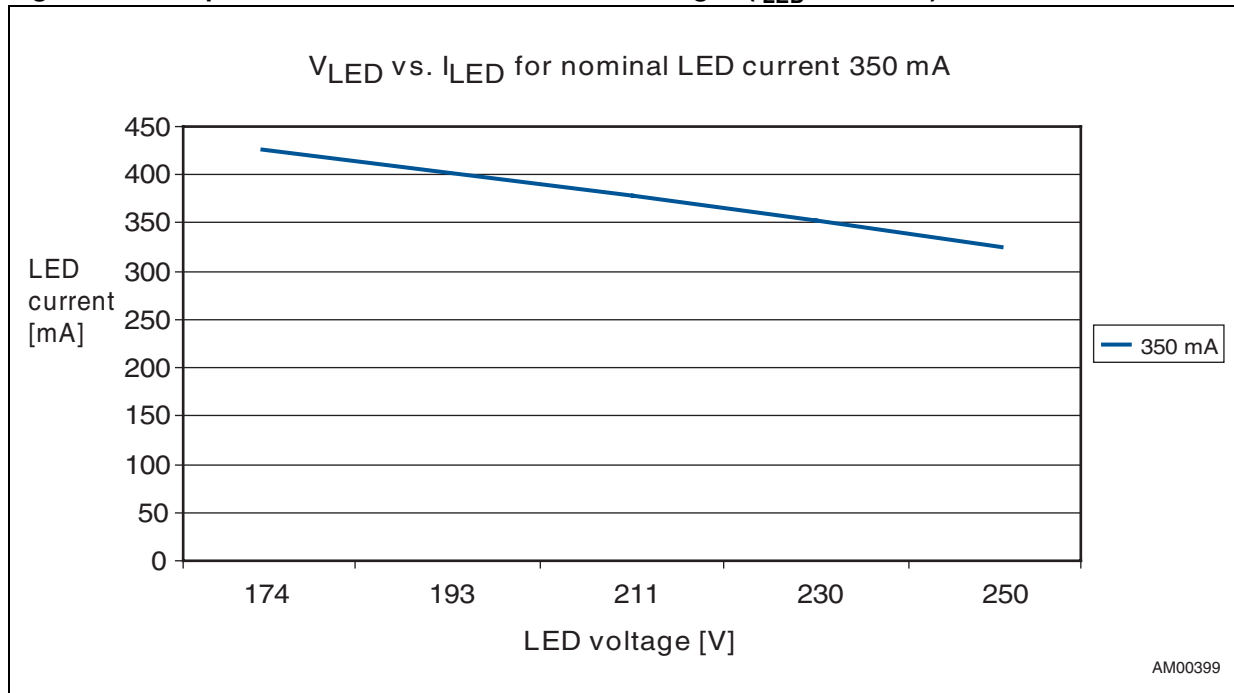

Figure 15 shows the output LED current waveform for the LED current of 700 mA. The current ripple is, in this case, 333 mA and the switching frequency for the modified buck converter is 69 kHz. The input voltage was 230 AC and 6 LEDs were used as the load (OSTAR LED LE UW E3B see [Section 11: References and related materials: 6](#)). The output LED current accuracy for the different LED voltages is shown in [Figure 16](#).

Figure 15. Output LED current waveforms ($I_{LED} = 700 \text{ mA}$)

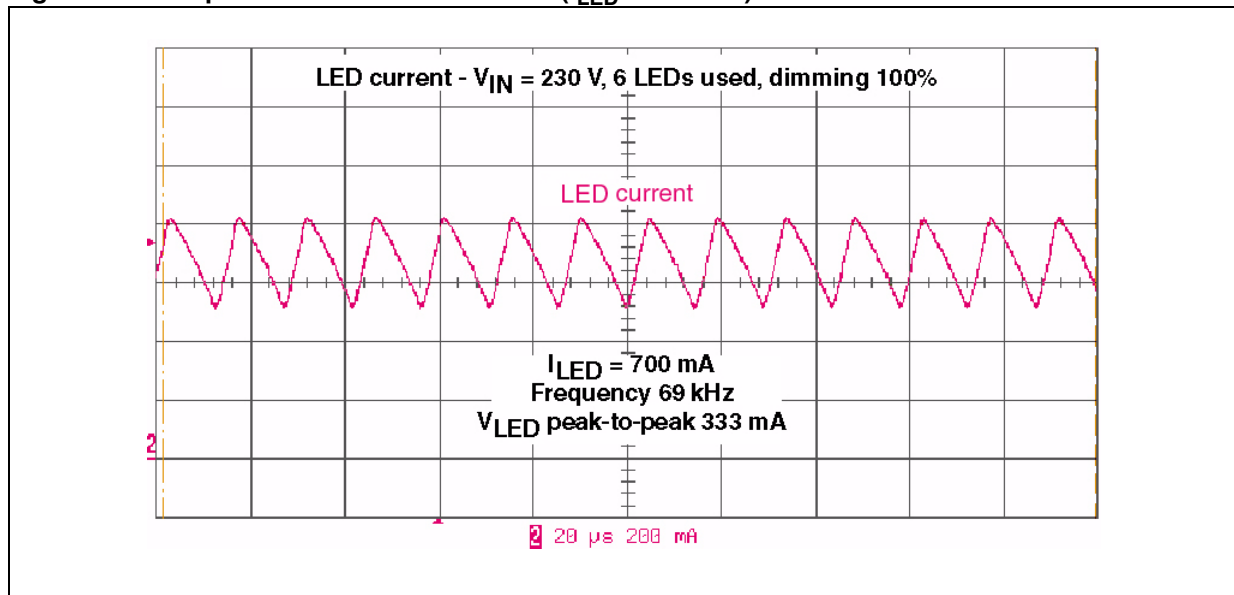

Figure 16. Output LED current for different LED voltage ($I_{LED} = 700 \text{ mA}$)

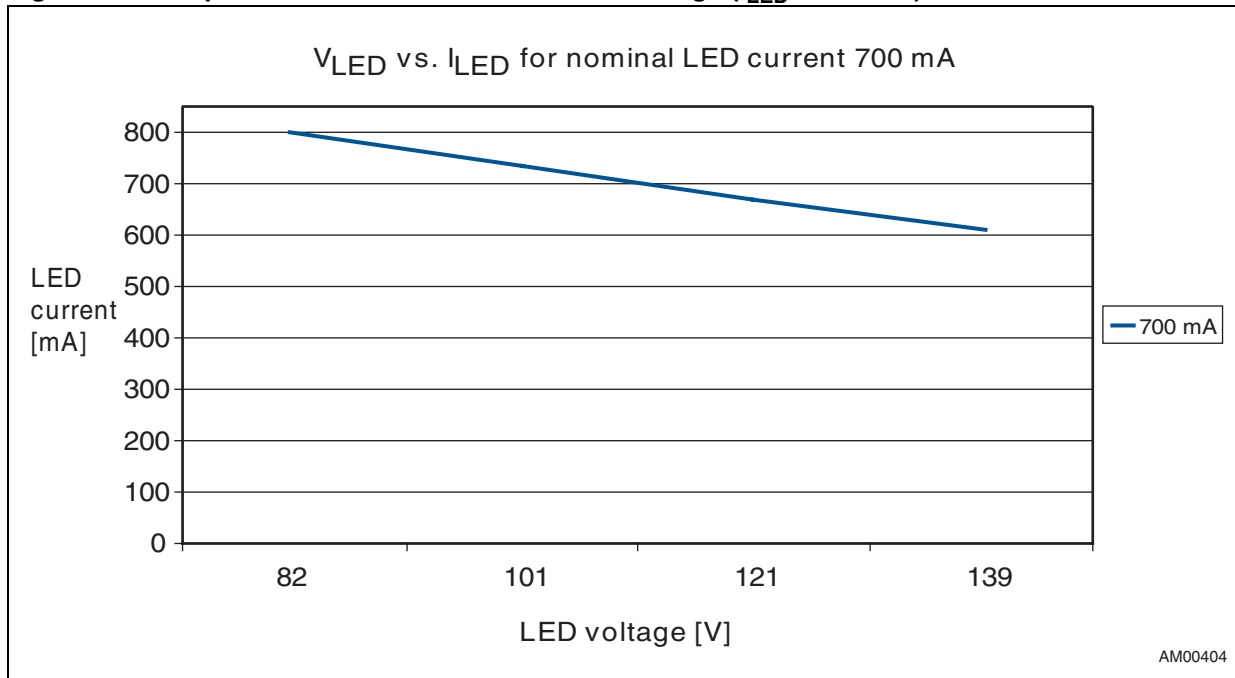

Figure 17 shows the output LED current waveform for the output LED current of 1000 mA. The current ripple is 433 mA and the switching frequency for the modified buck converter is 55 kHz. The input voltage was 230 VAC and 4 LEDs were used as the load (OSTAR LED LE UW E3B see [Section 11: References and related materials: 6](#)). The output LED current accuracy for the different LED voltages is shown in [Figure 18](#).

Figure 17. Output LED current waveform ($I_{LED} = 1000 \text{ mA}$)

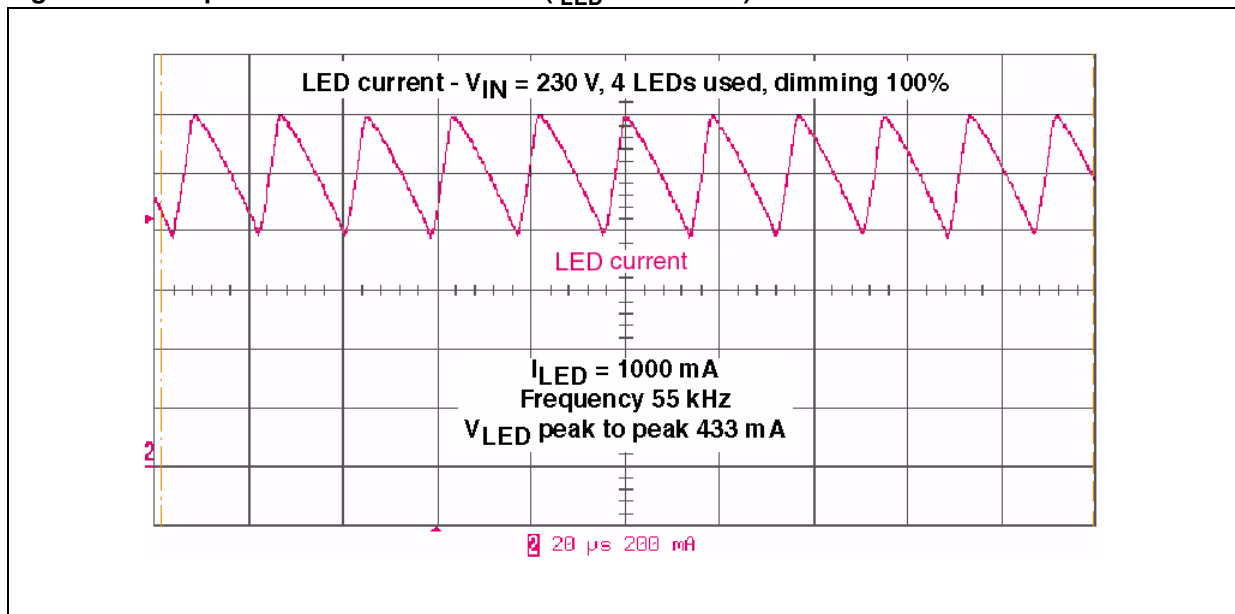
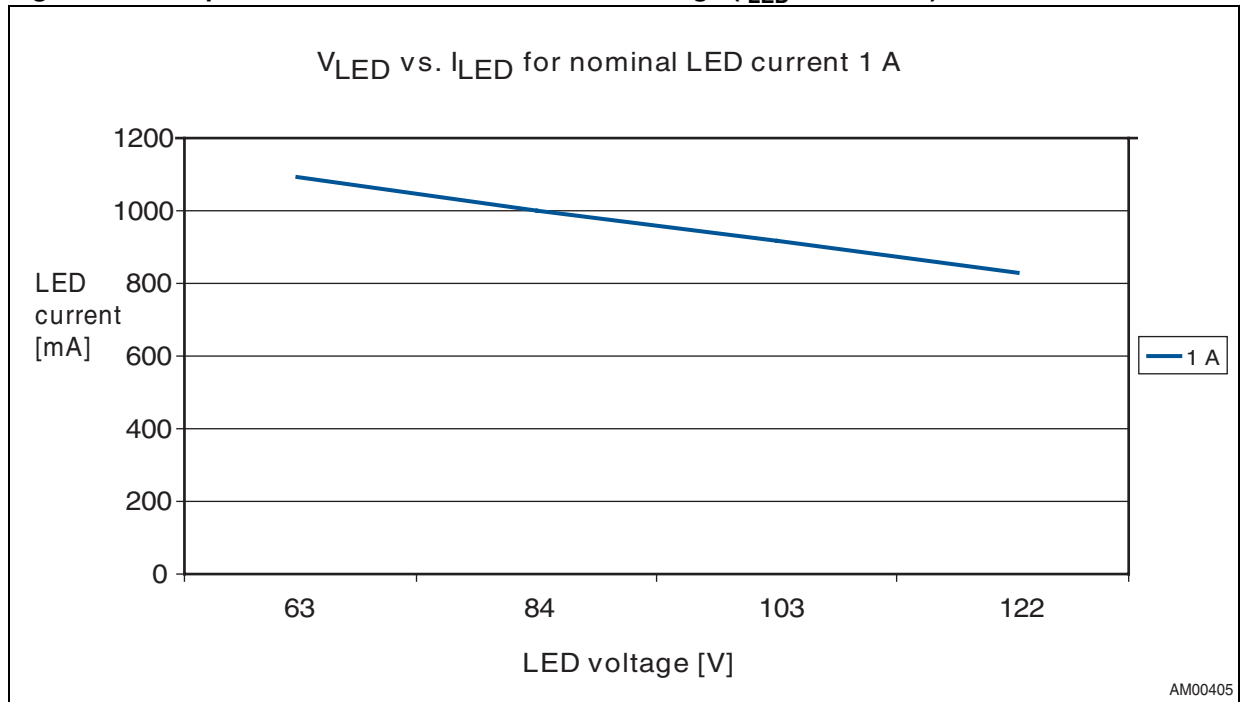

Figure 18. Output LED current for different LED voltage ($I_{LED} = 1000 \text{ mA}$)



9.2 Power MOSFET turn ON and OFF time

The power MOSFET turn ON and OFF time is shown in [Figure 19](#). Turn ON time is approximately 50 ns and turn OFF time is approximately 120 ns (OFF time is used in [Equation 13](#) in the appendix).

Figure 19. Power MOSFET turn ON and OFF measurement

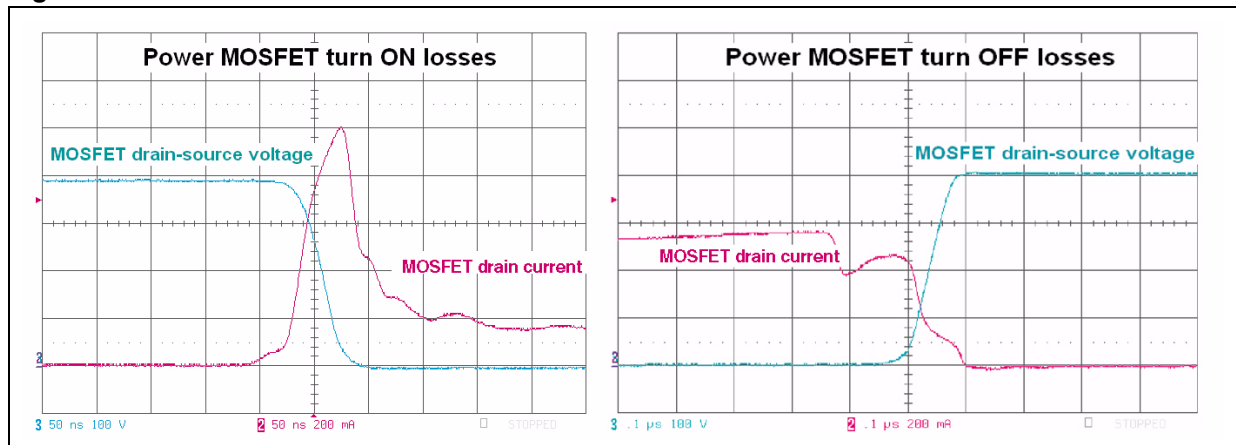

9.3 LED current ripple reduction

The output LED current ripple can be reduced by increasing the output capacitor size. For example, inductor current ripple is 400 mA for the 100 nF / 450 V output capacitor, as shown in [Figure 20](#). Thanks to the larger 470 nF capacitor used on the STEVAL-ILL013V1, the

output current ripple is reduced to 92 mA (see [Figure 13](#)). However, there are some limitations for the capacitors used in dimmable applications, as capacitors that are too large cause a decrease in dimming resolution (minimum duty cycle is limited). The 470 nF capacitor used on the STEVAL-ILL013V1 is a good compromise between lower output current ripple and good dimming resolution, as illustrated in [Figure 12](#).

Figure 20. LED current ripple for the 100 nF output capacitor

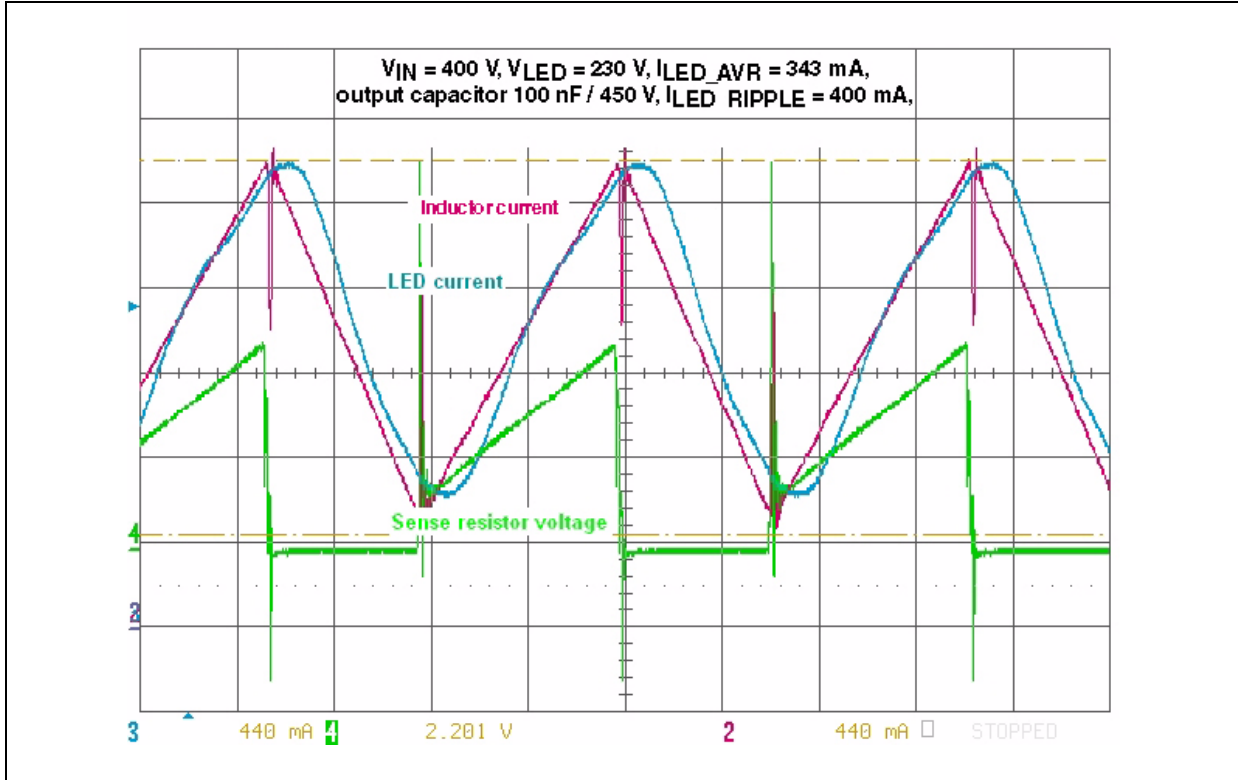

9.4 Standard EN61000-3-2 measurement

Figure 21. EN61000-3-2 analysis for LED current of 350 mA and V_{IN} from 85 V to 160 VAC

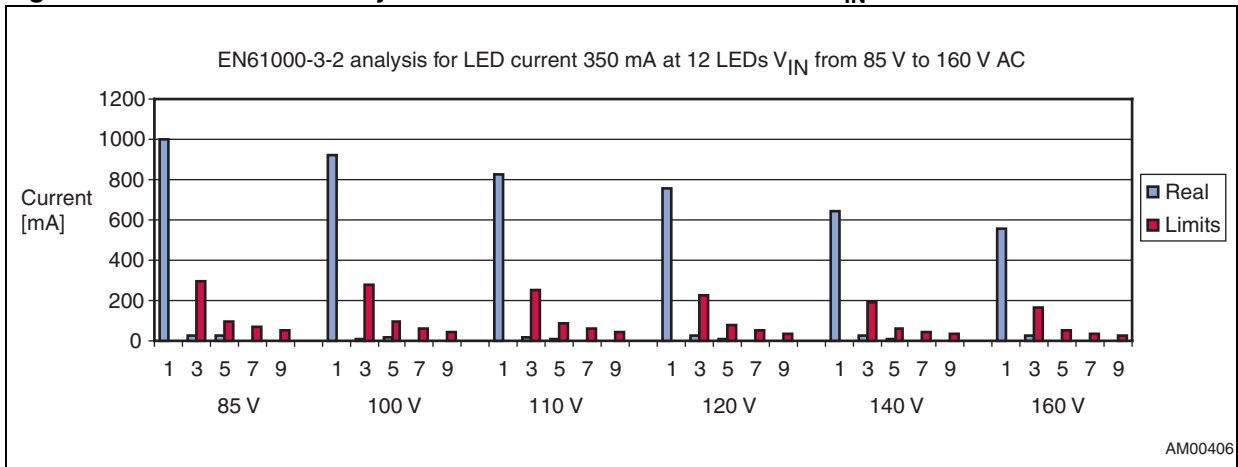

AM00406

Figure 22. EN61000-3-2 analysis for LED current of 350 mA and V_{IN} from 180 V to 265 VAC

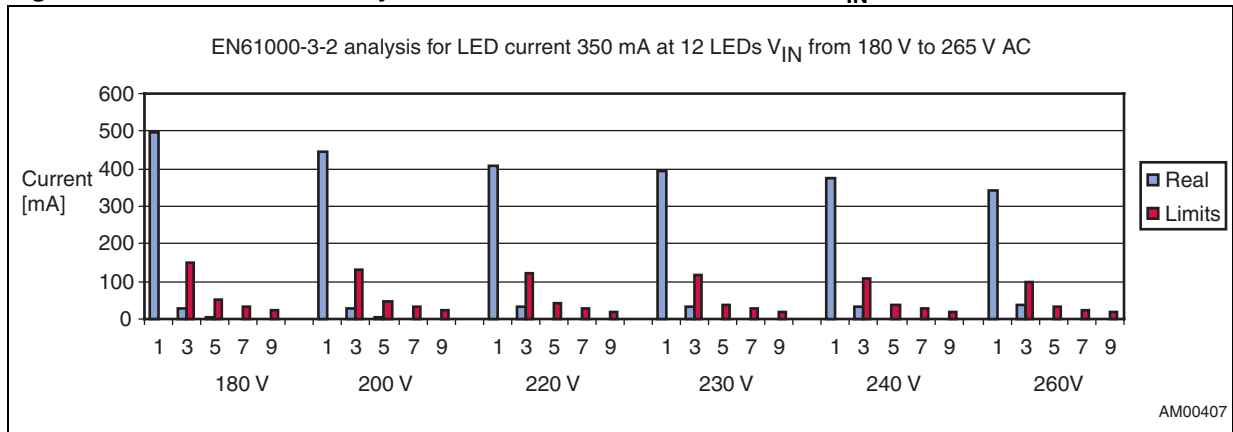

Figure 23. EN61000-3-2 analysis for LED current of 700 mA and V_{IN} from 85 V to 160 VAC

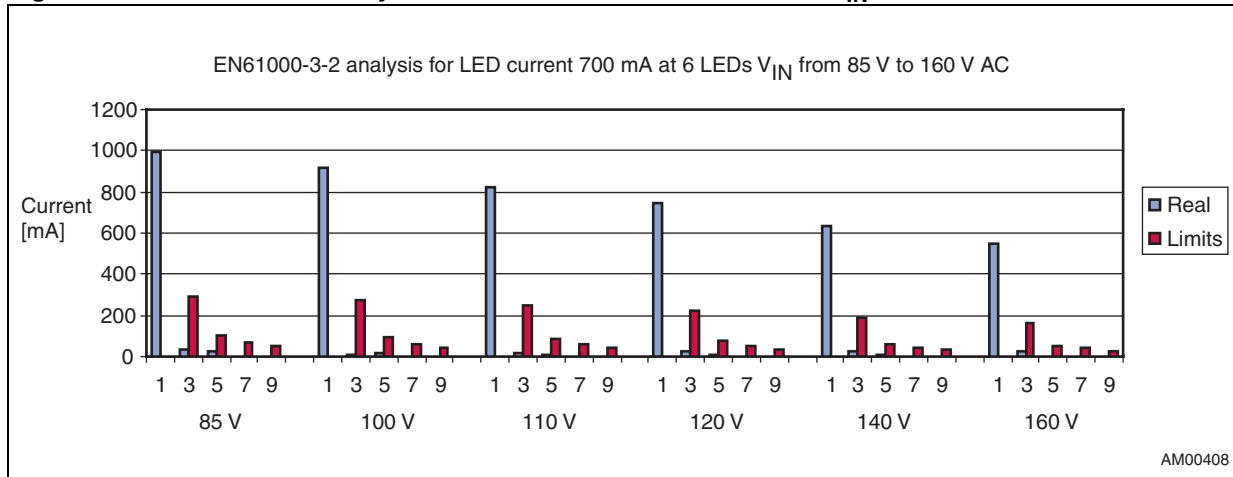

Figure 24. EN61000-3-2 analysis for LED current of 700 mA and V_{IN} from 180 V to 265 VAC

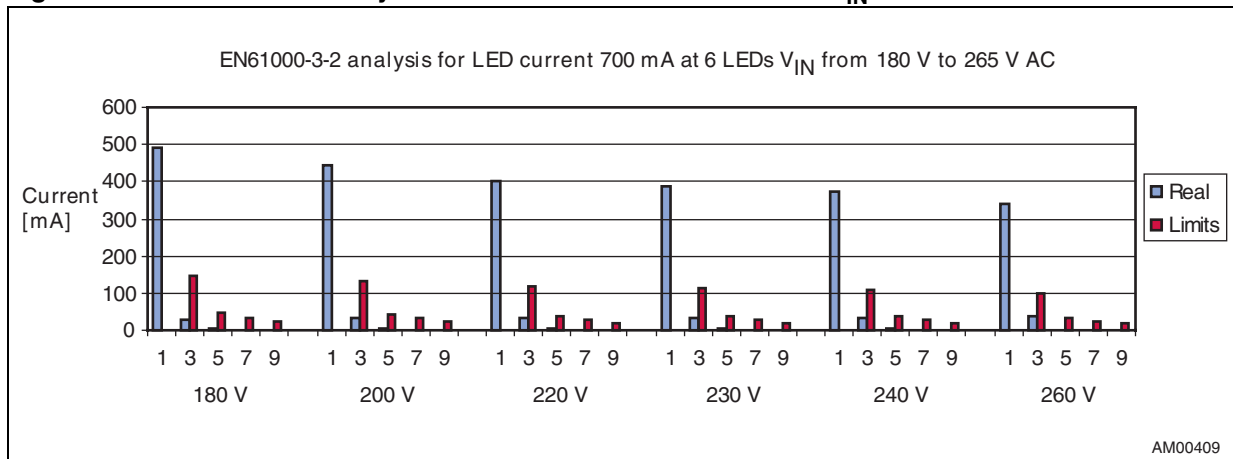

Figure 25. EN61000-3-2 analysis for LED current of 1000 mA and V_{IN} from 85 V to 160 VAC

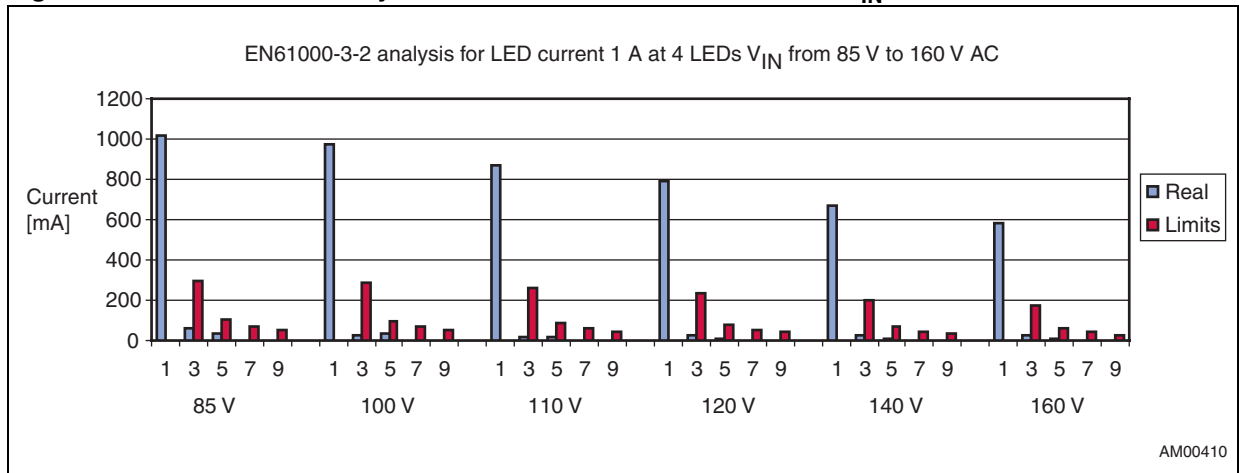
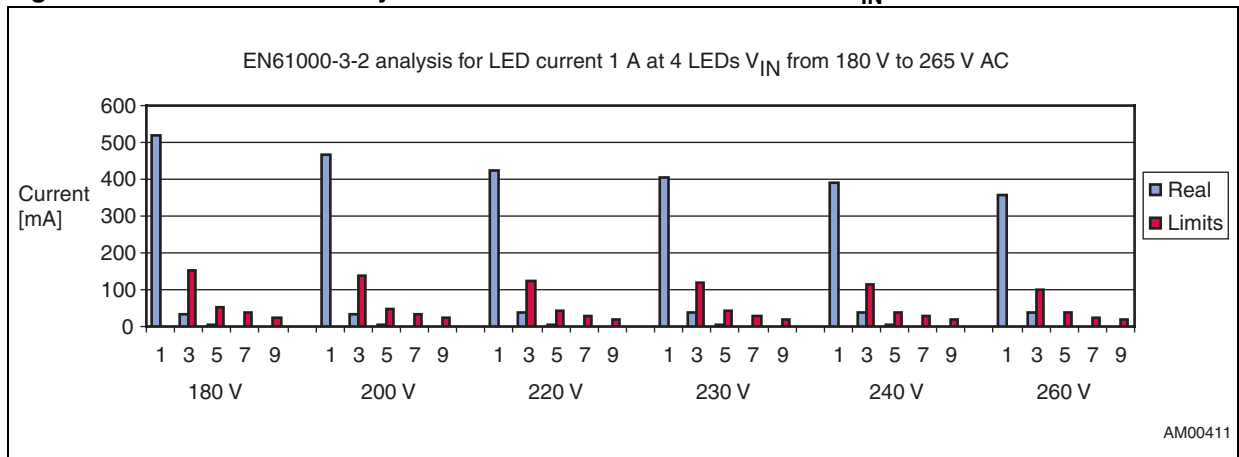

Figure 26. EN61000-3-2 analysis for LED current of 1000 mA and V_{IN} from 180 V to 265 VAC



9.5 EMI measurement (EN55015)

Figure 27. Average limit measurement from 150 kHz to 30 MHz ($I_{LED} = 350\text{ mA}$)

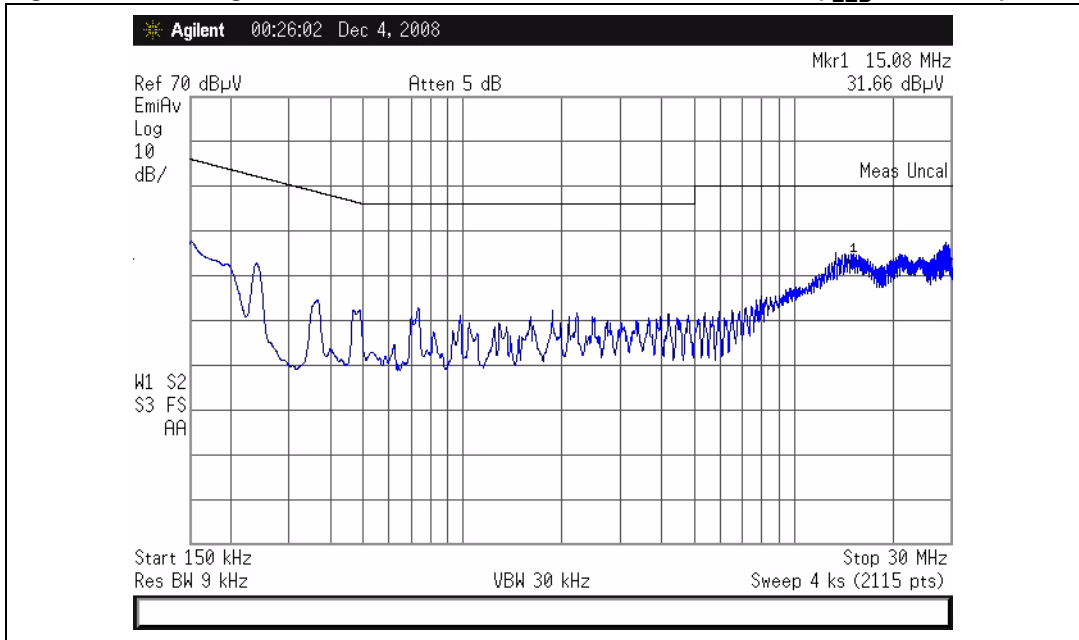

Figure 28. Quasi-peak limit measurement from 9 kHz to 150 kHz ($I_{LED} = 350\text{ mA}$)

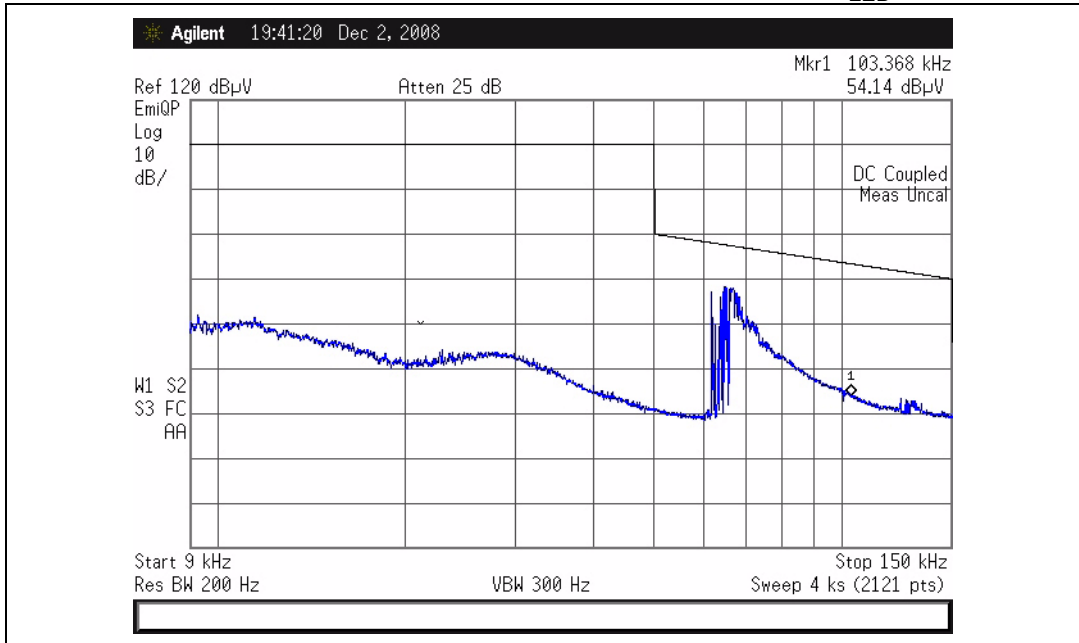

Figure 29. Quasi-peak limit measurement from 150 kHz to 30 MHz ($I_{LED} = 350\text{ mA}$)

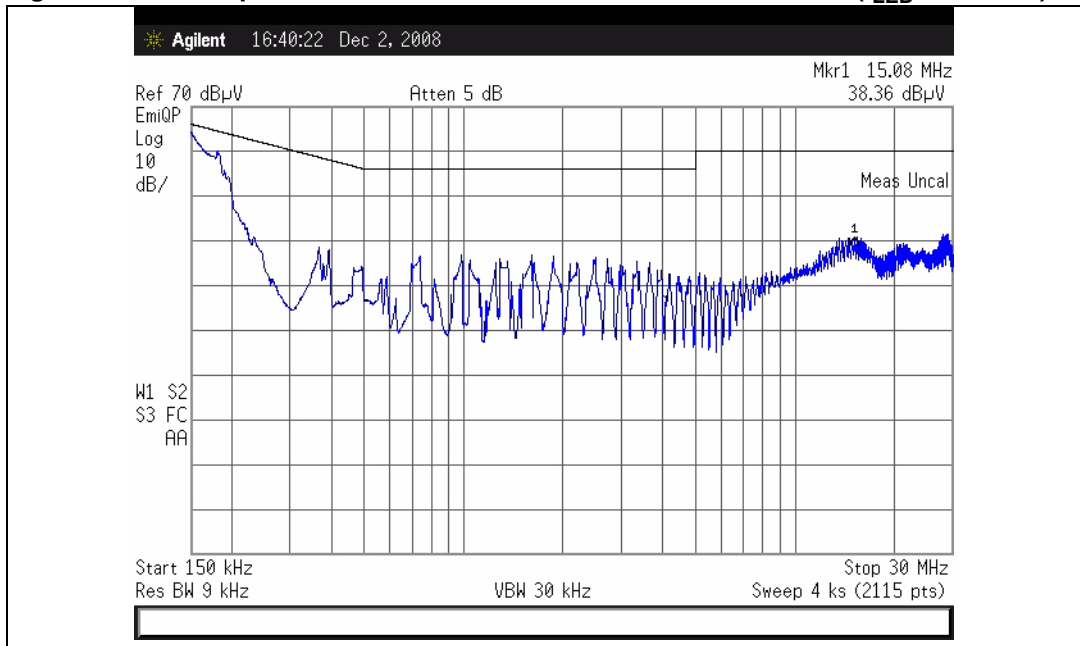

Figure 30. Average limit measurement from 150 kHz to 30 MHz ($I_{LED} = 700\text{ mA}$)

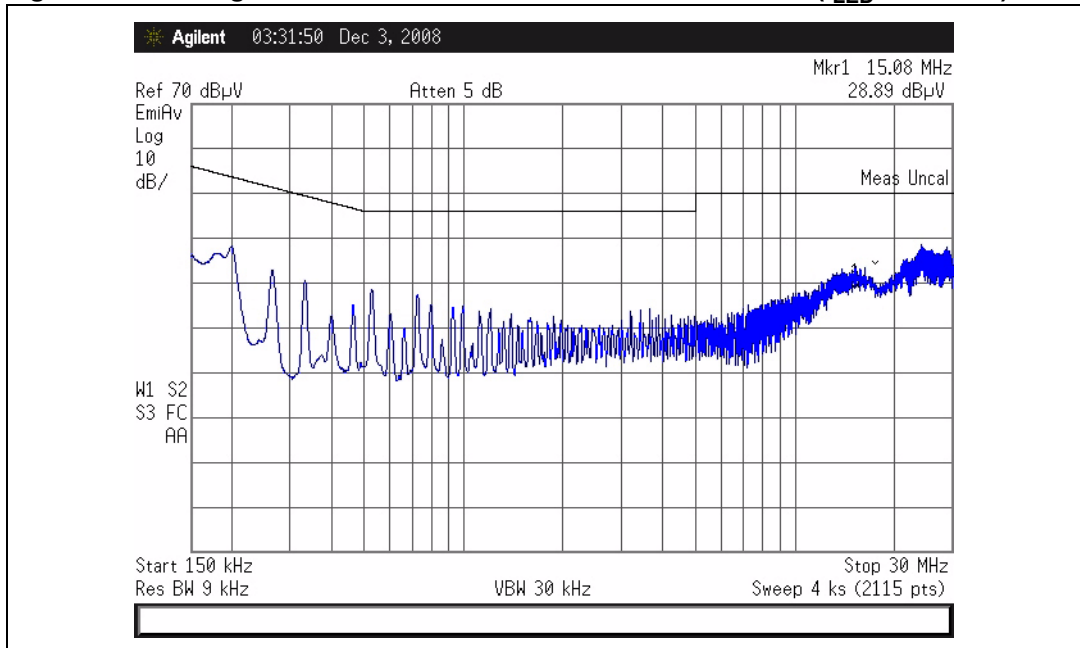

Figure 31. Quasi-peak limit measurement from 9 kHz to 150 kHz ($I_{LED} = 700\text{ mA}$)

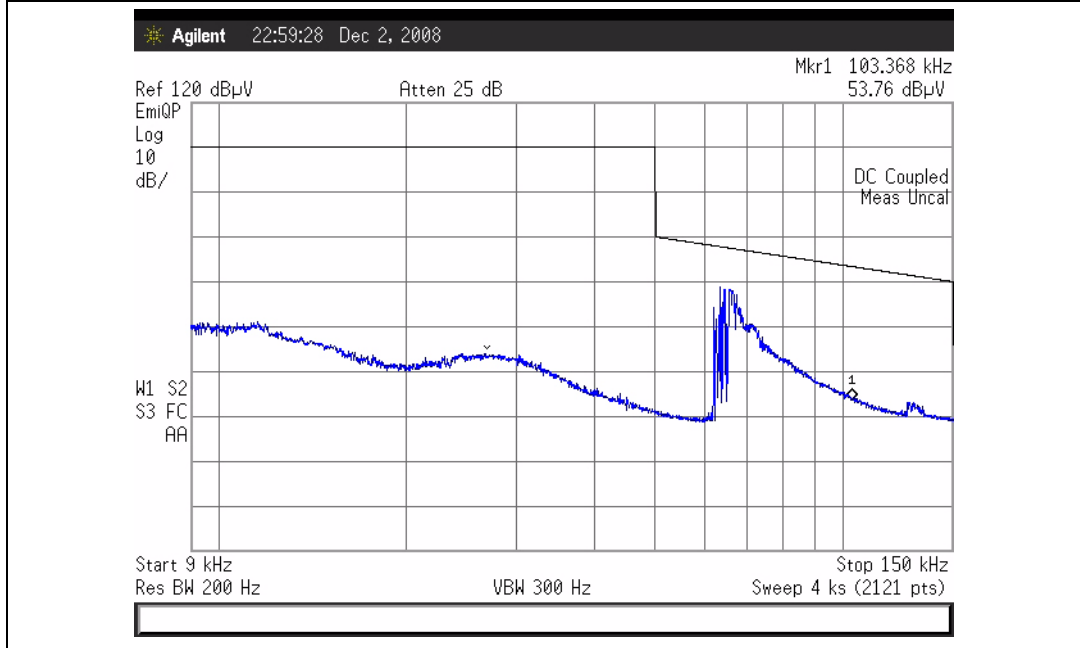

Figure 32. Quasi-peak limit measurement from 150 kHz to 30 MHz ($I_{LED} = 700\text{ mA}$)

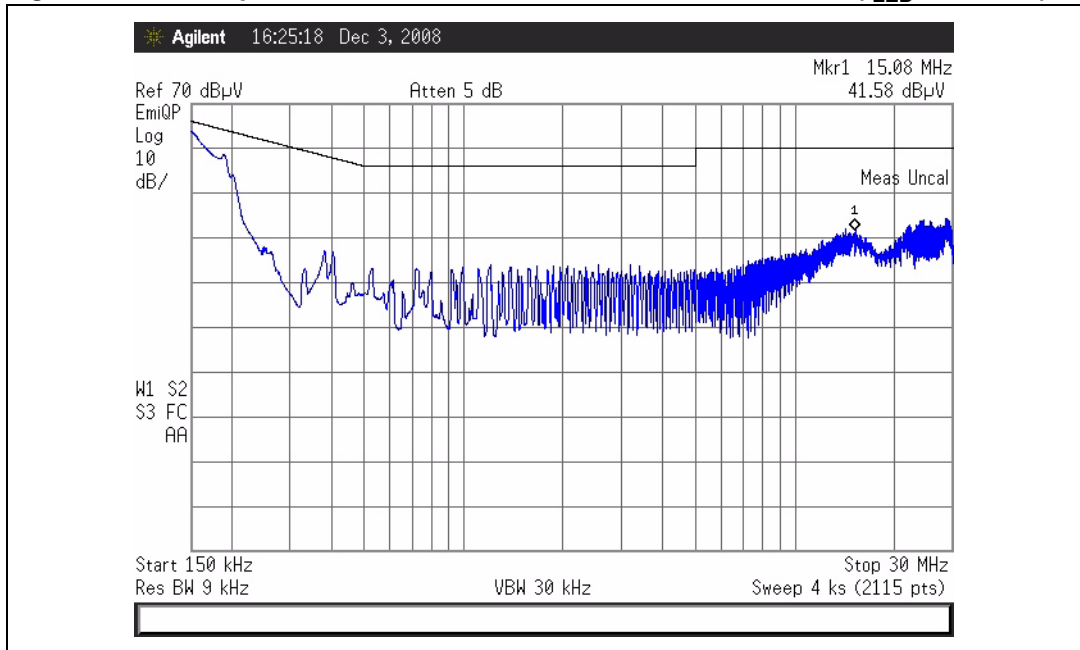

Figure 33. Average limit measurement from 150 kHz to 30 MHz ($I_{LED} = 1000\text{ mA}$)

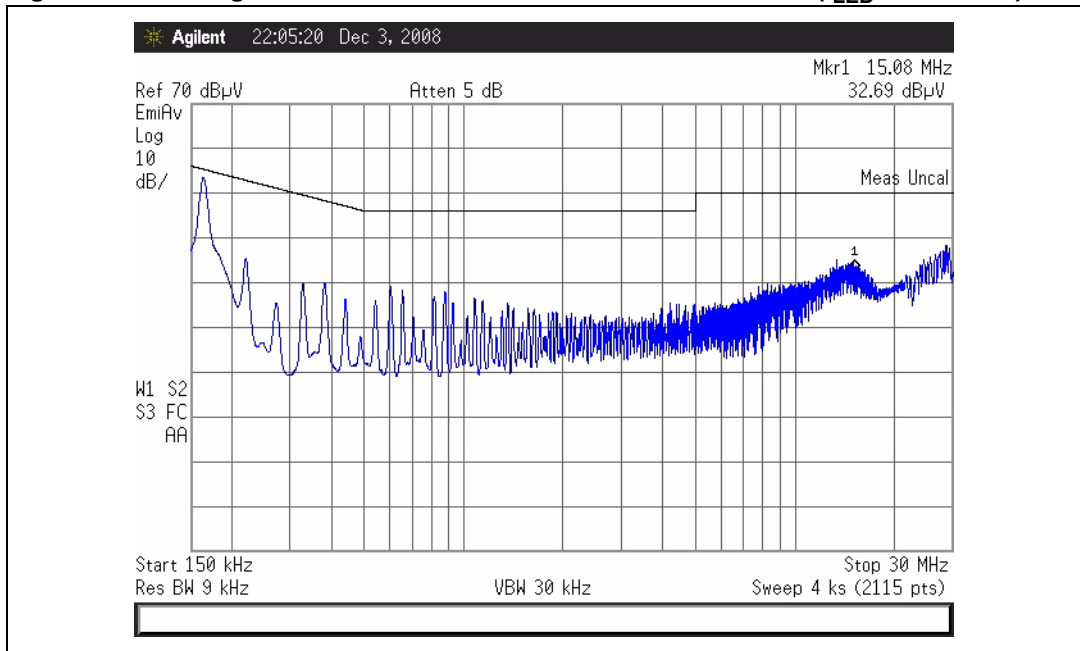

Figure 34. Quasi-peak limit measurement from 9 kHz to 150 kHz ($I_{LED} = 1000\text{ mA}$)

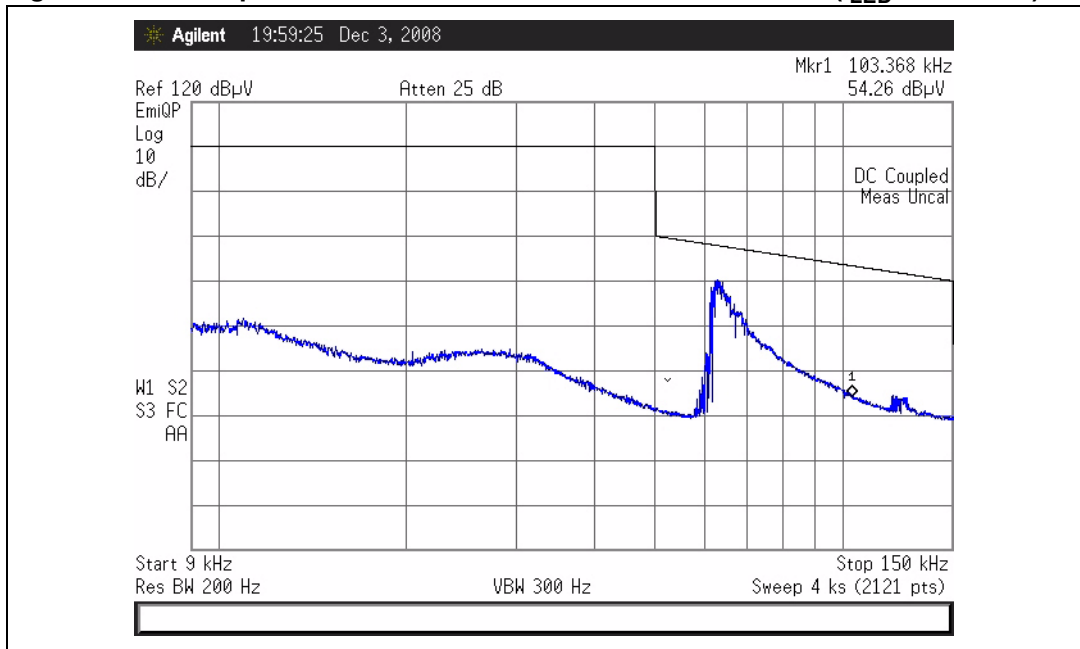

Figure 35. Quasi-peak limit measurement from 150 kHz to 30 MHz ($I_{LED} = 1000\text{ mA}$)

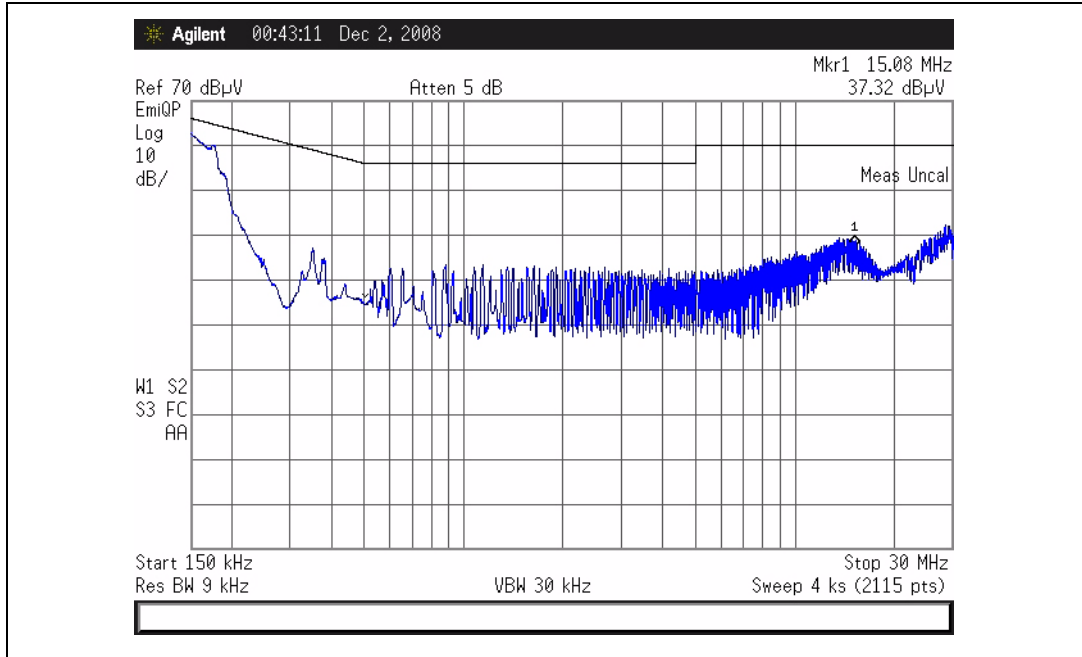

Figure 36. Average limit measurement from 150 kHz to 30 MHz ($I_{LED} = 0\text{ mA}$)

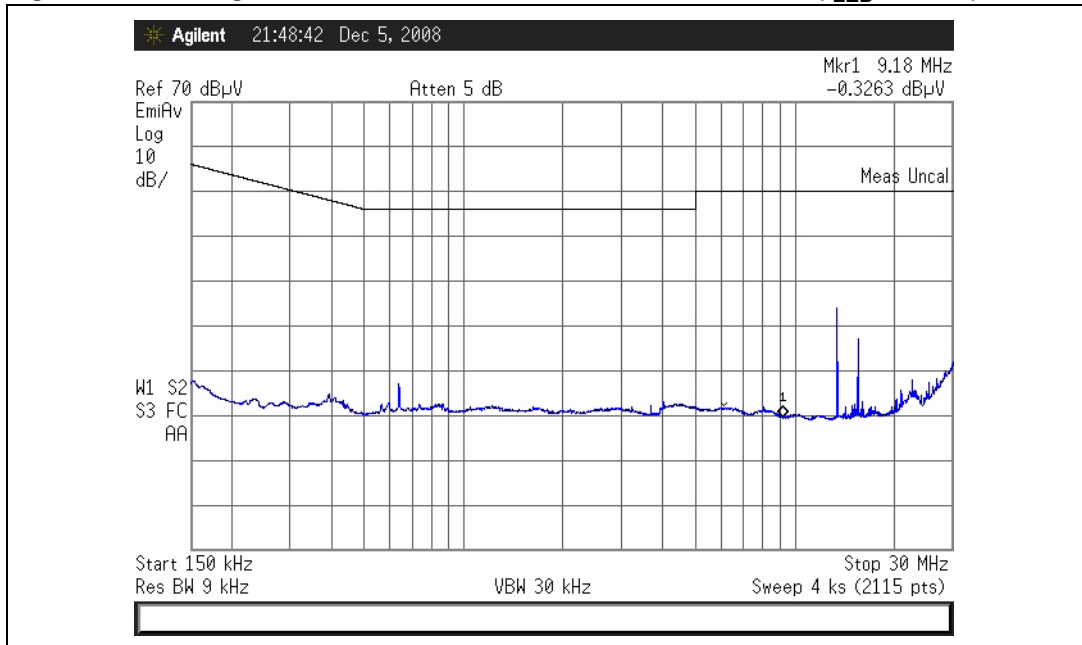

Figure 37. Quasi-peak limit measurement from 9 kHz to 150 kHz ($I_{LED} = 0 \text{ mA}$)

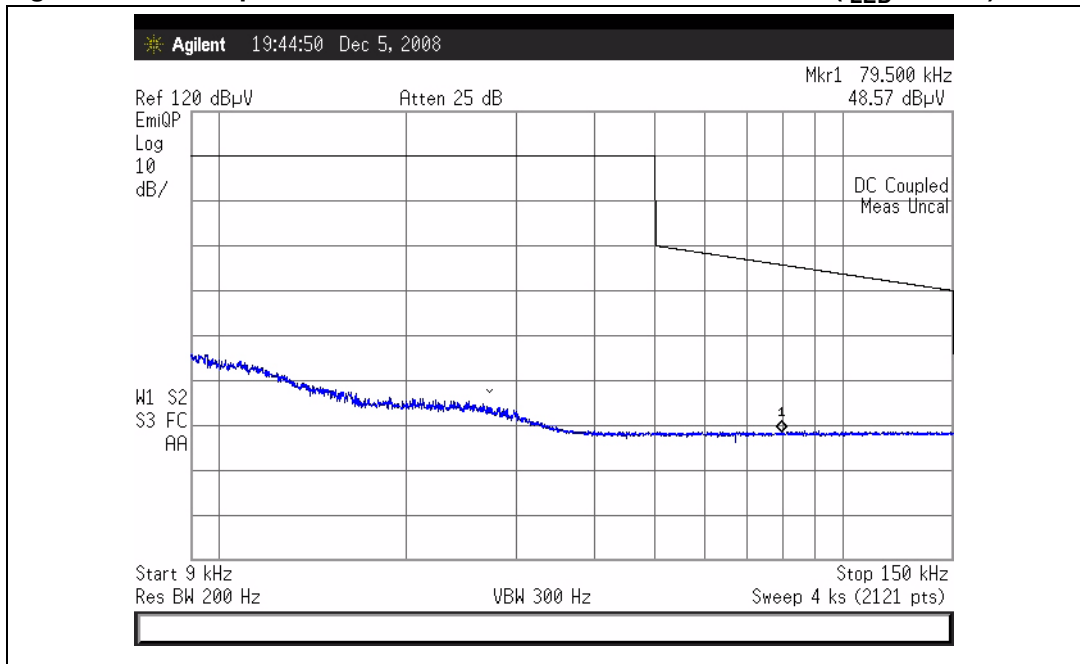
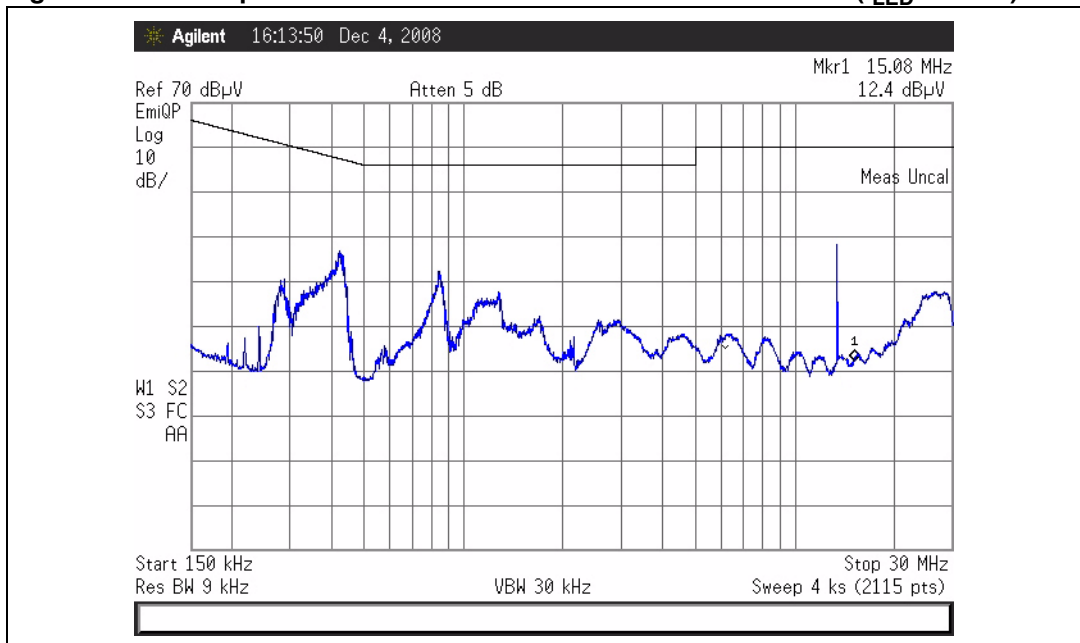

Figure 38. Quasi-peak limit measurement from 150 kHz to 30 MHz ($I_{LED} = 0 \text{ mA}$)



10 Design features

10.1 Proper startup circuit design

High PF boost converter design is described in the EVL6562A-TM-80W ([Section 11: References and related materials: 1.](#)) and this type of design typically includes a single electrolytic capacitor on the V_{CC} pin of the L6562A to ensure proper startup. The situation for the STEVAL-ILL013V1 is different, as this input capacitor also supplies the second L6562A driver, used for controlling the modified buck converter, and also provides a supply voltage for the PWM generator. Generally, this means that there is always some additional current discharging the input capacitor during startup, and therefore the high PF boost converter does not start properly if the low input AC voltage is applied to the board. This is due to there being insufficient energy in the input capacitor to guarantee proper startup. The waveforms which illustrate this situation are given in [Figure 41](#) (circuit without capacitor C110 and diode D104). As soon as the input voltage reaches the turn ON threshold, the L6562A starts operating and the input voltage on the V_{CC} pin is decreased. As soon as it reaches the turn OFF threshold, the capacitor is charged again and the L6562A stops operating. This behavior is repeated and so after a short period the output voltage should reach 400 V. However, this is not possible due to low energy in the input capacitor on the V_{CC} pin. This problem is solved by adding capacitor C110 and diode D104 to the original schematic, as shown in [Figure 39](#). Thanks to this configuration the input capacitor C107 on the V_{CC} pin is not discharged because it is supplying the PWM generator and second converter. Capacitor C110 is used to provide supply voltage to the PWM generator and the second converter. Capacitor C110 is charged via a capacitive supply source connected to the ZCD when the L6562A operates. The voltage on capacitor C110 is added to the voltage on capacitor C107 through diode D104, and as soon as the voltage on capacitor C110 also reaches the turn ON threshold, the L6562A starts operating continuously and the output voltage reaches 400 V, as shown in [Figure 40](#).

Figure 39. Proper startup circuit design

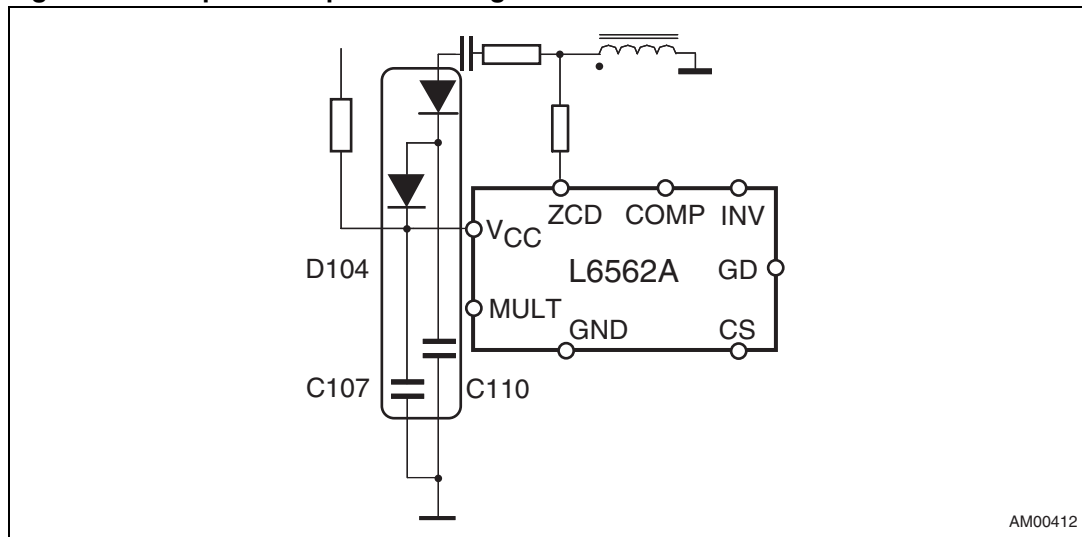

AM00412

Figure 40. Proper startup using diode D104 and capacitor C110

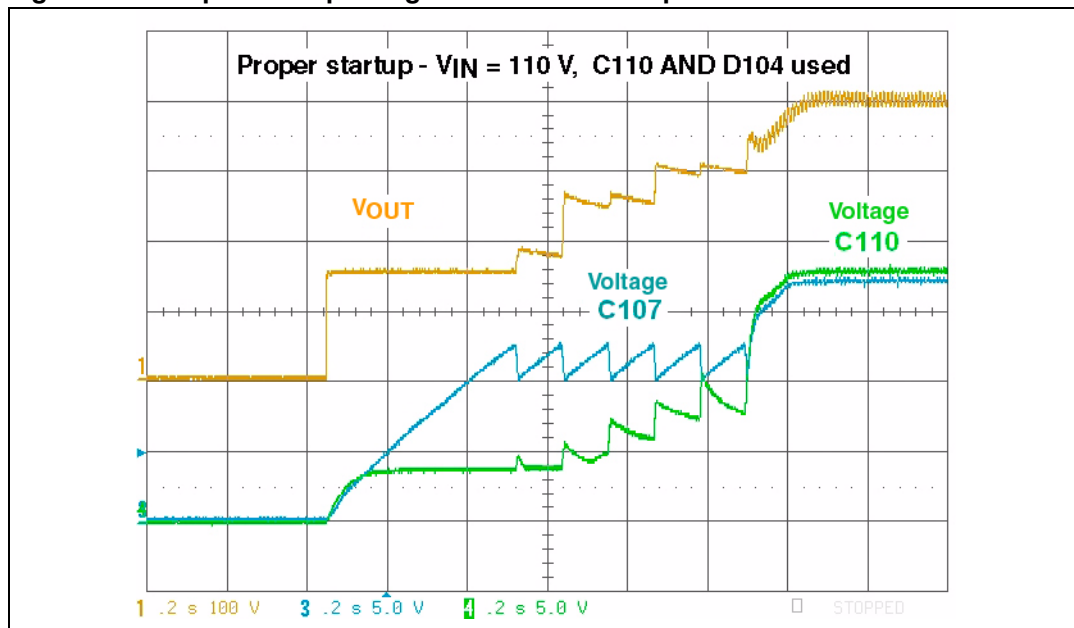
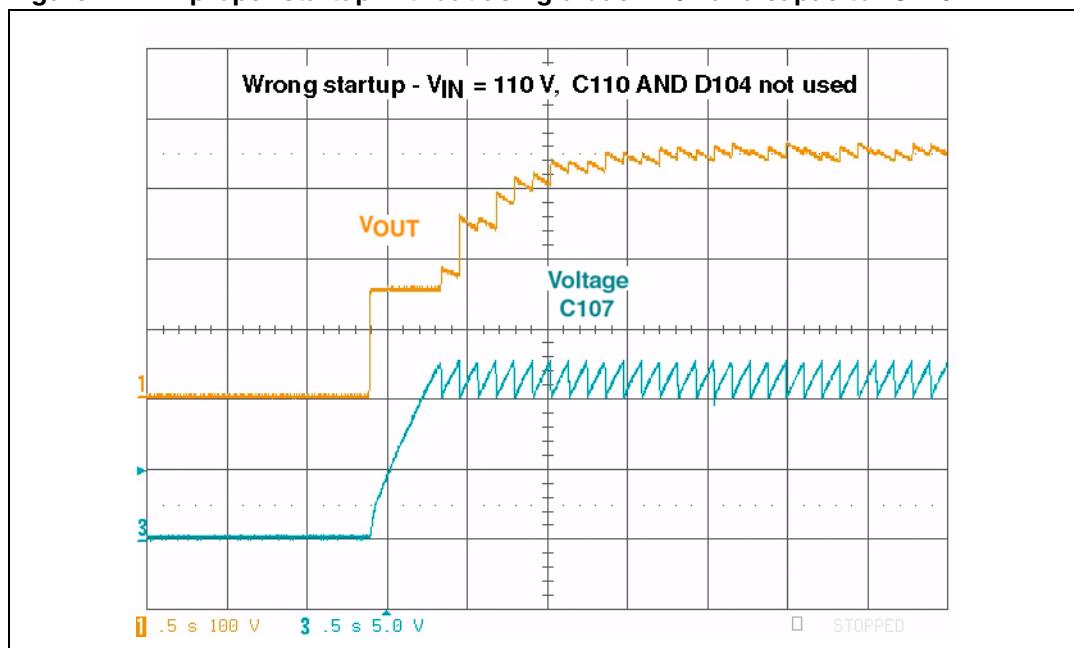

Figure 41. Improper startup without using diode D104 and capacitor C110



10.2 Zero dimming design implementation

During zero dimming (duty cycle is 0%) the high PF boost converter is in burst mode because there is zero load. During this mode, capacitors C107 and C110 are charged only in short pulses (C107 is also slightly charged via resistor from the input voltage, but it is not enough) and therefore do not have enough energy to also supply the PWM generator and the second L6562A controller used for the modified buck converter. The circuit shown in [Figure 42](#) allows brightness changes down to 0% without any problem, because if the

voltage on the emitter of Q102 is below the limit established by voltage divider R125 and R128 (upper limit set to 16.6 V) the transistor is opened and charges C110 and C107. Therefore, it is possible to change the brightness between 0% and 100% on the STEVAL-ILL013V1. The real measurement is shown in [Figure 43](#), and it is evident that the supply voltage on capacitor C110 is not below 12.5 V during no brightness.

Figure 42. Design improvement allowing zero dimming

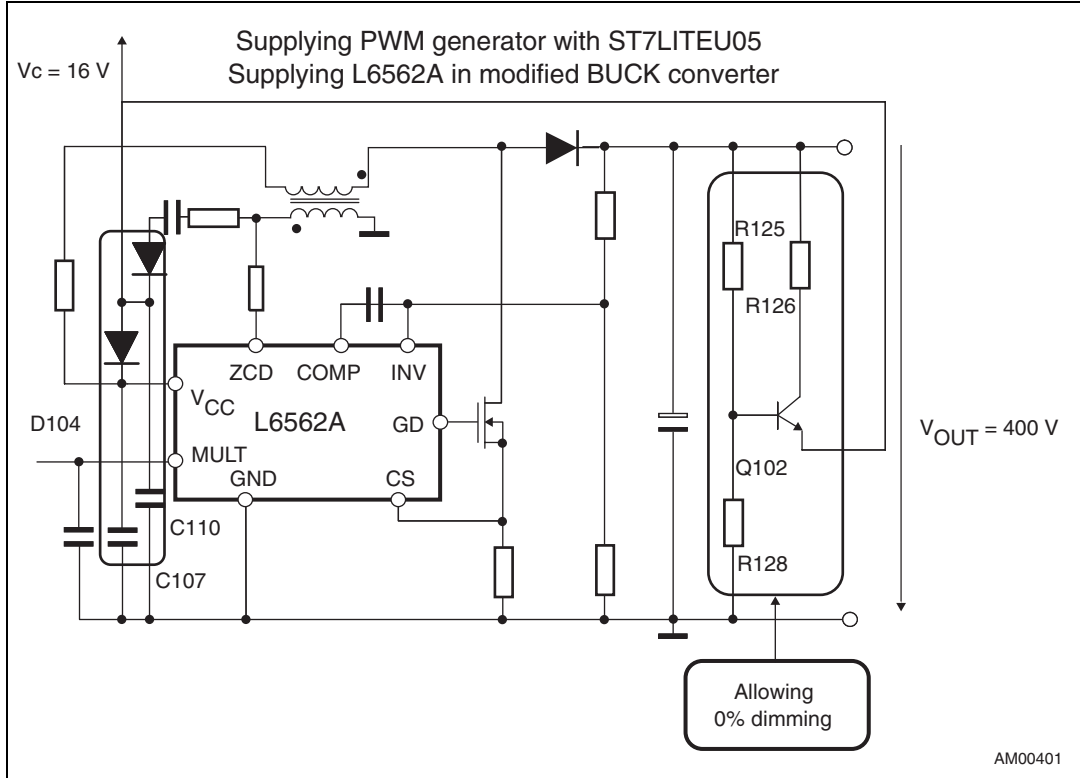
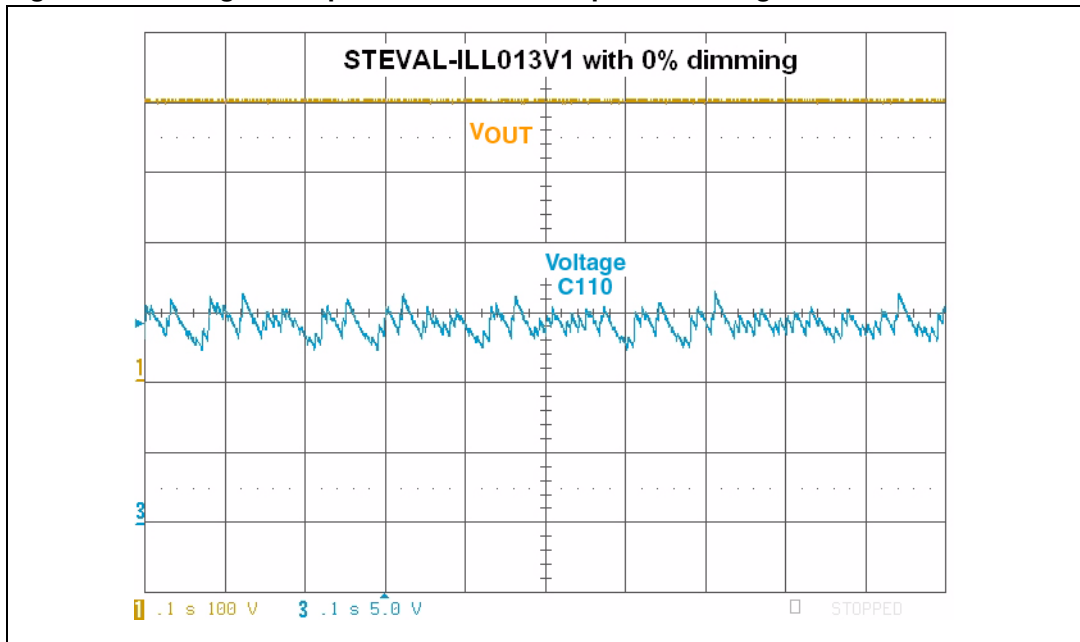

Figure 43. Voltage on capacitor C110 and output bus voltage of 400 V



11 References and related materials

1. STMicroelectronics, EVL6562A-TM-80W, 80 W high performance transition mode PFC evaluation board, data brief; see www.st.com
2. STMicroelectronics, AN2928, Modified buck converter for LED applications, application note; see www.st.com
3. STMicroelectronics, STF9NM50N, N-channel second generation MDmesh™ power MOSFET, datasheet; see www.st.com
4. STMicroelectronics, STPSC806D, 600 V power Schottky silicon carbide diode, datasheet; see www.st.com
5. EPCOS, B66317, Ferrites and accessories E25/13/7 (EF25) core and accessories, datasheet; see www.epcos.com
6. OSRAM, LE UW E3B, OSTAR Lighting with optics, datasheet; see www.osram-os.com.

Appendix A Design calculation

The aim of this section is to demonstrate how the components for the modified buck converter are calculated. Design calculation follows precisely the equations used in application note AN2928 ([Section 11: References and related materials: 2](#)). Therefore, please refer to this application note for more information.

A.1 Design specifications for a modified buck convertor

- $V_{IN} = 400 \text{ V}$
- $V_{LED} = 80 \text{ V}$
- $I_{AVR} = 1 \text{ A}$
- $I_{MAX} = 1.4 \text{ A}$
- $I_{MIN} = 0.6 \text{ A}$
- $f = 50 \text{ kHz}$
- $T_A = 30 \text{ }^\circ\text{C}$
- $T_{JMAX_MOSFET} = 70 \text{ }^\circ\text{C}$

Modified buck converter working with duty cycle (output LED current is 1 A):

Equation 1

$$D = \frac{V_{LED}}{V_{IN}} = \frac{80}{400} = 0.2$$

Calculated OFF time for selected switching frequency of 50 kHz is:

Equation 2

$$t_{OFF} = \frac{(1-D)}{f} = \frac{(1-0.2)}{50000} = 16\mu\text{s}$$

Now, the FOT network should be calculated. First, resistor R203 is selected:

$$R_{203} = 3900 \Omega$$

Two capacitors in parallel (C204 and C206) are used for the 1 A output LED current (jumper JP3 is connected) and their size is determined using the following equation:

Equation 3

$$C_{204} \parallel C_{206} = \frac{t_{OFF}}{2.1 \times R_{203}} = \frac{16 \times 10^{-6}}{2.1 \times 3900} = 1.95\text{nF}$$

Therefore the capacitors C204 and C206 have the following size:

$$C_{204} = 390 \text{ pF}$$

$$C_{206} = 1.5 \text{ nF}$$

Resistor R202 limits the charging current and should be in the following range:

Equation 4

$$\left[\frac{V_{GD_MAX} - V_{ZCD_CLAMP} - V_F}{I_{ZCD_MAX} + \frac{V_{ZCD_CLAMP}}{R_{203}}} \right] < R_{202} < R_{203} \times \left(\frac{V_{GD_MIN} - V_{ZCD_CLAMP} - V_F}{V_{ZCD_CLAMP}} \right)$$

Equation 5

$$\left[\frac{15 - 5.7 - 0.7}{0.01 + \left(\frac{5.7}{3900} \right)} \right] < R_{202} < 3900 \times \left(\frac{9.8 - 5.7 - 0.7}{5.7} \right)$$

Equation 6

$$750 < R_{202} < 2326$$

A 1 kΩ resistor is chosen for R202.

Capacitor C203 should be lower than 1.25 nF, and therefore a value of 220 pF was chosen:

Equation 7

$$C_{203} < (C_{204} \parallel C_{206}) \frac{V_{ZCD_CLAMP}}{(V_{GD_CMAX} - V_{ZCD_CLAMP} - V_F)} = 1.89 \times 10^{-9} \frac{5.7}{15 - 5.7 - 0.7} = 1.25 \text{ nF}$$

$$C_{203} = 220 \text{ pF}$$

Inductor size is calculated using following equation:

Equation 8

$$L = \frac{V_{LED} \times t_{OFF}}{2 \times (I_{MAX} - I_{AVR})} = \frac{80 \times 16 \times 10^{-6}}{2 \times (1.4 - 1)} = 1.6 \text{ mH}$$

Two sense resistors are connected in parallel and their size is calculated:

Equation 9

$$R_{204} \parallel R_{206} = \frac{V_{CS}}{I_{MAX}} = \frac{1.08}{1.04} = 0.77 \Omega$$

The output LED current of 1 A was precisely set by adjusting resistors R204 and R206, and therefore their optimal resistance values are 1.5 Ω and 2.2 Ω

$$R_{204} = 1.5 \Omega$$

$$R_{206} = 2.2 \Omega$$

In the next step the power MOSFET and its heat sink are calculated. The power MOSFET RMS current is derived using the following equation:

Equation 10

$$I_{RMS}^2 = D \times \left[I_{AVR}^2 + \frac{I_{PP}^2}{12} \right] = 0.2 \left[1 + \frac{0.8^2}{12} \right] = 0.21$$

Power MOSFET conduction loss is:

Equation 11

$$P_{CON} = I_{RMS}^2 \times R_{DS(ON)(70^\circ C)} = 0.21 \times 0.756 = 0.159W$$

Where the power MOSFET chosen is the STF9NM50N (see datasheet [Section 11: References and related materials: 3.](#)) and its $R_{DS(on)}$ for 70 °C is:

Equation 12

$$R_{DS(ON)(^\circ C)} = R_{DS(ON)(^\circ C)} \times 1.35 = 0.56 \times 1.35 = 0.756\Omega$$

Power MOSFET switching losses can be approximately calculated (turn OFF time was measured 120 ns - see [Figure 19](#)):

Equation 13

$$P_{SW} = \frac{V_{IN} \times I_{MAX} \times t_{OFF_SW} \times f}{2} = \frac{400 \times 1.4 \times 120 \times 10^{-9} \times 50 \times 10^3}{2} = 1.68W$$

The total power loss on the power MOSFET is 1.839 W, so the heat sink can be calculated from following equation:

Equation 14

$$P_{TOT} = \frac{T_{JMAX_MOSFET} - T_A}{R_{thJC} + R_{thCH} + R_{thHA}}$$

And maximum heat sink-to-ambient resistance is:

Equation 15

$$R_{thHA} < \frac{T_{JMAX_MOSFET} - T_A}{P_{TOT}} - R_{thJC} - R_{thCH} = \frac{70 - 30}{1.839} - 5 - 0.5 = 16.25^\circ C / W$$

The heat sink used in the power MOSFET on the STEVAL-ILL013V1 has a thermal resistance of 13.5 °C / W, and therefore this heat sink is optimized for this design.

The last power component remaining to be calculated is the power diode. The diode conducts during the OFF time, and therefore its average current is:

Equation 16

$$I_{AVR_D} = (1 - D) \times \frac{I_{MAX} + I_{MIN}}{2} = (1 - 0.2) \times \frac{1.4 + 0.6}{2} = 0.8A$$

Power loss on the STPSC806D diode is:

Equation 17

$$P_{\text{LOSS_D}} = I_{\text{AVR_D}} \times V_F = 0.8 \times 0.7 = 0.56 \text{ W}$$

where forward diode voltage was found for the average diode current 0.8 A in the datasheet (see datasheet [Section 11: References and related materials: 4.](#)).

Calculated junction diode temperature without using heat sink is:

Equation 18

$$T_J = P_{\text{LOSS_D}} \times (R_{\text{thJC}} + R_{\text{thCA}}) + T_A = 0.56 \times (2.4 + 60) + 30 = 65^\circ \text{ C}$$

Junction-to-case thermal resistance is available in the datasheet for the STPSC806D and case-to-ambient temperature is determined by the device package used. In this case, the TO-220 package is used and its thermal resistance is typically 60 °C / W.

Calculated junction diode temperature without using a heat sink is much lower than the maximum junction temperature for the STPSC806D, and therefore this diode is suitable for the design.

One of the most important things to consider is proper inductor design. The inductor size was calculated in [Equation 8](#), but generally the inductor size by itself is not enough to ensure proper inductor design and therefore several additional equations are used for completing overall inductor construction.

First, the inductor core size must be selected and for this selection it is very helpful to calculate the minimum area product using application parameters. Minimum required core area product (AP), where the flux swing is limited by core saturation is:

Equation 19

$$AP_{\text{MIN}} = \left(\frac{L \times I_{\text{PEAK}} \times I_{\text{RMS}}}{B_{\text{MAX}} \times Cl} \right)^{\frac{4}{3}} = \left(\frac{1.6 \times 10^{-3} \times 1.4 \times 1}{0.3 \times 420 \times 0.5 \times 10^{-4}} \right)^{\frac{4}{3}} = 0.2518 \text{ cm}^4$$

where the constant is $Cl = J_{\text{MAX}} \times C_R \times 10^{-4} = 420 \times 0.5 \times 10^{-4}$.

The inductor core E25 from EPCOS was selected. The minimum core cross section is 51.5 mm² and the winding cross section is 61 mm² (see datasheet [Section 11: References and related materials: 5.](#)) and the calculated product area is:

Equation 20

$$AP = A_N \times A_{\text{MIN}} = 61 \times 51.5 = 0, 31415 \text{ cm}^4$$

The calculated product area is bigger than the minimum required product area, and therefore the inductor core E25 can be used.

The number of turns for the inductor is:

Equation 21

$$N = \sqrt{\frac{L}{A_L}} = \sqrt{\frac{1.6 \times 10^{-3}}{54.22 \times 10^{-9}}} = 172$$

where the inductance factor AL for the E25 core and 2 mm gap is calculated:

Equation 22

$$A_L = K_1 \times \frac{1}{K_2 \sqrt{s}} = 90 \times \frac{1}{-0.73 \sqrt{2}} = 54.22 \text{ nH}$$

$K_1 = 70$ (see datasheet [Section 11: References and related materials: 5.](#))

$K_2 = -0.73$ (see datasheet [Section 11: References and related materials: 5.](#))

$s = \text{E25 core air gap [mm]}$.

The last step to complete the inductor design is to calculate the wire diameter.

Maximum inductor power dissipation is:

Equation 23

$$P_{\text{MAX_LOSS}} = \frac{T_{\text{MAX}} - T_A}{R_T} = \frac{70 - 30}{40} = 1 \text{ W}$$

The wire resistance on the inductor is (copper wire with diameter of 0.28 mm is chosen):

Equation 24

$$R = \rho \times \frac{l}{s} = \rho \times \frac{l_N \times N}{\pi \times d} = 1.76 \times 10^{-6} \times \frac{5 \times 172}{3.14 \times 0.028} = 17.2 \text{ m}\Omega$$

where average turn length l_N is written in the core datasheet (see datasheet [Section 11: References and related materials 5.](#)).

The power dissipation on the wire is:

Equation 25

$$P_{\text{WIRE}} = R \times I_{\text{AVR}}^2 = 17.2 \times 10^{-3} \times 1^2 = 17.2 \text{ mW}$$

The power loss in the wire is much lower than the maximum power loss in the inductor, and so a wire with a diameter of 0.28 mm is suitable for this inductor.

12 Revision history

Table 4. Document revision history

Date	Revision	Changes
15-May-2009	1	Initial release.
10-Aug-2009	2	Document reformatted, corrected typing error in Figure 7 , added note below Table 3 .

Please Read Carefully:

Information in this document is provided solely in connection with ST products. STMicroelectronics NV and its subsidiaries ("ST") reserve the right to make changes, corrections, modifications or improvements, to this document, and the products and services described herein at any time, without notice.

All ST products are sold pursuant to ST's terms and conditions of sale.

Purchasers are solely responsible for the choice, selection and use of the ST products and services described herein, and ST assumes no liability whatsoever relating to the choice, selection or use of the ST products and services described herein.

No license, express or implied, by estoppel or otherwise, to any intellectual property rights is granted under this document. If any part of this document refers to any third party products or services it shall not be deemed a license grant by ST for the use of such third party products or services, or any intellectual property contained therein or considered as a warranty covering the use in any manner whatsoever of such third party products or services or any intellectual property contained therein.

UNLESS OTHERWISE SET FORTH IN ST'S TERMS AND CONDITIONS OF SALE ST DISCLAIMS ANY EXPRESS OR IMPLIED WARRANTY WITH RESPECT TO THE USE AND/OR SALE OF ST PRODUCTS INCLUDING WITHOUT LIMITATION IMPLIED WARRANTIES OF MERCHANTABILITY, FITNESS FOR A PARTICULAR PURPOSE (AND THEIR EQUIVALENTS UNDER THE LAWS OF ANY JURISDICTION), OR INFRINGEMENT OF ANY PATENT, COPYRIGHT OR OTHER INTELLECTUAL PROPERTY RIGHT.

UNLESS EXPRESSLY APPROVED IN WRITING BY AN AUTHORIZED ST REPRESENTATIVE, ST PRODUCTS ARE NOT RECOMMENDED, AUTHORIZED OR WARRANTED FOR USE IN MILITARY, AIR CRAFT, SPACE, LIFE SAVING, OR LIFE SUSTAINING APPLICATIONS, NOR IN PRODUCTS OR SYSTEMS WHERE FAILURE OR MALFUNCTION MAY RESULT IN PERSONAL INJURY, DEATH, OR SEVERE PROPERTY OR ENVIRONMENTAL DAMAGE. ST PRODUCTS WHICH ARE NOT SPECIFIED AS "AUTOMOTIVE GRADE" MAY ONLY BE USED IN AUTOMOTIVE APPLICATIONS AT USER'S OWN RISK.

Resale of ST products with provisions different from the statements and/or technical features set forth in this document shall immediately void any warranty granted by ST for the ST product or service described herein and shall not create or extend in any manner whatsoever, any liability of ST.

ST and the ST logo are trademarks or registered trademarks of ST in various countries.

Information in this document supersedes and replaces all information previously supplied.

The ST logo is a registered trademark of STMicroelectronics. All other names are the property of their respective owners.

© 2009 STMicroelectronics - All rights reserved

STMicroelectronics group of companies

Australia - Belgium - Brazil - Canada - China - Czech Republic - Finland - France - Germany - Hong Kong - India - Israel - Italy - Japan - Malaysia - Malta - Morocco - Philippines - Singapore - Spain - Sweden - Switzerland - United Kingdom - United States of America

www.st.com