

AUDÉO

personal communication assistant

User Guide



PHONAK

CE
0459

Contents

Welcome	3
<hr/>	
Description	4
<hr/>	
Preparation	6
Replacing the battery	6
Identifying left and right Audéo	9
Inserting Audéo with Fidelity Sound Port and Dome into your ear	10
<hr/>	
Operation	14
Switching ON/OFF	14
Fine tuning Audéo	15
Remote control (optional)	16
<hr/>	
Maintenance	20
Microphone Protector	20
Important points	22
<hr/>	
Warning	24
<hr/>	
Service and Warranty	25
<hr/>	
Phonak distributors worldwide	26
<hr/>	

Welcome

Congratulations on choosing Audéo Personal Communication Assistant, the most sophisticated communication device currently available. It uses the latest advances in digital sound processing to automatically adjust to your listening needs. Audéo Personal Communication Assistant provides the highest sound quality, speech understanding and listening comfort in all your personal communication situations. Its modern design is inconspicuous when worn and ensures optimal placement on the ear for best performance.

Audéo is a quality product developed by the Swiss company Phonak, a world leader in communication technology, innovation and reliability. Please read this manual carefully to benefit from all the features of your new Personal Communication Assistant. With proper care, Audéo will support your understanding for many years.

If you want additional information about Audéo, please visit the Audéo website www.audeoworld.com

Phonak – your partner for good hearing!

Description

Audéo with Fidelity Sound Port

- ① Microphone inputs with Microphone Protector
- ② Battery compartment with ON/OFF switch
- ③ Fidelity Sound Port
- ④ Retention (optional)
- ⑤ Dome

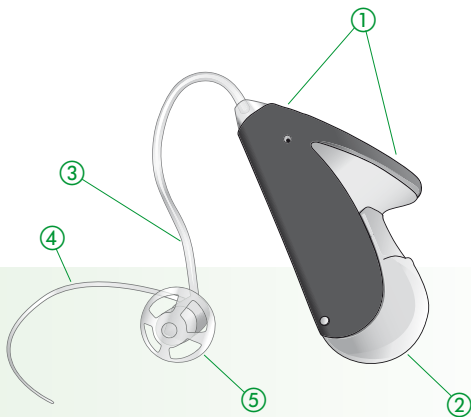

Protective case

A special protective case is provided to securely store your Personal Communication Assistants (PCAs) and batteries.

Store your Audéo PCAs in their protective case when not in use and leave the battery compartment in the OFF position (as described on page 14) to allow any moisture to evaporate. Remove the batteries if you will not be using your PCAs for any length of time.

- ① Left Audéo
- ② Right Audéo
- ③ Spare batteries

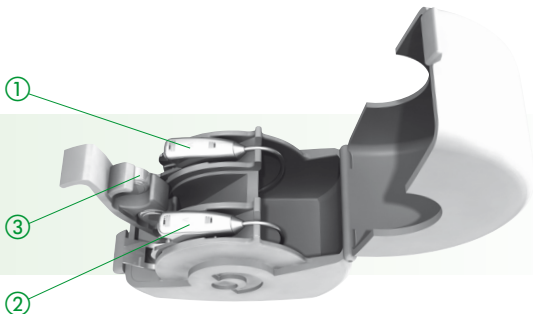

Preparation

Replacing the battery

Using the nail grip, open the battery compartment completely and remove the old battery.

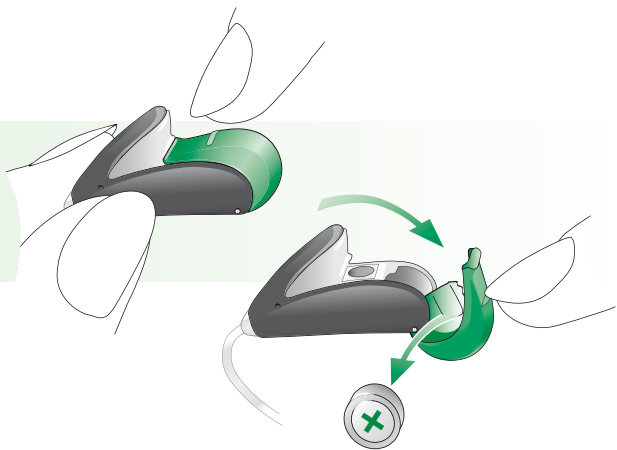



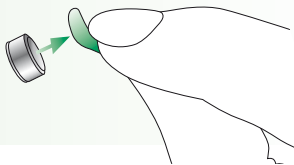

Remove the protective foil from the new battery.

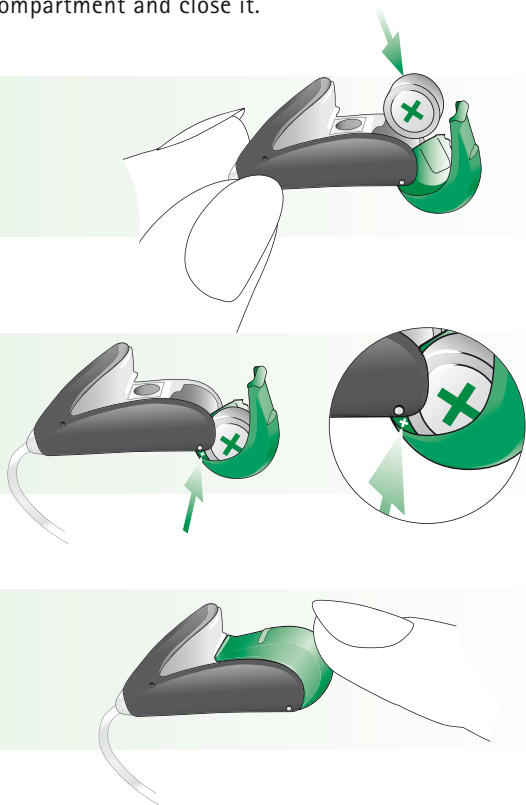

Insert the new battery with the "+" sign (flat side of the battery) in line with the "+" marked on the battery compartment and close it.



Replacing the battery

-  Handle the battery compartment with care and do not use excessive force.
-  If there is any resistance when shutting the compartment, ensure that the battery is inserted correctly. The compartment may not close properly if the battery is upside down and the instrument will not work.
-  When your Audéo is not in use, leave the battery compartment open to allow any moisture to evaporate.
-  We recommend you only use batteries which your Audéo specialist approves and sells.

Low battery warning

An acoustic signal gives you an early warning that the battery is approaching exhaustion. Usually you have at least 30 minutes to replace the battery. With very high quality batteries, this reserve may be much higher and Audéo will repeat the low battery warning approximately every 30 minutes.

Identifying left and right Audéo

It is important to use the correct Audéo for each ear. Your Audéo specialist can mark them for you with a color code placed in the battery compartment. The color code is visible when the battery compartment is opened.

It will identify left and right instruments as follows:

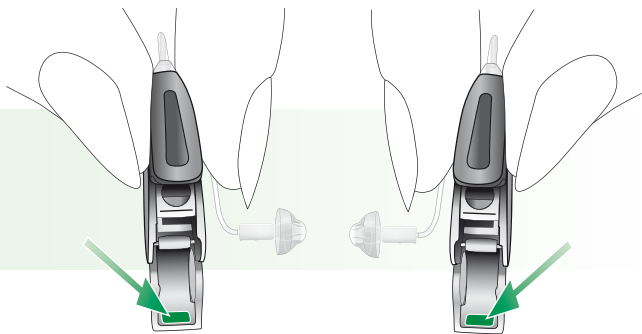

**blue =
left Audéo**

**red =
right Audéo**

Preparation

Inserting Audéo with Fidelity Sound Port and dome into your ear

Open domes

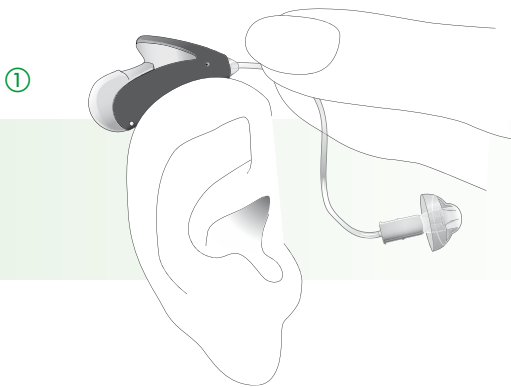

Place the Audéo over the top of your ear ①.

②

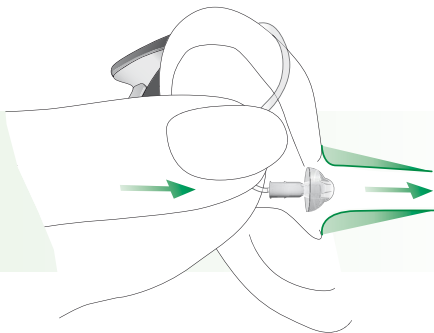

Hold the Fidelity Sound Port where it attaches to the dome ② and gently push the dome into your ear canal.

③

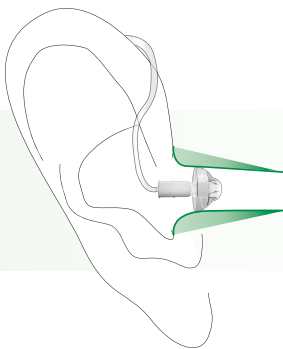

The dome should be placed far enough into the ear so that the wire of the Fidelity Sound Port lies flush with your head ③.

Preparation

Closed domes

The closed dome consists of two fins overlapping each other. Before inserting the closed dome into the ear canal, it is important to check the position of these fins. The bigger fin must be positioned over the smaller fin, see picture ④. If the position is incorrect ⑤, you can easily adjust it. With one finger, just bend smoothly the bigger fin forwards and then back again so that it is overlapping the smaller one, see picture ⑥. Make sure also that the slit of the closed dome is in a horizontal position on the tube unit, as shown in picture ④.

Your Fidelity Sound Port with closed dome is ready to be inserted into the ear, refer to page 10.

Correct position

④



Wrong position

⑤



Moving the fins

⑥

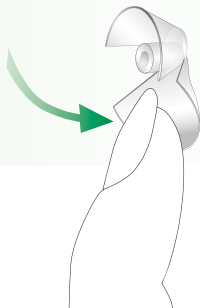

Operation

Switching ON/OFF

Switching OFF

Using the nail grip, slightly open the battery cover until it snaps into its OFF position.

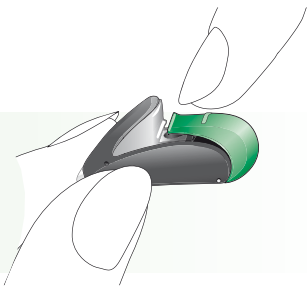

Switching ON

Close the battery compartment by pressing on the base of the instrument.

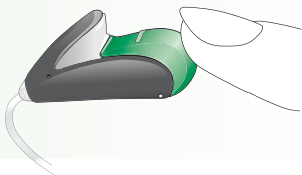

Your Audéo specialist may have delayed the start-up of your Audéo Personal Communication Assistant (9 or 15 seconds once it is switched on), in order to avoid any disturbance when placing it on your ear. The start-up is confirmed by an acoustic signal.

Fine tuning based on your personal preferences (only available in Audéo IX)

Your Audéo specialist will adjust the settings of Audéo based on your personal needs. In order to further customize Audéo to your preferences in your daily life, Audéo IX is equipped with a Self Learning capability. In every environment, Audéo IX logs your personal volume changes. This means that every time you change the volume of your Audéo, this correction is taken into account when you are in a similar environment next time.

Self Learning cleverly ensures that your volume corrections in each environment contribute to a fully personalized volume setting.

To fully benefit from this Self Learning feature, please ask your Audéo specialist to demonstrate to you the available remote controls for your Audéo PCAs.

Remote control (optional)

Remote controls from Phonak allow for discreet and convenient control of all the functions of your Audéo:

- Volume up
- Volume down
- Program changes (if available)

If you wear two Audéo Personal Communication Assistants, the remote control will simultaneously control both of them. This ensures that their volume remains binaurally balanced.

Phonak offers a complete range of modern remote controls. Ask your Audéo specialist to demonstrate them to you. Choose the model that is most convenient for your lifestyle and your taste.

WatchPilot2: exclusive and modern, available for women and men, with sporty rubber band or elegant metal band.



SoundPilot2: direct access to all functions of your Audéo.



Operation

KeyPilot2: small, easy and convenient.

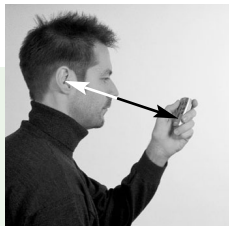

For best results with your KeyPilot or WatchPilot remote control, use as shown.

For detailed information on the use of your remote control, please refer to its user guide.

 Do not use your remote control in locations where it is forbidden to use electronic devices, for instance on airplanes.

Maintenance

Microphone Protector

Important: The Microphone Protector is an exclusive Phonak system designed to protect the Audéo high tech microphones from debris. The Microphone Protector can be replaced if needed. Your Audéo PCAs should not be used without the Microphone Protector.

Your Audéo specialist can tell you whether the Microphone Protector should be exchanged or not.

Important: Consult your Audéo specialist about changing the Microphone Protector if you experience any of the following:

- Audéo sounds quieter than usual.
- There is a reduction in sound quality.
- Understanding in noise becomes more difficult.
- It becomes more difficult to determine the direction of sounds.

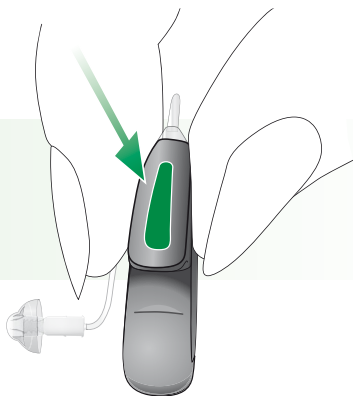

Important points

- 1) Always use new batteries as replacements. You can return empty batteries to your Audéo specialist.
- 2) Protect your Personal Communication Assistants from excessive moisture and heat. Always remove them before showering, bathing or swimming. Do not leave them near windows or in a car. Avoid strong jolts and vibration.
- 3) Daily cleaning and the use of a drying system is highly recommended. We recommend "C&C Line" from Phonak to care for your Audéo. Your Audéo specialist will gladly advise you. Never use household cleaning products (washing powder, soap, etc.) to clean your Personal Communication Assistants.





- 4) Hair spray, face creams and make-up can damage Audéo. Remove the instruments before applying cosmetics.
- 5) If you experience any soreness or inflammation in or behind your ear, contact your Audéo specialist.
- 6) If Audéo fails to operate after you have correctly inserted new batteries, contact your Audéo specialist for advice. Please remember to also bring your remote control, if you use one, together with Audéo for service inquiry.



The symbol with the crossed out disposal bin indicates that this device shall not be treated as household waste. Please hand over your old or unused device to the applicable collection point for the recycling of electrical and electronic equipment or bring your old device to your Audéo specialist for appropriate disposal.

By ensuring this product is disposed of correctly, you will help prevent potential negative effects on the environment and human health.

Warning

-  **Zinc-Air batteries are toxic when swallowed!**
Keep them out of reach of children and pets.
If batteries are swallowed, please seek the advice of a medical practitioner!
-  **Use only Personal Communication Assistants that have been specially programmed for you by an Audéo specialist.** Other devices may be ineffective and may, in certain cases, even damage your hearing.
-  **X-ray radiation (e.g. CT scans, MRI scans) may adversely affect the correct functioning of your PCAs.** We recommend that you remove them before undergoing X-ray procedures and keep them outside the room.
-  **Audéo in directional microphone mode (dSZ) reduces mainly background sounds.** Warning signals coming from behind and vehicles' horns approaching from behind are partially or completely suppressed.

Service and Warranty

Phonak offers you a comprehensive global warranty which becomes effective on the date of purchase. Please ask your Audéo specialist about the details and duration. This warranty covers any repairs due to defects in material and/or workmanship. The warranty does not cover damage from improper handling or care, exposure to chemicals, immersion in water or undue stress. Damage caused by third parties or non-authorized service centers renders the Phonak warranty null and void. This warranty does not include any services performed by an Audéo specialist in his office.

This warranty applies to the Phonak products listed below:

Serial numbers:

Audéo – right:

Audéo – left:

Date of purchase:

Phonak distributors worldwide

Group companies:	(detailed information on www.phonak.com)
Australia	Phonak Australasia Pty. Ltd. Baulkham Hills N. S. W. 2153
Austria	Hansaton Akustische Geräte GmbH 5020 Salzburg
Belgium	Lapperre N.V., 1702 Groot-Bijgaarden
Brazil	CAS Produtos Médicos São Paulo – SP 04363-100
Canada	Phonak Canada Limited Mississauga, Ontario L5S 1V9
China	Phonak (Shanghai) Co. Ltd., Shanghai City 200233
Denmark	Phonak Danmark A/S, Nitvej 10 2000 Frederiksberg
France	Phonak France SA, 69500 Bron
Germany	Phonak GmbH, 70736 Fellbach-Oeffingen EC Representative
Italy	Phonak Italia S.r.l., 20159 Milano
Japan	Phonak Japan Co., Ltd., Tokyo 101-0044
Jordan	Phonak Middle East, 11181 Amman
Netherlands	Phonak B.V., 3439 ME Nieuwegein
New Zealand	Phonak New Zealand Ltd., Takapuna Auckland 9
Norway	Phonak AS, 0105 Oslo
Poland	Phonak Polska Sp. z o.o., 00-567 Warszawa
Spain	Phonak Ibérica S.A., 03008 Alicante
Sweden	Phonak AB, 117 43 Stockholm
Switzerland	Phonak AG, Phonak Schweiz, 8712 Stäfa
United Kingdom	Phonak UK Limited Warrington, Cheshire WA1 1PP
USA	Phonak LLC, Warrenville, IL 60555-3927

**Independent
general agents:**

A complete list of Phonak distributors is available at Phonak's Internet site: www.phonak.com. Please visit us or ask your Audéo specialist for information.

Manufacturer:

Phonak AG, Laubisrütistrasse 28
CH-8712 Stäfa, Switzerland



The CE symbol is confirmation by Phonak AG that Audéo products and accessories meet the requirements of directive 93/42/EEC on medical devices.



This symbol indicates that Audéo products comply with requirements for a BF type applied part according to EN 60601-1.

Safety notice External devices may only be connected if they have been tested in accordance with corresponding IECXXXXX standards. Only use accessories approved by Phonak AG.

Operating conditions Audéo has been designed for trouble-free operation under all ordinary climatic conditions.

Transportation and storage conditions Temperature should not exceed limits of $-20^{\circ}/60^{\circ}$ Celsius at a relative air humidity of 65% for extended periods during transportation and storage. Air pressure between 500 and 1100 hPa is not detrimental to the instrument.



Notes

A series of horizontal dotted lines for writing notes.

Your Audéo specialist:

www.audeoworld.com