

NETWORK PARAMETER METER

N14 TYPE



USER'S MANUAL



CONTENTS

Page

1. APPLICATION.....	5
2. METER SET	5
3. BASIC REQUIREMENTS, OPERATIONAL SAFETY.....	6
4. MOUNTING	6
5. METER DESCRIPTION.....	7
6. N14 PROGRAMMING	12
7. RS-485 INTERFACE	20
8. ERROR CODES	26
9. TECHNICAL DATA.....	26
10. ORDER CODES	29
11. MAINTENANCE AND GUARANTEE.....	30

1. APPLICATION

The N14 meter is a programmable digital panel instrument destined for the measurement of 3-phase, 3 or 4-wire power network parameters, in balanced or unbalanced systems with the simultaneous display of measured quantities and digital transmission of their values.

This network parameter meter enables the control and optimization of power electronic devices, systems and industrial installations.

The N14 meter ensures the measurement of: RMS voltage and current, active, reactive and apparent power, active and reactive energy, power factors, frequency, mean active power (e.g. 15-min mean power).

Voltages and currents are multiplied by given current and voltage ratios of measuring transformers. Indications of power and energy take into consideration programmed ratio values.

The value of each measured quantity can be transmitted to the master system through the RS-485 interface.

The relay output signals the exceeding of the chosen quantity and the impulse output can be used for the consumption control of the 3-phase active energy.

The meter is fixed to the panel by means of screw holders.

2. METER SET

The meter set includes:

- N14 meter 1 pc
- user's manual 1 pc
- guarantee card 1 pc
- holder to fix the meter in a panel 2 pcs

When unpacking, please check the completeness of the set.

3. BASIC REQUIREMENTS AND OPERATIONAL SAFETY

In the security scope, the meter meets the requirements of EN 61010-1 standard.

Remarks concerning the operator safety:

- All operations concerning the meter installation and connections should be carried out by qualified skilled personnel and national regulations for the prevention of accidents must be observed.
- Before connecting the meter to the power, one must check the correctness of connections.
- Do not connect the meter to the network through an autotransformer.
- Before the removal of the meter housing, one must disconnect its supply and all measuring circuits.
- The housing removal from the meter during the guarantee contract causes its cancellation.
- The meter fulfils requirements concerning the electromagnetic compatibility in the industrial environment.
- In the building installation should be a switch or a circuit breaker, situated near the meter, easy accessible for the operator and suitably marked.

4. MOUNTING

The meter is adapted to be mounted in a panel by means of holders acc. to fig.1.

The meter housing is made of a self-extinguishing plastics. Meter dimensions: $96 \times 96 \times 70.5$ mm. One must prepare a hole of $91^{+0.5} \times 91^{+0.5}$ mm in the panel which the thickness should not exceed 6 mm.

The meter must be introduced from the panel front with disconnected supply voltage. At the rear side of the meter there are terminal strips which enable the connection of wires up to 2.5 mm².

After the insertion into the hole, fix the meter by means of two holders.

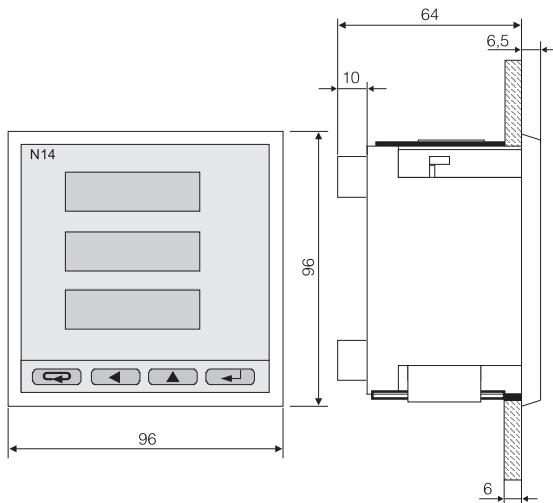

Fig. 1. Overall meter dimensions

5. METER DESCRIPTION

5.1. Current inputs

All current inputs are galvanically isolated (internal current transformers). The meter is adapted to co-operate with external current transformers. Displayed current values and derived quantities are automatically re-counted by the quantity of the introduced external transformer ratio. Current inputs are defined in the order as 1 A or 5 A.

5.2. Voltage inputs

Quantities on voltage inputs are automatically recounted by the quantity of the introduced external voltage transformer ratio.

Voltage inputs are defined in the order as 3 x 57.7/100 V, 3 x 230/400 V or 3 x 400/690 V.

5.3. Connection diagrams

Direct measurement in a 3-wire network

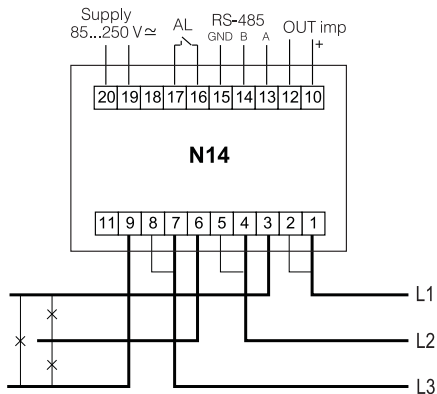

Semi-indirect measurement in a 3-wire network

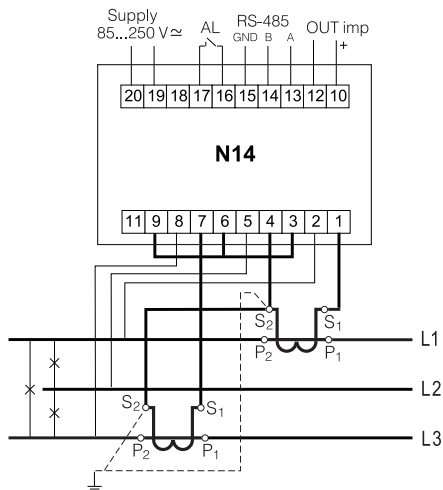

Indirect measurement with the use of 2 current transformers and 2 or 3 voltage transformers in a 3-wire network.

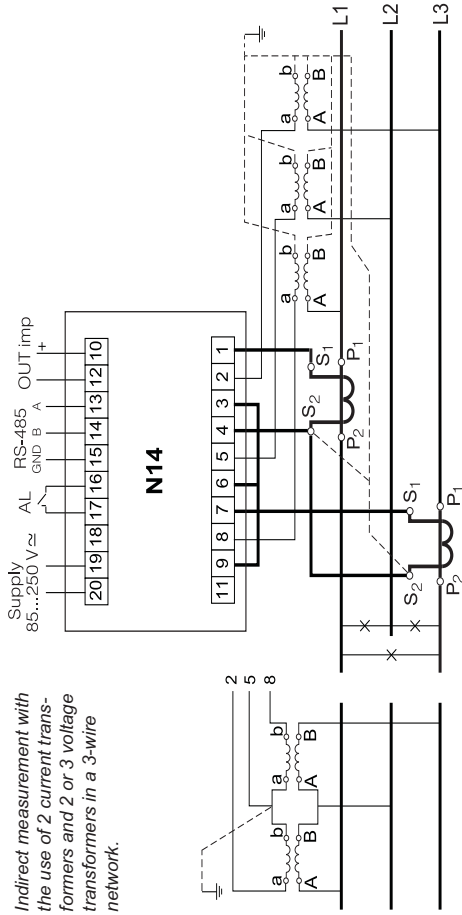

Note: In an industrial environment with high electromagnetic noises it is recommended to earth the terminal 11.

Fig. 2 Meter connection diagrams in a 3-wire network

Direct measurement in a 4-wire network

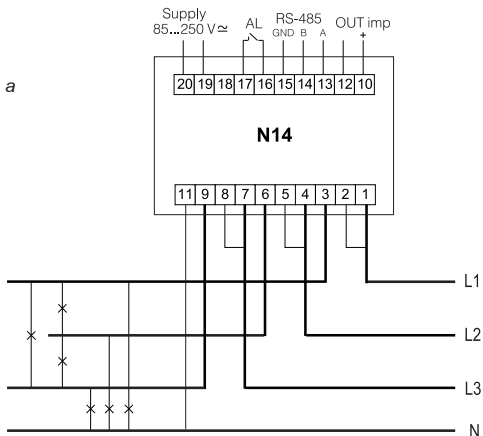

Semi-indirect measurement in a 4-wire network

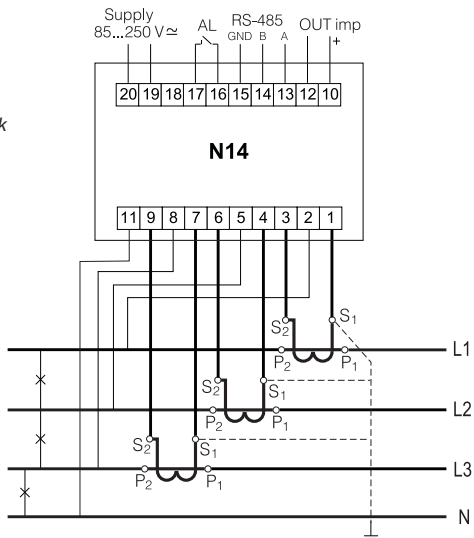

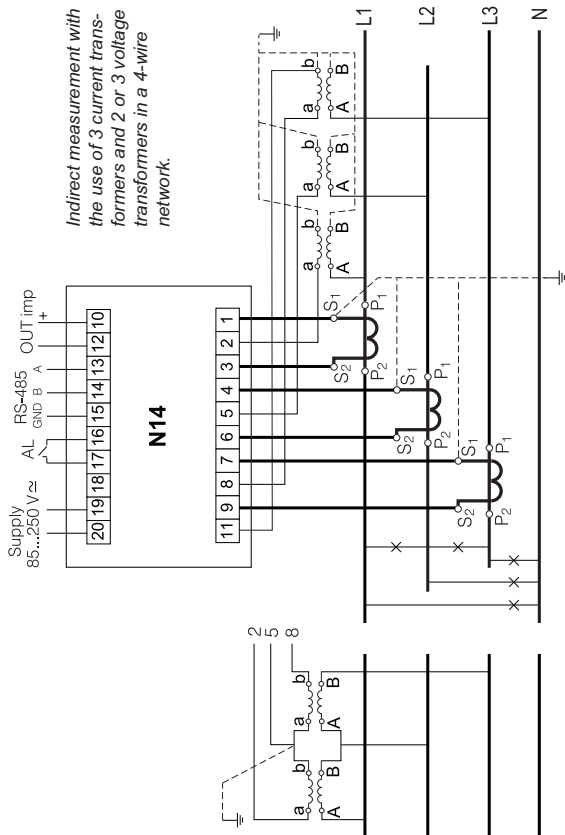

Fig. 3 Meter connection diagrams in a 4-wire network

6. N14 PROGRAMMING

6.1. Frontal panel

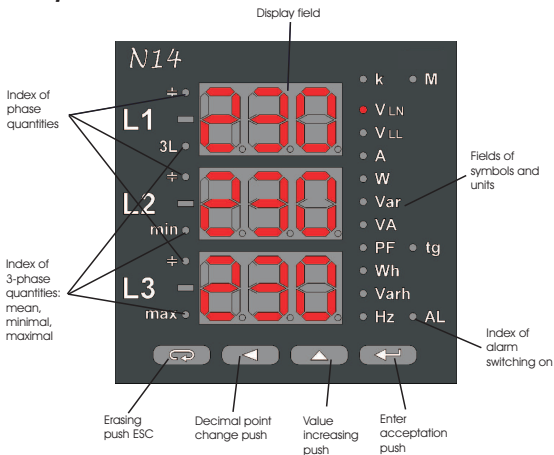

Fig. 4 Frontal panel

6.2. Messages after switching the supply on

After switching the supply on, the meter carries out the display test and displays the name of the N14 meter and the current program version.

Where: n.nn is the number of the current program version or the number of a custom-made version.

Caution! If at the moment of the start, the message Err Cal lub Err EE appears, one must contact an authorized service.

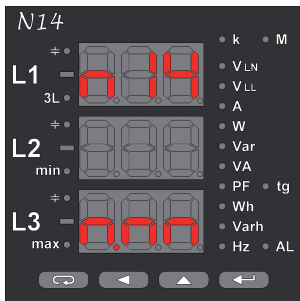

Fig.5. Message after the meter start

6.3. Working modes

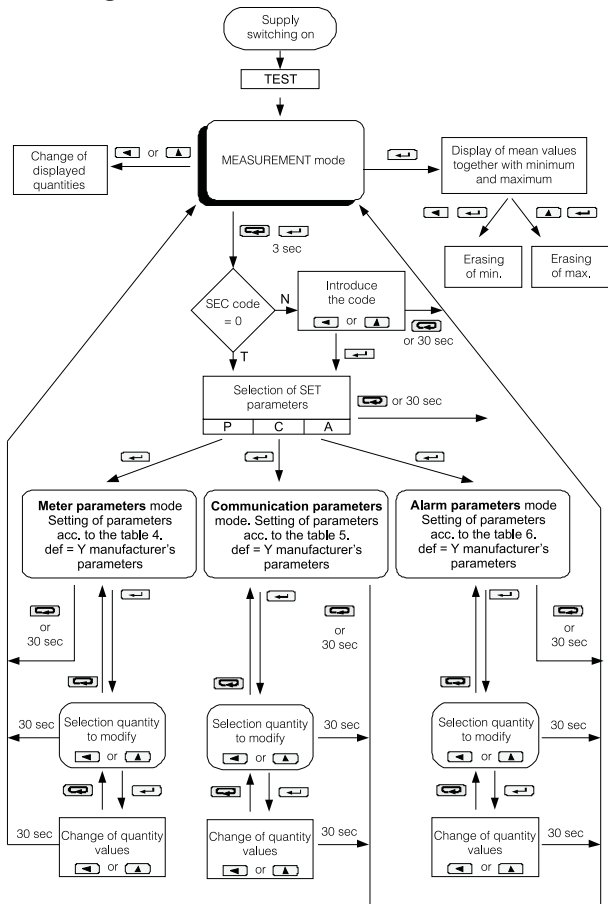







Fig.6. Working modes of N14 meter

6.4. Parametr preview

Quantities are displayed in the measurement mode acc. to the settled tables. The pressure of the  push (left) or  push (top) causes the transition between displayed quantities.

The preview of 3-phase values: mean, minimal and maximal is accessible after pressing the acceptance  (Enter) push. During the preview of these values, the pressure of the  (left) push cancels minimal values, however the  (top) push, maximal values.

Accessible measuring quantities

Basic quantities:

Table 2

Symbol indexes are highlighted		VLN	VLL	A	W	Var	VA	PF	tg	kWh*	- kWh*
Values displayed in:	row 1	U1	U12	I1	P1	Q1	S1	PF1	tg1	EnP input power	EnP output power
	row 2	U2	U23	I2	P2	Q2	S2	PF2	tg2		
	row 3	U3	U31	I3	P3	Q3	S3	PF3	tg3		
						kVarh*	 kVarh*	Hz	W (15 min.)		
						EnQ inductive	EnQ capacitive	f1	PAu		
								min	min		
								max	max		

Mean, minimal, maximal quantities
(indexes 3L, min, max are highlighted).

Table 3

Symbol indexes are highlighted		VLN	VLL	A	W	Var	VA	PF	tg*
Values displayed in:	row 1	U _{mean} phases	U _{mean} between phases	I _{mean} phase	P _{mean} 3phase	Q _{mean} 3phase	S _{mean} 3phase	PF _{mean} phase	tg _{mean} phase
	row 2	min	min	min	min	min	min	min	min
	row 3	max	max	max	max	max	max	max	max

* - available from the program version 1.05.

At capacitive load, during the display of reactive power, the index showing the load character  is highlighted. The exceeding of the upper indication range is signaled on the display by upper horizontal dashes, however the lower range exceeding is signaled by lower horizontal dashes. The mean active power 15-min PAu is displayed after a full interval of the 15-min mean time. In case when the full interval of time is not expired, the message Err is displayed.

The display of errors was described in the chapter 8.

The alarm relay switching on is signaled by the AL index highlighting.

6.5. Setting of parameters

The entry in the programming mode is carried out by pressing and holding during ca 3 sec.  and  pushes.

The entry in the programming mode is protected by the access code. In case when there is no code, the program transits into the programming option. The inscription SET (in the first column) and symbols of respective levels **P**, **C**, **A** are displayed.

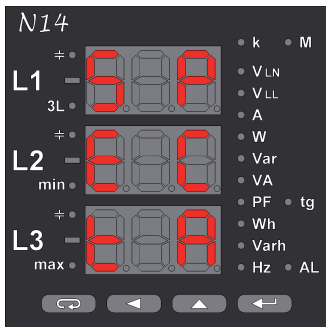







Fig. 7. Menu setup

6.5.1. Setting of meter parameters

Select the mode **P** in options (by  or  pushes) and confirm the choice by the  push.

Table 4

Parameter name	Access code	Current ratio	Voltage ratio	Energy erasing	Erasing of 15-minut active power	Restoration of manufacturer values
Displayed information	SEC	t _I	t _U	En0	PA0	dEF
Default value	0	1	1	no	no	no
Range of changes	0...999	1...10000	1...4000	YES/no	YES/no	YES/no

Following values are set by means of  and  pushes: Position of the decimal digit is selected by the  push, the digit value is increased by the  push. The active position is signalled by the cursor. The value is accepted by the  push or abandoned by pressing the  push. During the acceptance, one can check if the value is contained in the range.

In case of the value setting beyond the range, the meter remains in the parameter edition mode, however the value is set on the maximal value (if the value is too high) or on the minimal value (if the value is too small).

Caution: to display and set 4 and 5-digit parameters (t_U, t_I) two lower display rows are used.

6.5.2. Setting of communication parameters

In options, select the mode **C** and confirm the choice by the  push.

Table 5

Parameter name	Meter address	Interface mode	Interface rate	Restoration of manufacturer values
Displayed information	Adr	trY	bAU	dEF
Default value	1	8n2	9.6 k	no
Range of changes	1...247	8n2, 8e1, 8o1, 8n1	4.8, 9.6, 19.2, 38.4 k	YES/no

6.5.3. Setting of alarm parameters

In options, select the mode **A** and confirm the choice by the  push.

Table 6

Parameter name	Monitored quantity	Kind of alarm operation	Upper switching value (in %)	Lower switching value (in %)	Time delay of the reaction (in sec.)	Restoration of manufacturer values
Displayed information	A_n	A_t	Aon	Aof	Adt	dEF
Default value	oFF	nor	101	99	0	no
Range of changes	see table 7	nor, on, oFF, hon, hoF	0...120	0...120	0...300	YES/no

Selection of monitored quantity:

Table 7

Item value in register 4006	Displayed parameter	Kind of quantity	Value to calculate alarm value percentages and outputs
00	off	lack of quantity /alarm disabled/	none
01	U_1	voltage phase L1	Un[V]*
02	I_1	current in phase L1	In [A]*
03	P_1	active power of phase L1	Un x In x cos(0°) [W]*
04	q_1	reactive power of phase L1	Un x In x sin(90°) [var]*
05	S_1	apparent power of phase L1	Un x In [VA]*
06	PF1	active power factor of phase L1	1
07	U_2	voltage - phase L2	Un [V]*
08	I_2	current in phase L2	In [A]*
09	P_2	active power of phase L2	Un x In x cos(0°) [W]*
10	q_2	reactive power of phase L2	Un x In x sin(90°) [var]*

Table 7 (continuation)

11	S ₂	apparent power of phase L2	$U_n \times I_n$ [VA]*
12	PF ₂	active power factor of phase L2	1
13	U ₃	voltage - phase L3	U_n [V]*
14	I ₃	current in phase L3	I_n [A]*
15	P ₃	active power of phase L3	$U_n \times I_n \times \cos(0^\circ)$ [W]*
16	q ₃	reactive power of phase L3	$U_n \times I_n \times \sin(90^\circ)$ [var]*
17	S ₃	apparent power of phase L3	$U_n \times I_n$ [VA]*
18	PF ₃	active power factor of phase L3	1
19	U _A	3-phase mean voltage	U_n [V]*
20	I _A	3-phase mean current	I_n [A]*
21	P	3-phase active power	$3 \times U_n \times I_n \times \cos(0^\circ)$ [W]*
22	q	3-phase reactive power	$3 \times U_n \times I_n \times \sin(90^\circ)$ [var]*
23	S	3-phase apparent power	$3 \times U_n \times I_n$ [VA]*
24	PFA	3-phase active power factor	1
25	F	frequency	100 [Hz]
26	U ₁₂	phase-to-phase voltage L1-L2	$\sqrt{3} U_n$ [V]*
27	U ₂₃	phase-to-phase voltage L2-L3	$\sqrt{3} U_n$ [V]*
28	U ₃₁	phase-to-phase voltage L3-L1	$\sqrt{3} U_n$ [V]*
29	U _{4A}	phase-to-phase mean voltage	$\sqrt{3} U_n$ [V]*
30	PA _u	active mean power	$13 \times U_n \times I_n \times \cos(0^\circ)$ [W]*
31	tg1	tgφ factor of phase L1	1
32	tg2	tgφ factor of phase L2	1
33	tg3	tgφ factor of phase L3	1
34	tga	3-phase tgφ factor	1

* U_n, I_n - rated values of voltages and currents

a) **nor**

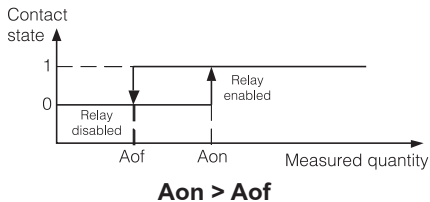

b) **nor**

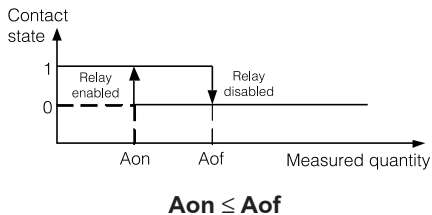

c) **On**

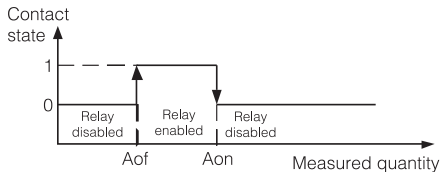

d) **OFF**

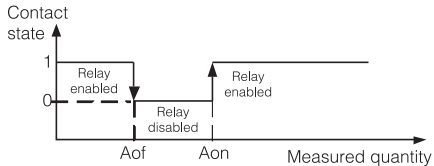

Fig. 8. Alarm types: a),b) normal c) disabled d) enabled.

Remained types of alarms: hon – always enabled; hof – always disabled.

Example of alarm setting:

Set the alarm of **nor** for **Aon > Aof**, for the monitored 3-phase active Power **P**

Version: 5 A; 3 x 230/400 V. Alarm enabled after exceeding 3800 W, alarm disabled after decreasing 3100 W.

Calculation:

rated 3-phase active Power: $P = 3 \times 230 \text{ V} \times 5 \text{ A} = 3450 \text{ W}$

3450 W – 100% 3450 W – 100%

3800 W – Aon% 3100 W – AoF%

Therefore: Aon = 110 % AoF = 90%

Set: Monitored quantity: P; Kind of alarm: nor, Aon 110, AoF 90.

7. INTERFACE RS-485

Set of the N14 meter serial link parameters:

- identifier 0xAC
- meter address 1...247
- baud rate 4.8, 9.6, 19.2, 38.4 kbit/s,
- working mode Modbus RTU,
- information unit 8N2, 8E1, 8O1, 8N1,
- maximal response time 1000 ms.
- Implemented functions: 03, 16, 17
 - 03 - register readout,
 - 16 - register write,
 - 17 - device identification.

Manufacturer's settings: address 1, baud rate 9600 bit/s, RTU 8N2 mode.

Register map of the N14 meter.

In the N14 meter, data are placed in 16 and 32-bit registers.

Process variables and meter parameters are placed in the address area of registers in the way dependent on the variable value type.

Bits in the 16-bit registers are numbered from the youngest to the oldest (b0-b15). 32-bit registers include numbers of float type in the IEEE-754 standard.

Table 8

Address range	Type of value	Description
4000 – 4023	Integer (16 bits)	Value placed in one 16-bit register. Description of registers are included in the table 9. Registers for write and readout.
7000 – 7133*	Float (2 × 16 bits)	Value placed in two successive 16-bit registers. Registers contain the same data as 32-bit registers from the area 7500. Registers for readout.
7500 – 7566	Float (32 bits)	Value placed in one 32-bit register. Description of registers are included in the table 10. Registers for readout.

* accessible from the program version 1.04

Table of 16 – bit registers for N14 meter

Table 9

Register address	Operations	Range	Description	Default
4000	RW	0...999	Access code to parameters	0
4001	RW	1...10000	Ratio of the current transformer	1
4002	RW	1..4000	Ratio of the voltage transformer	1
4003	RW	0.1	Erasing of watt-hour meters	0
4004	RW	0.1	Erasing of 15-minute active Power PAV	0
4005	RW	0.1	Erasing of min. and max.	0
4006	RW	0.1...30	Quantity on the relay output	0
4007	RW	0..4	Output type: 0 – nor, 1- on, 2 - oFF,3 - hon, 4 - hoFF	
4008	RW	0...120%	Upper value of alarm switching (relay)	101
4009	RW	0...120%	Lower value of alarm switching (relay)	99
4010	RW	0...300s	Delay of alarm switching	0
4011	RW	0...247	Address in MODBUS network	1
4012	RW	0...3	Transmission mode: 0->8n2, 1->8e1, 2->8o1, 3->8n1	0
4013	RW	0...3	Baud rate: 0->4800, 1->9600, 2->19200, 3->38400	1
4014	RW	0...1	Acceptation of above transmission parameters	0
4015	R	0...15258	Active energy, two older bytes*	0

Table 9

4016	R	0..65535	Active energy, two younger bytes*	0
4017	R	0..15258	Reactive energy, two older bytes*	0
4018	R	0..65535	Reactive energy, two younger bytes*	0
4019	R	0..65535	Status register - description below*	0
4020	R	0..15258	Output active energy, two older bytes*	0
4021	R	0..65535	Output active energy, two younger bytes*	0
4022	R	0..15258	Reactive capacitive energy, two older bytes*	0
4023	R	0..65535	Reactive capacitive energy, two younger bytes*	0

* - available from the program version 1.05. In prior versions, registers 4015 - 4018 include energy from totalized modules of individual energies.

Energies are made available in hundreds of watt-hours (var-hours) in two 16-bit registers, therefore when calculating values of particular energies from registers they must be divided by 10, id:

Input active energy = (value of register 4015 * 65536 + value of register 4016)/10 [kWh]

Developed reactive energy = (value of register 4017 * 65536 + value of register 4021)/10 [kWh]

Reactive inductive energy = (value of register 4017* 65536 + value of register 4018)/10 [kVarh]

Reactive capacitive energy = (value of register 4022* 65536 + value of register 4023)/10 [kVarh]

Status register:

Bit 15 – relay output state „1” – On, „0” - off

Bit 14 – „1” – FRAM damaged

Bit 13 – „1” – lack of calibration or erroneous calibration

Bit 12 – „1” – active calibration

Bit 11 – reserved

Bit 10 – „1” – the interval of power averaging does not elapse

Bit 09 – „1” –error of parameter values in FRAM

Bit 08 – „1” – error of energy value in FRAM

Bit 7 – reserved

Bit 6 – „1” – too small voltage for frequency measurement

Bit 5 – „1” – too small voltage in phase C

Bit 4 – „1” – too small voltage in phase B

Bit 3 – „1” – too small voltage in phase C

Bit 2 – current range „0” – 1 A~; 1” – 5 A~

Bit 1	Bit 0	voltage range
0	0	57.8 V~
0	1	230 V~
1	0	400 V~

Table of 32 bit registers for N14 meter

Table 10

16-bit Register address	32-bit Register address	Operation	Description	Unit
7000	7500	R	Voltage of phase L1	V
7002	7501	R	Current of phase L1	A
7004	7502	R	Active power of phase L1	W
7006	7503	R	Reactive power of phase L1	Var
7008	7504	R	Apparent power of phase L1	VA
7010	7505	R	Active power factor of phase L1	-
7012	7506	R	Ratio of reactive power/active power of phase L1	-
7014	7507	R	Voltage of phase L2	V
7016	7508	R	Current of phase L2	A
7018	7509	R	Active power of phase L2	W
7020	7510	R	Reactive power of phase L2	Var
7022	7511	R	Apparent power of phase L2	VA
7024	7512	R	Active power factor of phase L2	-
7026	7513	R	Ratio of reactive power/active power of phase L2	-
7028	7514	R	Voltage of phase L3	V
7030	7515	R	Current of phase L3	A
7032	7516	R	Active power of phase L3	W
7034	7517	R	Reactive power of phase L3	Var
7036	7518	R	Apparent power of phase L3	VA
7038	7519	R	Active power factor of phase L3	-
7040	7520	R	Ratio of reactive power/active power of phase L3	-
7042	7521	R	Mean 3-phase voltage	V
7044	7522	R	Mean 3-phase current	A
7046	7523	R	3-phase active power	W
7048	7524	R	3-phase reactive power	Var
7050	7525	R	3-phase apparent power	VA
7052	7526	R	Mean active power factor	-
7054	7527	R	Ratio of mean reactive Power/mean active power	-
7056	7528	R	Frequency	Hz
7058	7529	R	Phase-to-phase voltage L1-L2	V
7060	7530	R	Phase-to-phase voltage L2-L3	V
7062	7531	R	Phase-to phase voltage L3-L1	V

Table of 32 bit registers for N14 meter

Table 10

7064	7532	R	Mean phase-to-phase voltage	V
7066	7533	R	Mean 15-minute active power	W
7068	7534	R	Reserved	
7070	7535	R	Reserved	
7072	7536	R	Mean minimal 3-phase voltage	V
7074	7537	R	Mean maximal 3-phase voltage	V
7076	7538	R	Mean minimal 3-phase current	A
7078	7539	R	Mean maximal 3-phase current	A
7080	7540	R	Minimal 3-phase active power	W
7082	7541	R	Maximal 3-phase active power	W
7084	7542	R	Minimal 3-phase reactive power	var
7086	7543	R	Maximal 3-phase reactive power	var
7088	7544	R	Minimal 3-phase apparent power	VA
7090	7545	R	Maximal 3-phase apparent power	VA
7092	7546	R	Minimal active power factor	-
7094	7547	R	Maximal active power factor	-
7096	7548	R	Minimal mean 3-phase reactive power factor/ active power factor ratio	-
7098	7549	R	Maximal mean 3-phase reactive power factor/active power factor ratio	-
7100	7550	R	Minimal frequency	Hz
7102	7551	R	Maximal frequency	Hz
7104	7552	R	Minimal mean phase-to-phase voltage	V
7106	7553	R	Maximal mean phase-to phase voltage	V
7108	7554	R	Minimal mean 15-minute active power	W
7110	7555	R	Maximal mean 15-minute active power	W
7112	7556	R	3-phase active energy (number of the register 7557 overfills, zeroed after exceeding 99999999.9 kWh)*	100 MWh
7114	7557	R	3-phase active energy (counter totting to 99999.9 kWh)*	kWh

7116	7558	R	3-phase reactive inductive energy (number of the register 7559 overfills, zeroed after exceeding 99999999.9 kVarh)*	100 MWh
7118	7559	R	3-phase reactive inductive energy (counter totting to 99999.9 kVarh)*	kWh
7120	7560	R	3-phase reactive inductive energy (number of the register 7559 overfills, zeroed after exceeding)	100 MVarh
7122	7561	R	Developed 3-phase active energy (counter totting to 99999.9 kWh)*	kVarh
7124	7562	R	3-phase reactive capacitive energy (number of the register overfills: 7563, zeroed after exceeding 99999999.9 kVarh)*	100 MVarh
7126	7563	R	3-phase reactive capacitive energy (counter totting up to 99999.9 kVarh)*	kVarh
7128	7564	R	Shift angle between voltage and current of phase 1*	°
7130	7565	R	Shift angle between voltage and current of phase 2*	°
7132	7566	R	Shift angle between voltage and current of phase 3*	°

* - available from the program version 1.05. In prior versions, registers 7556-7559 include energies from totalized modules of industrial energies.

In case of errors, the value 1e20 is written in appropriate registers.

8. ERROR CODES

Messages about errors can appear during the meter operation.

Reasons of these errors are presented below.

Err - when the voltage or current is too low during the meter work:

- P_{fi} , $t_{\phi i}$ below 10% U_n , I_n
- f below 10% U_n
- The full time interval of power averaging PAu does not elapse.

9. TECHNICAL DATA

Measuring ranges and admissible basic errors are presented in the table 11.

Table 11

Measured value	Indication range K_i ; $K_u \neq 1$	Measuring range K_i ; $K_u = 1$	L1	L2	L3	Σ	Basic error
Current 1/5 A L1...L3	0.00...9.99 kA	0.02...6 A~	•	•	•		$\pm 0.5\%$
Voltage L-N	0.0...289 kV	2.9...480 V~	•	•	•		$\pm 0.5\%$
Voltage L-L	0.0...500 kV	10...830 V~	•	•	•		$\pm 1\%$
Frequency	45.0...70.0 Hz	45.0...100.0 Hz	•	•	•		$\pm 0.2\%$
Active power	-999 MW...0.00 W ...999 MW	-2.64 kW...1.4 W ...2.64 kW	•	•	•	•	$\pm 1\%$
Reactive power	-999 Mvar...0.00 var ...999 Mvar	-2.64 kvar...1.4 var ...2.64 kvar	•	•	•	•	$\pm 1\%$
Apparent power	0.00 VA...999 MVA	1.4 VA...2.64 kVA	•	•	•	•	$\pm 1\%$
Power factor PF	-1 .. 0 .. 1	-1.2 .. 0 .. 1.2	•	•	•	•	$\pm 2\%$
Tangens ϕ	-1.2 .. 0 .. 1.2	-1.2 .. 0 .. 1.2	•	•	•	•	$\pm 2\%$
Angle between U_f and I_f	-180 ... 180°	-180 ... 180°	•	•	•		$\pm 0.5\%$
Input active energy	0 .. 99 999 999.9 kWh					•	$\pm 1\%$
Developed active energy	0 .. 99 999 999.9 kWh					•	$\pm 1\%$
Reactive inductive energy	0 .. 99 999 999.9 kVarh					•	$\pm 1\%$
Reactive capacitive energy	0 .. 99 999 999.9 kVarh					•	$\pm 1\%$

K_u - ratio of voltage transformer: 1... 4000

K_i - ratio of current transformer: 1... 10000

Caution! For a correct current measurement, the voltage presence of a value higher than 0.05 U_n is required at least for one phase.

Power consumption:

- in the supply circuit $\leq 6 \text{ VA}$
- in the voltage circuit $\leq 0.05 \text{ VA}$
- in the current circuit $\leq 0.05 \text{ VA}$

Display field

3×3 LED digits, 14mm height,
red colour

Relay output

relay, voltageless, NOC contacts
load capacity: $250 \text{ V} \sim / 0.5 \text{ A} \sim$

Serial interface RS-485

address: 1..247;
mode: 8N2, 8E1, 8O1, 8N1;
rate: 4.8, 9.6, 19.2, 38.4 kbit/s

Impulse energy output

output of O/C type, passive of
class A acc. to EN 62053-31;
supply voltage 18...27 V,
current 10...27 mA

**Impulse constant of the
O/C type output**

5000 imp/kWh, independently of
set K_u , K_i ratios

**Protection degree ensured
by the housing:**

- from the frontal side IP 40
- from terminal side IP 10

Weight

0.3 kg

Dimensions

$96 \times 96 \times 70.5 \text{ mm}$

Panel cut-out dimensions

$91^{+0.5} \times 91^{+0.5} \text{ mm}$

Reference conditions and rated operating conditions:

- supply voltage $85 \dots 253 \text{ V d.c. or a.c., } 40 \dots 400 \text{ Hz}$
- input signal: $0 \dots \underline{0.005 \dots 1.2} I_N; \underline{0.05 \dots 1.2} U_N;$ for voltage,
current
 $0 \dots \underline{0.1 \dots 1.2} I_N; 0 \dots \underline{0.1 \dots 1.2} U_N;$ for power
factors $P_{fi}, \varphi_i,$ frequency $\underline{45 \dots 66 \dots 100 \text{ Hz}};$
sinusoidal ($\text{THD} \leq 8\%$)

- power factor	-1 .. 0 .. 1
- ambient temperature	- 25...23...+55°C
- storage temperature	- 30... +70°C
- relative air humidity	25... 95% (condensation inadmissible)
- admissible peak factor:	
- current	2
- voltage	2
- external magnetic field	<u>0... 40... 400 A/m</u>
- short duration overload capacity (5 s):	
- voltage inputs	2 Un (max.1000 V)
- current inputs	10 In
- work position	any
- warm-up time	5 min.

Additional errors in % of the basic error:

- from frequency of input signals	< 50%
- from ambient temperature changes	< 50%/10°C
- for THD > 8%	< 100 %

Standards fulfilled by the meter:

Electromagnetic compatibility:

- noise immunity acc. to EN 61000-6-2
- interference emission acc. to EN 61000-6-4

Safety requirements acc to EN 61010-1 standard:

- isolation between circuits: basic,
- installation category: III,
- pollution degree: 2,
- maximal working voltage in relation to earth: 600 V - kat II (300 V - kat III)
- altitude above sea level, < 2000 m.

10. ORDER CODES

Table 9

NETWORK PARAMETER METER	N14 -	X	X	XX	X
Input current I_n					
1 A (X/1)		1			
5 A (X/5)		2			
Input voltage (phase/phase-to-phase) U_n					
3 × 57.7/100 V		1			
3 × 230/400 V		2			
3 × 400/690 V*		3			
Kind of version					
standard					00
input voltage 3 x 110/190 V					01
custom-made					XX
Additional requirements					
without an extra quality inspection certificate.....					8
with a extra quality inspection certificate.....					7
acc. to customer's agreement**					X

* Execution only for direct measurement

** The version code is established by the manufacturer

ORDER EXAMPLE

The **N14-2-2-00-7** code means:

N14 – network parameter meter of N14 type

2 – input current 5 A (X/5)

2 – input voltage 3 x 230/400 V

00 – standard version

7 - delivered with an extra quality inspection certificate

11. MAINTENANCE AND GUARANTEE

The N14 network parameter meter does not require any periodical maintenance.

In case of some incorrect operations:

1. In the period of 12 months from the date of purchase:

One should take the transducer down from the installation and return it to the Manufacturer's Quality Control Dept.

If the unit has been used in compliance with the instructions, the Manufacturer warrants to repair it free of charge.

2. After the guarantee period:

One should turn over the transducer to repair it in a certified service workshop. The disassembling of the housing causes the cancellation of the granted guarantee.

Spare parts are available for the period of five years from the date of purchase.

Our policy is one of continuous improvement and we reserve the right to make changes in design and specifications of any products as engineering advances or necessity requires and revise the above specifications without notice.

N14-09C

