ST-NXP Wireless

IMPORTANT NOTICE

Dear customer,

As from August 2nd 2008, the wireless operations of NXP have moved to a new company, ST-NXP Wireless.

As a result, the following changes are applicable to the attached document.

- **Company name - NXP B.V.** is replaced with **ST-NXP Wireless**.
- **Copyright** - the copyright notice at the bottom of each page “© NXP B.V. 200x. All rights reserved”, shall now read: “© ST-NXP Wireless 200x - All rights reserved”.
- **Web site** - <http://www.nxp.com> is replaced with <http://www.stnwireless.com>
- **Contact information** - the list of sales offices previously obtained by sending an email to salesaddresses@nxp.com , is now found at <http://www.stnwireless.com> under Contacts.

If you have any questions related to the document, please contact our nearest sales office. Thank you for your cooperation and understanding.

ST-NXP Wireless



UM10014

ISP1520 Hi-Speed USB Hub Demo Board

Rev. 06 — 29 October 2007

User manual

Document information

Info	Content
Keywords	isp1520, hub controller, usb, universal serial bus
Abstract	This document describes the ISP1520 hub demo board. It also contains the related schematics, the PCB layout, and the bill of material.

Revision history

Rev	Date	Description
06	20071029	Sixth release. Corrected Fig 9 : the SW1 TEST_HIGH block.
05	20070124	Fifth release. Updated Section 6. Updated ESD part type in Table 7.
04	20040511	Fourth release. Updated Section 6.
03	20040414	Third release. Updated the following: Section 2. Section 4. Section 5.5. Section 6.
02	20030410	Second release. Updated Section 5.5 and Section 6.
01	20021126	First release.

Contact information

For additional information, please visit: <http://www.nxp.com>

For sales office addresses, please send an email to: salesaddresses@nxp.com

1. Introduction

The ISP1520 is a Hi-Speed Universal Serial Bus (USB) hub IC, with four downstream facing ports. The ISP1520 hub demo board is designed to demonstrate the features and functionality of the ISP1520. This version is targeted at low-cost designs. Nevertheless, it still contains a lot of features and options to be evaluated.

This document describes the ISP1520 hub demo board. It also contains related schematics, the PCB layout, and the bill of material.

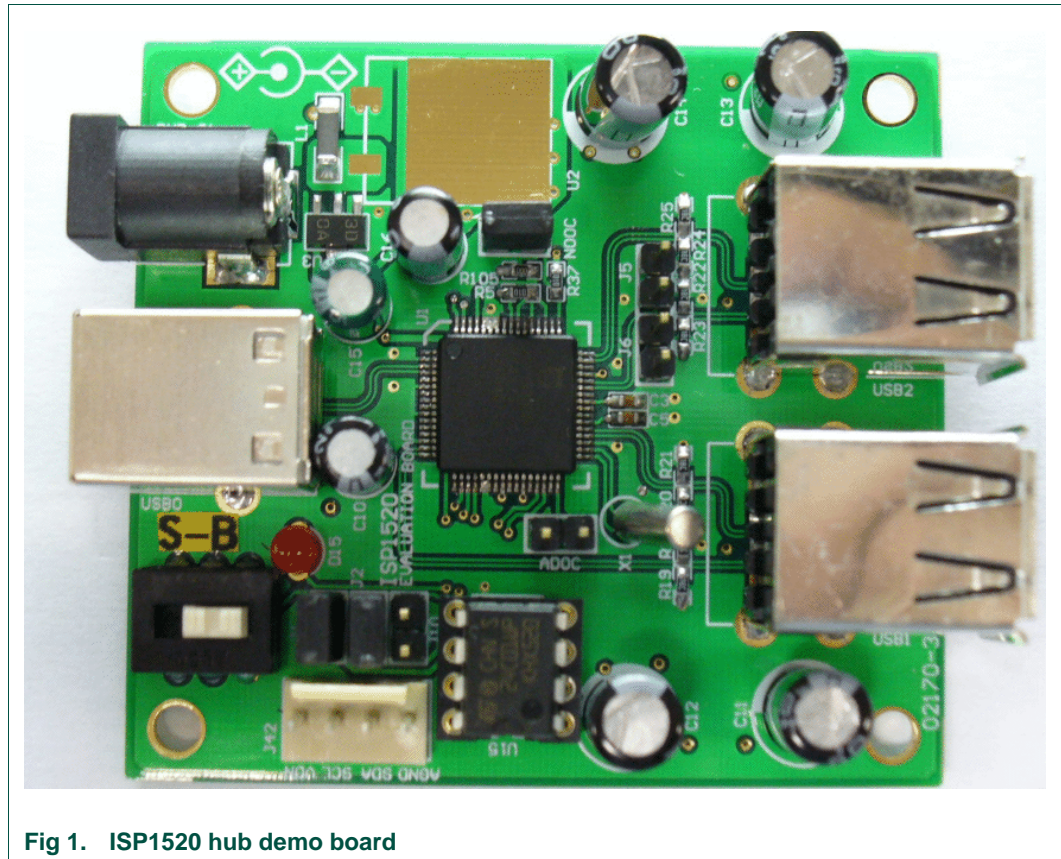

Fig 1. ISP1520 hub demo board

2. ISP1520 hub demo board features

- Complies with *Universal Serial Bus Specification Rev. 2.0*
- Supports self-powered operation
- Configurable number of downstream facing ports (from two to four)
- Customizable vendor ID, product ID and serial number, by using an external EEPROM or an external microcontroller
- Individual power switching and individual overcurrent protection
- USB traffic indication (GoodLink LED) on the upstream facing port

3. System requirements

This hub can be attached to a computer that has a USB or Hi-Speed USB host installed, and running any of these operating systems:

- Microsoft Windows 98
- Windows Me
- Windows 2000
- Windows XP
- Mac OS

If this hub is plugged into a USB host controller, it will only work as a full-speed hub.

4. Power supply adapter requirements

Regulated output: $5.1V_{CC} \pm 5\%$, 2.5 A

Warning: If you are using board version 02170-2, ensure that the power plug polarity is (+) at the core and (-) at the outer shield.

5. Hub demo board description

5.1 ISP1520 64-pin LQFP package

The ISP1520 has the following port configurations:

- One Hi-Speed USB and Original USB capable upstream facing port (USB0), and
- Four Hi-Speed USB and Original USB capable downstream facing ports (USB1, USB2, USB3, USB4)

Downstream facing ports USB3 and USB4 can be disabled. By design, ports USB1 and USB2 cannot be disabled.

[Table 1](#) shows the jumper setting versus port activation.

Table 1. Jumper setting vs. port activation

J6, J5	Active ports
Off, off	1, 2, 3, 4* ^[1]
On, on	1, 2

[1] * - Indicates default setting.

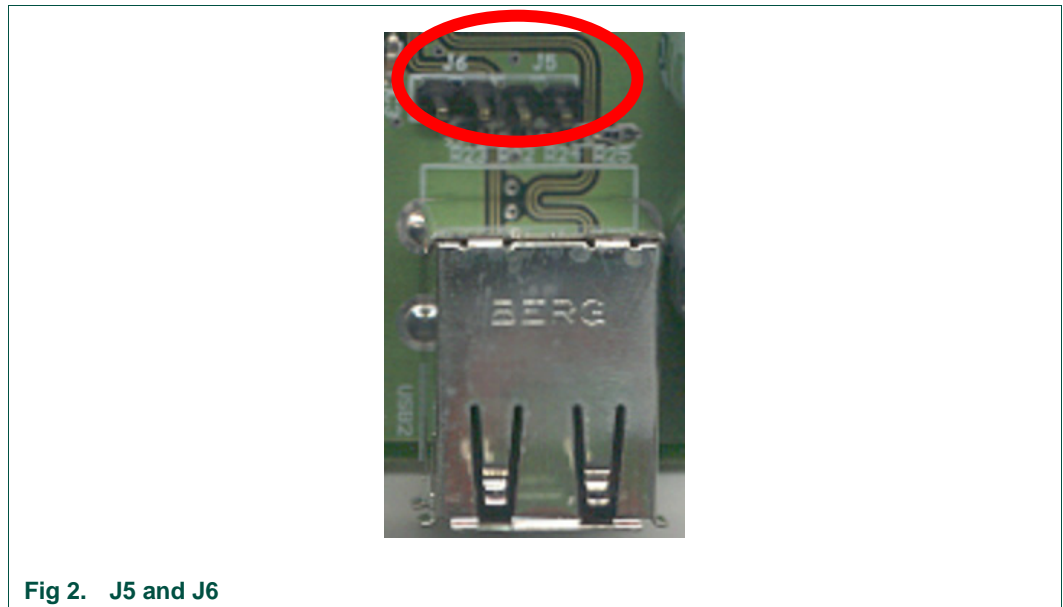

Fig 2. J5 and J6

5.2 GoodLink indicator

NXP GoodLink LED D15 (red) is located near the upstream facing port. This LED blinks on every successful USB transaction.



Fig 3. GoodLink D15

5.3 Port power switch transistors

The hub switches the bus power of each downstream facing port through a low ohmic Positive Metal Oxide Silicon (PMOS) transistor.

5.4 Overcurrent circuit detection

The integrated analog overcurrent detection circuit of the ISP1520 senses the voltage drop across the power switch. When the port draws too much current, the voltage drop across the power switch exceeds the trip voltage threshold. The overcurrent circuit detects this and automatically switches off the power switch. More information on choosing the switch and trimming the overcurrent detection voltage can be found in the *ISP1520 Hi-Speed Universal Serial Bus hub controller* data sheet.

The hub demo board also contains an option to disable the overcurrent detection. This can be done in two stages. First place the NOOC jumper in the appropriate position to set the hub's descriptor (see [Table 2](#)).

Table 2. Overcurrent detection selection using NOOC

NOOC	Overcurrent detection	Logic state
On	yes	0 (LOW)
Off	no	1 (HIGH)

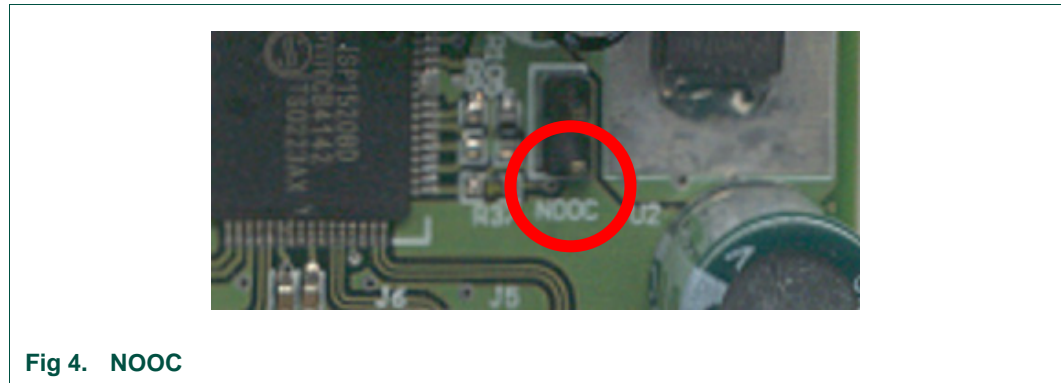

Fig 4. NOOC

Then, de-solder R28, R29, R30 and R31, and solder R32, R33, R34 and R36 on the PCB (see schematics).

As a lower cost alternative, there are provisions on the board to use polyswitches to handle overcurrent conditions. In this case, the port switching transistors are bypassed. If this solution is preferred, then the overcurrent detection circuit inside the chip must be switched to digital mode.

Table 3. Mode selection using ADOC

ADOC	Mode	Logic state
On	digital	0 (LOW)
Off	analog ^[1]	1 (HIGH)

[1] *- Default settings.

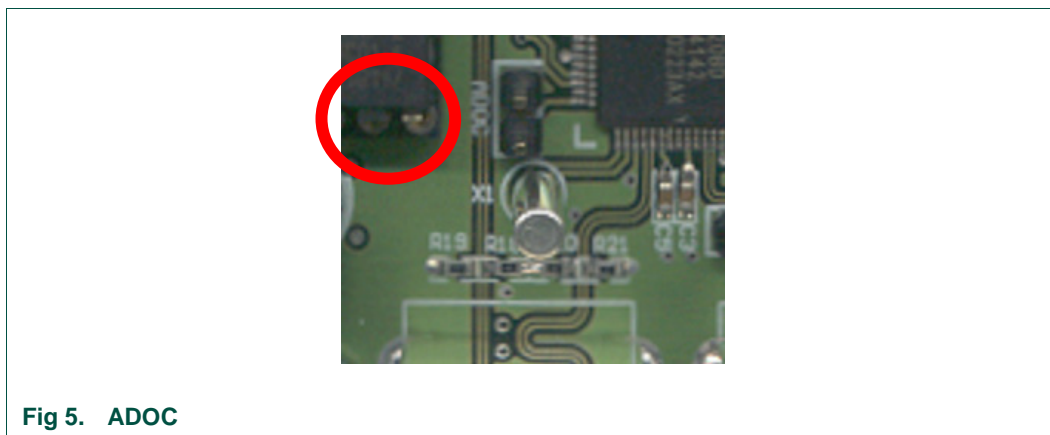

Fig 5. ADOC

5.5 Power supply

This hub demo board can be used as a self-powered USB hub. When used as a self-powered hub, use the provided power supply.

The SW1 switch sets powering mode in hub's descriptors; see [Table 4](#).



Fig 6. SW1

Table 4. Power mode selection using SW1

SW1	Power mode
S	self-powered*[1]
B	ignore

[1] *- Default settings.

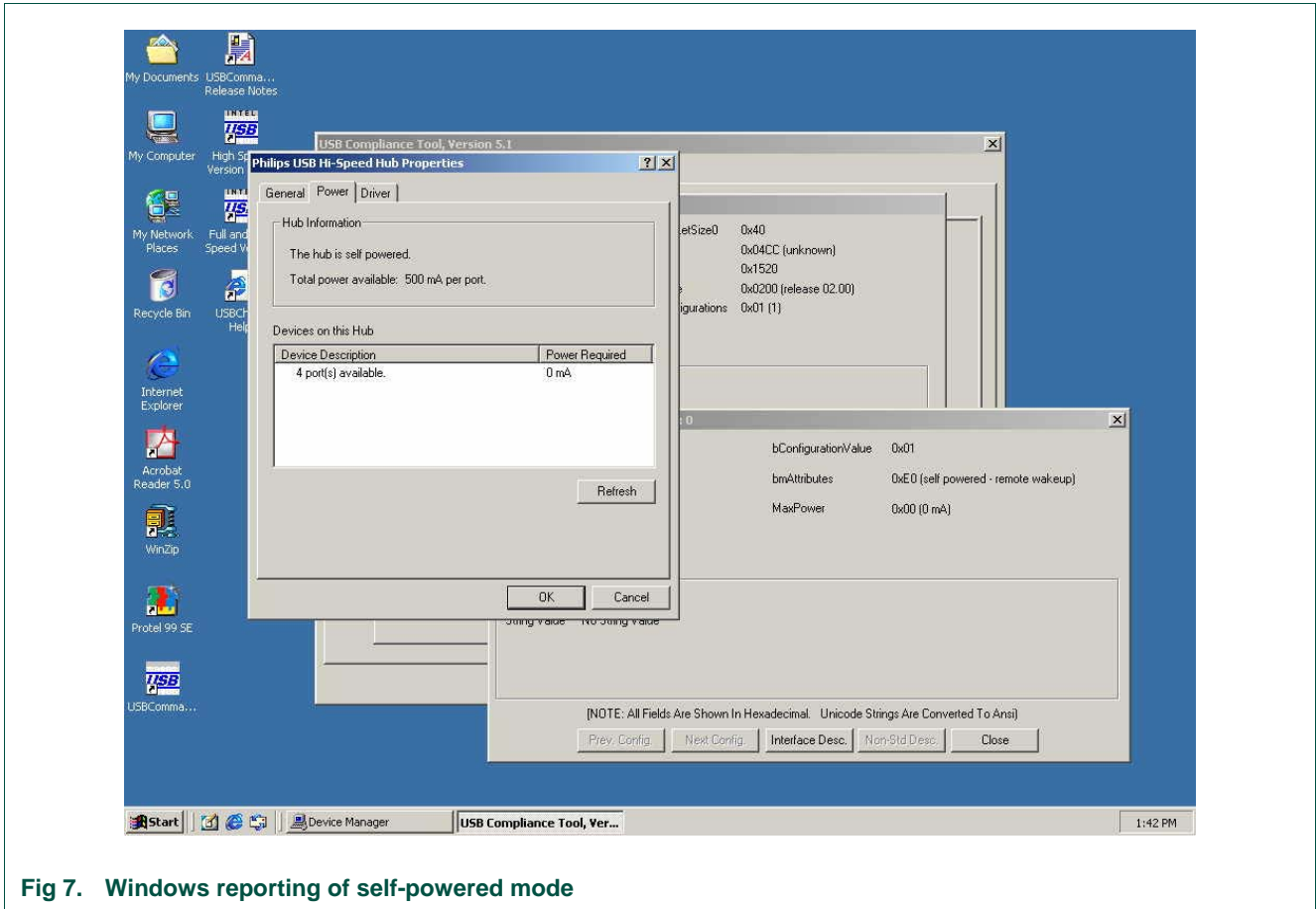

Fig 7. Windows reporting of self-powered mode

5.6 I²C-bus interface

The ISP1520 can use either its USB descriptors from the internal ROM, or from an external I²C-bus EEPROM or microcontroller. Mode selection is done using jumpers J1 and J2 (see Table 5).

Table 5. Mode selection using J1 and J2

J1	J2	Mode[1]	SCL	SDA
On	on	internal ROM	LOW	LOW
Off	off	I ² C-bus EEPROM*[1]	HIGH	HIGH

[1] *- Default settings.

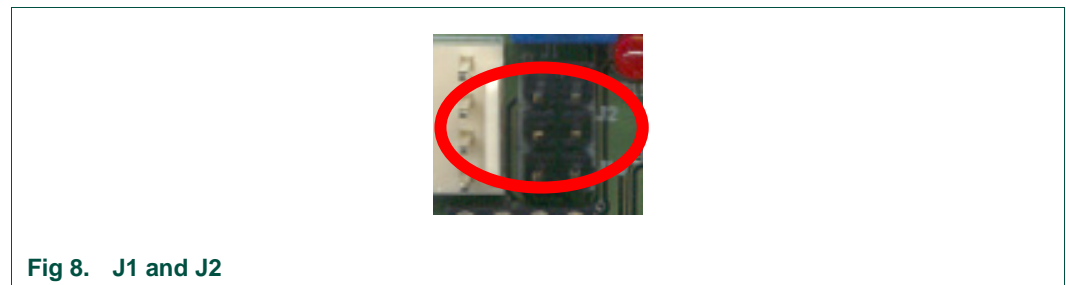

Fig 8. J1 and J2

An external I²C-bus controller acting as a master can also be used to update hub descriptors through the J42 connector.

The J10 jumper is connected to the 'Write Protect' pin of the I²C-bus EEPROM. The hub controller and the EEPROM have different I²C-bus device addresses. To program this IC on-board, select the jumper according to [Table 6](#). It is recommended that you program the I²C-bus EEPROM before connecting the hub to USB through the USB host.

For convenience, the hub demo board is equipped with a socket for this component, allowing easy programming using a universal EPROM programmer as well.

Table 6. EEPROM programming

J10	WP_N
On	write enable
Off	write protect

6. Schematics

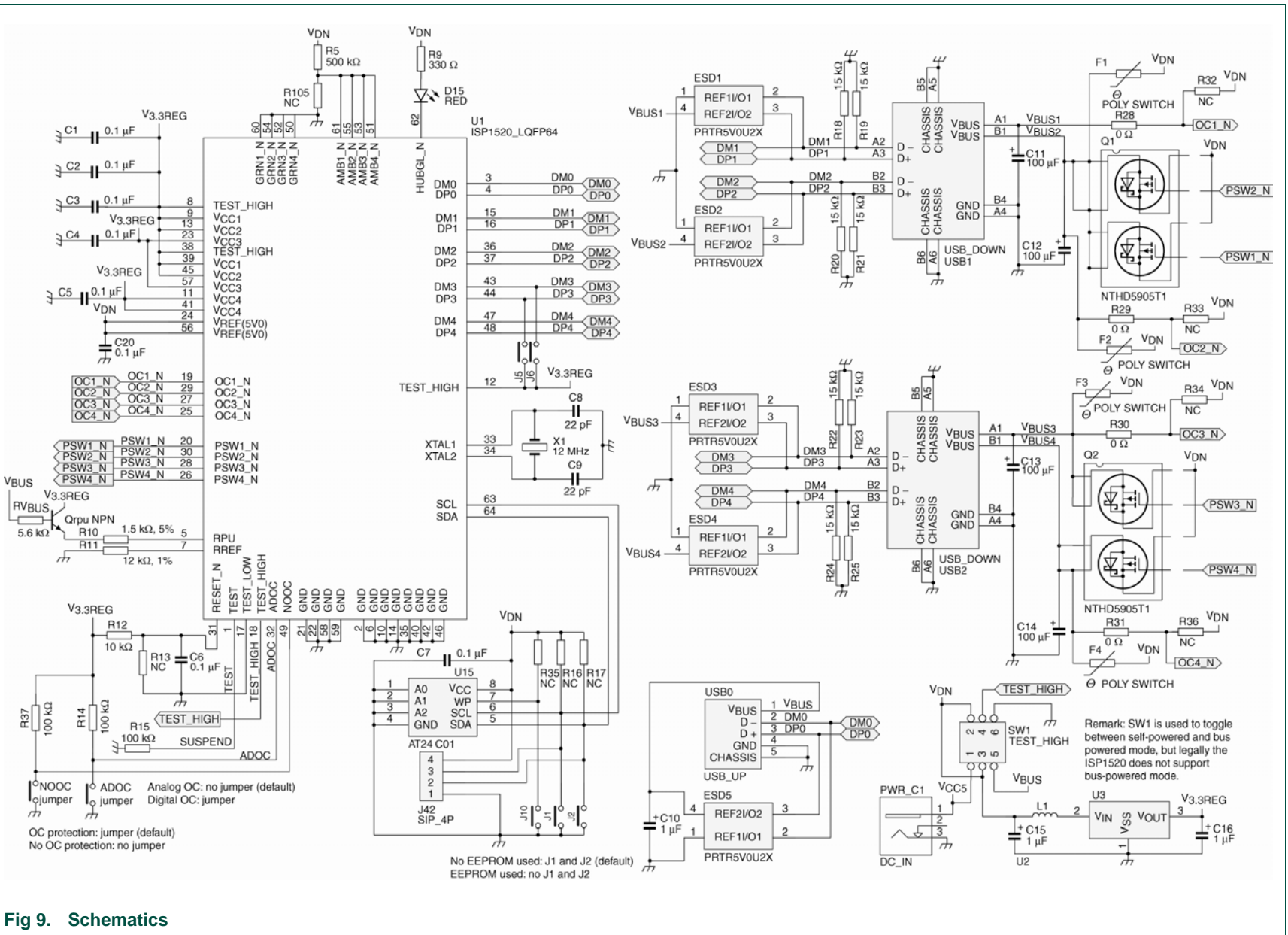

Fig 9. Schematics

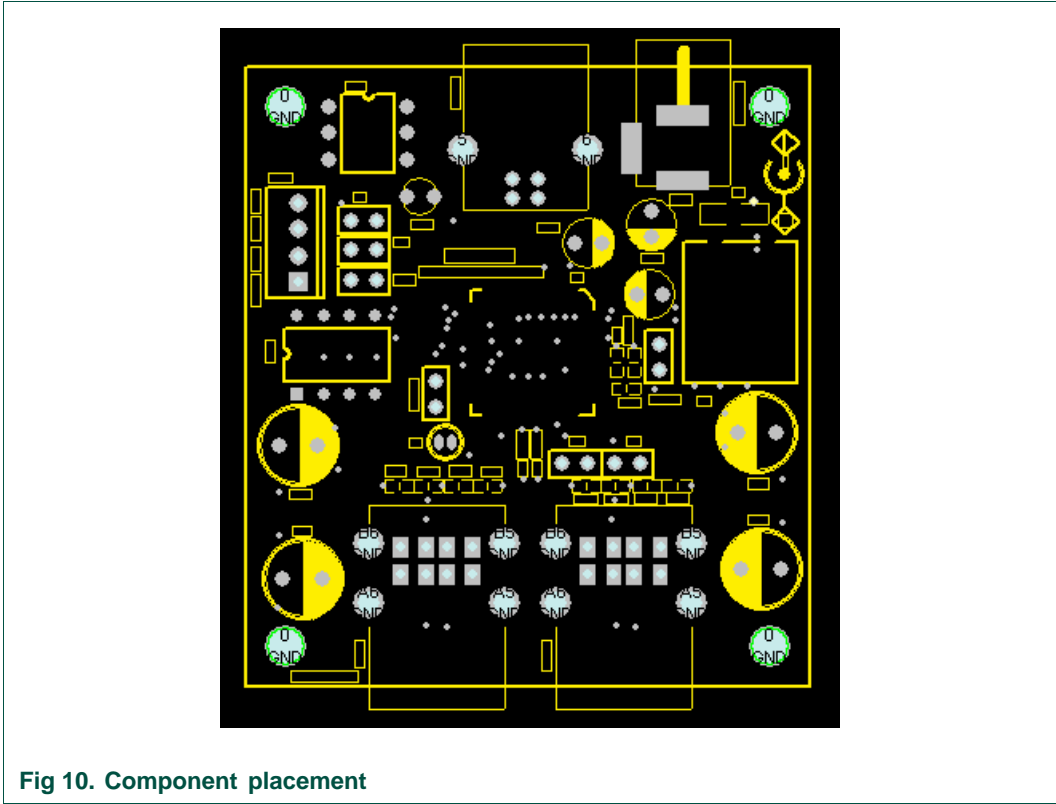

Fig 10. Component placement

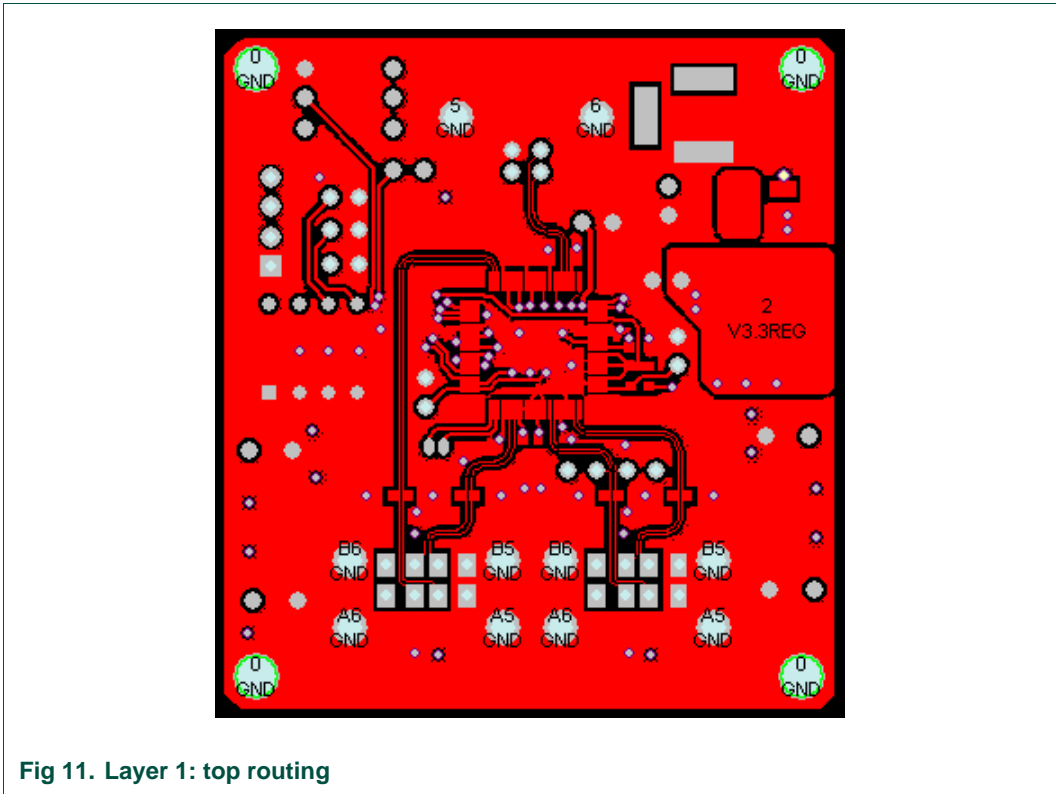
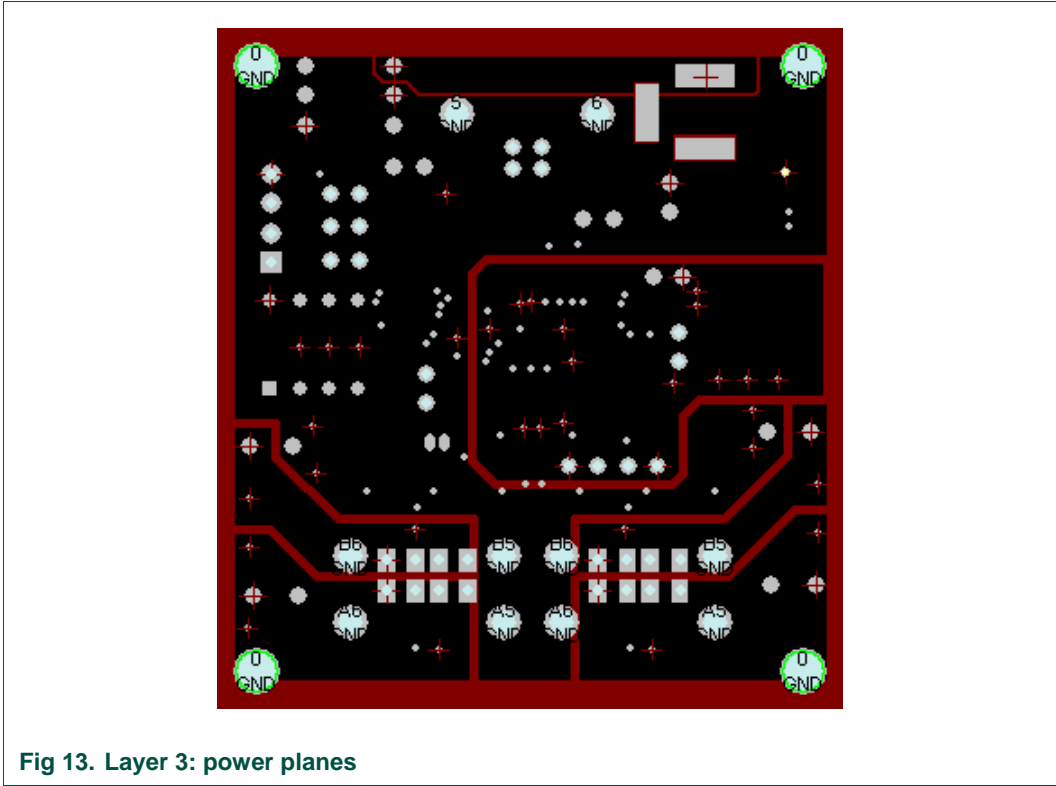
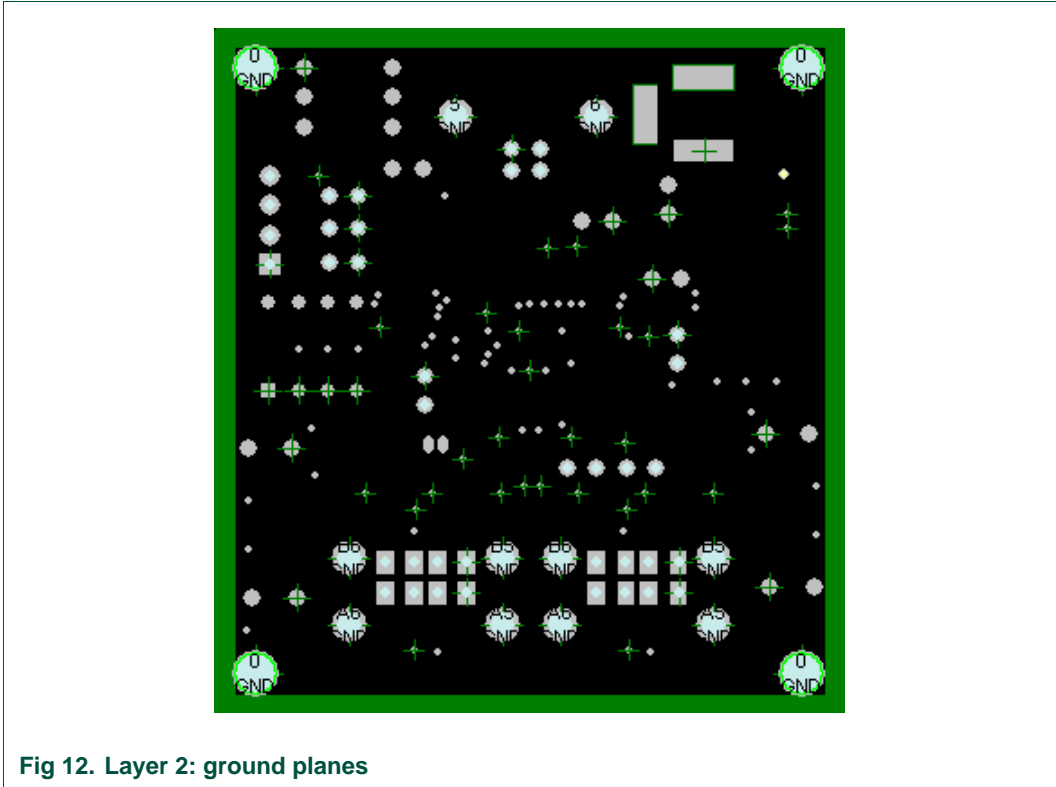
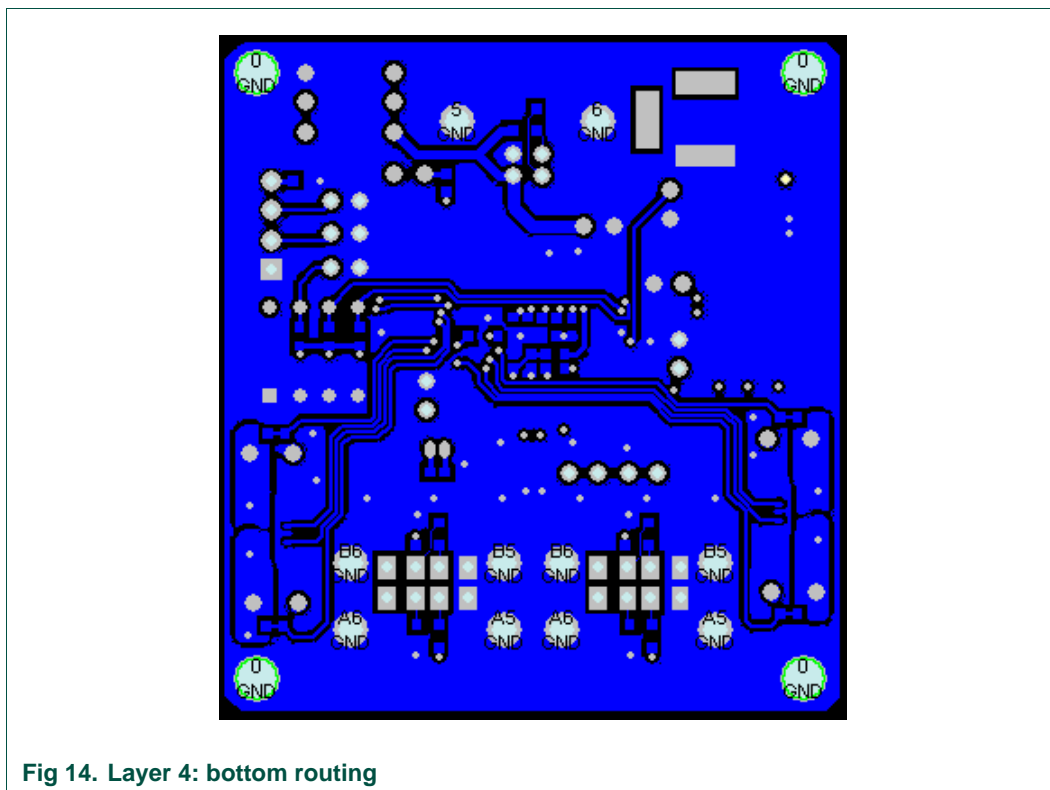

Fig 11. Layer 1: top routing





7. Installing the board

Assuming that you have already installed the USB host adapter, including drivers, on a computer running Windows, installing the hub is fairly simple.

1. Plug in power from the power supply to the hub. The power supply must meet the requirements specified in [Section 4](#).
2. Plug a USB cable in the USB0 port, and connect the other end of the cable to the USB host. After a while GoodLink LED D15 starts to blink. This indicates that the enumeration process has successfully completed and the hub is now ready for use.

You can check the driver installation in the Device Manager window. To check whether the hub is correctly installed in high-speed, select the **View-Devices by connection** command in the Device Manager window.

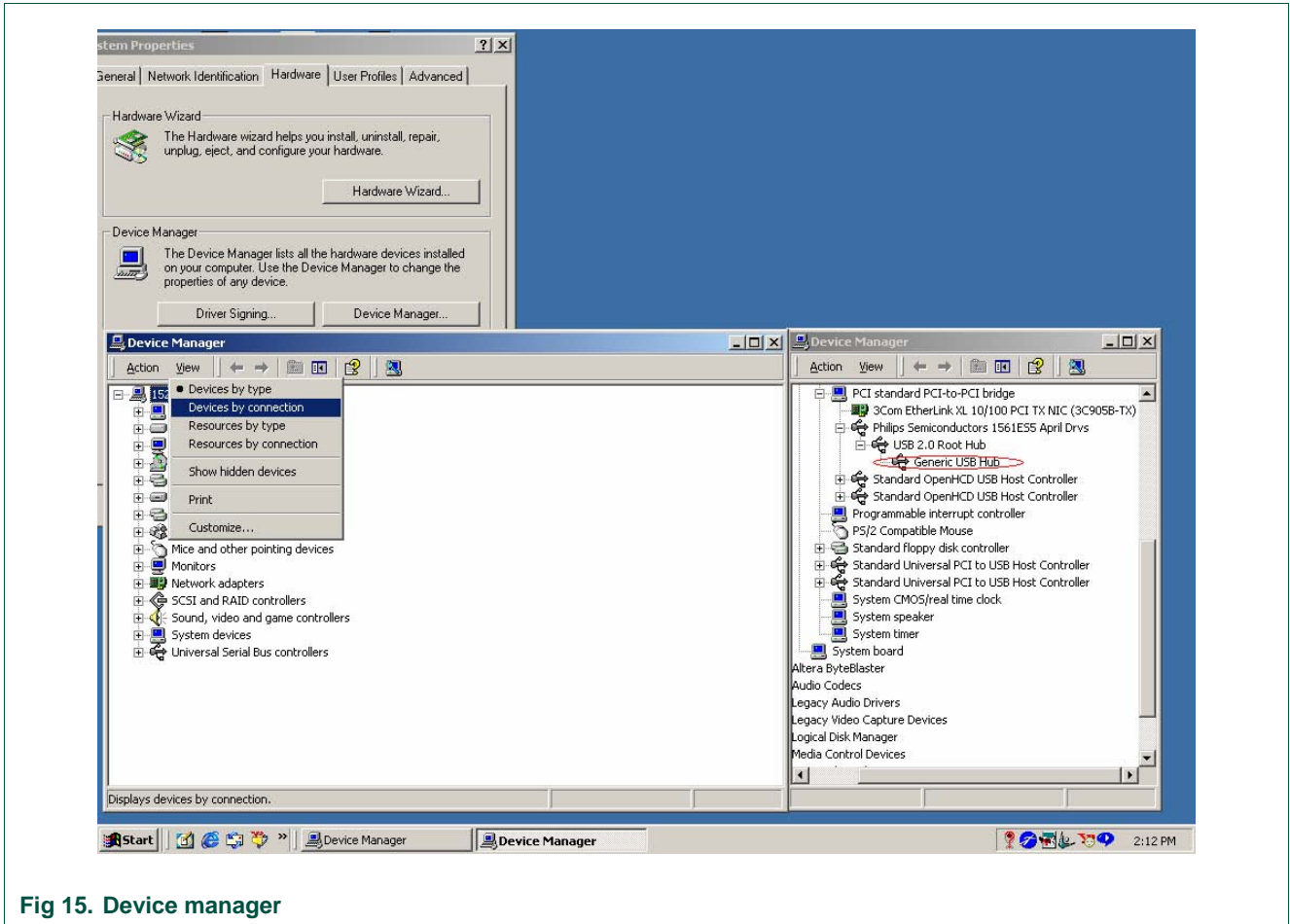

Fig 15. Device manager

3. Plug in devices at downstream facing ports.

8. Bill of materials for the hub demo board

Table 7. Bill of materials for the hub demo board

Part type	Designator	Footprint	Description
0.1 μ F	C1 C2 C3 C4 C5 C6 C7 C20	0603C	capacitor
0 Ω	R105 R32 R34 R31 R29 R30 R28 R33 R36	0603R	-
1.5 k Ω , 5 %	R10	0603R	-
1 μ F	C10	REC1-2	electrolytic capacitor
2.2 k Ω	R16 R17	0603R	-
10 k Ω	R12 R13	0603R	-
10 μ F	C15	REC1-2	electrolytic capacitor
12 k Ω , 1 %	R11	0603R	-
12 MHz	X1	XTAL7	crystal

Part type	Designator	Footprint	Description
15 kΩ	R20 R19 R18 R25 R22 R24 R23 R21	0603R	-
22 pF	C9 C8	0603C	capacitor
22 μF	C16	REC1-2	electrolytic capacitor
100 kΩ	R14 R15 R37 R5 R35	0603R	-
100 μF	C11 C14 C12 C13	REC15-3	electrolytic capacitor
330 Ω	R9	0603R	-
AT24C01	U15	DIP8	-
BLM41P600S	L1	1206CUST	-
DC_IN	PWR_C1	DC-JACK2	-
PRTR5V0U2X	ESD1 ESD2 ESD5 ESD4 ESD3	SOT-143B	ESD protection *
ISP1520_LQFP64	U1	LQFP64	-
J1	J10 J1	RAD0.1	jumper
J5	J5	RAD0.1	jumper
J6	J6	RAD0.1	jumper
J16	J2	RAD0.1	jumper
JUMPER	NOOC ADOC	RAD0.1	jumper
XC6206P302	U3	SOT89	-
NTHD5905T1	Q1 Q2	CHIPFET	logic level dual P-channel MOSFET
POLYSWITCH	F4 F2 F3 F1	POLYSWITCH	-
RED	D15	LED3	-
SIP_4P	J42	PS24254-4	connector
SP/BP#	SW1	DIP6	-
USB_DOWN	USB2 USB1	USB-TYPEA-737745	-
USB_UP	USB0	USB-TYPEB	-

9. References

- [1] Universal Serial Bus Specification Rev. 2.0
- [2] ISP1520 Hi-Speed Universal Serial Bus hub controller data sheet

10. Legal information

10.1 Definitions

Draft — The document is a draft version only. The content is still under internal review and subject to formal approval, which may result in modifications or additions. NXP Semiconductors does not give any representations or warranties as to the accuracy or completeness of information included herein and shall have no liability for the consequences of use of such information.

10.2 Disclaimers

General — Information in this document is believed to be accurate and reliable. However, NXP Semiconductors does not give any representations or warranties, expressed or implied, as to the accuracy or completeness of such information and shall have no liability for the consequences of use of such information.

Right to make changes — NXP Semiconductors reserves the right to make changes to information published in this document, including without limitation specifications and product descriptions, at any time and without notice. This document supersedes and replaces all information supplied prior to the publication hereof.

Suitability for use — NXP Semiconductors products are not designed, authorized or warranted to be suitable for use in medical, military, aircraft, space or life support equipment, nor in applications where failure or malfunction of a NXP Semiconductors product can reasonably be expected to result in personal injury, death or severe property or environmental damage. NXP Semiconductors accepts no liability for inclusion and/or use of NXP Semiconductors products in such equipment or applications and therefore such inclusion and/or use is for the customer's own risk.

Applications — Applications that are described herein for any of these products are for illustrative purposes only. NXP Semiconductors makes no representation or warranty that such applications will be suitable for the specified use without further testing or modification.

10.3 Trademarks

Notice: All referenced brands, product names, service names and trademarks are property of their respective owners.

GoodLink — is a trademark of NXP B.V.

i²C-bus — logo is a trademark of NXP B.V.

11. Contents

1.	Introduction	3
2.	ISP1520 hub demo board features.....	3
3.	System requirements.....	4
4.	Power supply adapter requirements	4
5.	Hub demo board description.....	4
5.1	ISP1520 64-pin LQFP package.....	4
5.2	GoodLink indicator	5
5.3	Port power switch transistors	5
5.4	Overcurrent circuit detection	5
5.5	Power supply.....	7
5.6	I ² C-bus interface	8
6.	Schematics	9
7.	Installing the board	13
8.	Bill of materials for the hub demo board.....	14
9.	References	15
10.	Legal information	16
10.1	Definitions	16
10.2	Disclaimers.....	16
10.3	Trademarks.....	16
11.	Contents.....	17

Please be aware that important notices concerning this document and the product(s) described herein, have been included in the section 'Legal information'.

© NXP B.V. 2007. All rights reserved.

For more information, please visit: <http://www.nxp.com>
 For sales office addresses, email to: salesaddresses@nxp.com



Date of release: 29 October 2007

Document identifier: UM10014_6