

# TEC APO 140



*"This telescope is closer to optical perfection more  
than any instrument I have ever used before."  
R.Renzi, Italy.*

**OWNER'S MANUAL  
2005**

# **IMPORTANT - PLEASE READ THIS MANUAL BEFORE USING YOUR TELESCOPE**

## **SAFETY WARNINGS**

### **Do not look at the sun through the telescope**

Viewing the sun through the telescope without special equipment (Solar Filter) will cause permanent visual impairment and telescope parts damage.

### **Do not disassemble**

Disassembly of telescope could result in personal injury and telescope malfunction.

## **CONTACT INFORMATION**

If you have any questions or need assistance - please contact us:

Phone: 303 273 9322 • Fax: 303 273 0204

E-mail: [tec@telescopengineering.com](mailto:tec@telescopengineering.com) • Web site: [www.telescopengineering.com](http://www.telescopengineering.com)

User's group site: <http://groups.yahoo.com/group/tec-scopes>

Address: Telescope Engineering Company • 15730 West 6-th Ave. Golden CO, 80401. USA

---

## **TEC APO 140 TECHNICAL SPECIFICATIONS**

Clear aperture	5.5" / 140 mm
Focal length	980 mm
Focal ratio	7.0
Image scale	3.5 arc min/mm
Resolution (theoretical)	0.8 arc sec
Focuser	Feather Touch 3545
Eyepiece holder	2" Collet type
Focusing range	4.5" / 114 mm
One turn focus travel	Coarse 21.5 mm / Fine 2.3 mm
Back focus distance	6.7" / 170 mm
Focuser load capacity	10 lb
Tube assembly diameter	5.9" / 150 mm
Baffle dia.	7" / 178 mm
TA length (shortest)	34" / 864 mm
Balance point position	14" ± 1" (350 mm ± 25 mm) from the focuser flange (fig. 5).
OTA weight	19 lb / 8.6 kg / (for tube rings - add 2 lb)
Lens coatings:	Broad band 7 layers antireflection coating (BBAR)
Price (2005)	\$4750
Includes :	Optical tube assembly, front cover, plug.

## **OPTIONAL EQUIPMENT** (see [www.telescopengineering.com](http://www.telescopengineering.com) for the current prices)

Tube rings	\$250
ScopeGuard case	\$350
Aluminum transportation case (Germany)	\$460
Finderscope bracket with base	\$120
7x50 finder (Japan)	\$120
AP finder bracket	\$60
TEC 9" dovetail plate	\$70
TEC 12" dovetail plate	\$90
Eyepiece Turret	\$500
Mahogany case for I-Turret	\$150
Field Flatteners	\$600

## OVERVIEW

This manual has been written to help you enjoy using your TEC APO 140 refractor. APO 140 has a number of features that in a given combination are rarely found in one scope:

- Precision apochromatic objective with modern coating that makes lenses almost invisible
- Retractable baffle
- Light tube assembly
- FeatherTouch 360° rotatable focuser with coarse and fine focusing
- Collet type eyepiece holder.
- Line of accessories, including:
  - Precision tube rings with adjustable latches
  - Dovetail plate (same width and fit as Losmandy plates)
  - Finder bracket with new principle of finder adjustment
  - Choice of two kind of cases.

All parts of the telescope, including: optics, coatings, etc. are made in the USA.

## GETTING TO KNOW YOUR TELESCOPE

The parts of the telescope and their functions are identified and described below.

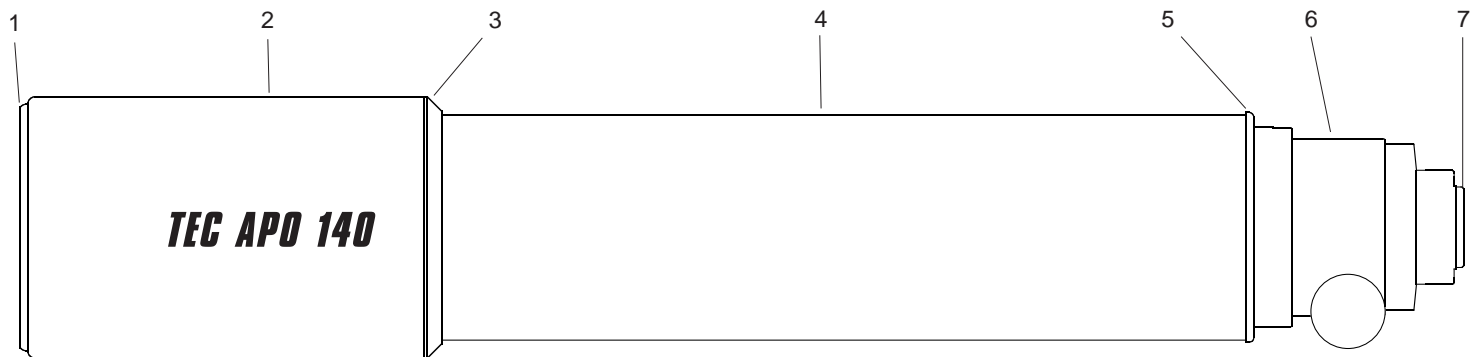

1 Front Cover. - made of Aluminum, push-pull type. It protects the optics and holds the baffle during transportation.

2 Retractable Sliding Baffle. This feature makes the OTA shorter for handling and transportation. The open end of the baffle is rounded to improve aerodynamics of the front end of telescope. Rounded edge creates less turbulence compared to straight cut baffles.

3 Baffle flange. It holds the baffle with four 4-40 Button Head Screws.

4 Tube assembly. The tube interior is coated with special light absorbent coating and has 4 sharp edge baffles, which block internal reflections.

5 OTA Focusing Mounting Flange. (It is part # 6.1 in the focuser description).

6 Focuser. See following Instructions written by Detlef Schmidt (Starlight Instruments Inc.). The focuser's tube is coated inside with the same special coating as the tube assembly.

7 Plug. It is a small part that keeps the focuser end closed.



*To remove cover put thumb and index fingers into the sliding latches and move them in the shown directions.*

# FEATHER TOUCH FOCUSER MODEL 3545

## Care and use of the Feather Touch 3545

The Feather Touch 3545 was a collaboration design effort between Telescope Engineering Co. and Starlight Instruments for TEC's line of fine refractors. It was designed to provide the user with the best possible control while focusing using a 9:1 fine focus reduction assembly along with other features that make the use of the telescope simple and functional. All efforts were taken to design it with the best available materials and technology to achieve long-lasting functionality and reliability.

### Part Description

- 6.1 OTA Focuser Mounting Flange
- 6.2 Focuser Locking Collar
- 6.3 Locking Collar Stems
- 6.5 Tension Adjustment Screw
- 6.6 Finder Base Screw Holes (Plugged with (2), 8-32 Button Head Screws)
- 6.7 Focuser Housing
- 6.8 Coarse Focus Knobs
- 6.9 Fine Focus Knob
- 6.10 Draw Tube with mm scale
- 6.11 Stainless Steel Wear Strips
- 6.12 Draw Tube End Cap
- 6.13 Draw Tube End Cap Locking Screws
- 6.14 Eyepiece Collet Locking Nut
- 6.15 Eyepiece Collet Sleeve (not shown being under the plug (fig. 7)).

### Description of Design Features

1. The Feather Touch 3545 achieves excellent focusing capability using a 9:1 Planetary Reduction Assembly coupled to a fine focus knob (fig. 6.9). The fine focus knob should be used once the image is close to focus and final tweaking is required.

2. The two coarse focusing knobs (fig. 6.8) on each side of the focuser allow quick rough positioning of the eyepiece or imaging equipment. They are coupled to the rack and pinion set and the fine focus knob.

3. The assembly incorporating the focusing knobs, the pinion and its housing is called the pinion assembly (not shown). This assembly is attached to the focuser housing using (2) 6-32 socket head cap screws. The position of the pinion assembly relative to the rack, is precisely adjusted by Starlight Instruments using 4 flat bottom set screws (internal to the pinion assembly) to provide the minimum amount of backlash between the rack and the pinion for ease of operation. The other adjustment that is made is to align the pinion axis to be parallel to the rack face.

**NOTE: It is possible to reverse the pinion assembly for left handed preference but Starlight Instruments does not recommend the user reversing this assembly because of possible misalignment resulting in a loss of performance or possible damage. Please contact Starlight Instruments or TEC if this change is desired.**

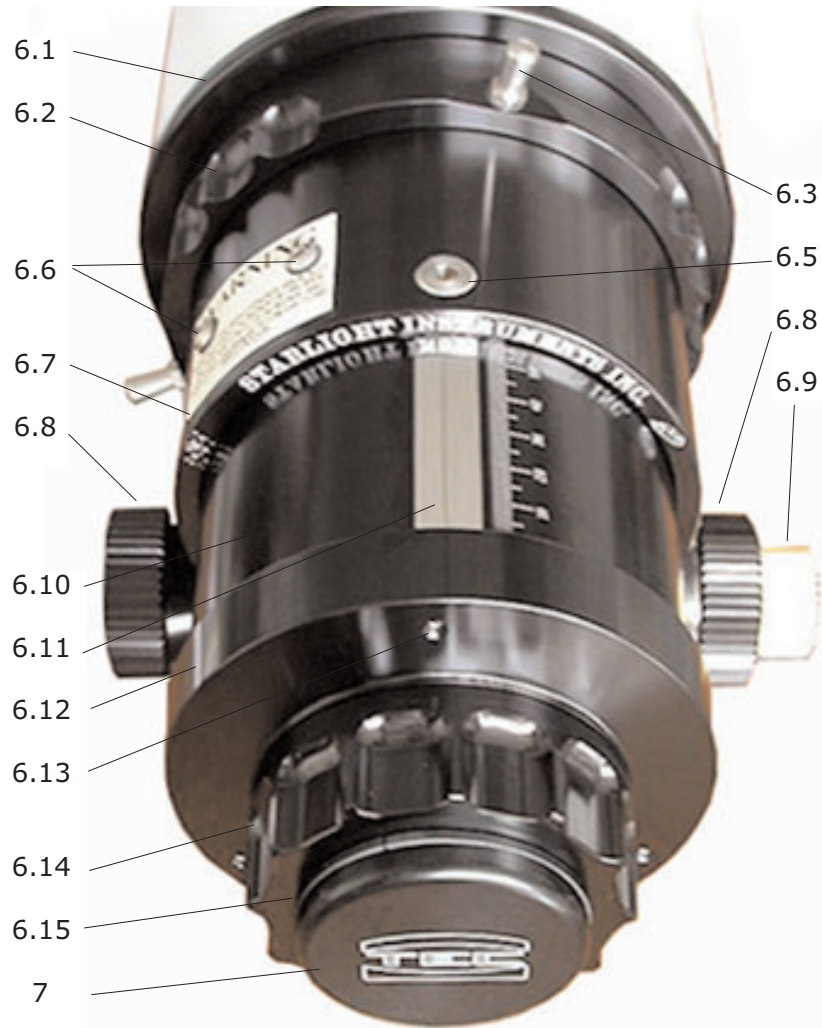

4. The Feather Touch 3545 focuser is assembled to the OTA via the Focuser Mounting Flange (fig. 6.1), and the Focuser Locking Collar (fig. 6.2). Loosening the focuser Locking Collar allows the focuser to be rotated to any position relative to the telescope for ease of use. Once the focuser has been positioned, it can be locked by turning the Locking Collar by either grabbing the grooves on this collar or by grabbing the optional Locking Stems and rotating the Locking Collar clockwise until it is tight. The Locking Stems help to provide a better grip for tightening the collar. They can however be replaced with the 10-32 Button Head Cap Screws for a cleaner look if that is desired. NOTE: The focuser can be removed by loosening the Locking Collar and unscrewing it completely and then pulling the focuser from the Adapter Flange. This should only be done in rare circumstances and after contacting Starlight Instruments or TEC because of possible damage that may result.

5. The Draw Tube (fig. 6.10) is fitted with 3 Stainless Steel wear strips (fig. 6.11). These strips provide very low friction between the Housing (fig. 6.7) and the Draw Tube (fig. 6.10). There is no lubrication required on these parts and an occasional cleaning of the Draw Tube and the Stainless Steel Wear Strips with a damp paper towel to remove any grit or dirt is advisable. The design is such, that as the focuser is racked in and out, the wiping action of the Wear Strips on the mating surfaces tends to be self-cleaning.

6. The drag between the Focuser Housing (fig. 6.7) and the Draw Tube (fig. 6.10) can be adjusted in using two adjustment methods. The Tension Adjustment Screw can be adjusted using a 3/16 inch Allen wrench. Only a slight amount of rotation on this screw makes a notable difference. Tightening this screw will allow larger loads to be lifted without the focuser moving from the dead weight that may be attached to it and it will also decrease the amount of deflection during positional changes during long exposures. Generally the factory settings should be sufficient for most applications.

In addition, adjustment can be done in a simpler way - by tightening a thumb screw (not shown in picture, but easy to find) under the pinion assembly.

7. In the event that different equipment such as: an optional Field Flattener or AP 2.7" threaded End Cap (available from Starlight Instruments) is needed at the end of the focuser, the Draw Tube End Cap (fig. 6.12) can be removed by loosening the (3) 6-32 socket head set screw and then unscrewing the back.

8. The 2 inch Eyepiece Holder does not use traditional thumb screws. This focuser uses an Eyepiece Collet Locking Nut (fig. 6.14) and an Eyepiece Collet Sleeve. This design assures that the eyepiece or imaging equipment is always precisely positioned and held into place during imaging. To secure your eyepiece, insert the eyepiece into the 2 inch opening making sure that the nut has been turned counter clock wise to open the collet sleeve and push in the eyepiece. Tighten the Collet Nut clockwise until it is tight.

**WARNING: Failure to tighten the Collet Nut can result in personal injury and/or damage to equipment. Always make sure that the eyepiece is secured properly during use.**

**WARNING: Never point to the sun without proper filtering or without the Front Cover in place. Failure to do so can result in personal injury or damage to the collet locking sleeve and/or optics. The Collet Locking Sleeve is plastic and can melt if it gets too hot. Possible fumes during melting can cause fogging or damage to the optics.**

9. If a finder base is to be attached to the focuser housing make sure that the screws being used are the proper length.

**WARNING: If they are too long they will contact the draw tube thereby causing damage to the anodized surface of the draw tube.**

## **WARRANTY**

Starlight Instruments Incorporated guarantees this product to be free of any defects in material or workmanship for 3 years to the original owner. Disassembly of focuser outside of the described items voids all warranties.

Starlight Instruments Inc. • P.O. Box 68282, Schaumburg, IL 60168-0282. USA.  
Phone: 847-985-9595.

# OPTICS

APO140 is an Aplanatic Oiled Triplet refractor with ED glass (FPL-53) as a middle element. The color correction is optimized for visual use with focus shift less than 0.02% from 436nm to 1000nm. Calculated Strehl for e-line (546nm) is 0.99.

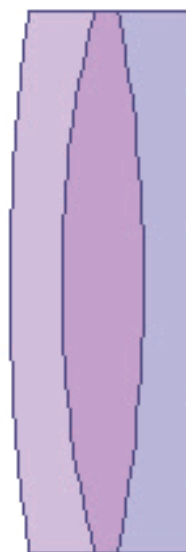
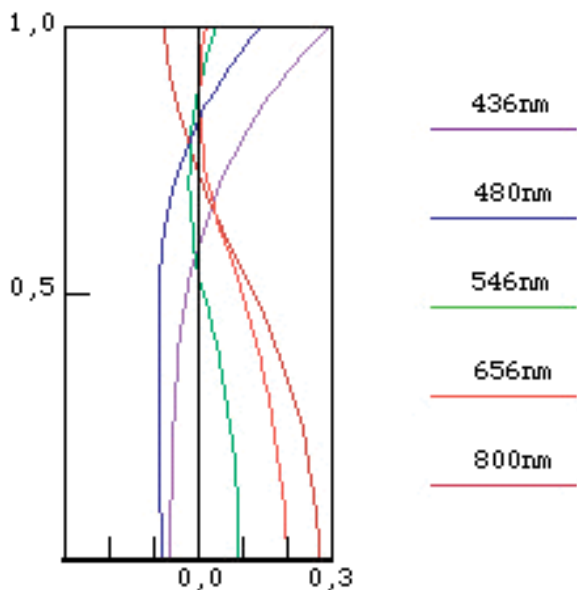

Interferometry of the first run lenses showed that the average Strehl is close to calculated with a very smooth wave front and RMS less than 1/50.

The oiled design has only two air-to-glass surfaces. The result is a higher contrast image because of much less scatter and veiling glare due to internal reflections comparing to air-spaced objectives.

The outside surfaces of front and rear lenses are coated with 7 layers of antireflective coating, that reduce light reflection to the average 0.25% in range of 400-700nm.

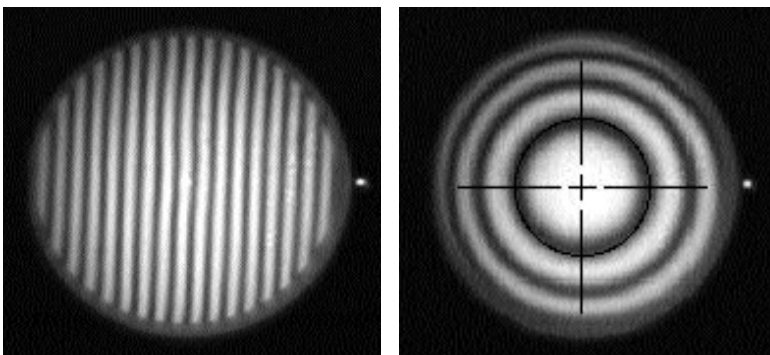

Shown on the left is a sample of interferometry of typical objective with appr. RMS less than 1/50 and wave front error less than 1/10. The lenses are tested during manufacturing with different methods including: test

plates, autocollimation test with an artificial star, interferometry, **however we do not supply test results to avoid any kind of misinterpretations or "numbers" competition between customers.**

Each objective assembled in precision thermocompensation cell (1), that contains: Three Lenses Sealed Construction (2) with a special oil between lenses and Threaded Ring (3). The Threaded Ring of each objective is engraved with serial number of OTA. The optics are collimated at the shop during assembly and do not require any additional adjustments. Collimating, assembling and sealing require special equipment and techniques and must be done only by qualified technician.



**WARNING: NEVER TRY TO DISASSEMBLE THE OBJECTIVE! DISSASSEMBLY OF THE OBJECTIVE WILL RESULT IN SERIOUS DAMAGE TO THE MOST EXPENSIVE PART OF YOUR TELESCOPE - THE OPTICS!**

# ACCESSORIES

## TUBE RINGS

CNC machined, black anodized aluminum, compact and lightweight design with stainless steel latches (set of two rings weights 750g). Ring dimensions and hole pattern are shown in the sketch below. Each ring contains: Upper Base (1); Latch (2); and Lower Base (3). Latches for the scopes of the third and fourth run are adjustable. The screw (5) has a Phillips type head for easy adjustment, the small nut (4) will hold screw in place after adjustment. Rings can be attached to the mount with either TEC Dovetail plate, AP or Losmandy plates. **NOTE:** From user feedback - it is better and more safe to keep rings on the OTA all the time if possible - this way there is no chance

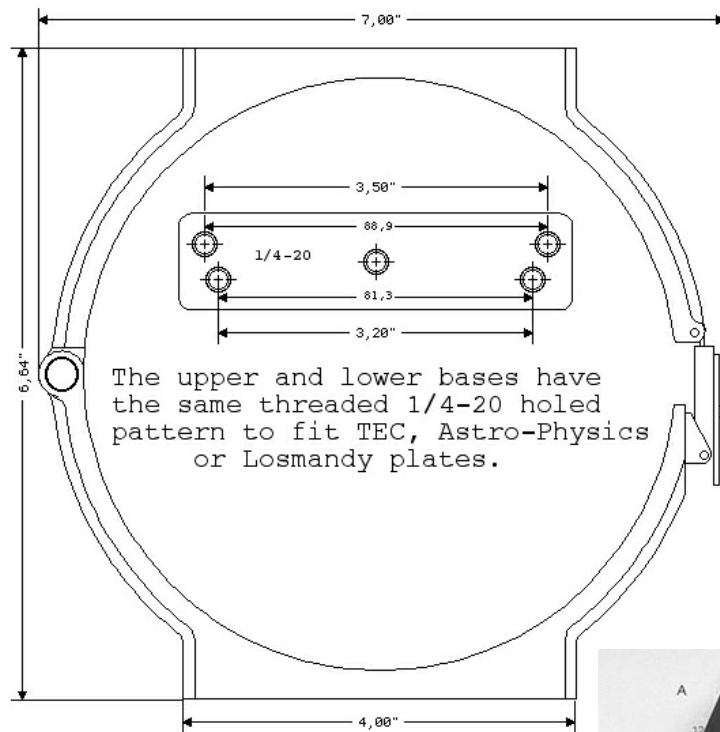
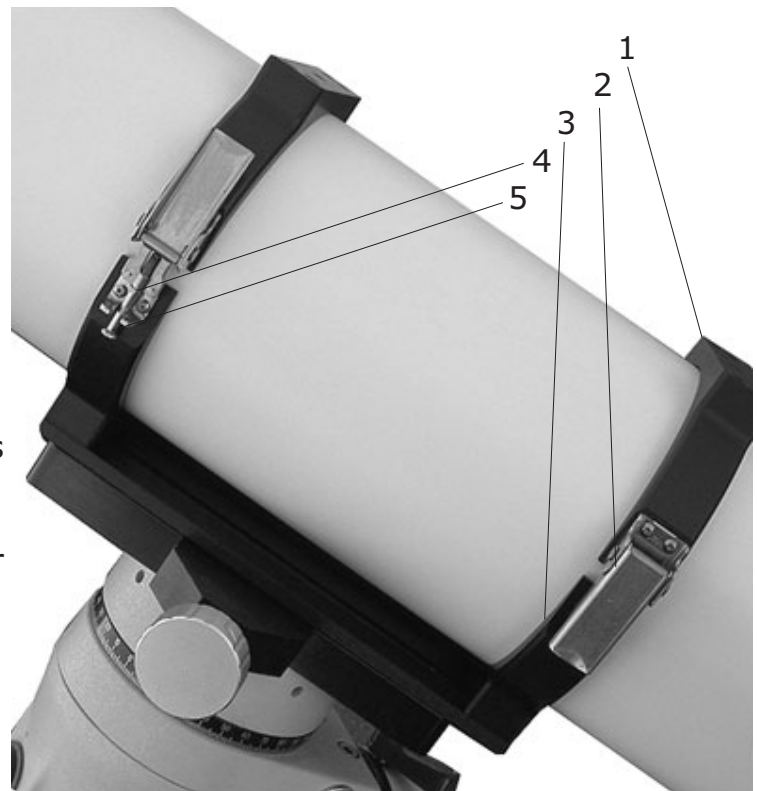

for scratching the tube.

## DOVETAIL PLATE

The Dovetail Plate, like all other accessories for this telescope, is CNC machined for lightness (320g) and rigidity from aluminum stock, and then black anodized for a tough, corrosion-free surface.

Though having the same width and hole pattern as Losmandy plates, the TEC Dovetail Plate is only 9" long. The shorter length not only allows it to be lighter, but also provides you the convenience of being able to retract the Front baffle (for storage) without having to move the

OTA inside the rings, as would be the case if longer plates were being used.

The TEC Dovetail Plate is compatible with Losmandy, WYO or Casady Saddle systems. Two 8-32 security screws must be installed on each end of the Plate; these security screws prevent the dovetail and OTA from accidentally slipping off the dovetail holder.

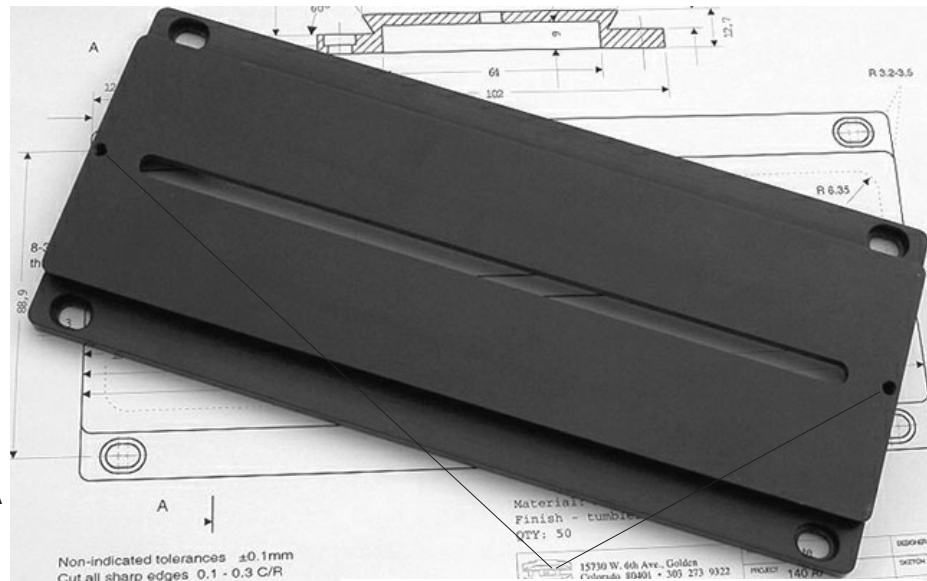

8-32 threaded holes for security screws

## TEC FINDERSCOPE BRACKET

The TEC Finderscope Bracket is designed to hold a traditional 50mm optical finder or a Red Dot sight.

This new design requires only 2 thumb screws for alignment. It looks and works in a much more elegant way.

The Finderscope Bracket contains the following parts: Finder Base (1), that attaches to the focuser with two 8-32 screws; Holding Knob (2), tightening this knob will hold the Finder Arm (3) with Finder Holder (4) to the Finder Base. The Finder (9) is spring-loaded with spring and screw covered by

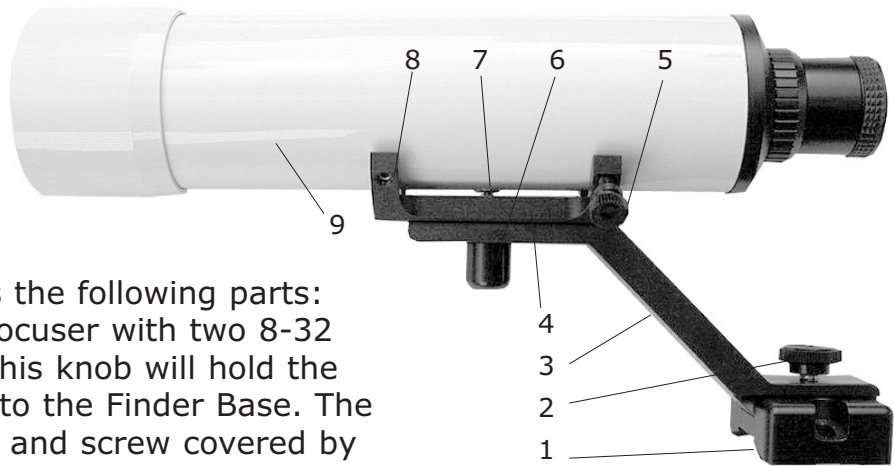

Spring Cover (6). The Finder holder has two 10-32 set screws (8) on the objective side and two 10-32 Alignment Thumb Screws (5). A special insert (7) must be installed in the finder's body. TEC performs this installation for free in any brands. Please note that finder's diameter should not be larger than 2".

When attaching the finder base to the focuser housing make sure to use screws of the proper length.



Finder base



### WARNING:

**If the screws are too long, they will contact the draw tube and damage its anodized surface !**

Shown on above picture is the Astro-Physics Finder bracket with Orion 9x50 finder. This combination is less expensive and does not require insert installation.

The Red Dot sights could also be installed. This installation requires fewer parts: only a Finder Base and a Finder Arm with knob.







## TELESCOPE CASES

After you have finished observing and are looking for a safe place to store your telescope, the best place would be a case. We have two types available:

**Scopeguard Case** shown on the left - a foam-fitted carrying case that will keep your scope in the best condition for years. You can even keep the Tube rings and plate on the OTA - this set up fits in the Case.

The second case, shown below, is Aluminum transportation case made in Germany. It has hard foam interior with a few special sections that allow to hold the APO140 with rings, plate and Finder with

bracket (without removing it). 2" AP diagonal, 5 of 2" eyepieces. Dimensions of AL case are: 10" x 13.5" x 37". Weight (net) -13lb. Weight with scope, rings, plate, finder+ bracket, AP diagonal, 2" eyepieces appr. - 40lb.



## ACCESSORIES:

**Eyepiece Turret** with Mahogany case. Precision holder for five 1.25" eyepieces. Diagonal mirror made of Sitall or Quartz. Case safely holds six 1.25" eyepieces and I-Turret. Case dimensions: 5.5" x 8.25" x 10.75"; weight - 2lb. This new component will let you change your favourite eyepieces very fast - just click from one to the next one and enjoy observing.



Latest updates for this manual or new accessories are available on our web: [www.telescopengineering.com](http://www.telescopengineering.com) and on TEC-scopes users group: <http://groups.yahoo.com/group/tec-scopes>.

# FOCUSING DIAGRAM

Focusing tube is completely "IN"  
Unvignetted field dia. ~1.0"

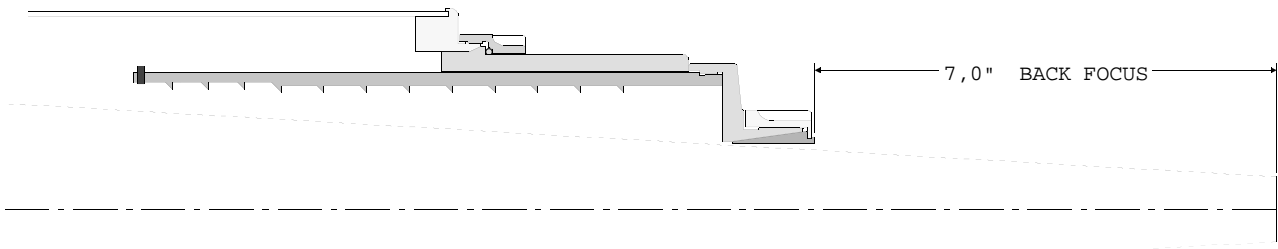

Focusing tube is completely "OUT"  
Unvignetted field dia. ~1.6"  
3" long extension tube is required  
for straight through viewing

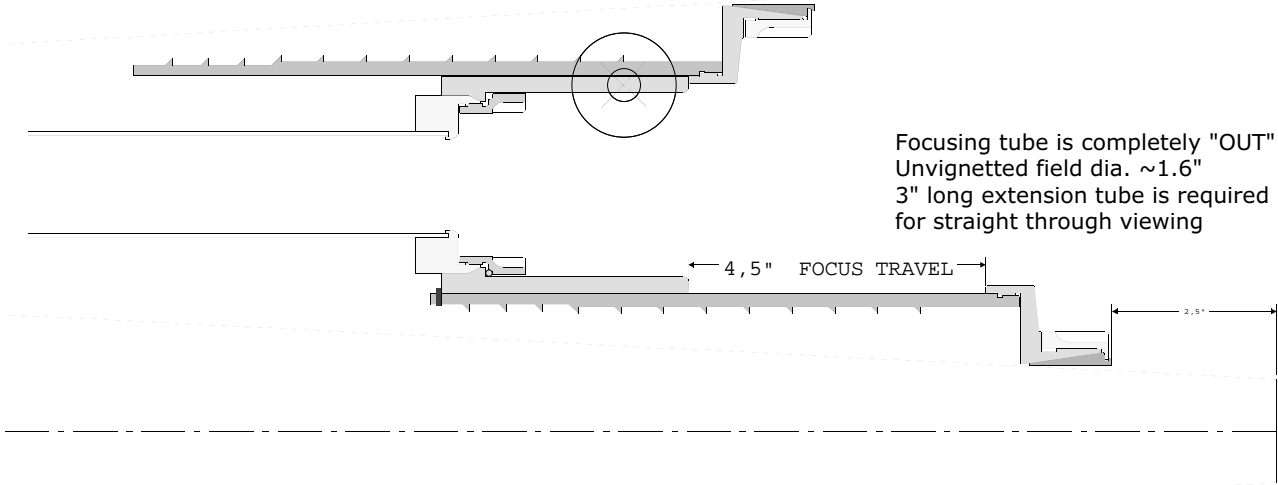

With the 2" diagonal focusing tube is in the middle position  
Unvignetted field dia. ~1.4"

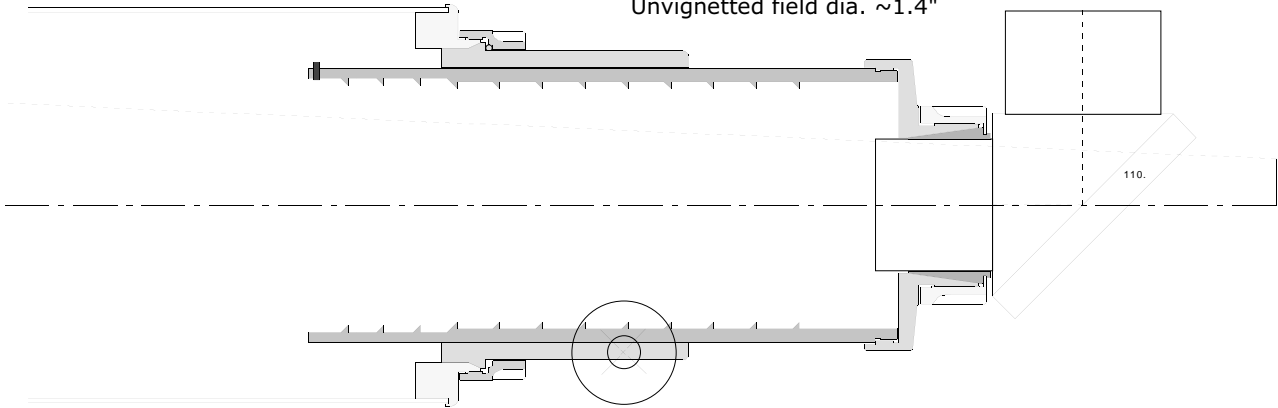

With the Field Flattener focusing tube is in the middle position  
Unvignetted field dia. ~2.4"

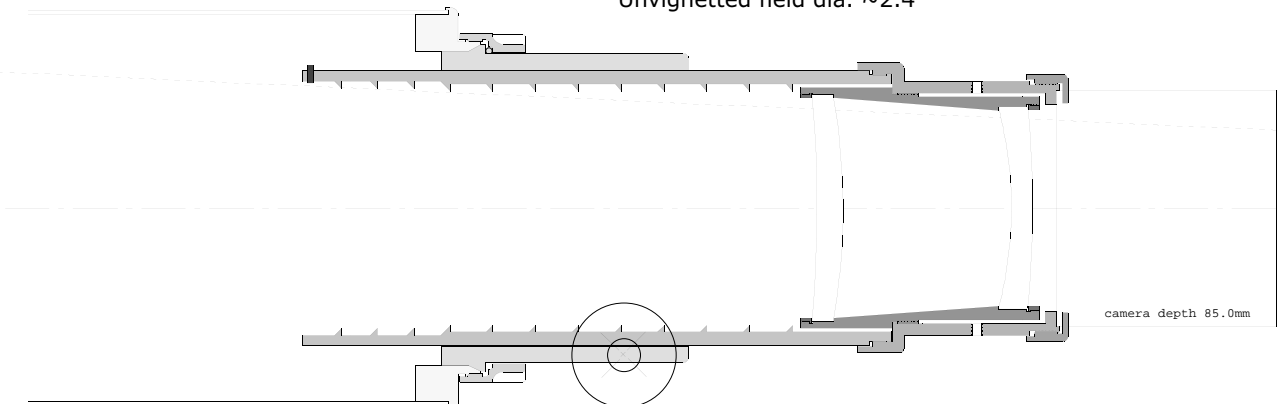

## Cleaning :

The tube assembly and front baffle are powder coated, to clean them use water with a soap or mineral spirits (paint thinner); do not use Acetone or other strong chemicals. Please contact us if you need the lens to be cleaned.

## Handling :

Handling telescope around and it's transportation to the observing site requires careful handling.

*If you find any problems, or have any comments - please call us for assistance.  
Telescope Engineering Company is committed to serving it's  
customers after sale for unlimited time.*

*Yuri Petrunin, TEC President.*

## TEC APO140 UPDATES

	RUN I (2002)	RUN II (2003)	RUN III (2004)	RUN IV (2005)
QTY plan/made	40/35	40/40	>100	>100
OTA price	\$4000	\$4250	\$4600	\$4750
Tube dia.	152.4mm	152.4mm	150.1mm	150.1mm
OTA weight	18 lb	18 lb	18.5 lb	18.5 lb
Tube type	drawn	drawn	machined	machined
Labeling	no	yes	yes	yes
Color OTA / Baffle	white/black	white/white	white/white	white/white
Internal paint	ultra flat black / spray	ultra flat black / spray	special coating	special coating
Internal baffles	3	4	4	4
Rings latches	fixed	fixed	adjustable	adjustable
Cover / material / style	Plastic / screw-type	Plastic / screw-type	Al / push-pull	Al / push-pull

*"A virtually perfect textbook image both in and out of focus. This is my first time to experience such perfection in this regard. My subjective evaluation put the optics at 1/8 to 1/16th wave..." M.T., Japan.*