

# OPERATOR'S MANUAL

3 in. x 21 in. BELT SANDER

VARIABLE SPEED  
DOUBLE INSULATED

R2720

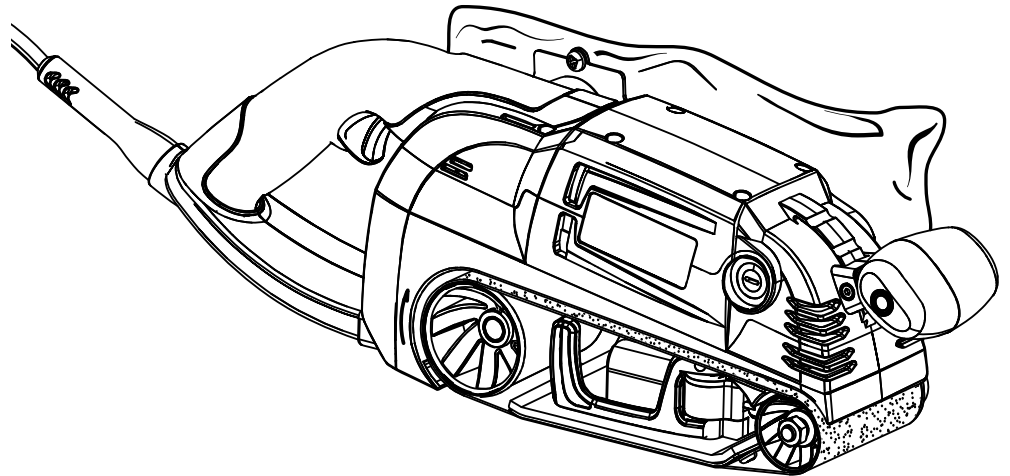

Your belt sander has been engineered and manufactured to our high standard for dependability, ease of operation, and operator safety. When properly cared for, it will give you years of rugged, trouble-free performance.

---

**⚠ WARNING:**

To reduce the risk of injury, the user must read and understand the operator's manual before using this product.

---

Thank you for buying a RIDGID product.

**SAVE THIS MANUAL FOR FUTURE REFERENCE**

# TABLE OF CONTENTS

---

- Introduction ..... 2
- General Safety Rules ..... 3-4
- Specific Safety Rules ..... 4
- Symbols ..... 5-6
- Electrical ..... 7
- Features ..... 8-9
- Assembly ..... 9
- Operation ..... 10-15
- Maintenance ..... 16-17
- Warranty ..... 19
- Parts Ordering / Service ..... 20

# INTRODUCTION

---

This tool has many features for making its use more pleasant and enjoyable. Safety, performance, and dependability have been given top priority in the design of this product making it easy to maintain and operate.

# GENERAL SAFETY RULES

---

## **WARNING:**

**Read all instructions.** Failure to follow all instructions listed below, may result in electric shock, fire and/or serious injury. The term “power tool” in all of the warnings listed below refers to your mains-operated (corded) power tool or battery-operated (cordless) power tool.

---

## **SAVE THESE INSTRUCTIONS**

### **WORK AREA SAFETY**

- **Keep work area clean and well lit.** Cluttered or dark areas invite accidents.
- **Do not operate power tools in explosive atmospheres, such as in the presence of flammable liquids, gases, or dust.** Power tools create sparks which may ignite the dust or fumes.
- **Keep children and bystanders away while operating a power tool.** Distractions can cause you to lose control.

### **ELECTRICAL SAFETY**

- **Power tool plugs must match the outlet. Never modify the plug in any way. Do not use any adapter plugs with earthed (grounded) power tools.** Unmodified plugs and matching outlets will reduce risk of electric shock.
- **Avoid body contact with earthed or grounded surfaces such as pipes, radiators, ranges and refrigerators.** There is an increased risk of electric shock if your body is earthed or grounded.
- **Do not expose power tools to rain or wet conditions.** Water entering a power tool will increase the risk of electric shock.
- **Do not abuse the cord. Never use the cord for carrying, pulling or unplugging the power tool. Keep cord away from heat, oil, sharp edges, or moving parts.** Damaged or entangled cords increase the risk of electric shock.
- **When operating a power tool outdoors, use an extension cord suitable for outdoor use.** Use of a cord suitable for outdoor use reduces the risk of electric shock.

### **PERSONAL SAFETY**

- **Stay alert, watch what you are doing and use common sense when operating a power tool. Do not use a power tool while you are tired or under the influence of drugs, alcohol or medication.** A moment of inattention while operating power tools may result in serious personal injury.
- **Use safety equipment. Always wear eye protection.** Safety equipment such as dust mask, non-skid safety shoes, hard hat, or hearing protection used for appropriate conditions will reduce personal injuries.
- **Avoid accidental starting. Ensure the switch is in the off-position before plugging in.** Carrying power tools with your finger on the switch or plugging in power tools that have the switch on invites accidents.

- **Remove any adjusting key or wrench before turning the power tool on.** A wrench or a key left attached to a rotating part of the power tool may result in personal injury.
- **Do not overreach. Keep proper footing and balance at all times.** This enables better control of the power tool in unexpected situations.
- **Dress properly. Do not wear loose clothing or jewelry. Keep your hair, clothing, and gloves away from moving parts.** Loose clothes, jewelry, or long hair can be caught in moving parts.
- **If devices are provided for the connection of dust extraction and collection facilities, ensure these are connected and properly used.** Use of these devices can reduce dust-related hazards.
- **Do not wear loose clothing or jewelry. Contain long hair.** Loose clothes, jewelry, or long hair can be drawn into air vents.
- **Do not use on a ladder or unstable support.** Stable footing on a solid surface enables better control of the tool in unexpected situations.

### **POWER TOOL USE AND CARE**

- **Do not force the power tool. Use the correct power tool for your application.** The correct power tool will do the job better and safer at the rate for which it was designed.
- **Do not use the power tool if the switch does not turn it on and off.** Any power tool that cannot be controlled with the switch is dangerous and must be repaired.
- **Disconnect the plug from the power source and/or the battery pack from the power tool before making any adjustments, changing accessories, or storing power tools.** Such preventive safety measures reduce the risk of starting the power tool accidentally.
- **Store idle power tools out of the reach of children and do not allow persons unfamiliar with the power tool or these instructions to operate the power tool.** Power tools are dangerous in the hands of untrained users.
- **Maintain power tools. Check for misalignment or binding of moving parts, breakage of parts, and any other condition that may affect the power tool’s operation. If damaged, have the power tool repaired before use.** Many accidents are caused by poorly maintained power tools.
- **Keep cutting tools sharp and clean.** Properly maintained cutting tools with sharp cutting edges are less likely to bind and are easier to control.
- **Use the power tool, accessories and tool bits etc., in accordance with these instructions and in the manner intended for the particular type of power tool, taking into account the working conditions and the work to be performed.** Use of the power tool for operations different from those intended could result in a hazardous situation.

# GENERAL SAFETY RULES

---

## SERVICE

- **Have your power tool serviced by a qualified repair person using only identical replacement parts.** This will ensure that the safety of the power tool is maintained.
- **When servicing a power tool, use only identical replacement parts. Follow instructions in the Maintenance section of this manual.** Use of unauthorized parts or failure to follow Maintenance instructions may create a risk of shock or injury.



## WARNING!

To reduce risk of injury, user must read instruction manual.

---

## SPECIFIC SAFETY RULES

---

- **Hold power tool by insulated gripping surfaces when performing an operation where the cutting tool may contact hidden wiring or its own cord.** Contact with a “live” wire will make exposed metal parts of the cutting tool “live” and shock the operator.
- **Know your power tool. Read operator’s manual carefully. Learn its applications and limitations, as well as the specific potential hazards related to this power tool.** Following this rule will reduce the risk of electric shock, fire, or serious injury.
- **Always wear safety glasses. Everyday eyeglasses have only impact-resistant lenses; they are NOT safety glasses.** Following this rule will reduce the risk of serious personal injury.
- **Protect your lungs. Wear a face or dust mask if the operation is dusty.** Following this rule will reduce the risk of serious personal injury.
- **Protect your hearing. Wear hearing protection during extended periods of operation.** Following this rule will reduce the risk of serious personal injury.
- **Inspect power tool cords periodically and, if damaged, have repaired at your nearest Authorized Service Center. Constantly stay aware of cord location.** Following this rule will reduce the risk of electric shock or fire.
- **Check damaged parts. Before further use of the power tool, a guard or other part that is damaged should be carefully checked to determine that it will operate properly and perform its intended function. Check for alignment of moving parts, binding of moving parts, breakage of parts, mounting, and any other conditions that may affect its operation. A guard or other part that is damaged should be properly repaired or replaced by an Authorized Service Center.** Following this rule will reduce the risk of shock, fire, or serious injury.
- **Make sure your extension cord is in good condition. When using an extension cord, be sure to use one heavy enough to carry the current your product will draw. A wire gauge size (A.W.G.) of at least 14 is recommended for an extension cord 50 feet or less in length. A cord exceeding 100 feet is not recommended. If in doubt, use the next heavier gauge. The smaller the gauge number, the heavier the cord. An undersized cord will cause a drop in line voltage resulting in loss of power and overheating.**
- **Inspect for and remove all nails from lumber before using this power tool.** Following this rule will reduce the risk of serious personal injury.
- **Save these instructions.** Refer to them frequently and use them to instruct others who may use this power tool. If you loan someone this power tool, loan them these instructions also.



## WARNING:

Some dust created by power sanding, sawing, grinding, drilling, and other construction activities contains chemicals known to cause cancer, birth defects or other reproductive harm. Some examples of these chemicals are:











- lead from lead-based paints,
- crystalline silica from bricks and cement and other masonry products, and
- arsenic and chromium from chemically-treated lumber.

Your risk from these exposures varies, depending on how often you do this type of work. To reduce your exposure to these chemicals: work in a well ventilated area, and work with approved safety equipment, such as those dust masks that are specially designed to filter out microscopic particles.

---



# SYMBOLS

Some of the following symbols may be used on this tool. Please study them and learn their meaning. Proper interpretation of these symbols will allow you to operate the tool better and safer.

SYMBOL	NAME	DESIGNATION/EXPLANATION
V	Volts	Voltage
A	Amperes	Current
Hz	Hertz	Frequency (cycles per second)
W	Watt	Power
min	Minutes	Time
~	Alternating Current	Type of current
≡	Direct Current	Type or a characteristic of current
$n_0$	No Load Speed	Rotational speed, at no load
	Class II Construction	Double-insulated construction
.../min	Per Minute	Revolutions, strokes, surface speed, orbits etc., per minute
	Wet Conditions Alert	Do not expose to rain or use in damp locations.
	Read The Operator's Manual	To reduce the risk of injury, user must read and understand operator's manual before using this product.
	Eye Protection	Always wear safety goggles, safety glasses with side shields, or a full face shield when operating this product.
	Safety Alert	Precautions that involve your safety.
	No Hands Symbol	Failure to keep your hands away from the blade will result in serious personal injury.
	No Hands Symbol	Failure to keep your hands away from the blade will result in serious personal injury.
	No Hands Symbol	Failure to keep your hands away from the blade will result in serious personal injury.
	No Hands Symbol	Failure to keep your hands away from the blade will result in serious personal injury.
	Hot Surface	To reduce the risk of injury or damage, avoid contact with any hot surface.

# SYMBOLS

The following signal words and meanings are intended to explain the levels of risk associated with this product.

SYMBOL	SIGNAL	MEANING
	<b>DANGER:</b>	Indicates an imminently hazardous situation, which, if not avoided, will result in death or serious injury.
	<b>WARNING:</b>	Indicates a potentially hazardous situation, which, if not avoided, could result in death or serious injury.
	<b>CAUTION:</b>	Indicates a potentially hazardous situation, which, if not avoided, may result in minor or moderate injury.
	<b>CAUTION:</b>	(Without Safety Alert Symbol) Indicates a situation that may result in property damage.

## SERVICE

Servicing requires extreme care and knowledge and should be performed only by a qualified service technician. For service we suggest you return the product to your nearest **AUTHORIZED SERVICE CENTER** for repair. When servicing, use only identical replacement parts.



## WARNING:

To avoid serious personal injury, do not attempt to use this product until you read thoroughly and understand completely the operator's manual. Save this operator's manual and review frequently for continuing safe operation and instructing others who may use this product.

## WARNING:



The operation of any power tool can result in foreign objects being thrown into your eyes, which can result in severe eye damage. Before beginning power tool operation, always wear safety goggles, safety glasses with side shields, or a full face shield when needed. We recommend Wide Vision Safety Mask for use over eyeglasses or standard safety glasses with side shields. Always use eye protection which is marked to comply with ANSI Z87.1.

## SAVE THESE INSTRUCTIONS

# ELECTRICAL

## DOUBLE INSULATION

Double insulation is a concept in safety in electric power tools, which eliminates the need for the usual three-wire grounded power cord. All exposed metal parts are isolated from the internal metal motor components with protecting insulation. Double insulated tools do not need to be grounded.

### **WARNING:**

The double insulated system is intended to protect the user from shock resulting from a break in the tool's internal wiring. Observe all normal safety precautions to avoid electrical shock.

**NOTE:** Servicing of a tool with double insulation requires extreme care and knowledge of the system and should be performed only by a qualified service technician. For service, we suggest you return the tool to your nearest authorized service center for repair. Always use original factory replacement parts when servicing.

## ELECTRICAL CONNECTION

This tool has a precision-built electric motor. It should be connected to a **power supply that is 120 volts, 60 Hz, AC only (normal household current)**. Do not operate this tool on direct current (DC). A substantial voltage drop will cause a loss of power and the motor will overheat. If your tool does not operate when plugged into an outlet, double-check the power supply.

## EXTENSION CORDS

When using a power tool at a considerable distance from a power source, be sure to use an extension cord that has the capacity to handle the current the tool will draw. An undersized cord will cause a drop in line voltage, resulting in overheating and loss of power. Use the chart to determine the minimum wire size required in an extension cord. Only round jacketed cords listed by Underwriter's Laboratories (UL) should be used.

When working outdoors with a tool, use an extension cord that is designed for outside use. This type of cord is designated with "WA" on the cord's jacket.

Before using any extension cord, inspect it for loose or exposed wires and cut or worn insulation.

\*\*Ampere rating (on tool data plate)

Cord Length	Wire Size (A.W.G.)					
	0-2.0	2.1-3.4	3.5-5.0	5.1-7.0	7.1-12.0	12.1-16.0
25'	16	16	16	16	14	14
50'	16	16	16	14	14	12
100'	16	16	14	12	10	—

\*\*Used on 12 gauge - 20 amp circuit.

**NOTE:** AWG = American Wire Gauge

### **WARNING:**

Keep the extension cord clear of the working area. Position the cord so that it will not get caught on lumber, tools or other obstructions while you are working with a power tool. Failure to do so can result in serious personal injury.

### **WARNING:**

Check extension cords before each use. If damaged replace immediately. Never use tool with a damaged cord since touching the damaged area could cause electrical shock resulting in serious injury.

# FEATURES

## PRODUCT SPECIFICATIONS

Belt Size .....3 in. x 21 in.  
Sanding Surface..... 17.5 sq. in.  
No Load Speed .....800 - 1,500/min.

Input .....120 V, 60 Hz, AC only, 10.0 Amps  
Net Weight..... 10.5 lbs.

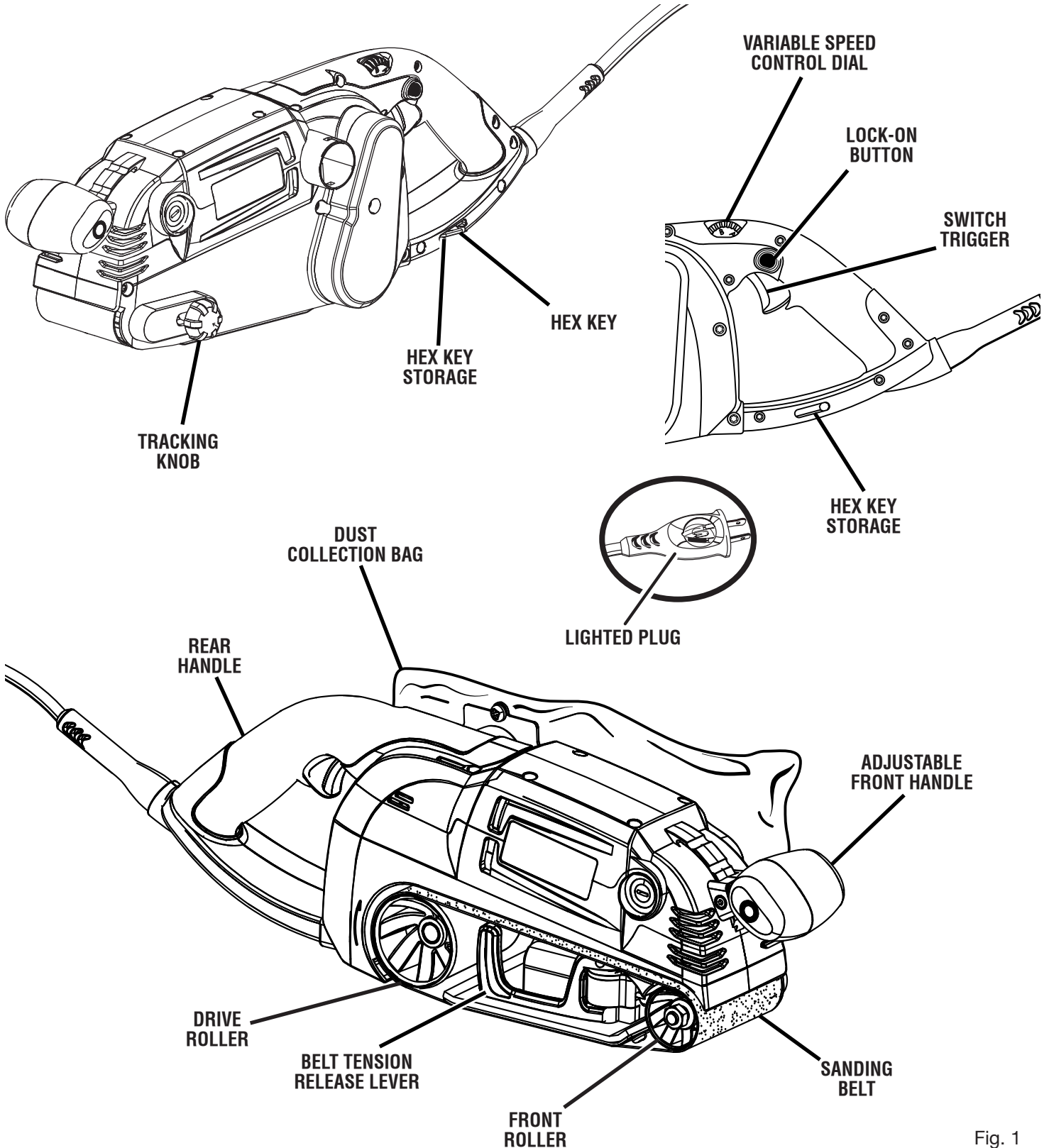

Fig. 1



# FEATURES

---

## KNOW YOUR BELT SANDER

See Figure 1.

Before attempting to use this product, familiarize yourself with all operating features and safety rules.

### SWITCH TRIGGER

To turn the sander **ON**, depress the switch trigger. Release switch trigger to turn your sander **OFF**.

### LOCK-ON BUTTON

The lock-on feature allows you to lock the switch trigger in the **ON** position. Locking the switch trigger on allows you to operate the sander for extended periods of time.

### TRACKING KNOB

The tracking knob allows you to easily adjust the belt tracking.

### VARIABLE SPEED CONTROL DIAL

The variable speed control feature allows the sander to develop a no load speed that can be adjusted from 800 to 1,500 feet/min. by rotating the dial from **A (slowest)** to **F (fastest)**.

# ASSEMBLY

---

## UNPACKING

This product requires assembly.

- Carefully remove the tool and any accessories from the box. Make sure that all items listed in the packing list are included.
- Inspect the tool carefully to make sure no breakage or damage occurred during shipping.
- Do not discard the packing material until you have carefully inspected and satisfactorily operated the tool.
- If any parts are damaged or missing, please call 1-866-539-1710 for assistance.

## PACKING LIST

Variable Speed Belt Sander

Handle Assembly (Screw, Hex Wrench, Handle)

Dust Collection Bag

Sanding Belt

Operator's Manual

## DUST COLLECTION BAG

The dust collection bag attaches to the sander and keeps dust to a minimum.

## BELT TENSION RELEASE LEVER

The tension release lever aids in quick and easy belt changes.

## ADJUSTABLE FRONT HANDLE

This feature allows user to adjust the front handle using a supplied hex key for ease of operation.

## POWER CORD

The 12-foot cord has a built-in cord wrap.

## LIGHTED PLUG

The lighted plug helps to easily identify live tools.

## ERGONOMIC DESIGN

The design provides for easy handling. It is designed for comfort and ease of operation in different positions and at different angles.

---

### **WARNING:**

If any parts are missing do not operate this tool until the missing parts are replaced. Failure to do so could result in possible serious personal injury.

---

---

### **WARNING:**

Do not attempt to modify this tool or create accessories not recommended for use with this tool. Any such alteration or modification is misuse and could result in a hazardous condition leading to possible serious personal injury.

---

---

### **WARNING:**

Do not connect to power supply until assembly is complete. Failure to comply could result in accidental starting and possible serious personal injury.

---

# OPERATION

## WARNING:

Do not allow familiarity with tools to make you careless. Remember that a careless fraction of a second is sufficient to inflict serious injury.

## WARNING:

Always wear safety goggles or safety glasses with side shields when operating power tools. Failure to do so could result in objects being thrown into your eyes resulting in possible serious injury.

## WARNING:

Do not use any attachments or accessories not recommended by the manufacturer of this tool. The use of attachments or accessories not recommended can result in serious personal injury.

## WARNING:

Before connecting the sander to a power supply, make sure it is not in the locked-on position. Failure to do so could result in accidental starting of the tool resulting in serious injury.

## APPLICATIONS

You may use this tool for the purposes listed below:

- Sanding wood, metals, plastics, and other materials
- Smoothing rough boards, chamfering, rounding edges
- Removing rust, paint, varnishes, and stains

## WARNING:

If your sanding job becomes particularly dusty or if you have a breathing condition, wear a dust mask or respirator to prevent damage to your health.

## SELECTING SANDING BELTS

Selecting the correct size and type of sanding belt is an important step in achieving a high quality sanded finish. Aluminum oxide, silicon carbide, and other synthetic abrasives are best for power sanding.

In general, when sanding, coarse grit removes the most material and fine grit produces the best finish. The condition of the surface to be sanded determines which grit will do the best job. If the surface is rough, start with a coarse grit and sand until the surface is uniform. Then use medium grit to remove scratches left by the coarser grit. Finally, use finer grit for finishing the surface. Always continue sanding with each grit until the surface is uniform.

## SETTING THE BELT SANDER SPEED

Refer to the chart below for belt sander speed selections.

MATERIAL	SPEED						BELT GRIT					
	A	B	C	D	E	F	40	60	80	100	150	240
UNDRESSED LUMBER					★	★	●	●				
SOFTWOOD		★								●	●	
CHIPBOARD				★	★			●	●			
LUMBER	★	★										●
RUST REMOVAL			★	★			●	●				
PAINTED SURFACE					★	★	●	●				
NON FERROUS METAL			★						●	●		

# OPERATION

## VARIABLE SPEED

See Figure 2.

The sander has a variable speed control dial, **A (slowest)** to **F (fastest)**, designed to allow operator control of belt speed. To increase belt speed, turn the variable speed control dial to a higher setting. Turn to a lower setting to decrease belt speed. Refer to the chart on page 10 for proper speed selections.

## PROPER HAND PLACEMENT

See Figure 3.

For ease of operation the sander has an adjustable front handle and a stationary rear handle. These handles allow two-handed operation which aids in maintaining control, keeping sander level with workpiece, and keeping hands clear of sanding belt. When operating the sander always hold the front handle with the left hand and the rear handle with the right hand as shown.

### **⚠ WARNING:**

Keep hands and fingers clear of moving sanding belt, front pulley, and drive roller assembly. Failure to do so will result in the sanding of the hands or fingers possibly causing serious injury.

### **⚠ WARNING:**

Do not let your fingers rest over the front or right edge of the sander. If the sanding belt were to run off, or if it were not properly adjusted, your fingers could come in contact with the moving sanding belt resulting in possible serious injury.

## TURNING ON/OFF THE SANDER

See Figure 4.

- To turn on the sander: Depress the switch trigger.
- To turn off the sander: Release the switch trigger.

## SOFT START FEATURE

Soft start is a feature whereby the motor gradually ramps up to the selected top speed. For example, when a speed is selected with the speed limiting dial and the sander is stopped and then activated again, the sander will gradually ramp up to the previous speed setting once the switch trigger is pressed again.

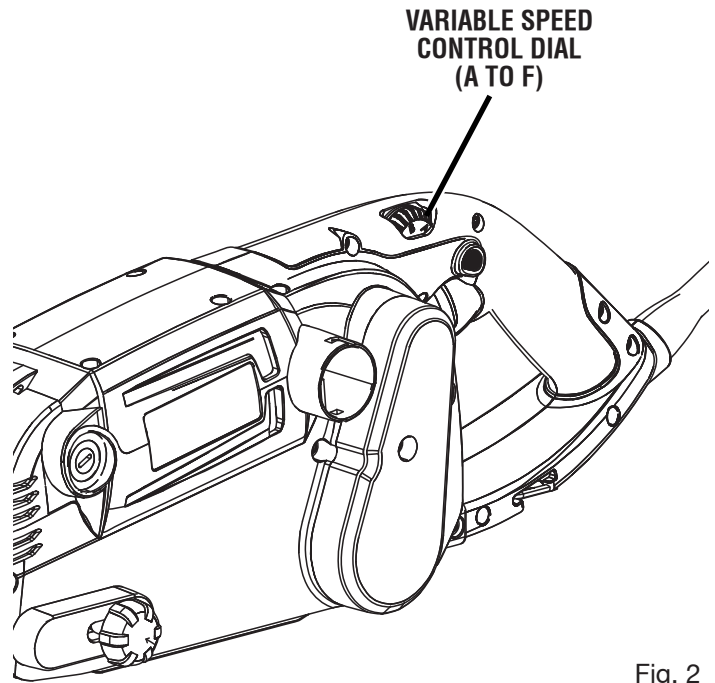

Fig. 2

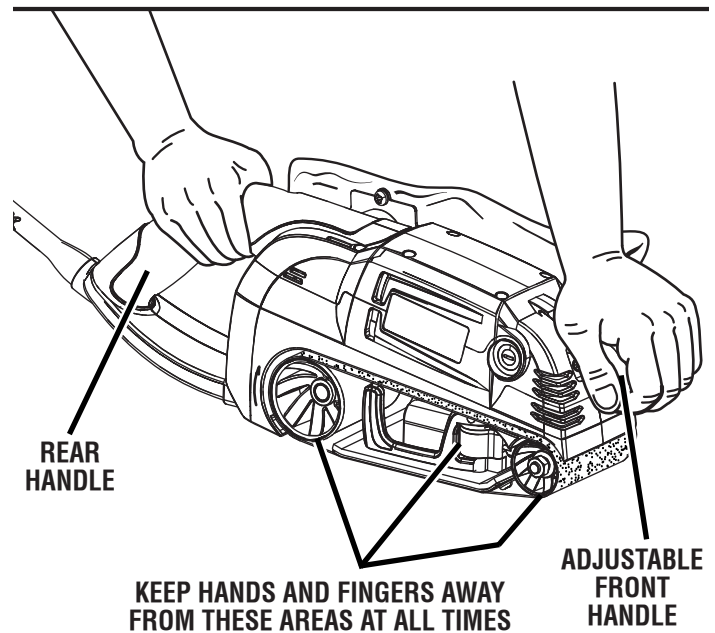

Fig. 3

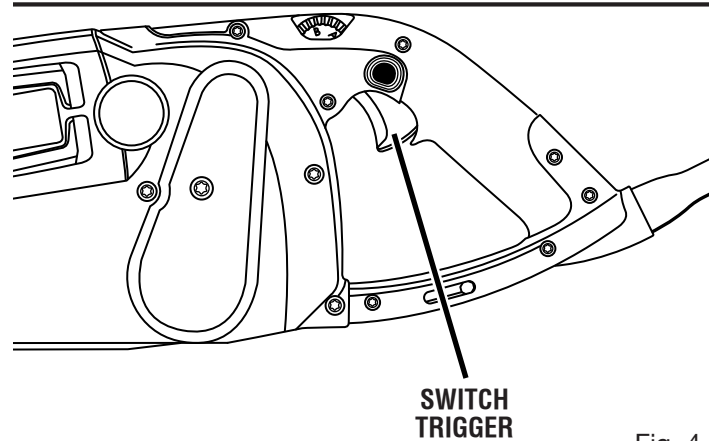

Fig. 4

# OPERATION

## TO INSTALL/CHANGE SANDING BELT

See Figures 5 - 6.

- Unplug the sander.
- Position sander as shown.

### **WARNING:**

Keep hands and fingers clear of front roller and spring mechanism at all times. Failure to do so could result in fingers getting pinched, causing possible serious injury.

Belt tension must be released in order to install and remove sanding belt:

- Release belt tension by lifting tension release lever.
- Install sanding belt; make sure arrow inside of belt is pointing in the direction of rotation, which is clockwise when looking into open side of sander.

**NOTE:** Match the arrow on the sanding belt to that of the housing.

### **CAUTION:**

If the sanding belt is not a bidirectional belt, ensure that the arrow inside the belt is pointing in the direction of the rotation (clockwise when looking into the open side of the sander). Installing unidirectional sanding belts backwards can create a hazardous condition.

- Align the sanding belt to its correct position.
- Lower tension release lever to secure the sanding belt.

## TO ADJUST FRONT HANDLE

See Figure 7.

- Unplug the belt sander.
- Remove the supplied hex key from hex key storage.
- Using hex key, remove hex bolt located on front handle.
- Move front handle to desired position aligning notch in handle mount on tool with hex bolt hole in handle, insert hex bolt and retighten front handle using hex key.
- Return hex key to hex key storage area located on the rear handle bridge.

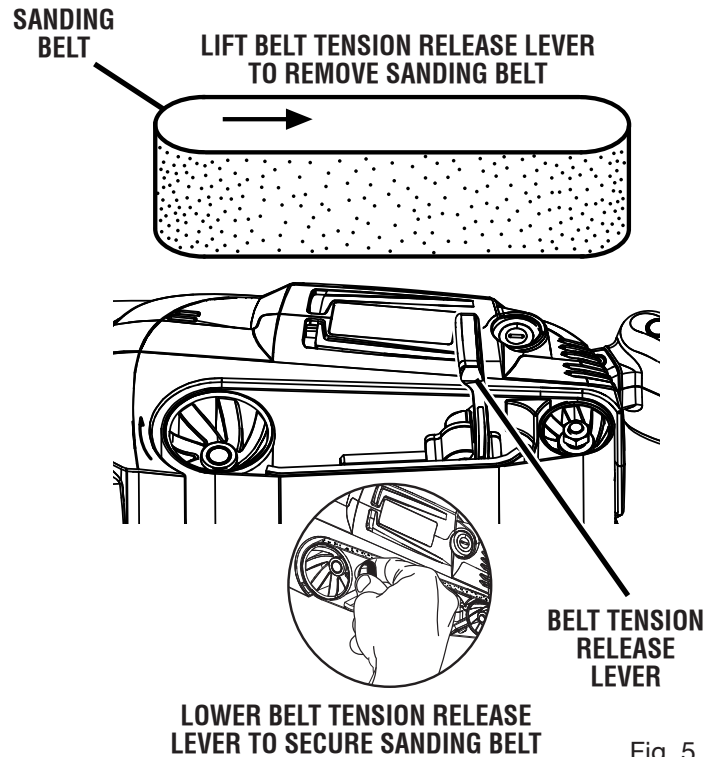
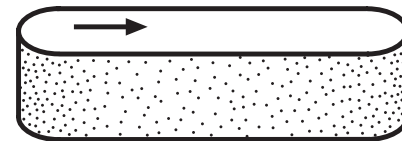

Fig. 5

### SANDING BELTS WITH DIRECTION OF ROTATION ARROWS MUST BE INSTALLED CORRECTLY



### SANDING BELTS WITHOUT DIRECTION OF ROTATION ARROWS CAN BE USED IN EITHER DIRECTION

Fig. 6

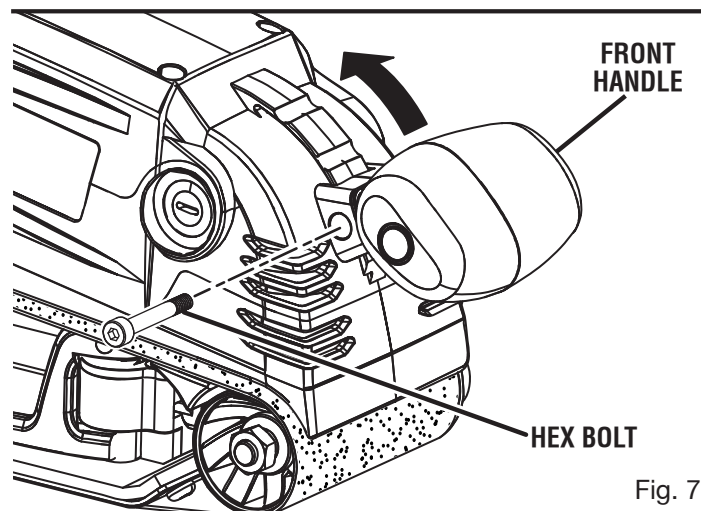

Fig. 7

# OPERATION

## LOCKING ON THE SANDER

See Figure 8.

The lock-on feature allows you to lock the switch trigger in the **ON** position. Locking the switch trigger on allows you to operate the sander for extended periods of time.

If you have the lock-on feature engaged during use and the sander is accidentally disconnected from the power supply, disengage the lock-on feature immediately. Also, do not lock the switch trigger if you might need to suddenly stop the sander.

### To lock-on the sander:

- Depress the switch trigger.
- Push in the lock-on button.
- Release the switch trigger.
- Release the lock-on button.

**NOTE:** To release the lock, depress and release the switch trigger.

## OPERATING THE SANDER

See Figure 9.

Clamp or otherwise secure the work to prevent it from moving under the sander.

### **WARNING:**

Unsecured work could be thrown back toward operator causing injury.

Before placing sander on work surface, squeeze the switch trigger and let the motor reach its maximum speed, then lower the sander to the work surface with a slight forward motion. Using the rear handle to control the sander and the front handle only to guide it, move it slowly over the work. Allowing the sander to remain in one place will result in an uneven surface.

### **WARNING:**

Keep a firm grip on sander with both hands at all times. Failure to do so could result in loss of control leading to possible serious injury.

The sander was designed to provide the proper weight on the sanding belt.

### Excessive pressure will result in the following:

- Uneven work.
- Clogged sanding belts.
- Premature sanding belt wear. Removal rate will **not** increase.
- Motor damage.
- Irregular sanding belt tracking.

**NOTE:** If the sanding belt moves while sanding, you may be applying too much pressure. When this occurs, remove sander from workpiece. If belt tracking is properly adjusted, sanding belt will return to its normal and correct position on the drive roller and front roller.

Use a coarser belt when heavy sanding is desired, not heavy pressure. The importance of this cannot be over-emphasized. Weight has been built into the tool to give the most efficient pressure at the proper location.

**NOTE:** The front roller of the sander was not designed for contour sanding. Sanding on the front roller could cause irregularity in sanding belt tracking and will damage the front roller.

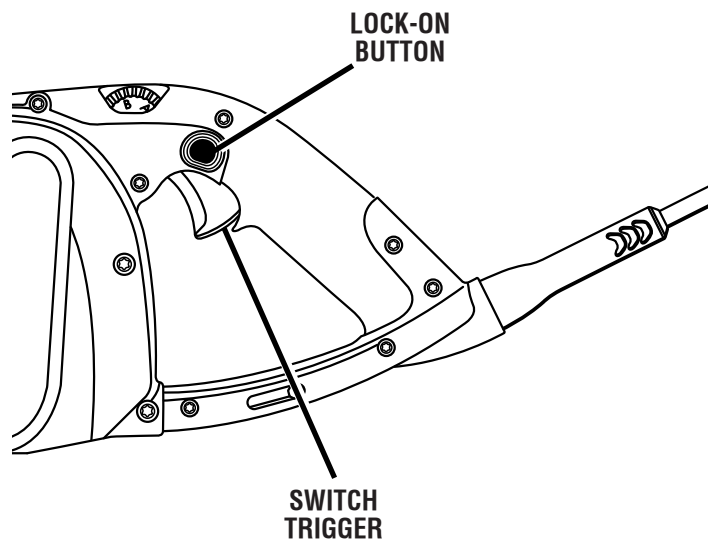

Fig. 8

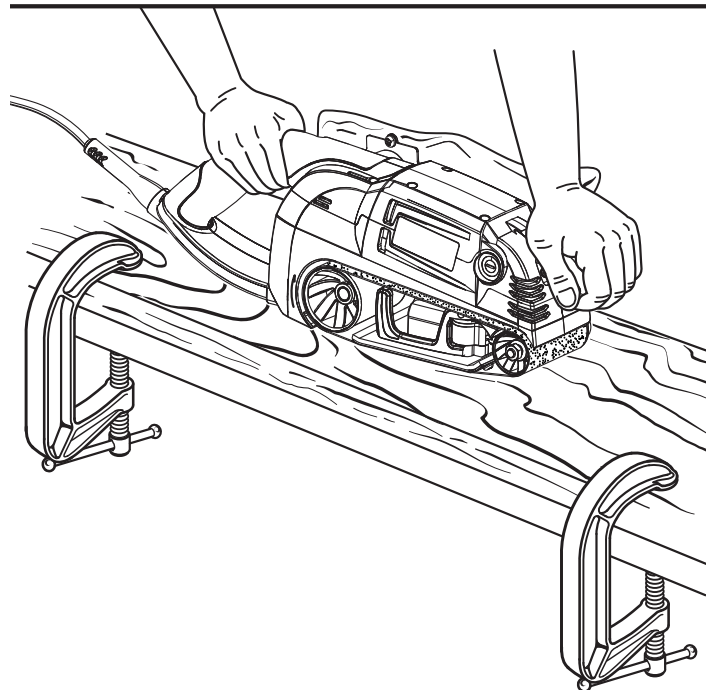

Fig. 9

# OPERATION

## TO ADJUST SANDING BELT TRACKING

See Figure 10.

- Connect the sander to power supply.
- With sander positioned as shown below, pull switch trigger and release immediately.

**NOTE:** This position is for adjustments only. Sanding belt should not be in contact with workpiece or any foreign objects when making belt tracking adjustments.

- Observe tracking of sanding belt. If the sanding belt runs inward, slowly turn the tracking knob clockwise. If the sanding belt runs outward, slowly turn the tracking knob counterclockwise. This should be done until you are sure belt will not run off sander, or come in contact with internal parts.

**NOTE:** After installing a new sanding belt, it may become necessary to change the adjustment several times until the belt becomes conditioned.

- When you are sure the belt will not rub against internal parts, start the sander and fine adjust the tracking knob until the belt stabilizes.

When correctly adjusted, the outer edge of the belt will be even with the outer edge of the sander. Belt life will be greatly increased if a few seconds are spent adjusting the belt tracking.

**NOTE:** Replace a torn sanding belt immediately.

### **⚠ WARNING:**

Keep hands and fingers away from moving sanding belt. Any part of body coming in contact with moving sanding belt could result in serious injury. Do not wear loose clothing or jewelry when operating sander. They could get caught in moving parts and foreign objects could get thrown from sander causing injury.

### **CAUTION:**

If the sanding belt wears excessively on the inner edge it is probably adjusted too far inward and is rubbing against internal parts. If this is the case, readjust the tracking knob.

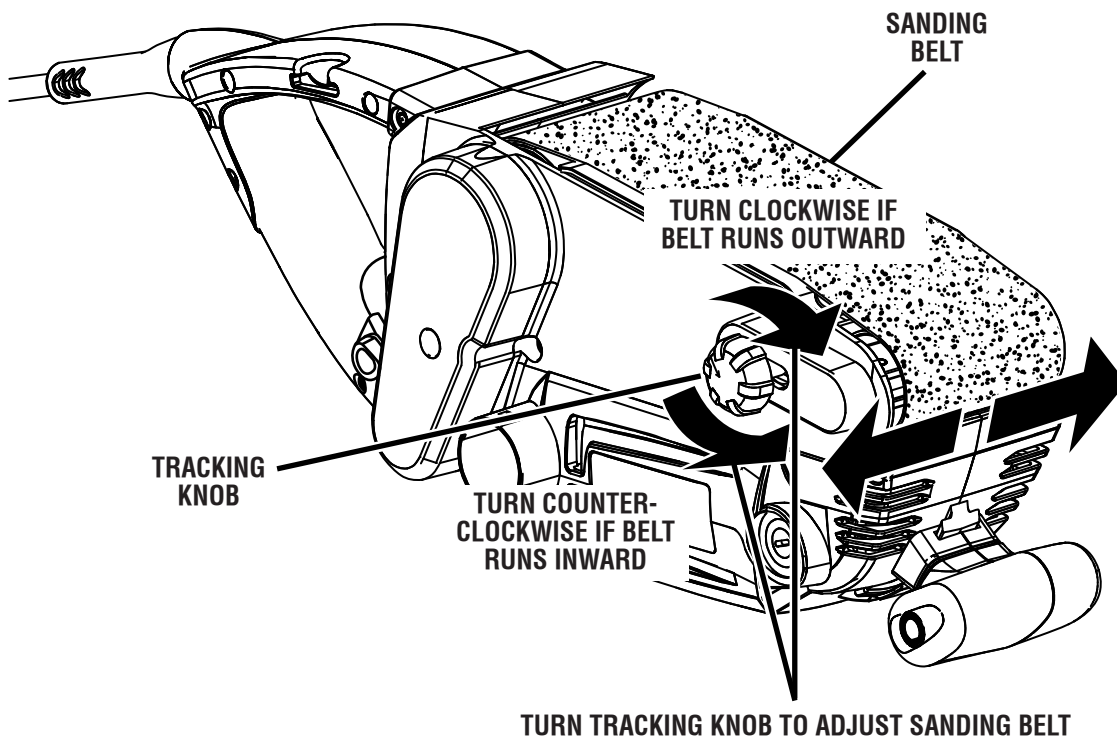

Fig. 10

# OPERATION

## **⚠ WARNING:**

To prevent the possibility of sawdust or foreign objects being thrown into your face and eyes, never attempt to use the sander without dust bag properly installed. Sawdust or foreign objects being thrown into your face and eyes could result in possible serious injury.

## **DUST BAG**

See Figure 11.

The dust bag provides a dust collection system for the sander. It should be installed over the exhaust hole located on the side of the sander. For more efficient operation, empty dust bag when half full.

**Do not** connect sander to power supply before installing dust bag.

## **To install/remove dust bag:**

- Unplug the sander.
- Place the opening of dust bag over exhaust hole of the sander, aligning the notch inside opening of dust bag with groove on exhaust hole. The bag should be installed with the zipper down when sander is in upright position.
- Turn the dust bag counterclockwise to secure in place.
- To remove the dust bag, turn clockwise and pull off.

## **To empty dust bag:**

Remove dust bag from sander, open zipper, and shake out dust.

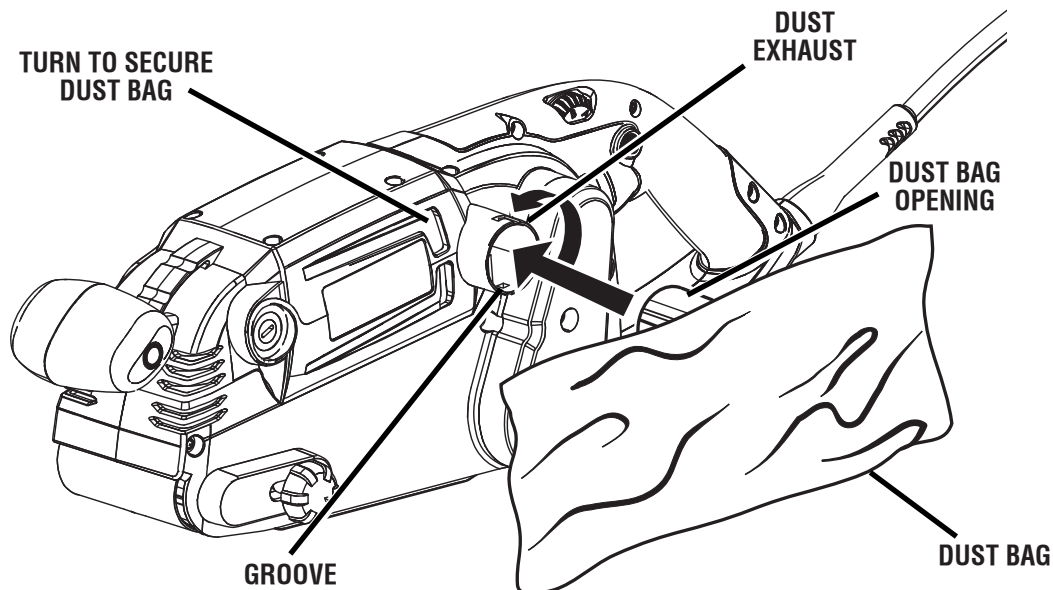

Fig. 11

## **⚠ WARNING:**

Do not use the dust collection bag when sanding metal. Using the dust collection bag when sanding metal creates a fire hazard, which could damage the tool and lead to serious personal injury.

## **⚠ WARNING:**

Collected sanding dust from sanding surface coatings such as polyurethanes, linseed oil, etc., can self-ignite in the sander dust collection bag or elsewhere and cause fire. To reduce the risk of fire, always empty the dust bag frequently while sanding and never store or leave a sander without totally emptying its dust bag. Also follow the recommendations of the coatings manufacturers.

# MAINTENANCE

## **WARNING:**

When servicing use only identical RIDGID replacement parts. Use of any other parts may create a hazard or cause product damage.

## **WARNING:**

Always wear safety goggles or safety glasses with side shields during power tool operation or when blowing dust. If operation is dusty, also wear a dust mask.

## GENERAL MAINTENANCE

Avoid using solvents when cleaning plastic parts. Most plastics are susceptible to damage from various types of commercial solvents and may be damaged by their use. Use clean cloths to remove dirt, dust, oil, grease, etc.

## **WARNING:**

Do not at any time let brake fluids, gasoline, petroleum-based products, penetrating oils, etc., come in contact with plastic parts. Chemicals can damage, weaken or destroy plastic which may result in serious personal injury.

Electric tools used on fiberglass material, wallboard, spackling compounds, or plaster are subject to accelerated wear and possible premature failure because the fiberglass chips and grindings are highly abrasive to bearings, brushes, commutators, etc. Consequently, we do not recommend using this tool for extended work on these types of materials. However, if you do work with any of these materials, it is extremely important to clean the tool using compressed air.

## LUBRICATION

All of the bearings in this tool are lubricated with a sufficient amount of high grade lubricant for the life of the unit under normal operating conditions. Therefore, no further lubrication is required.

## BRUSH REPLACEMENT

See Figure 12.

**NOTE:** This belt sander is equipped with externally accessible brushes.

- Unplug the sander.

## **WARNING:**

Failure to unplug the tool could result in accidental starting causing possible serious injury.

**NOTE:** There are 2 brush caps located on either side of front housing below the front handle.

- Remove brush caps (2) using a screwdriver.
- Remove brush assemblies (2).
- Check for wear. Replace both brush assemblies when either has less than 1/4 in. length of carbon remaining.  
**NOTE:** Do not replace one side without replacing the other.
- Reassemble using new brush assemblies. Make sure curvature of brush matches curvature of motor and that brush moves freely in brush tube.
- Reassemble by reversing the steps listed above.
- Tighten all brush caps securely. **Do not** over tighten.

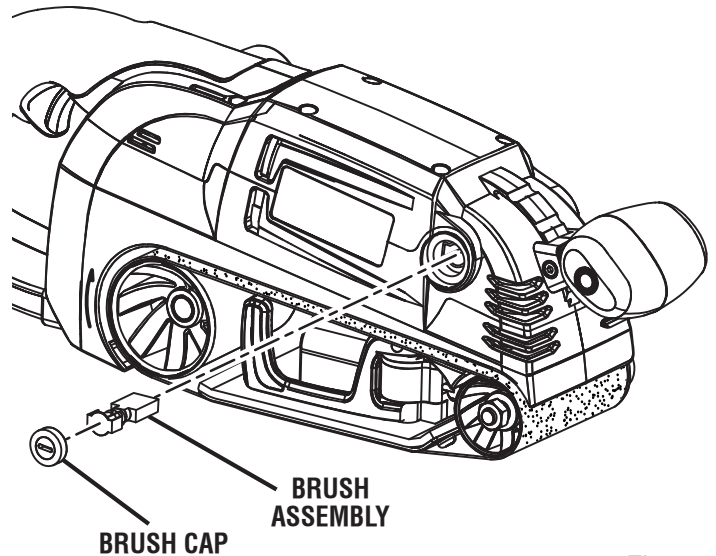

Fig. 12



# MAINTENANCE

## TIMING BELT REPLACEMENT

See Figures 13 - 14.

- Unplug the sander.
- Remove dust bag.
- Lay belt sander on side as shown.
- Remove sanding belt from sander. Follow instructions on page 12 to remove sanding belt.

**NOTE:** Removing sanding belt will simplify the process of installing a new timing belt.

- Remove belt cover screw and belt cover.
- Force old timing belt from large pulley with a screwdriver and remove it from small pulley. If it is worn out, simply cut the old timing belt and remove.
- Install new timing belt over small pulley first.
- Holding the timing belt as shown in Figure 14, press belt onto the large pulley turning it as you press the belt on.
- Reassemble belt cover and screw.
- Tighten screw securely.
- Install the sanding belt.

### **WARNING:**

Never attempt to operate the belt sander without belt cover in place.

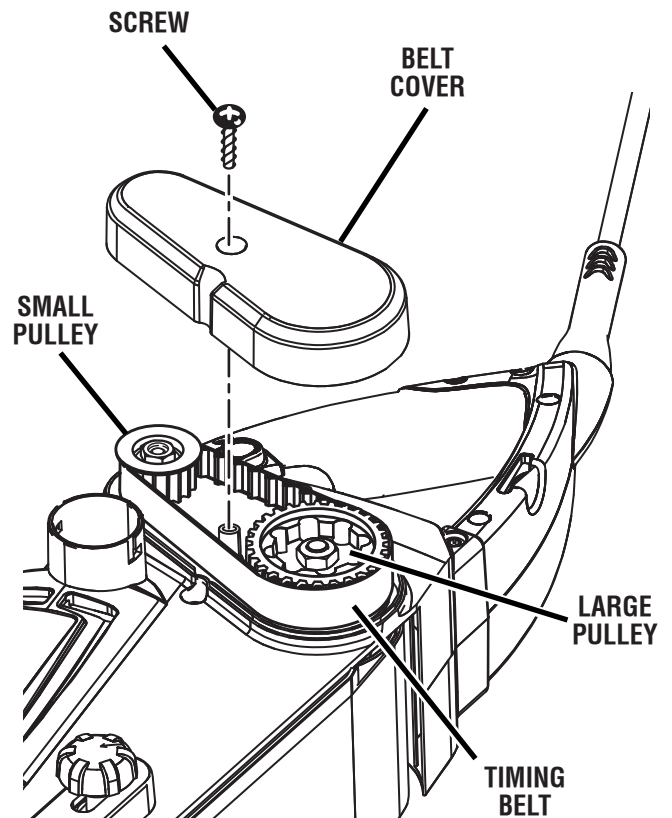

SANDER SHOWN WITH DUST BAG AND SANDING BELT REMOVED

Fig. 13

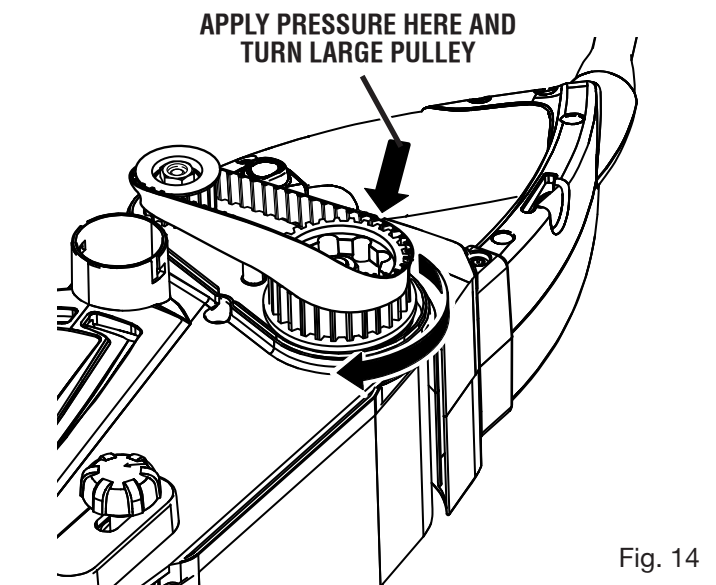

Fig. 14



# WARRANTY

---

## RIDGID® HAND HELD AND STATIONARY POWER TOOL 3 YEAR LIMITED SERVICE WARRANTY

Proof of purchase must be presented when requesting warranty service.

Limited to RIDGID® hand held and stationary power tools purchased 2/1/04 and after. This product is manufactured by One World Technologies, Inc. The trademark is licensed from RIDGID, Inc. All warranty communications should be directed to One World Technologies, Inc., attn: RIDGID Hand Held and Stationary Power Tool Technical Service at (toll free) 1-866-539-1710.

### 90-DAY SATISFACTION GUARANTEE POLICY

During the first 90 days after the date of purchase, if you are dissatisfied with the performance of this RIDGID® Hand Held and Stationary Power Tool for any reason you may return the tool to the dealer from which it was purchased for a full refund or exchange. To receive a replacement tool you must present proof of purchase and return all original equipment packaged with the original product. The replacement tool will be covered by the limited warranty for the balance of the 3 YEAR service warranty period.

### WHAT IS COVERED UNDER THE 3 YEAR LIMITED SERVICE WARRANTY

This warranty on RIDGID® Hand Held and Stationary Power Tools covers all defects in workmanship or materials and normal wear items such as brushes, chucks, motors, switches, cords, gears and even cordless batteries in this RIDGID® tool for three years following the purchase date of the tool. Warranties for other RIDGID® products may vary.

### HOW TO OBTAIN SERVICE

To obtain service for this RIDGID® tool you must return it; freight prepaid, or take it in to an authorized service center for RIDGID® branded hand held and stationary power tools. You may obtain the location of the authorized service center nearest you by calling (toll free) 1-866-539-1710 or by logging on to the RIDGID® website at [www.ridgid.com](http://www.ridgid.com). When requesting warranty service, you must present the original dated sales receipt. The authorized service center will repair any faulty workmanship, and either repair or replace any part covered under the warranty, at our option, at no charge to you.

### WHAT IS NOT COVERED

This warranty applies only to the original purchaser at retail and may not be transferred. This warranty only covers defects arising under normal usage and does not cover any malfunction, failure or defect resulting from misuse, abuse, neglect, alteration, modification or repair by other than an authorized service center for RIDGID® branded hand held and stationary power tools. Consumable accessories provided with the tool such as, but not limited to, blades, bits and sand paper are not covered.

**RIDGID, INC. AND ONE WORLD TECHNOLOGIES, INC. MAKE NO WARRANTIES, REPRESENTATIONS OR PROMISES AS TO THE QUALITY OR PERFORMANCE OF ITS POWER TOOLS OTHER THAN THOSE SPECIFICALLY STATED IN THIS WARRANTY.**

### ADDITIONAL LIMITATIONS

To the extent permitted by applicable law, all implied warranties, including warranties of MERCHANTABILITY or FITNESS FOR A PARTICULAR PURPOSE, are disclaimed. Any implied warranties, including warranties of merchantability or fitness for a particular purpose, that cannot be disclaimed under state law are limited to three years from the date of purchase. One World Technologies, Inc. and RIDGID, Inc. are not responsible for direct, indirect, incidental or consequential damages. Some states do not allow limitations on how long an implied warranty lasts and/or do not allow the exclusion or limitation of incidental or consequential damages, so the above limitations may not apply to you. This warranty gives you specific legal rights, and you may also have other rights which vary from state to state.

---

**One World Technologies, Inc.**

Hwy. 8

Pickens, SC 29671

---

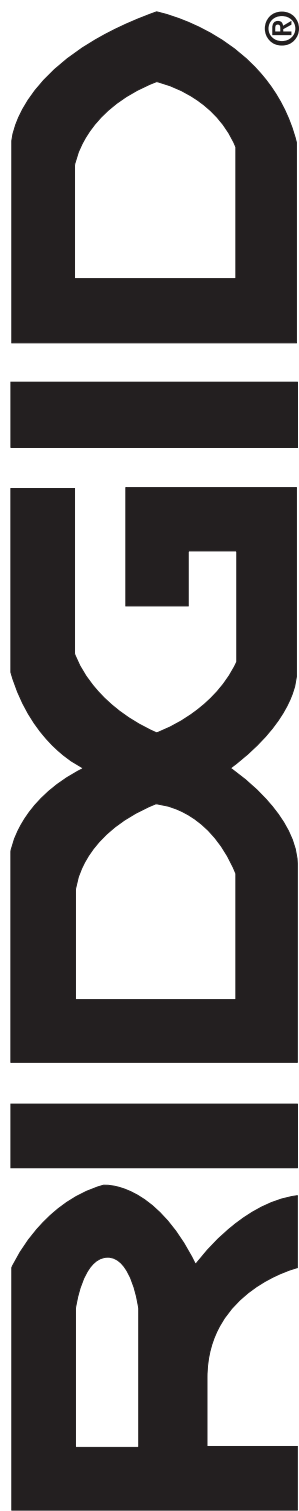

# OPERATOR'S MANUAL

## 3 in. x 21 in. BELT SANDER

### VARIABLE SPEED DOUBLE INSULATED

#### R2720

#### **Customer Service Information:**

For parts or service, contact your nearest RIDGID authorized service center. Be sure to provide all relevant information when you call or visit. For the location of the authorized service center nearest you, please call 1-866-539-1710 or visit us online at [www.ridgid.com](http://www.ridgid.com).

The model number of this tool is found on a plate attached to the motor housing. Please record the serial number in the space provided below. When ordering repair parts, always give the following information:

**Model No.** \_\_\_\_\_ R2720 \_\_\_\_\_

**Serial No.** \_\_\_\_\_