



REFRIGERATION
EVEREST
www.EVERESTref.com

Owner's Manual for models:

Direct Draw Keg Refrigerators	EBD1, EBD2, EBD3, EBD4
24" Deep Direct Draw Keg Refrigerators	EBDS2-24, EBD2-24, EBD3-24, EBD4-24
Back Bar & Direct Draw Keg Refrigerators	EBD2-BB, EBD2-BBG, EBD3-BB, EBD3-BBG
24" Deep Back Bar & Direct Draw Keg Refrigerators	EBDS2-BB-24, EBD2-BB-24, EBD3-BB-24 EBDS2-BBG-24, EBD2-BBG-24, EBD3-BBG-24
Club Top Direct Draw Keg Refrigerators	EBD2-CT, EBD3-CT, EBD4-CT

A Step Above the Standard



Thank you for selecting an EVEREST product



WARNING - When using your appliance, always follow basic precautions, including the following :

When installing the unit, be careful that the electrical cord is not under the unit or pressed against the wall. This could cause a damage to the cord.

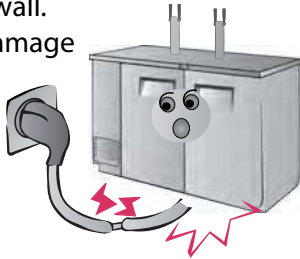

Before starting the unit for the first time, make sure the unit is free from all packaging. Packaging left on the unit during operation may cause a fire hazard.

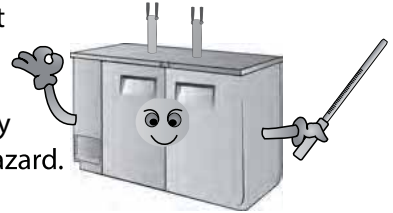

To prevent electrical shock, please do not plug or unplug the cord with wet hands.

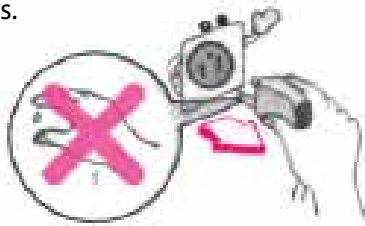

Before cleaning or maintaining the unit, please unplug it. Do not use any flammable cleaning products on or around the unit.

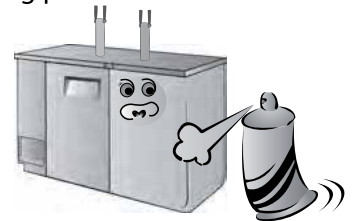

Install the unit on a hard and level surface.

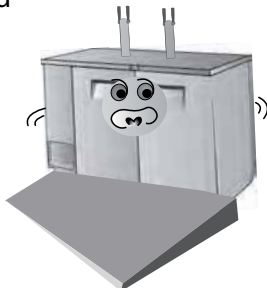

Please do not hang or climb on the unit as this may cause the unit to fall.



Please do not store temperature sensitive items in the unit, such as medical or science research related materials.



If you suspect a refrigerant leak, unplug the unit and immediately contact an authorized service technician.





WARNING - Read and follow all safety notices in this installation guide. These notices provide helpful safety and efficient operation information. Failure to do so may lead to serious injury and / or damage to the unit.

To minimize shock and fire hazards, be sure not to overload the outlet into which the unit is plugged into. A dedicated circuit of sufficient amperage is required.



To prevent damage to the electrical components, have the unit plugged in directly to its own circuit. EVEREST is not responsible for any damage caused by improper electrical connections resulting from electrical power failure, use of extension cords & surge protectors, and any voltage drops to the unit.

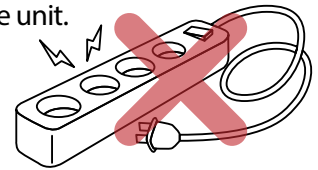

To prevent electrical shock and malfunction, do not spray the unit with water.

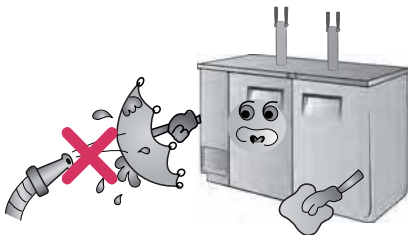

Clean the prongs of the electrical plug with a soft cloth or brush before plugging it into an electrical receptacle to prevent a fire hazard.



When it is time to salvage the unit, make sure to remove the rubber gaskets from the doors to prevent the risk of children or animals getting trapped inside the unit.

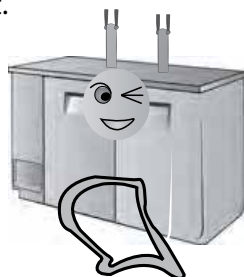

To prevent electrical shock and damage to the electrical cord, please hold the plug head when plugging and unplugging the unit.



Do not use the electrical cord or plug if they are damaged in any way.



To avoid personal injuries from broken glass, please do not place glass items in the freezer.



Avoid installing the unit where it could be exposed to water or moisture.

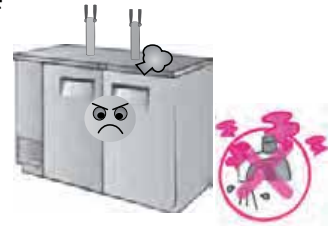

After unplugging the unit, please wait at least 6 minutes before re-plugging it in. Failure to do so could cause extensive damage to the compressor.

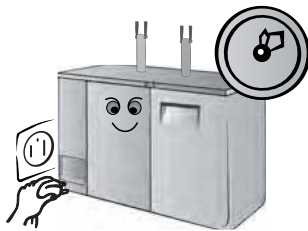

Please do not attempt to remove or repair any components unless you are an authorized service technician.

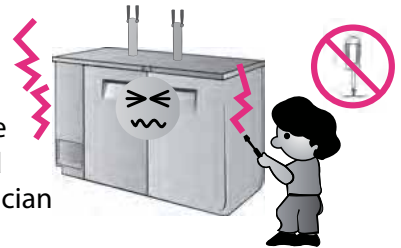

If the unit will not be used for an extended period of time, please unplug it from the outlet.

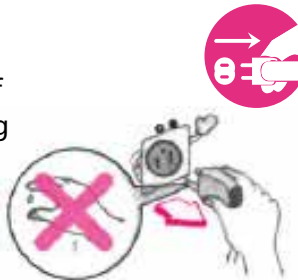

Do not put your hands under the unit when moving it. You could be injured by sharp edges, protruding parts, crushing, etc.

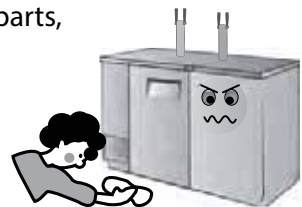

The refrigerator compartment temperature should be set at 32°F~41°F(See page 9). Setting the temperature out of the recommended ranges will void the unit's warranty.

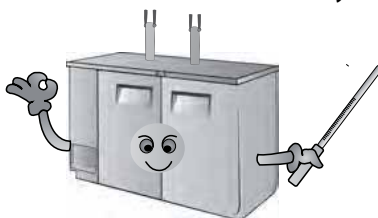

Install the unit on a hard and level surface or the unit could produce undesired noises.

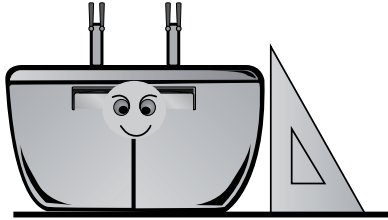

The unit should be at least 2" away from the wall.

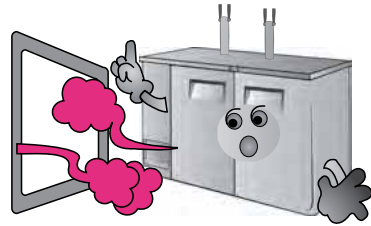

Indoor Use Only

Outdoor use may cause a decrease in performance and significant damage to the unit.

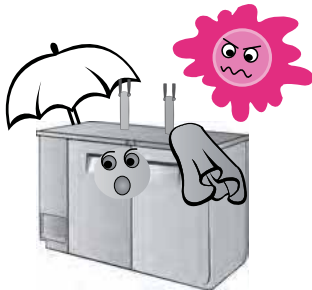

Dusty and High Humidity Areas

Dusty environments will cause the condenser coil to prematurely clog which will require it to be cleaned more often. High humidity environments could cause the unit to rust.

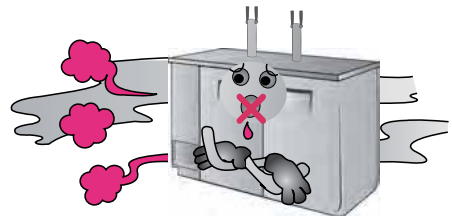

Do not build an enclosure or cabinet around the unit.

Restricting the airflow around the unit's condenser area will cause the compressor to work harder, which can result in compressor failure and the unit not being able to maintain the desired temperature.

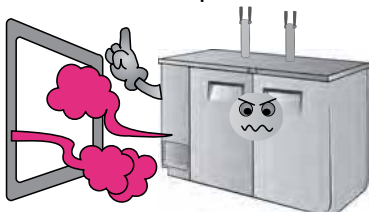

Select a location away from other heat and moisture generating equipment such as stoves, ovens, dish washers, etc.

High ambient temperatures cause the compressor to work harder, which can result in compressor failure and the unit not being able to maintain the desired temperature.

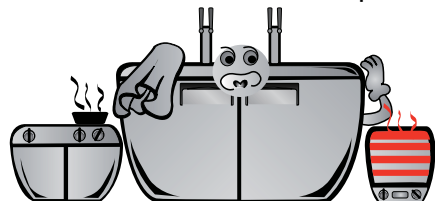

Shelf Cleaning

Periodically remove the shelves from the unit and clean them with mild soap and warm water.



Door Gasket Cleaning

To preserve the life span of the door gaskets, clean the gaskets with mild soap and water on a regular basis.

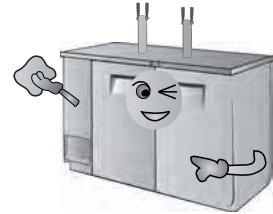

Do not use the following products when cleaning

Clean the exterior of the product with mild soap and warm water. Never use steel wool, strong acids, abrasive cleaners or degreasers. Acidic products and products containing vinegar must be stored in sealed containers to prevent corrosion to the interior of the unit and the evaporator coil. (corrosion resulting from the lack of or improper maintenance will not be covered under warranty).

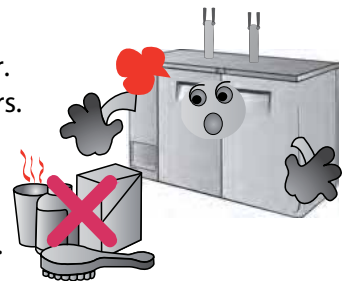

Interior Cleaning

Clean the interior surface of the unit with mild soap and warm water. Do not let water accumulate inside the unit. To prevent water damage, wipe the interior of the unit with a dry cloth as needed. Do not use abrasive cleaners, concentrated detergents, bleaches, cleaning waxes, solvents or polishes to clean the interior of the unit.

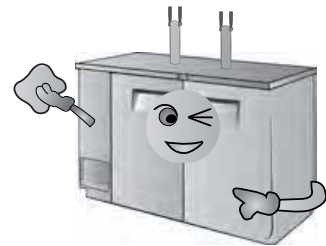





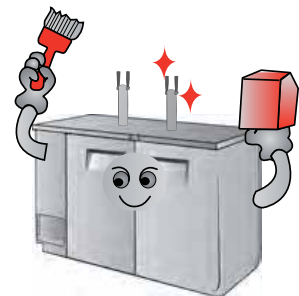



Condenser Coil Cleaning

Poor condensing unit performance is caused by heavy dust build-up on the condenser coil. The condenser coil should be cleaned monthly. Shine a flashlight through the condenser coil to check for dirt between the fins. Clean the outside of the condenser with a soft brush or a vacuum with a brush attachment. The condenser coil should be cleaned in the direction of the fins, top to bottom, not side to side. Be careful not to bend the fins.

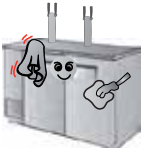

Please check the following before requesting service.

	Symptom	Possible Solutions
	Condensing unit fails to start	<ol style="list-style-type: none"> Ensure the electrical cord has been connected. Ensure the unit is turned on.
	Cabinet does not maintain proper temperature	<ol style="list-style-type: none"> Check the door gaskets for proper seal. Check to see if the temp. control setting is too high, then adjust as necessary. Avoid installing the unit next to heat generating equipment and direct sunlight. Avoid storing hot contents. Ensure the doors are fully closed.
	Refrigerated compartment is too cold	<ol style="list-style-type: none"> Adjust the temperature control to a warmer setting.
	Noisy operation	<ol style="list-style-type: none"> Check for loose parts. Check for tubing rattle. Check for a bent fan blade. Check for damaged fan motor bearings. Ensure the unit is stable. Ensure the cabinet is level.
	Condensation on the exterior surface	<ol style="list-style-type: none"> Condensation on the exterior surface of the unit is perfectly normal during periods of high humidity. Check door alignment and gaskets for proper seal.
	Sound of water dripping	<ol style="list-style-type: none"> This is the sound of the refrigerant circulating during the compressor rest period and it is normal.
	Exterior walls are warm	<ol style="list-style-type: none"> Heaters have been placed around the door openings to prevent condensation buildup. This is normal.
	Condensation on the interior	<ol style="list-style-type: none"> Condensation can occur during hot and humid weather with frequent or prolonged door opening. This is normal. The doors might not be closed properly. Check door alignment and for proper seal.

Shelves(If equipped)

The unit's shelves are adjustable so that the refrigerated compartment can be configured to suit your needs.

The shelf clip pilasters are spaced and labeled in 1" increments for your convenience.

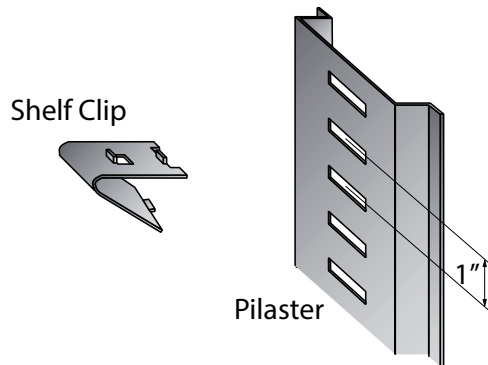

To install a shelf, hook the shelf clips into the pilasters by inserting the top part of the clips first and then the bottom. Each shelf requires 4 clips.

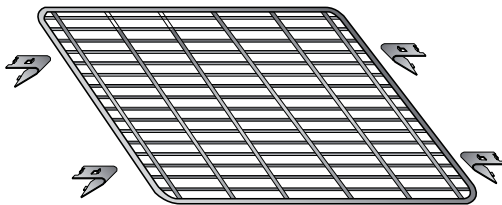

To remove a shelf, start by unloading the shelf. Second, remove the shelf itself. Finally, remove the shelf clips by tilting them up and allowing the bottom of the clip to come out first and then remove the top part of the clip from the pilaster.



Warning - Never attempt to adjust a shelf when loaded!



Direct Draw Keg Refrigerators

Model	EBD1	EBD2	EBD3	EBD4
Capacity(Cu. Ft.)	8.19	20.09	24.01	32.37
Door(s)	1	2	2	3
Shelves	-	-	-	-
Compressor (HP)	1/6	1/4	1/4	1/3
Power (V-Hz-Ph)	115-60-1	115 -60-1	115-60-1	115-60-1
Temp. Range (°F)	32 - 42	32 - 42	32 - 42	32 - 42
Refrigerant	R-134A	R-134A	R-134A	R-134A
Crated Weight (LBS)	160	275	313	363
Amps (A)	3.90	4.50	4.50	4.50
Exterior Dimensions (W x D x H* inches)	23 1/2 x 31 1/2 ^a x 39 ^b	57 3/4 x 27 x 37	68 x 27 x 37	89 1/4 x 27 x 37

24" Deep Direct Draw Keg Refrigerators

Model	EBDS2-24	EBD2-24	EBD3-24	EBD4-24
Capacity(Cu. Ft.)	13.95	16.86	20.41	27.76
Door(s)	2	2	2	3
Shelves	-	-	-	-
Compressor (HP)	1/4	1/4	1/4	1/3
Power (V-Hz-Ph)	115-60-1	115 -60-1	115-60-1	115-60-1
Temp. Range (°F)	32 - 42	32 - 42	32 - 42	32 - 42
Refrigerant	R-134A	R-134A	R-134A	R-134A
Crated Weight (LBS)	250	280	297	380
Amps (A)	4.50	4.50	4.50	4.50
Exterior Dimensions (W x D x H* inches)	49 x 24 1/2 x 37	57 3/4 x 24 1/2 x 37	68 x 24 1/2 x 37	89 1/4 x 24 1/2 x 37

Back Bar & Direct Draw Keg Refrigerators

Model	EBD2-BB	EBD2-BBG	EBD3-BB	EBD3-BBG
Capacity(Cu. Ft.)	20.09	20.09	24.01	24.01
Door(s)	2(SD)	1(SD), 1(GD)	2(SD)	1(SD), 1(GD)
Shelves	2	2	2	2
Capacity 12 oz. Cans / Bottles	280 / 192	280 / 192	360 / 240	360 / 240
Compressor (HP)	1/4	1/4	1/4	1/4
Power (V-Hz-Ph)	115-60-1	115 -60-1	115-60-1	115-60-1
Temp. Range (°F)	32 - 42	32 - 42	32 - 42	32 - 42
Refrigerant	R-134A	R-134A	R-134A	R-134A
Crated Weight (LBS)	280	297	320	337
Amps (A)	4.50	4.50	4.50	4.50
Exterior Dimensions (W x D [†] x H* inches)	57 3/4 x 27 x 37	57 3/4 x 27 x 37	68 x 27 x 37	68 x 27 x 37

[NOTE]

* Ext. height does not includes 5" for towers.
(This EBD1 model is equipped with pre-installed casters as standard feature).

† Depth does not include protruding door handle.

a Depth includes 1 1/2" for back grill.

b Height includes 5" for casters.

Specifications subject to change without notice.



24" Deep Back Bar & Direct Draw Keg Refrigerators

Model	EBDS2-BB-24	EBD2-BB-24	EBD3-BB-24
Capacity(Cu. Ft.)	13.95	16.86	20.41
Door(s)	2(SD)	2(SD)	2(SD)
Shelves	2	2	2
Capacity 12 oz. Cans / Bottles	175 / 126	245 / 168	315 / 210
Compressor (HP)	1/4	1/4	1/4
Power (V-Hz-Ph)	115-60-1	115 -60-1	115-60-1
Temp. Range (°F)	32 - 42	32 - 42	32 - 42
Refrigerant	R-134A	R-134A	R-134A
Crated Weight (LBS)	254	277	310
Amps (A)	4.50	4.50	4.50
Exterior Dimensions (W x D x H* inches)	49 x 24 1/2 x 37	57 3/4 x 24 1/2 x 37	68 x 24 1/2 x 37

Model	EBDS2-BBG-24	EBD2-BBG-24	EBD3-BBG-24
Capacity(Cu. Ft.)	13.95	16.86	20.41
Door(s)	1(SD), 1(GD)	1(SD), 1(GD)	1(SD), 1(GD)
Shelves	2	2	2
Capacity 12 oz. Cans / Bottles	175 / 126	245 / 168	315 / 210
Compressor (HP)	1/4	1/4	1/4
Power (V-Hz-Ph)	115-60-1	115 -60-1	115-60-1
Temp. Range (°F)	32 - 42	32 - 42	32 - 42
Refrigerant	R-134A	R-134A	R-134A
Crated Weight (LBS)	263	287	325
Amps (A)	4.50	4.50	4.50
Exterior Dimensions (W x D [†] x H* inches)	49 x 24 1/2 x 37	57 3/4 x 24 1/2 x 37	68 x 24 1/2 x 37

Club Top Direct Draw Keg Refrigerators

Model	EBD2-CT	EBD3-CT	EBD4-CT
Capacity(Cu. Ft.)	20.09	24.01	32.37
Door(s)	2	2	3
Shelves	1	1	1
Compressor (HP)	1/4	1/4	1/3
Power (V-Hz-Ph)	115-60-1	115 -60-1	115-60-1
Temp. Range (°F)	32 - 42	32 - 42	32 - 42
Refrigerant	R-134A	R-134A	R-134A
Crated Weight (LBS)	293	331	373
Amps (A)	4.50	4.50	4.50
Exterior Dimensions (W x D x H* inches)	57 3/4 x 27 x 37	68 x 27 x 37	89 1/4 x 27 x 37

[NOTE]

* Ext. height does not includes 5" for towers.

† Depth does not include protruding door handle.

Specifications subject to change without notice.

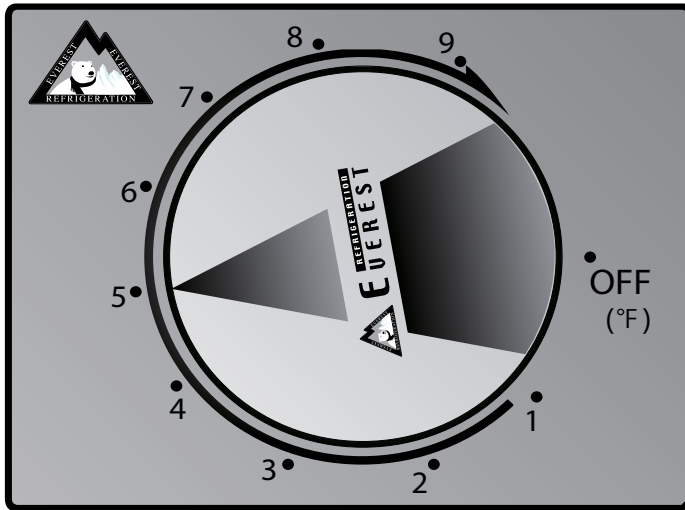

[Temperature Setting Range]

Setting Range	Comp.	REF (°F)
1 ~ 3	On	48
	Off	41
3 ~ 5	On	39
	Off	31
6 ~ 9	On	30
	Off	21

• Factory Recommended Setting: "5"

Direct Draw Keg Refrigerators

★ 3/4" O.D.

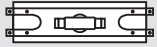

T-Shaped PVC
Drain Fittings w/
Moveable Plug

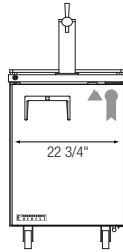

EBD1

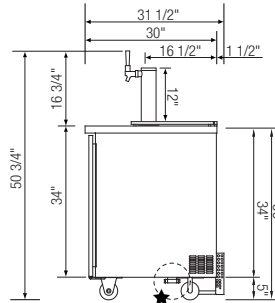

Pre-installed casters

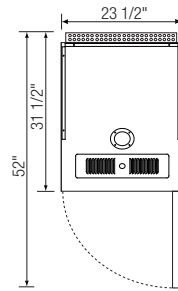

Top view

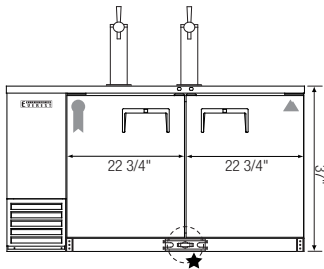

EBD2

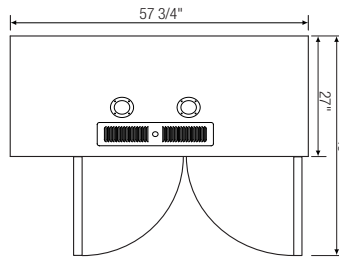

Side View

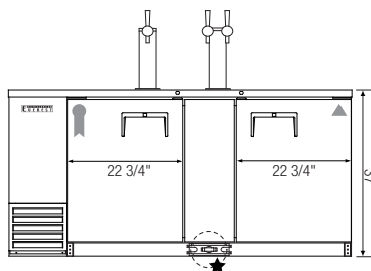
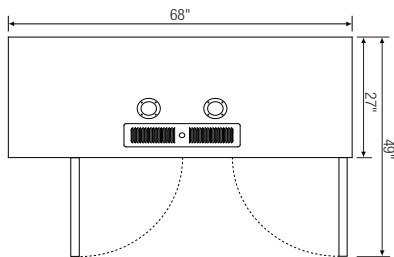

EBD3

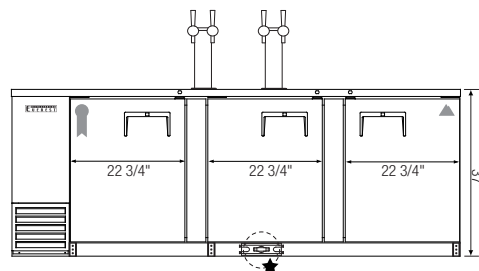
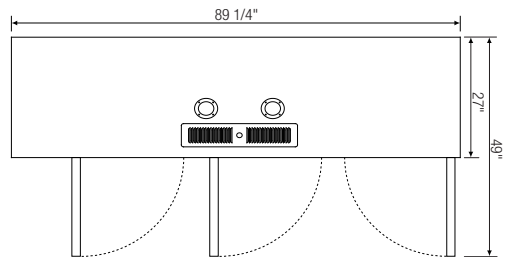

EBD4

24" Deep Direct Draw Keg Refrigerators

★ 3/4" O.D.

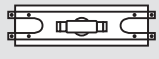

T-Shaped PVC
Drain Fittings w/
Moveable Plug

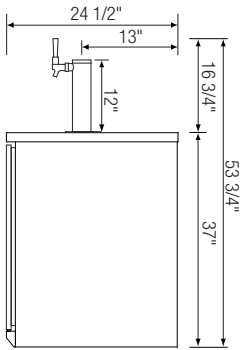

Side View

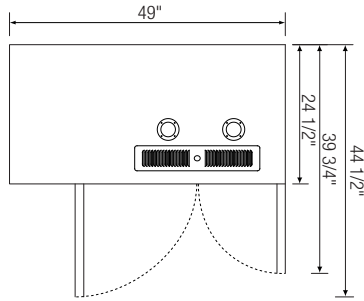

▲ EBD3-24

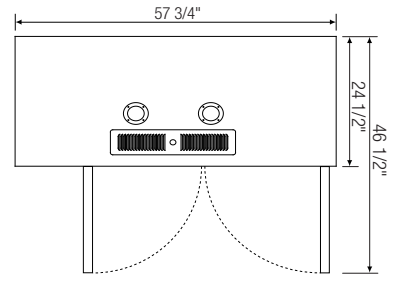

EBD2-24

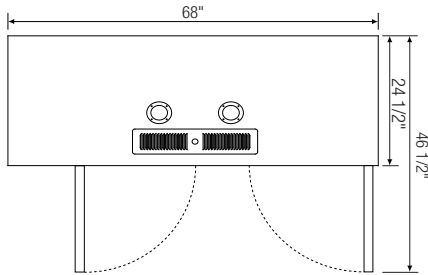
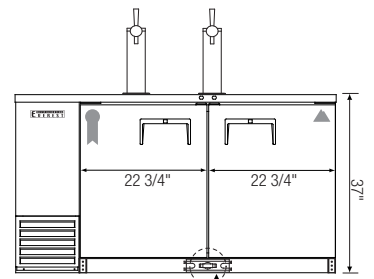
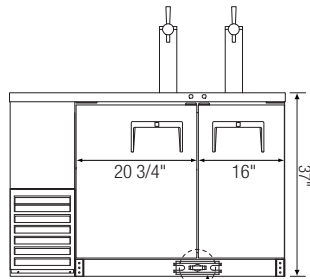

EBD3-24

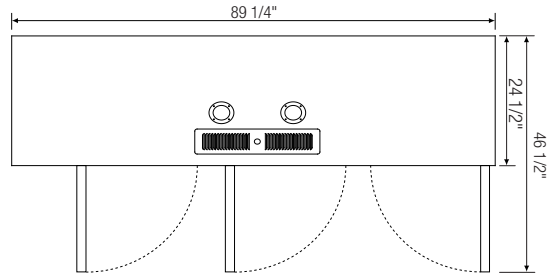

EBD4-24

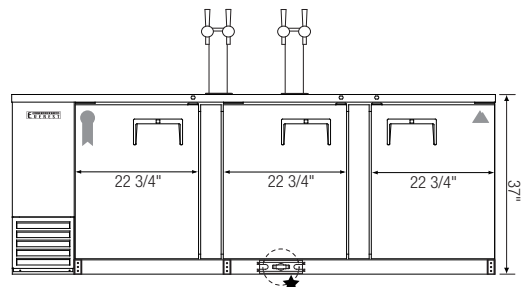
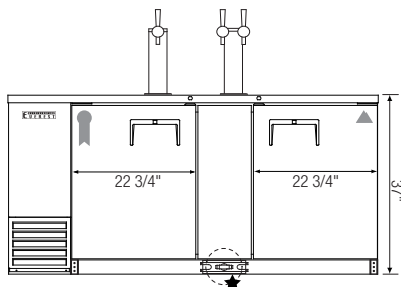

Back Bar & Direct Draw Keg Refrigerators

★ 3/4" O.D.



T-Shaped PVC
Drain Fittings w/
Moveable Plug

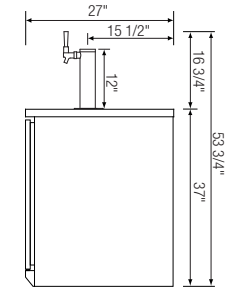

Side View
(EBD2-BB / EBD3-BB)

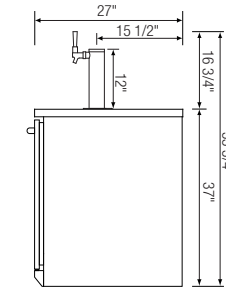

Side View
(EBD2-BBG / EBD3-BBG)

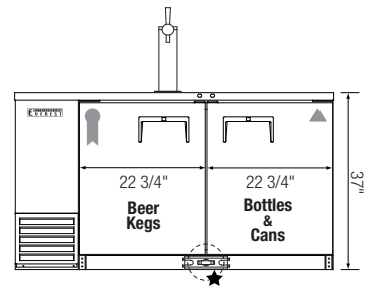

EBD2-BB

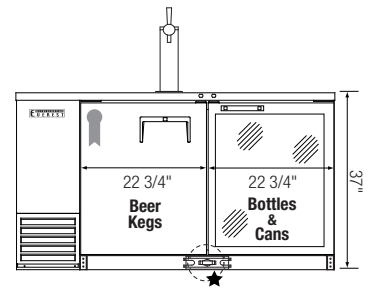
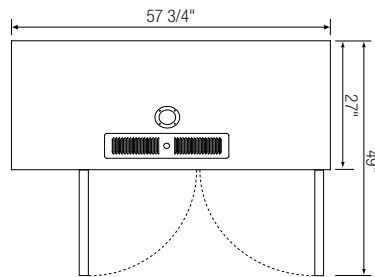

EBD2-BBG

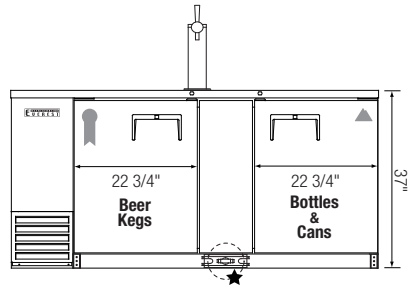
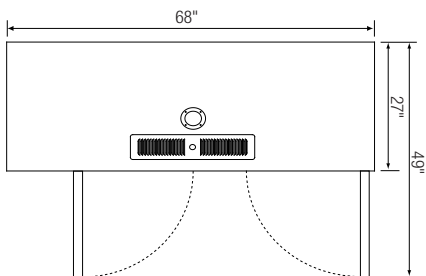

EBD3-BB

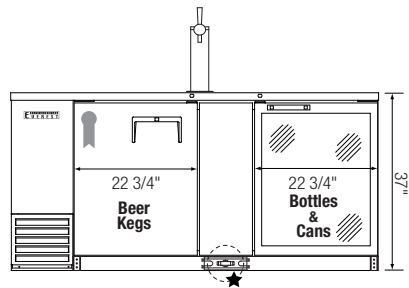
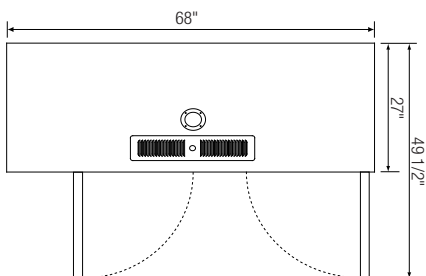

EBD3-BBG



24" Deep Back Bar & Direct Draw Keg Refrigerators

★ 3/4" O.D.

T-Shaped PVC
Drain Fittings w/
Moveable Plug

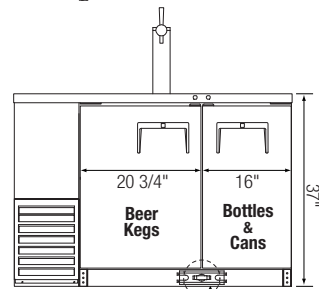
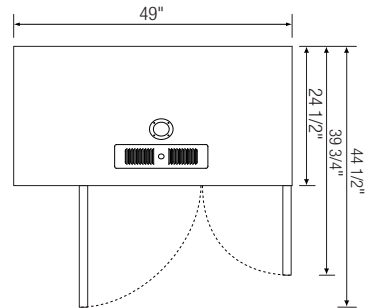
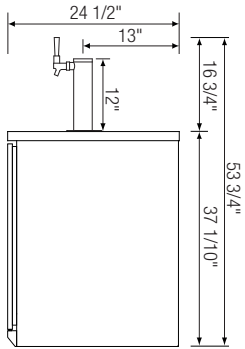

EBDS2-BB-24

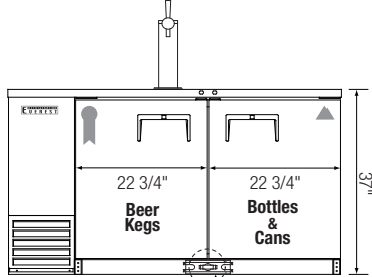
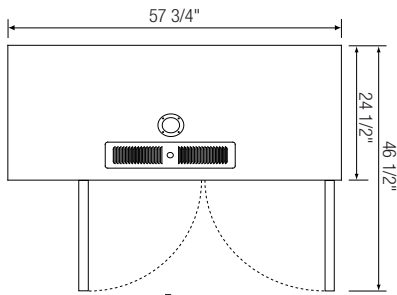

EBD2-BB-24

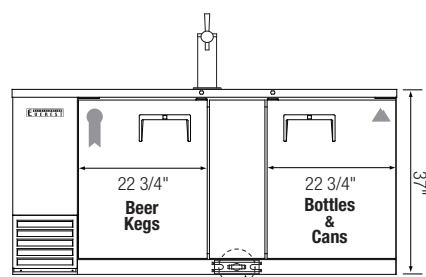
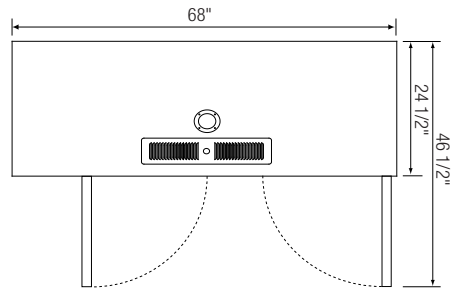

EBD3-BB-24



24" Deep Back Bar & Direct Draw Keg Refrigerators

★ 3/4" O.D.

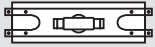

T-Shaped PVC
Drain Fittings w/
Moveable Plug

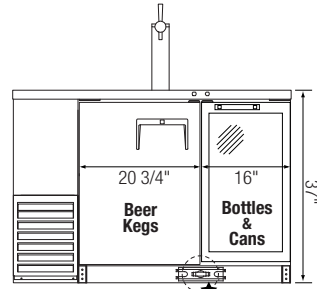
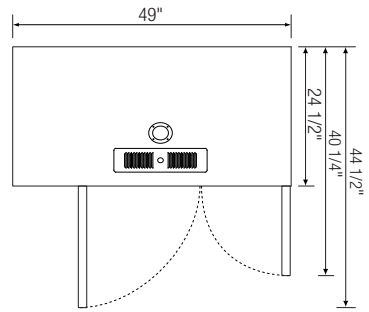
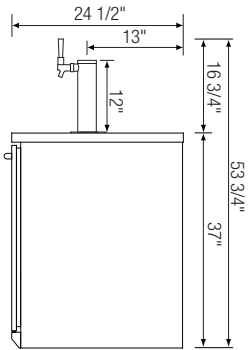

▲ EBDS2-BBG-24

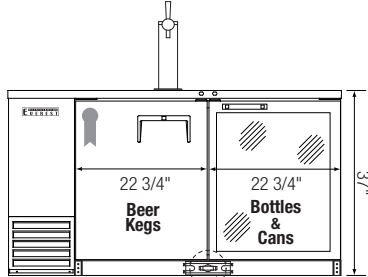
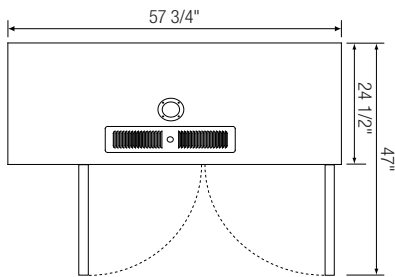

▲ EBD2-BBG-24

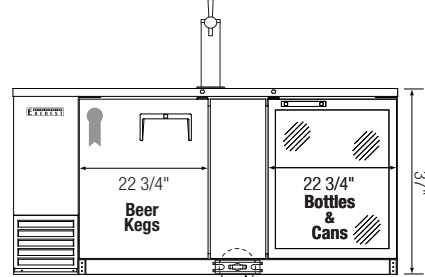
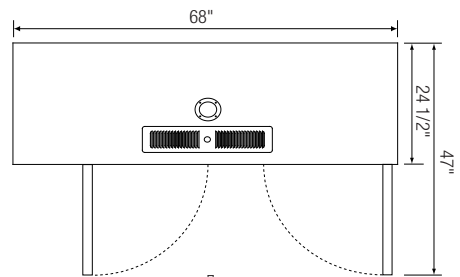

▲ EBD3-BBG-24

Club Top Direct Draw Keg Refrigerators

★ 3/4" O.D.

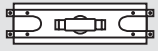

T-Shaped PVC
Drain Fittings w/
Moveable Plug

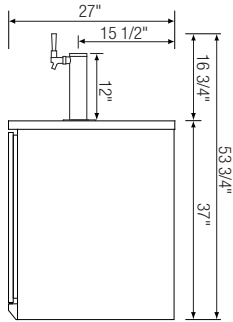

Side View

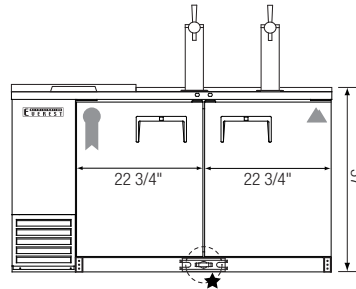
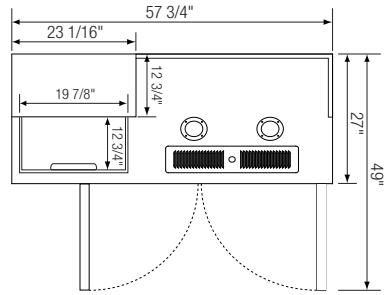

▲ EBD2-CT

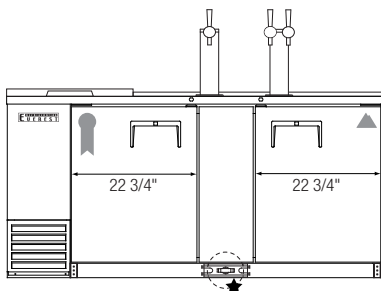
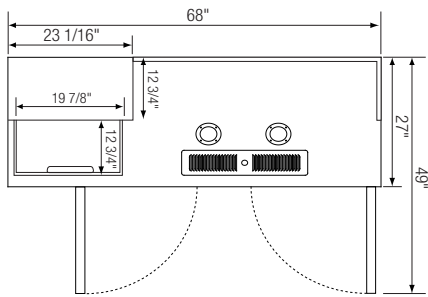

▲ EBD3-CT

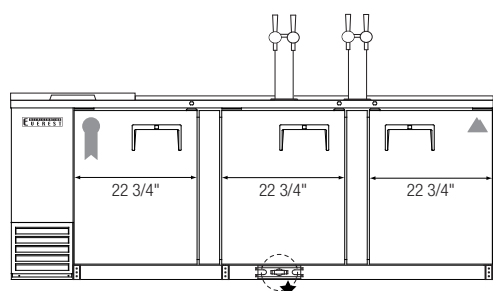
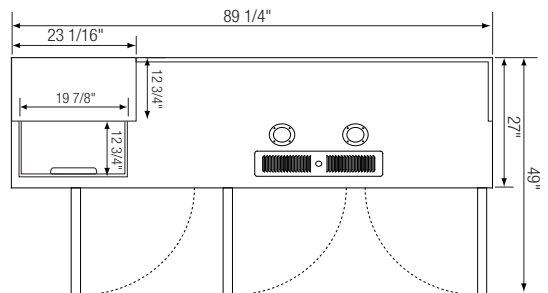

▲ EBD4-CT

Drilling Ports For CO2 Lines

Applicable Serial Numbers

BBD1-0801-XXXX ~ BBD1-1209-XXXX

BBD2-0801-XXXX ~ BBD1-1209-XXXX

BBD3-0801-XXXX ~ BBD1-1209-XXXX

BBD4-0801-XXXX ~ BBD1-1209-XXXX

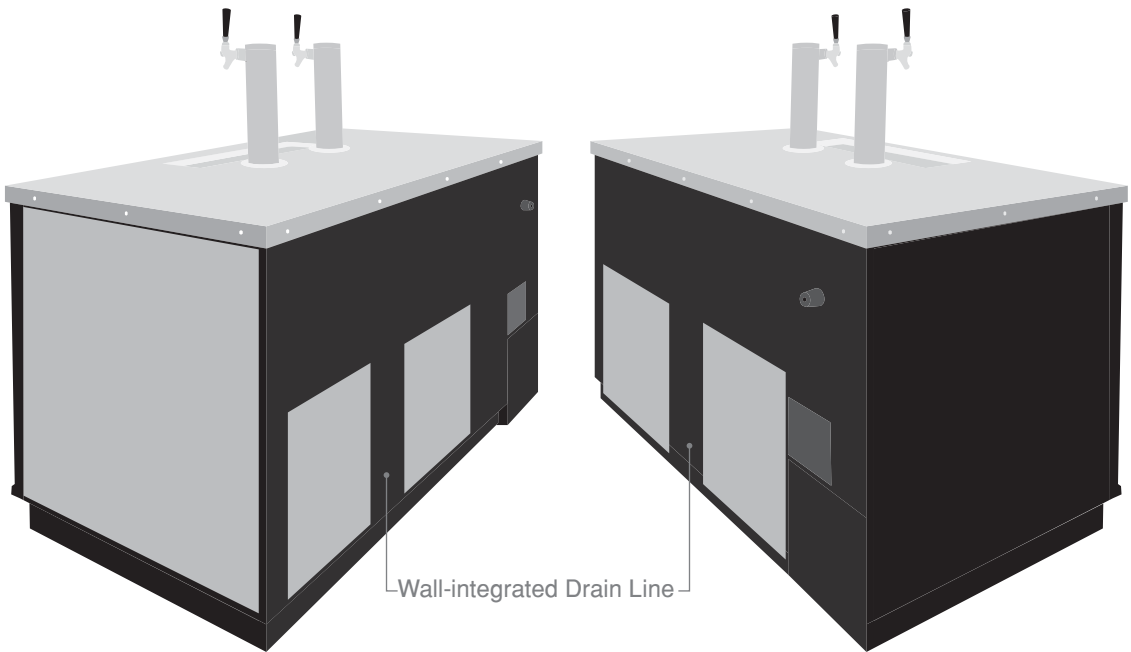

Left Back View

Right Back View

To avoid damaging refrigeration components and wiring, please drill holes for CO2 lines only in the highlighted areas.

For further assistance, please contact our **Technical Support Department at 1-800-444-6285.**

Drilling Ports For CO2 Lines

Applicable Serial Numbers

BBD1-1210-XXXX ~ Present

BBD2-1210-XXXX ~ Present

BBD3-1210-XXXX ~ Present

BBD4-1210-XXXX ~ Present

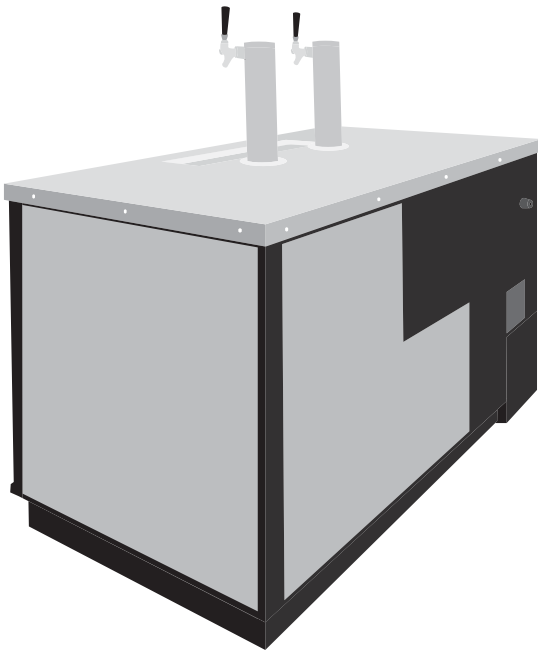

Left Back View

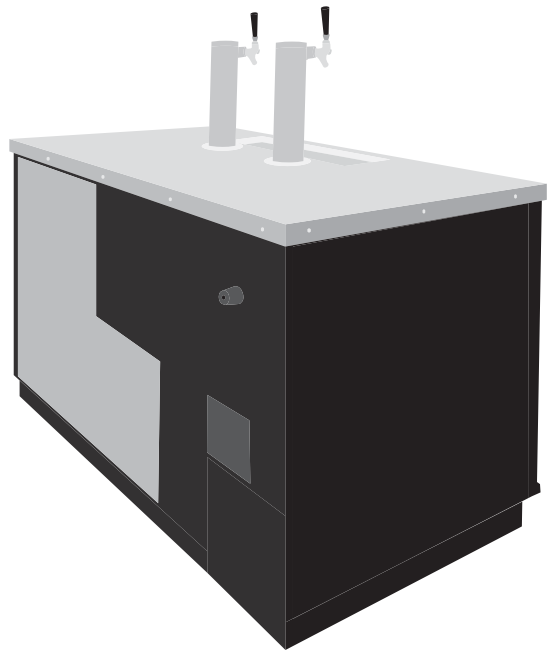

Right Back View

To avoid damaging refrigeration components and wiring, please drill holes for CO2 lines only in the highlighted areas.

For further assistance, please contact our **Technical Support Department at 1-800-444-6285.**

Installation Instructions



* Air distributor is only on multiple keg units, each keg is conneted to a valve on the air distributor.
Single keg is connected directly to the regulator.

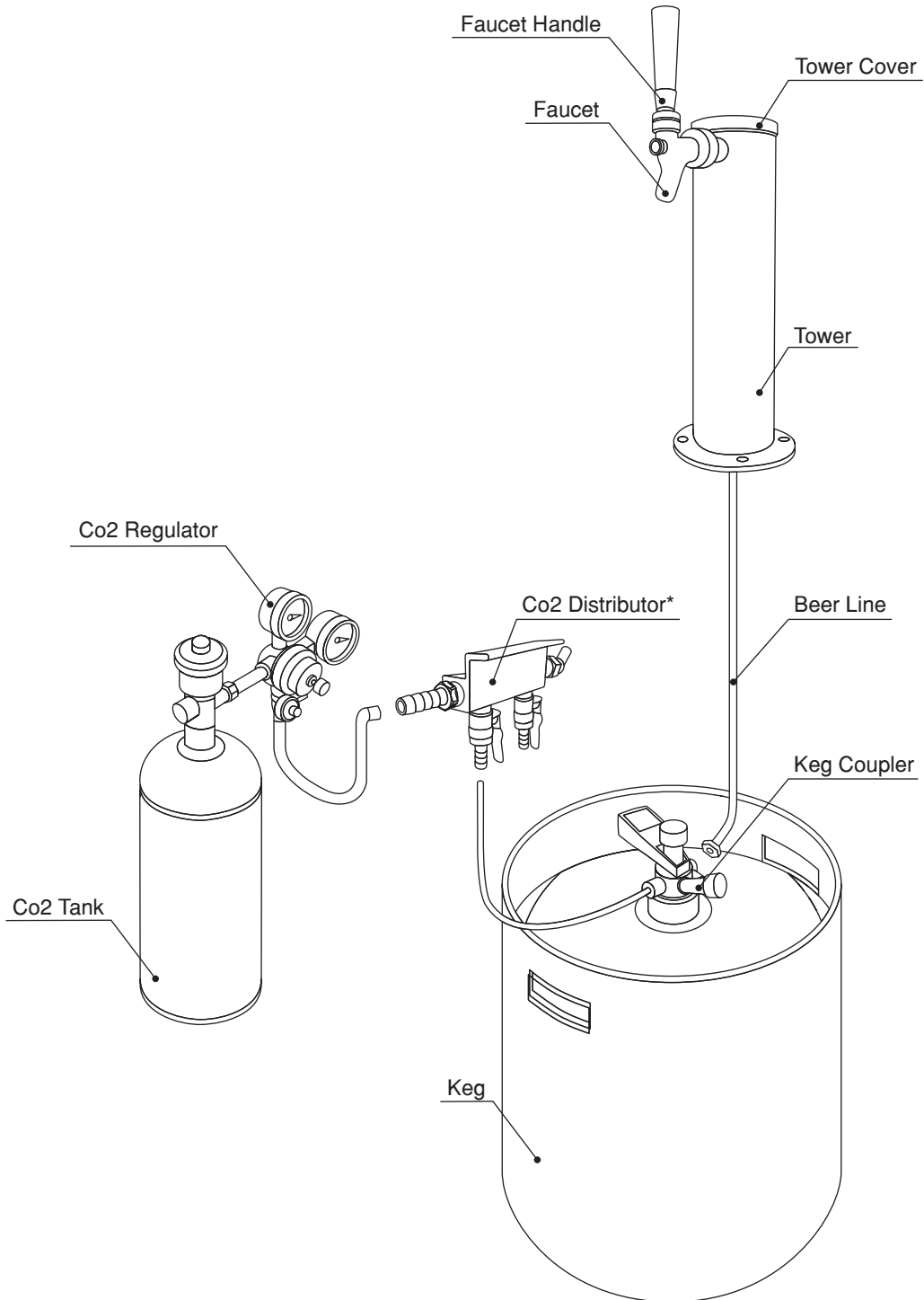

NOTE

The keg, keg coupler, CO2 regulator, CO2 tank, keg coupler to CO2 distributor line, and CO2 distributor to CO2 regulator line, are not included with your keg refrigerator. These items can be obtained from your beverage distributor. The beer tower with faucet, faucet handle, tower beer line, and CO2 distributor are included.

- 1 Position tower gasket so that the drain line and screw holes align properly with the top surface of the unit. Feed the tower's beer line through the unit's beer line hole.

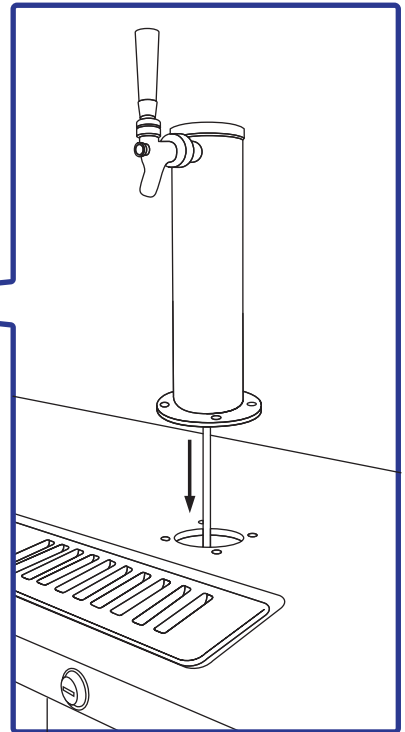
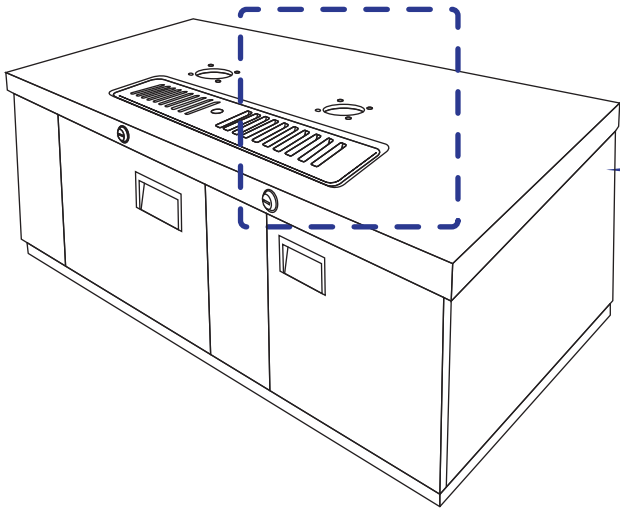

- 2 Secure the tower to the unit using the four screws provided.

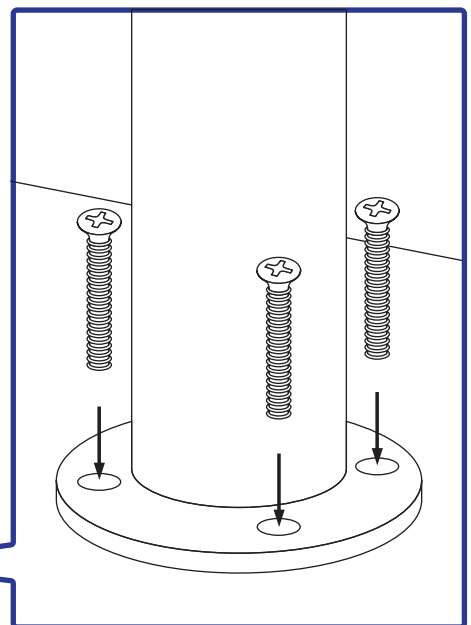
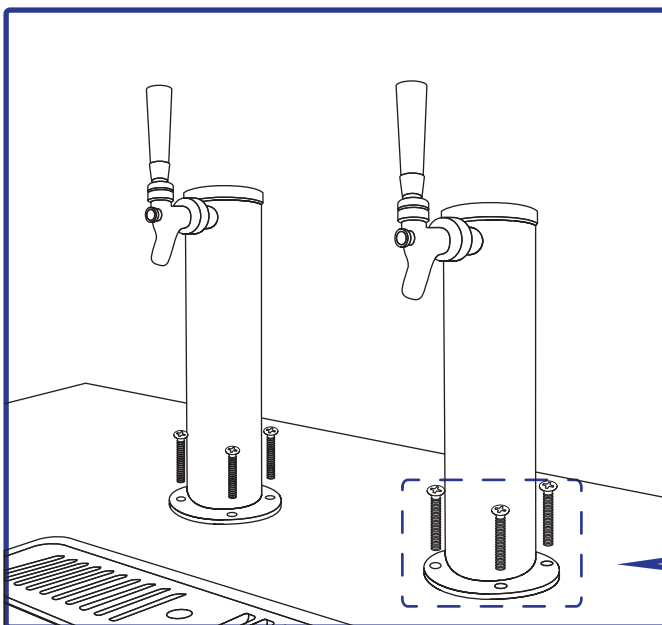

3 Insert the end of the cold air hose without a hook into the air baffle.

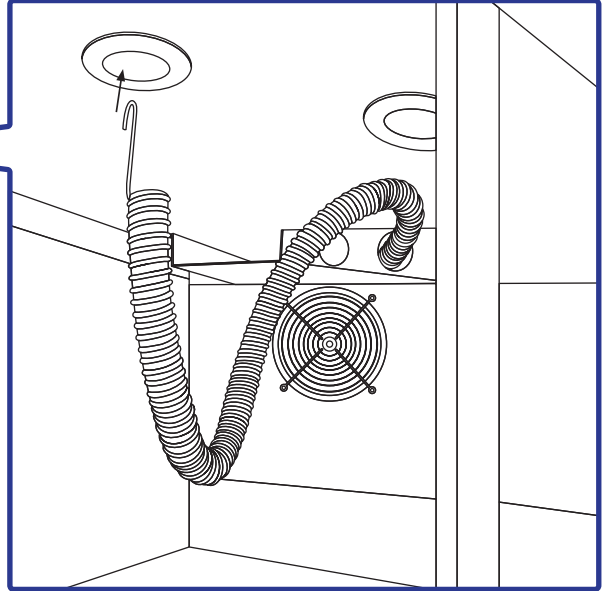
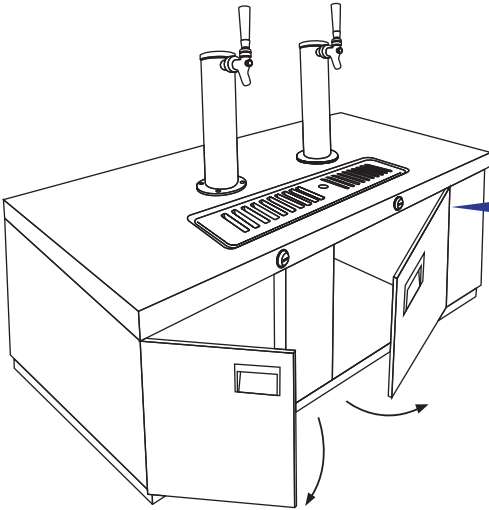

4 Remove the beer tap tower's cap.

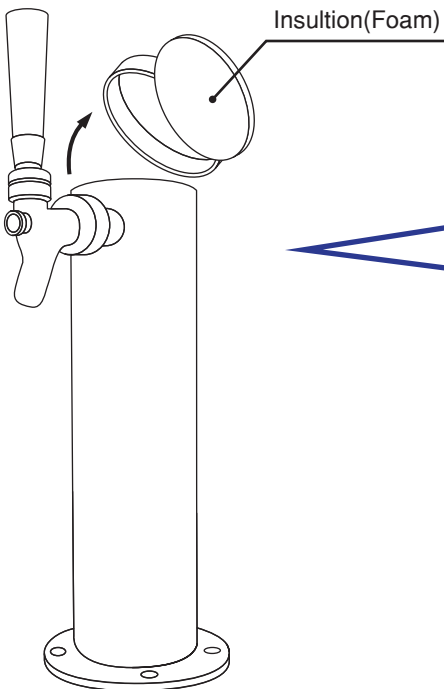

5 Feed the end of the cold air hose with a hook through the bottom of the tower and attach the hook to the beer tap retaining nut.

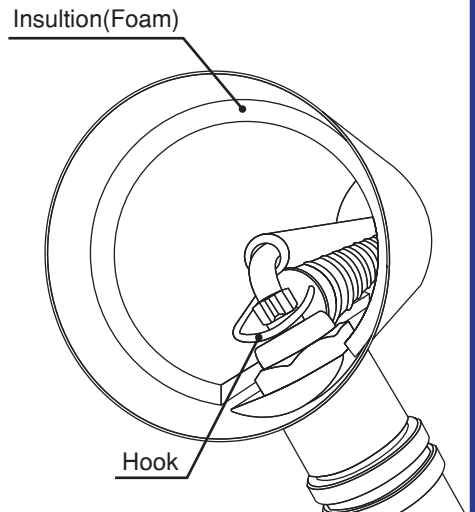



6 Replace the beer tap tower's cap.

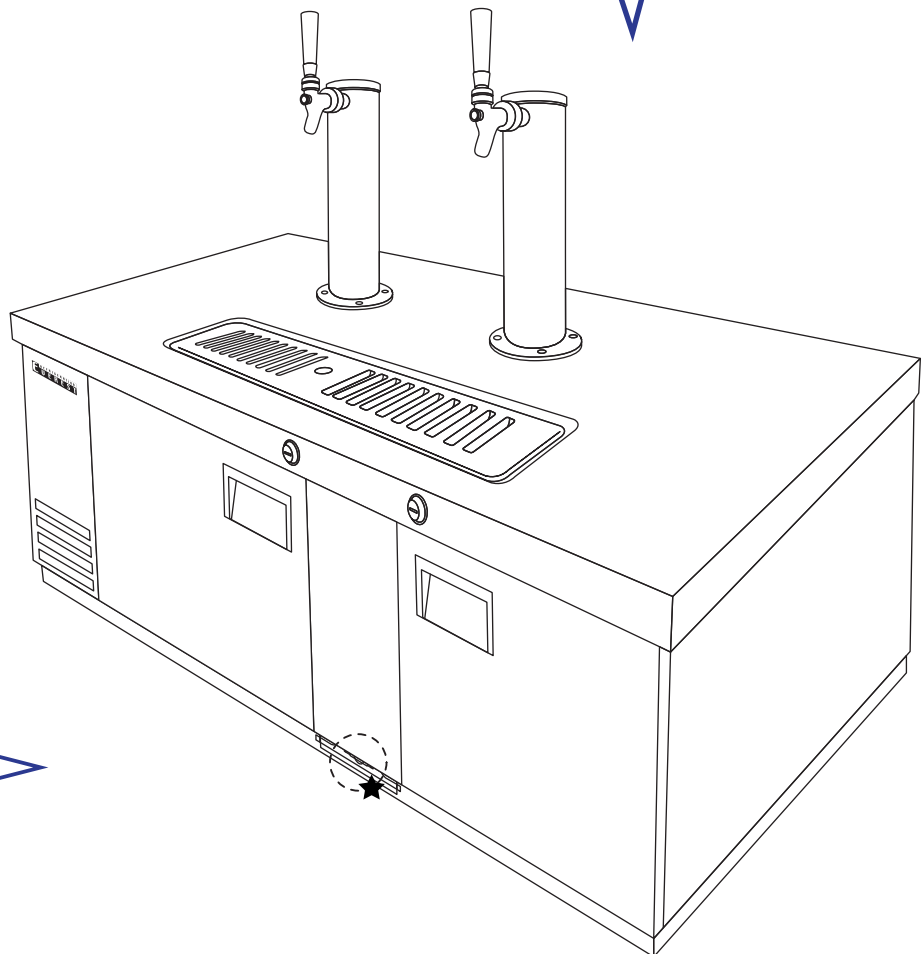
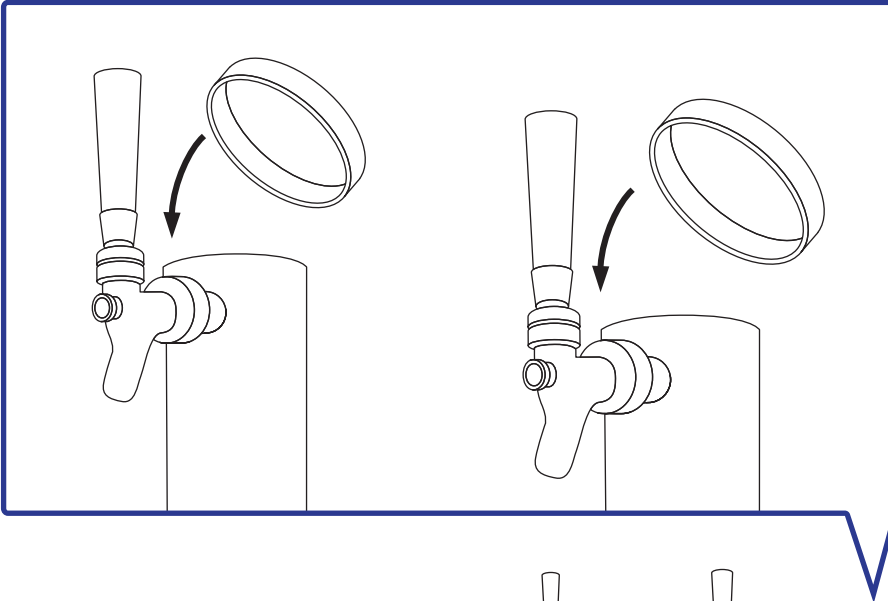

★ 3/4" O.D.



T-Shaped PVC
Drain Fittings w/
Moveable Plug



* NOTE: The CO₂ distributor can be used to share the single CO₂ tank with multiple kegs.

1. CO₂ tank placement (inside or outside of the refrigerated cabinet)

- a. Outside of Cabinet - Drill a hole on the back wall of the unit, only in the areas indicated in figure; Drilling in any other place may cause damage to the unit's wiring.
- b. Inside of Cabinet – Depending on the unit model and size of the equipped keg, you may be able to fit the CO₂ tank inside of the refrigerated cabinet; This setup requires no drilling.

2. Connect CO₂ Line to CO₂ Regulator

- a. Ensure that the CO₂ regulator's shut off valve is closed.
The switch's lever should be perpendicular to the CO₂ line when it is in the closed position.
- b. Connect one end of the CO₂ line to the CO₂ regulator's hose barb connection, pushing the hose onto the barb connector as high as you can without damaging the hose. Secure the hose to the connector using a clamp. Place the clamp as high up as possible without it interfering with the operation of the valve.
- c. If the CO₂ tank has been placed out of the refrigerated cabinet, feed the hose through the hole that was previously drilled in the back of the unit.

3. Connect CO₂ Regulator to CO₂ tank

- a. Ensure that the CO₂ tank is full and closed.
- b. Attach the CO₂ regulator to the CO₂ tank using the large nut that is part of the regulator.

4. Connect Keg Coupler

- a. **IMPORTANT:** Ensure that the keg pull handle is closed (upper position).
- b. Install the keg coupler onto the keg's locking neck and turn clockwise to lock into place.

5. Connect CO₂ Line to Keg Coupler

- a. Connect the open end of the CO₂ line to the keg coupler's hose barb connection, pushing the hose onto the barb connector as high as you can without damaging the hose. Secure the hose to the connector using a clamp. Place the clamp as high up as possible without it interfering with the operation of the valve.

6. Connect Beer Line to Keg Coupler

- a. Install the rubber washer onto the beer line hex nut fitting.
- b. Remove the plastic protective cover from the keg coupler, if equipped.
- c. Connect the beer line from the tower to the keg coupler.
It connects to the screw type connection on top of the coupler.

7. Tap Keg

- a. Pull the tap handle out and away from the keg coupler and push down until it locks into position. A click noise should be heard once the handle is in its final lock position.



* NOTE: The CO₂ distributor can be used to share the single CO₂ tank with multiple kegs.

8. Calibrating CO₂ Regulator

- a. With the shut-off valve on the CO₂ regulator closed, open the valve on the CO₂ tank completely.
- b. Loosen the adjustment nut with a pair of pliers, allowing the adjustment screw to be turned counter-clockwise until the screw can no longer turn.
- c. Slowly turn the CO₂ regulator adjustment screw until the desired pressure is shown on the output pressure gauge (12 PSI is recommended setting for most situations). Other conditions, such as altitude or special beer type, may require some adjustment. On regulators designed for draft beer, turning clockwise will increase the output pressure, and turning counter-clockwise will decrease the output pressure.
- d. Open the shut-off valve on the CO₂ regulator, ensuring the switch below the main body should be parallel to the tubing. Gas should now flow from the regulator to the keg coupler, and you will hear the keg pressurizing. The output needle will drop momentarily while the pressure is equalizing, then it will return to the point at which you set it.
- e. The keg coupler is designed with a pressure relief valve (PRV). Pull the ring on the PRV briefly to allow gas to vent. This will permit gas to flow through the regulator and help obtain a more accurate reading on the output pressure gauge.
- f. Re-check the output pressure on the regulator and, if necessary, re-adjust using step 8.3 until the desired pressure is shown. It is always wise to follow up any adjustment to the regulator with a brief pull of the PRV ring to ensure an accurate output reading.

9. Position the keg in the refrigerated compartment. Ensure that no hoses are kinked or crushed.



CONDENSER COIL MAINTENANCE

Failure to maintain a clean condenser coil will eventually result in compressor failure and product loss. Mechanical failures due to a lack of or improper maintenance are not covered under warranty. Keeping the condenser coil clean will maximize energy savings. Cleaning of the condenser coil is part of regular maintenance and is not covered under warranty.

CONDENSER COIL CLEANING PROCEDURE

Please use the following steps to clean the condenser coil. If you have any questions regarding this procedure, please call the Everest customer service department at (800) 444-6285.

1. Unplug the unit from the wall.
2. Remove the ventilation grill located at the left side or back of the unit, depending on the model. The grill is secured by Philips head screws.
3. Slide out the condensing unit enough so that the condenser coil can be cleaned. The condensing unit is on a tray which can be slid out by removing the Philips head screws securing the slide out tray to the unit.
4. Clean the condenser coil using a vacuum or brush. The fins of the condenser coil should only be cleaned and swept in the direction of the fins, which is up and down. Be careful not to bend the fins.
5. In some instances, the condenser coil may require professional cleaning due to a buildup of grease and dust. In this case, contact a local refrigeration company to take care of this for you.
6. Push the slide-out condenser tray fully home once cleaning is completed.
7. Secure the condenser tray using the Philips head screws that were removed in step 3.
8. Before securing the ventilation grill back onto the unit, be sure that all tools have been removed from the condenser area and that nothing will obstruct the motion of the condenser fan blade.
9. Replace the ventilation grill onto the back of the unit using the Philips head screws removed in step 2.

The warranty card below must be submitted to Everest within thirty (30) days of purchase.

WARRANTY REGISTRATION CARD

Business Name : _____ Telephone : () _____

Address : _____

City : _____ State : _____ Zip : _____

Place of Purchase : _____ Date Purchased : _____ Date Installed : _____

Model No : _____ Cabinet Serial No : _____

3 YEAR PARTS and LABOR WARRANTY

(Applicable to units purchased after July 1, 2014.)

5 YEAR COMPRESSOR WARRANTY

Name of Business Owner : _____ Date : _____

Signature of Business Owner : _____



EVEREST LIMITED WARRANTY

EVEREST warrants to the original purchaser of every new EVEREST unit, the cabinet and all parts thereof, to be free from defects in material or workmanship, under normal and proper use and maintenance service as specified by EVEREST and upon proper installation and start-up in accordance with the instruction packet supplied with each unit. Our obligation under this warranty is limited to a period of three (3) years from the date of original installation or thirty six (36) months after shipment date from EVEREST, which ever occurs first. This is applicable to units purchased after July 1, 2014. Any part covered under this warranty that is determined by EVEREST to have been defective within three (3) years of original installation or thirty six (36) months after shipment date from the manufacturer, which ever occurs first, is limited to the repair or replacement, including labor charges, of defective parts or assemblies. The labor warranty shall include standard straight time labor charges only and reasonable travel time, as determined by EVEREST.

WARRANTY CLAIMS

All warranty claims for labor or parts must be made directly through EVEREST. All claims shall include: unit model number, cabinet serial number, proof of new product purchase, installation date, and all pertinent information related to the alleged defect. For compressor warranty claims, the compressor tag shall be returned to EVEREST with the above listed information.

WARRANTY EXCLUSIONS

EVEREST's sole obligation under this warranty is limited to either the repair or replacement of parts, subject to the additional limitations below. This warranty neither assumes nor authorizes any person to assume obligations other than those expressly covered by this warranty.

A. NON WARRANTY PARTS

EVEREST excludes specific parts exposed to normal wear and tear. These parts include, but are not limited to, lamps, gaskets, casters, shelves and shelf clips, pans, bin and pan dividers and airflow guards.

B. INDIRECT OR CONSEQUENTIAL DAMAGE

EVEREST does not warrant economic loss, profit loss, or special, indirect or consequential damages including without limitation, losses or damages arising from food or product spoilage claims caused by refrigeration failure.

C. IMPROPER USAGE

EVEREST is not responsible for parts or labor coverage for component failure and or other damages resulting from improper usage, installation or failure to clean and/or maintain product as set forth in the user's manual provided with this unit. All EVEREST products are designed for commercial usage, not for residential use. Therefore, the warranty will not be honored if product is installed in a residential house.

D. WARRANTY IS NOT TRANSFERABLE

Warranty is limited to only the original purchaser/user to whom delivered. It is not transferable.

E. ALTERATION, NEGLIGENCE, MISUSE, ABUSE, ACCIDENT, DAMAGE DURING TRANSIT OR INSTALLATION, FIRE, FLOOD, ACTS OF GOD.

EVEREST is not responsible for malfunctions due to alteration, neglect, misuse, abuse, accident, damage during transit or installation, fire, flood, storm, and/or other acts of God. And EVEREST is not responsible for any improper electrical connections resulting from electrical power failure, the use of extension cords, and low voltage or voltage drops to the unit.

F. UNAUTHORIZED MODIFICATION

EVEREST is not responsible for the repair or replacement of failed or damaged components resulting from unauthorized modifications to units or the use of non-standard parts without prior written approval from EVEREST.

G. RESIDENTIAL, NON-COMMERCIAL USE

This warranty does not apply to a unit installed in a residential setting. This unit is for commercial use only.

H. OUTSIDE THE U.S.

This warranty does not apply to any parts and/or labor warranty claims made on units sold or used outside of the United States.

ADDITIONAL TWO(2) YEAR COMPRESSOR WARRANTY

In addition to the warranty set forth above, EVEREST warrants the hermetically sealed compressor for an additional two (2) years, not to exceed sixty (60) months from the date of shipment from EVEREST, provided upon receipt of the compressor, manufacturer examination shows the sealed compressor to be defective. This compressor warranty does not apply to shipping or labor costs or any other parts of the unit whether electrical or mechanical.

These warranties are exclusive and in lieu of all other warranties, expressed or implied, and all other obligations or liabilities on our part, and we neither assume nor authorize any other person to assume for us any other obligation or liability in connection with the sale of said refrigeration units or any part thereof.



EVEREST REFRIGERATION



A Step Above the Standard

201 W. Artesia Blvd., Compton CA 90220

Tel : 310-323-6586, 800-444-6285

Fax : 310-323-7524, 310-761-1127

Visit our website at www.EVERESTref.com